

DESPIECES

MESAS MFP-B

GASTRO



Rev.: Dic-2010

RECAMBIOS MESAS MFP-B-GN DIC-2010		 FAGOR FAGOFRI S.A.		MODELOS										
Nº	CÓDIGO	DESCRIPCIÓN	MFP-135-B/GN	MFP-180-B/GN	MFP-225-B/GN	MFP-270-B/GN	MFP-135-BP/GN	MFP-180-BP/GN	MFP-225-BP/GN	MFP-270-BP/GN	MFP-135-B2/GN	MFP-180-B2/GN	MFP-225-B2/GN	MFP-270-B2/GN
61	6021390006	MANG 3X1X2500 BL. SCHUKO 3T	1	1	1	1	1	1	1	1	1	1	1	1
62	M109050033	PROT SONDA 175x49	1	1	1	1	1	1	1	1	1	1	1	1
70	6021010037	CONDEN.ARRANQUE FR-117U5015 80 mF	1	1			1	1			1	1		
70	6021010158	CONDENSADOR COMP. NEK 6210Z			1	1			1	1			1	1
71	6021010045	RELE ARRANQ COMPR.FR-7.5G 6001	1				1				1			
71	6021010025	RELE ARRANQUE COMPRESOR FR-8,5G 2		1				1				1		
71	6021010156	RELE ARRAN. COMP. NEK 6210Z			1	1			1	1			1	1
90	M169010119	PUE MEP-100,MFP-B IZDA.FAGOR					2	3	4	5				
91	6045010152	BURLETE CAJON MFP2/3 Y MEP-100					2	3	4	5				
92	6003010136	CAJA ALOJAMIENTO MUELLE GRIS					2	3	4	5				
93	6033010100	BIS.TRSD DOBL MUELLE DV-2608					2	3	4	5				
94	6033010129	SOP.BISAG.INF.IZD.					2	3	4	5				
95	6033090104	EJE ROSCA EXT.30X10INOX MESAS					2	3	4	5				
96	6025130045	TUERC.RAPIDA TRT M6-2					2	3	4	5	1	1	1	1
100	M169120120	CAJÓN MFP 1/3									2	4	6	8
101	M109050102	CAJON GASTRO 2º CASO 100 prof.									2	4	6	8
102	M169120121	FRENTE CAJÓN MFP 1/3									2	4	6	8
103	6045010151	BURLET CAJON MFP1/3 399x158 07									2	4	6	8
104	M161130006	FRONTI POSTIZO MFP CAJ MAGNETI									1	2	3	4

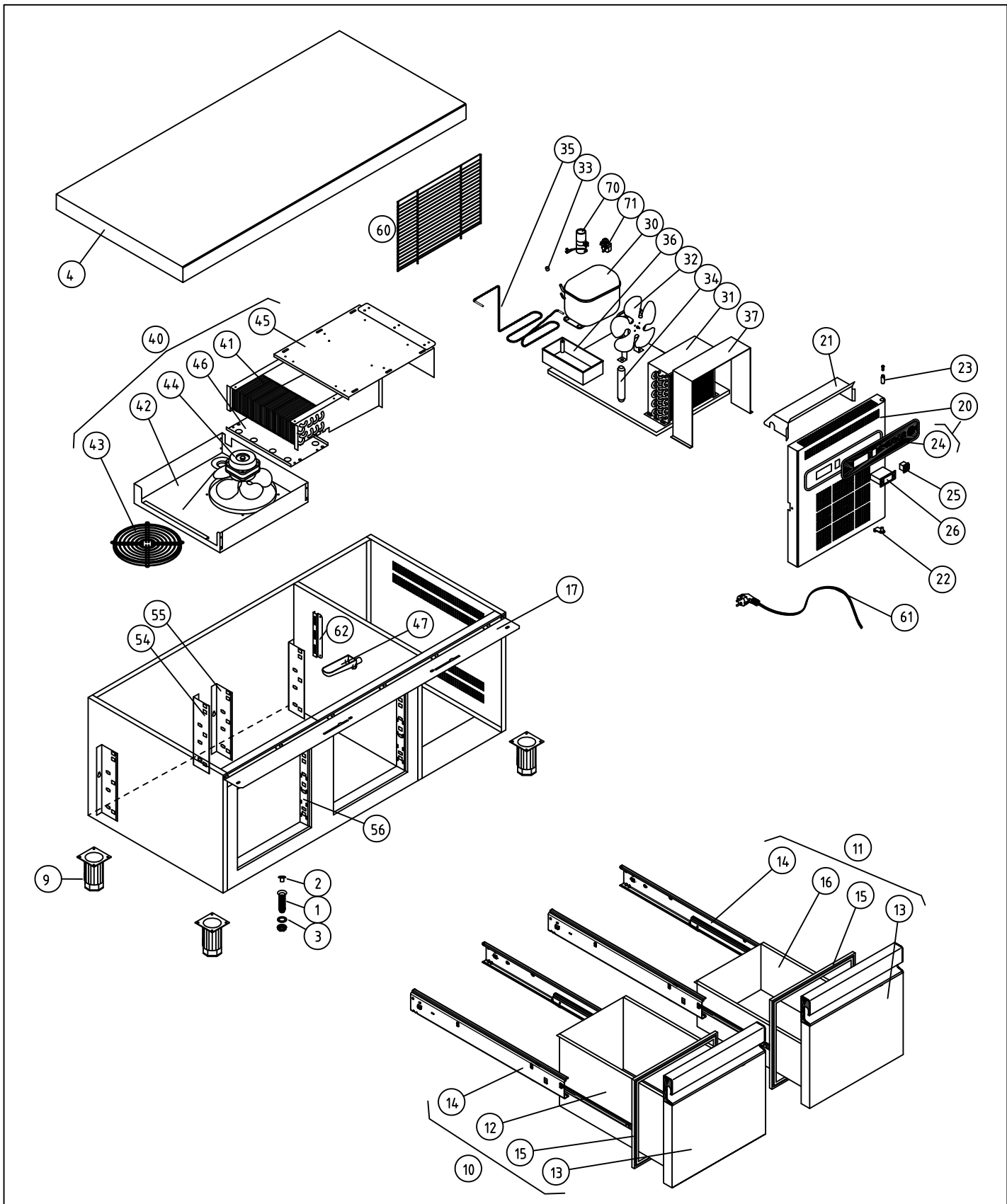

COTAS SIN TOLERANCIA DIN 7168-f						Material: MATERIAL ESPESOR				COD. PIEZA:					
GRADO TOLERANCIA						Acabado: ACABADO				SUSTITUYE A:					
ANGULAR	HASTA 10 mm	FINO	MEDIO	GRUESO		COMUN A		MODELO	Ud.	MODELO	Ud.	MODELO	Ud.	MODELO	Ud.
	MAS DE 10 A 50 mm		±1°	±1° 30'		MFP-135 B	1								
	MAS DE 50 A 120 mm		±30'	±50'											
	MAS DE 120 A 400 mm		±20'	±25'											
	MAS DE 400 mm		±10'	±15'											
			±5'	±10'											
LINEAL	GRADO TOLERANCIA	FINO	MEDIO	GRUESO	A4	Nombre		Fecha							
	HASTA 3 mm	±0,05	±0,10	±0,15	Dibujado	A.J.GONZALEZ		Dic-2010							
	MAS DE 3 A 6 mm	±0,05	±0,10	±0,20	Modificado										
	MAS DE 6 A 30 mm	±0,10	±0,20	±0,50	Escala	1:22									
	MAS DE 30 A 120 mm	±0,15	±0,30	±0,80	RECAMBIOS MFP-135-B		Código máquina:								
MAS DE 120 A 400 mm	±0,20	±0,50	±1,20			CODIGO									
MAS DE 400 A 1000 mm	±0,30	±0,80	±2,00												
MAS DE 1000 A 2000 mm	±0,50	±1,20	±3,00												

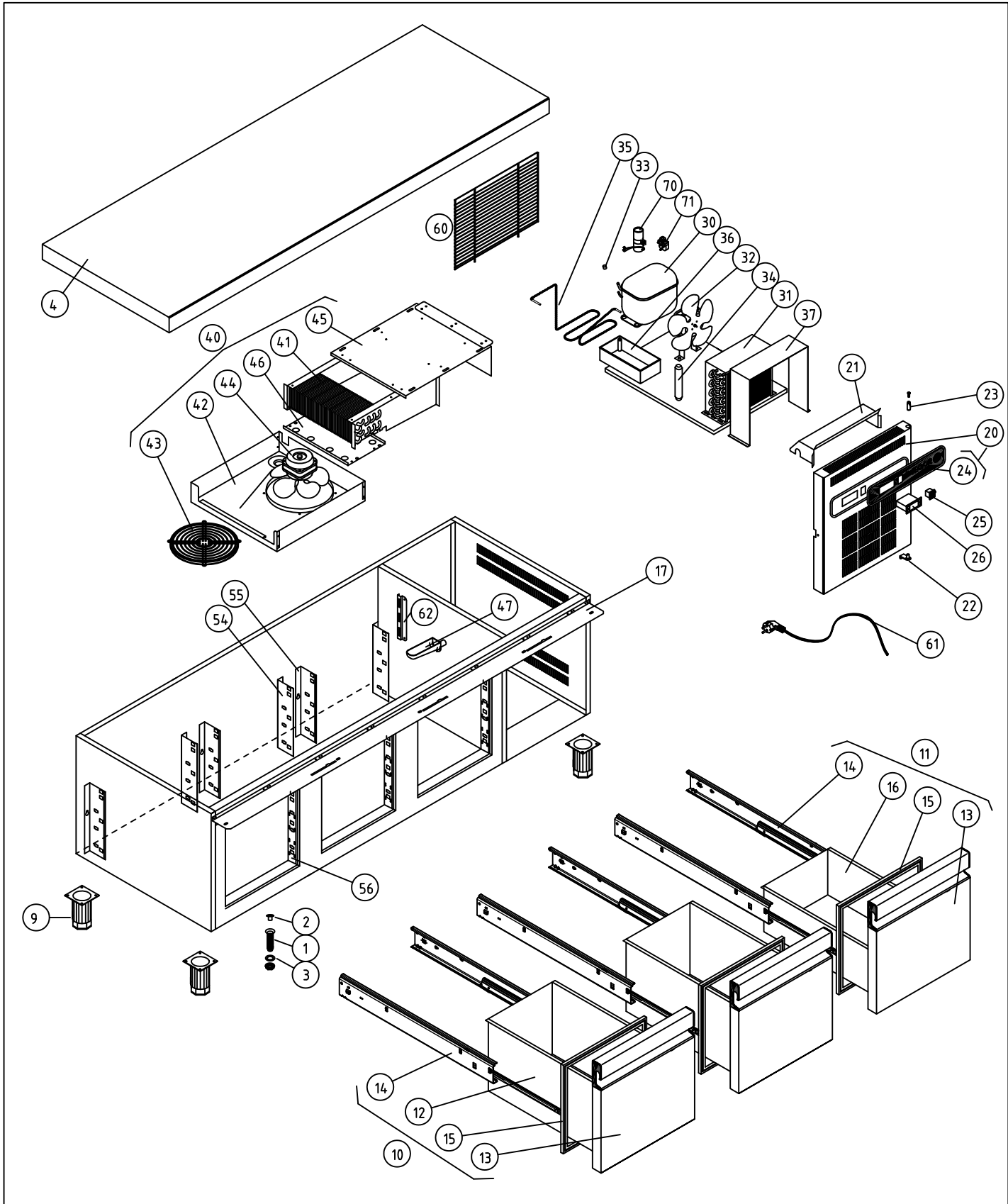

COD. PIEZA: 148315000000

COTAS SIN TOLERANCIA DIN 7168-f				Material: MATERIAL ESPESOR				SUSTITUYE A:							
				Acabado: ACABADO				SUSTITUIDO POR:							
ANGULAR	GRADO TOLERANCIA	FINO	MEDIO	GRUESO	COMUN A	MODELO	Ud.	MODELO	Ud.	MODELO	Ud.	MODELO	Ud.	MODELO	
	HASTA 10 mm		±1°	±1° 30'		MFP-180 B	1								
	MAS DE 10 A 50 mm		±30'	±50'											
	MAS DE 50 A 120 mm		±20'	±25'											
LINEAL	MAS DE 120 A 400 mm		±10'	±15'											
	MAS DE 400 mm		±5'	±10'											
	GRADO TOLERANCIA	FINO	MEDIO	GRUESO	A4	Nombre	Fecha		 FAGOR FRI						
	HASTA 3 mm	±0,05	±0,10	±0,15	Dibujado	A.J.GONZALEZ	Dic-2010								
	MAS DE 3 A 6 mm	±0,05	±0,10	±0,20	Modificado										
MAS DE 6 A 30 mm	±0,10	±0,20	±0,50	Escala	1:22		RECAMBIOS MFP-180-B								
MAS DE 30 A 120 mm	±0,15	±0,30	±0,80			Código máquina: CODIGO									
MAS DE 120 A 400 mm	±0,20	±0,50	±1,20												
MAS DE 400 A 1000 mm	±0,30	±0,80	±2,00												
MAS DE 1000 A 2000 mm	±0,50	±1,20	±3,00												

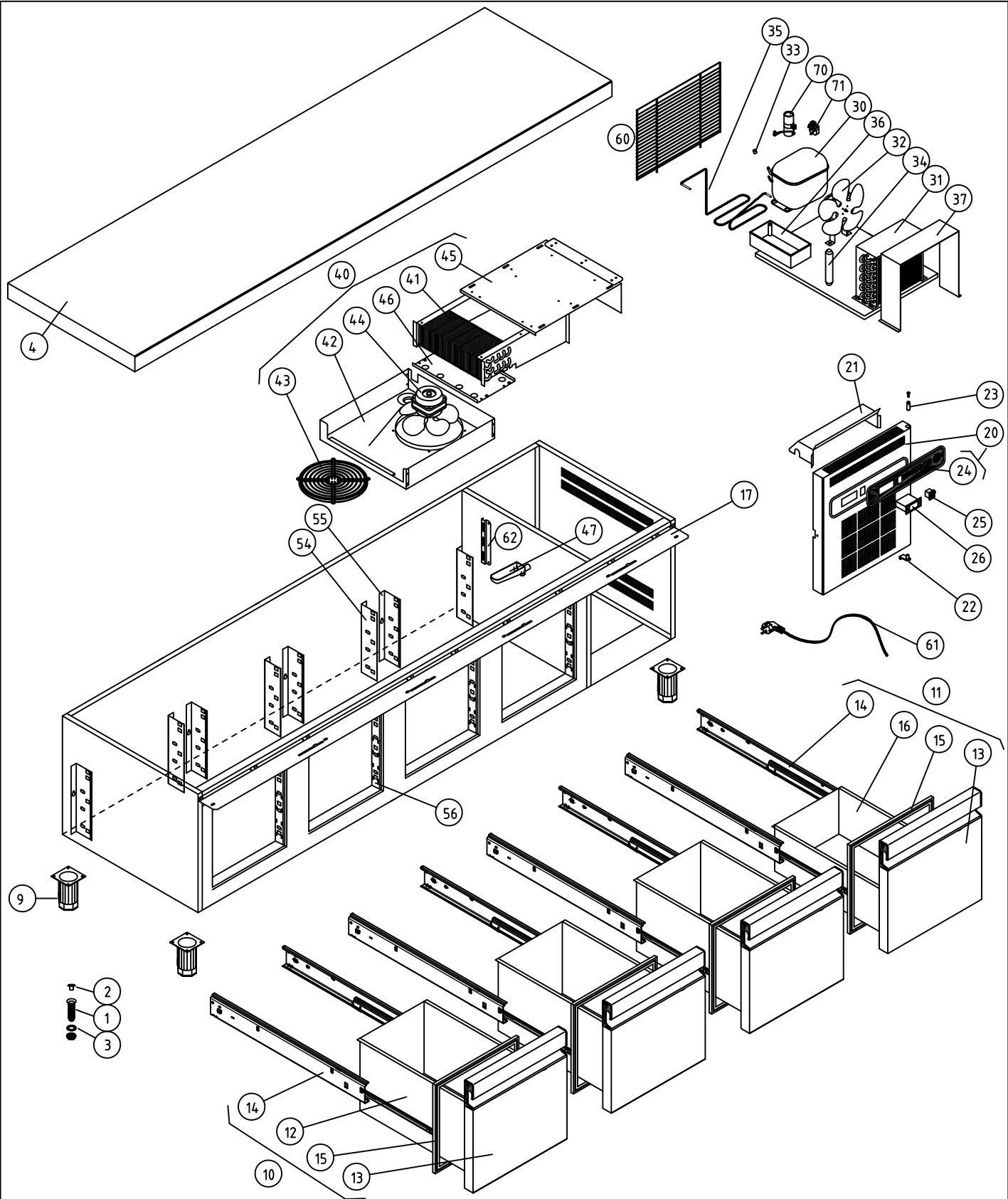

COD. PIEZA: 148316000000

COTAS SIN TOLERANCIA DIN 7168-f

GRADO TOLERANCIA	FINO	MEDIO	GRUESO
	HASTA 10 mm	±1°	
MAS DE 10 A 50 mm	±30'		±50'
MAS DE 50 A 120 mm	±20'		±25'
MAS DE 120 A 400 mm	±10'		±15'
MAS DE 400 mm	±5'		±10'

Material: MATERIAL ESPESOR

Acabado: ACABADO

COMUN A	MODELO	Ud.	MODELO	Ud.	MODELO	Ud.	MODELO	Ud.	MODELO
		MFP-225 B	1						

GRADO TOLERANCIA	FINO	MEDIO	GRUESO
	HASTA 3 mm	±0,05	±0,10
MAS DE 3 A 6 mm	±0,05	±0,10	±0,20
MAS DE 6 A 30 mm	±0,10	±0,20	±0,50
MAS DE 30 A 120 mm	±0,15	±0,30	±0,80
MAS DE 120 A 400 mm	±0,20	±0,50	±1,20
MAS DE 400 A 1000 mm	±0,30	±0,80	±2,00
MAS DE 1000 A 2000 mm	±0,50	±1,20	±3,00

A4	Nombre	Fecha
Dibujado	A.J.GONZALEZ	Dic-2010
Modificado		

Escala	1:22
--------	------



RECAMBIOS MFP-225-B

Código máquina:
CODIGO

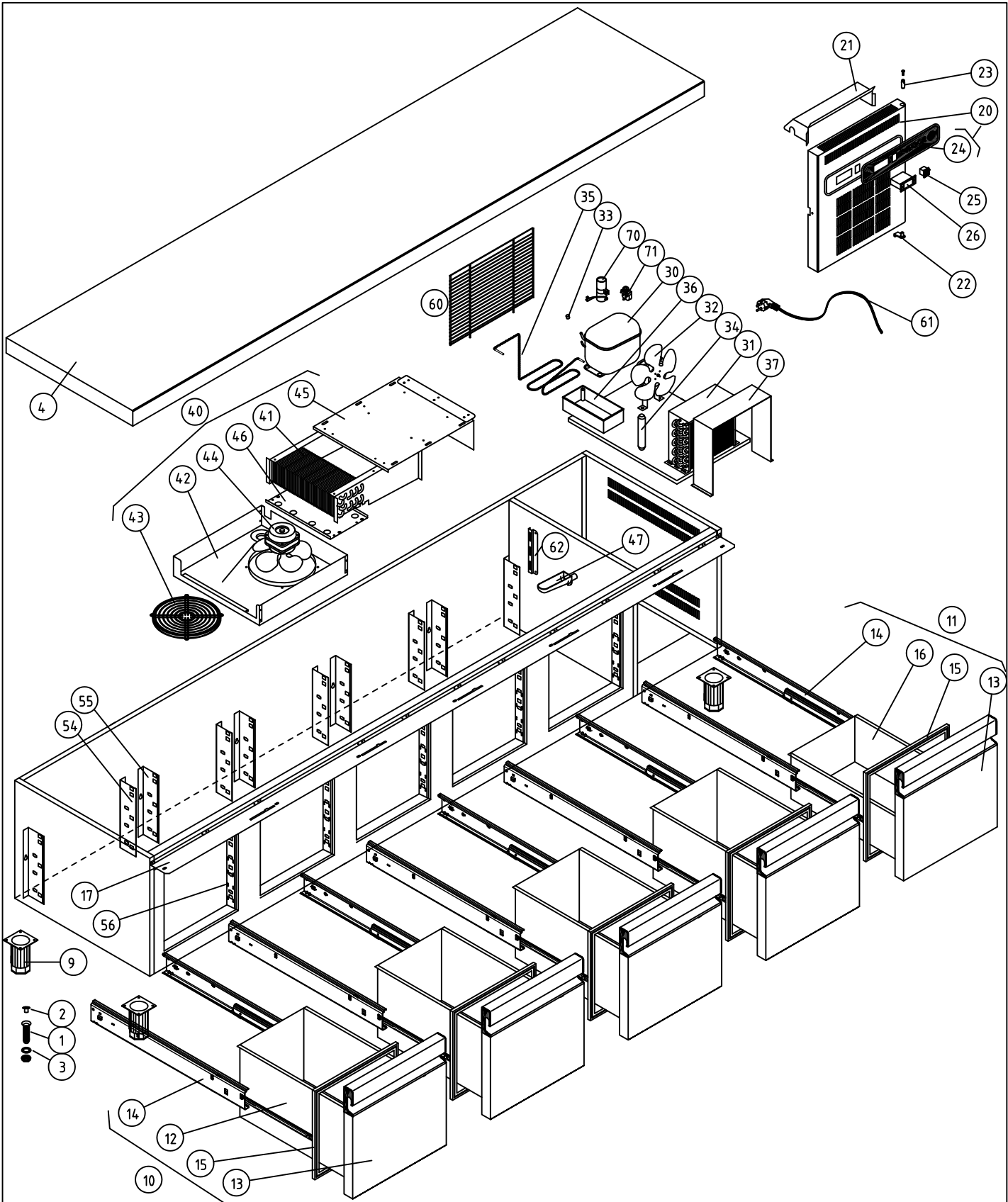

COD. PIEZA: 148318000000

COTAS SIN TOLERANCIA DIN 7168-f				Material: MATERIAL ESPESOR				SUSTITUYE A:					
				Acabado: ACABADO				SUSTITUIDO POR:					
ANGULAR	GRADO TOLERANCIA	FINO	MEDIO	GRUESO	COMUN A	MODELO	Ud.	MODELO	Ud.	MODELO	Ud.	MODELO	Ud.
	HASTA 10 mm		±1°	±1° 30'		MFP-270 B	1						
	MAS DE 10 A 50 mm		±30'	±50'									
	MAS DE 50 A 120 mm		±20'	±25'									
	MAS DE 120 A 400 mm		±10'	±15'									
	MAS DE 400 mm		±5'	±10'									
LINEAL	GRADO TOLERANCIA	FINO	MEDIO	GRUESO	A4	Nombre		Fecha					
	HASTA 3 mm	±0,05	±0,10	±0,15	Dibujado	A.J.GONZALEZ		Dic-2010					
	MAS DE 3 A 6 mm	±0,05	±0,10	±0,20	Modificado								
	MAS DE 6 A 30 mm	±0,10	±0,20	±0,50	Escala								
	MAS DE 30 A 120 mm	±0,15	±0,30	±0,80	1:22								
MAS DE 120 A 400 mm	±0,20	±0,50	±1,20							Código máquina:			
MAS DE 400 A 1000 mm	±0,30	±0,80	±2,00							CODIGO			
MAS DE 1000 A 2000 mm	±0,50	±1,20	±3,00							RECAMBIOS MFP-270-B			

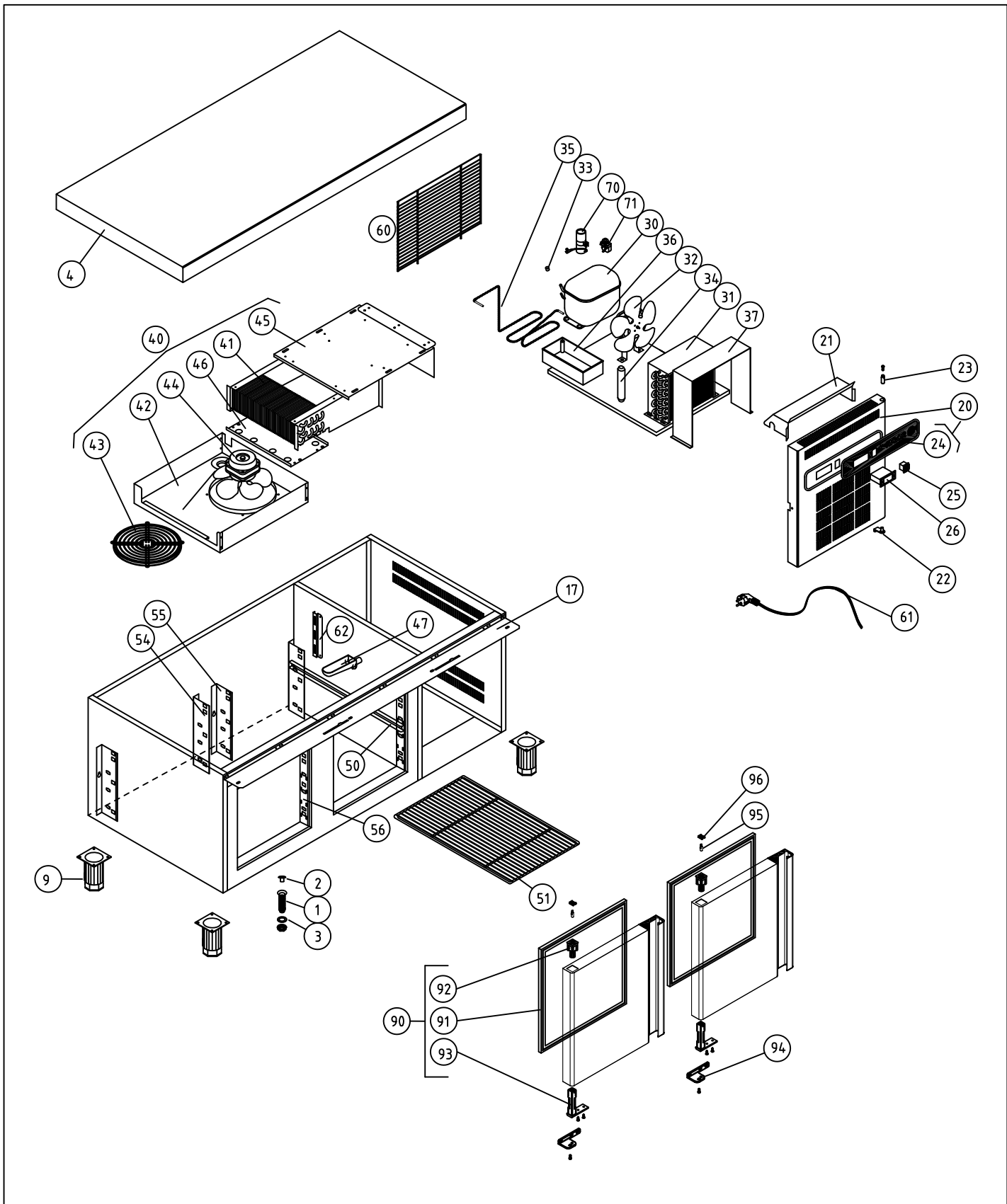

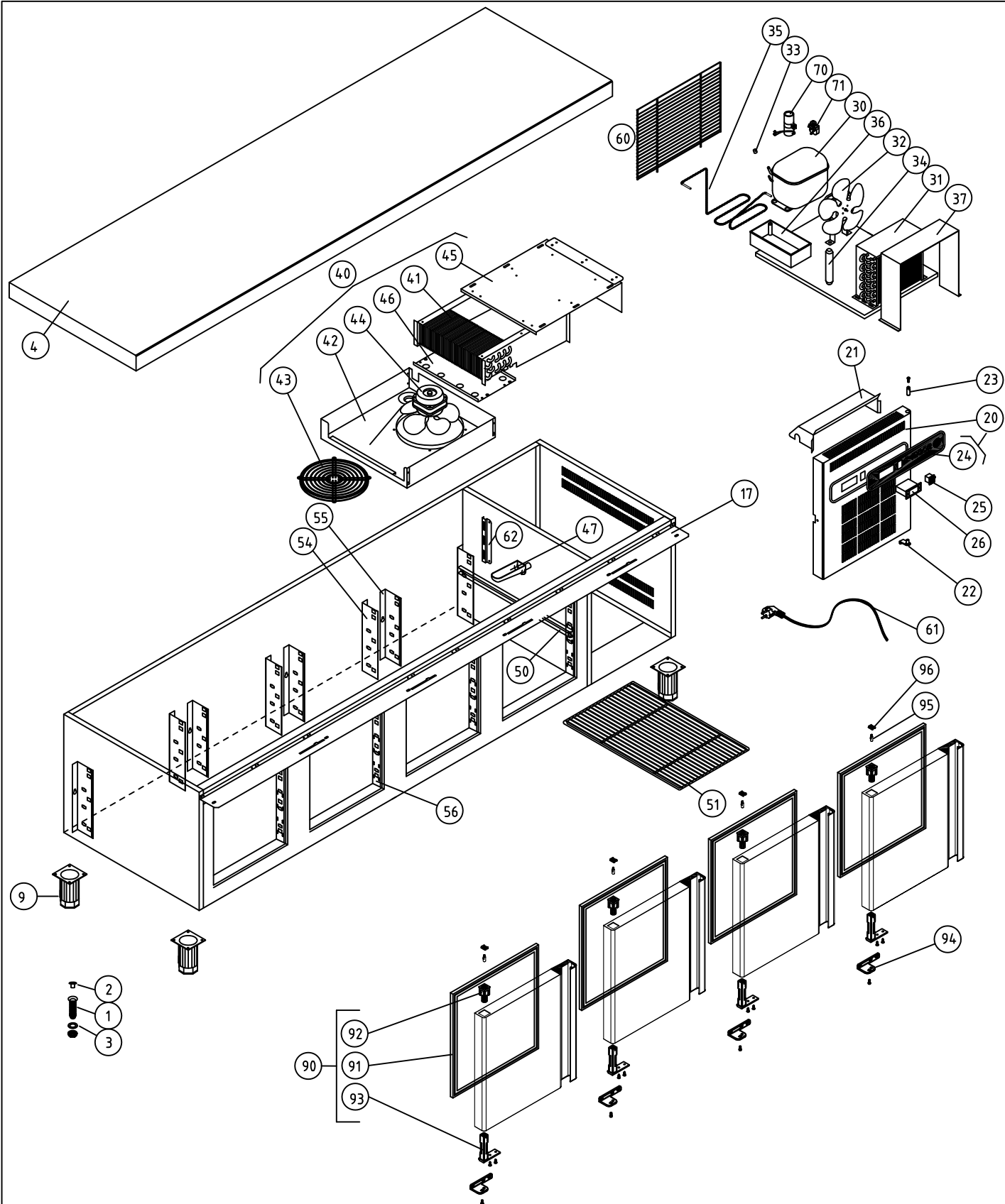

COTAS SIN TOLERANCIA DIN 7168-f						COD. PIEZA: 148317100000								
Material: MATERIAL ESPESOR						SUSTITUYE A:								
Acabado: ACABADO						SUSTITUIDO POR:								
ANGULAR	GRADO TOLERANCIA	FINO	MEDIO	GRUESO	COMUN A	MODELO	Ud.	MODELO	Ud.	MODELO	Ud.	MODELO	Ud.	MODELO
	HASTA 10 mm		±1°	±1° 30'		MFP-135 BP	1							
	MAS DE 10 A 50 mm		±30'	±50'										
	MAS DE 50 A 120 mm		±20'	±25'										
	MAS DE 120 A 400 mm		±10'	±15'										
	MAS DE 400 mm		±5'	±10'										
LINEAL	GRADO TOLERANCIA	FINO	MEDIO	GRUESO	A4	Nombre	Fecha		 FAGOR FRI					
	HASTA 3 mm	±0,05	±0,10	±0,15	Dibujado	A.J.GONZALEZ	Dic-2010							
	MAS DE 3 A 6 mm	±0,05	±0,10	±0,20	Modificado									
	MAS DE 6 A 30 mm	±0,10	±0,20	±0,50	Escala	1:22		RECAMBIOS MFP-135-BP						
	MAS DE 30 A 120 mm	±0,15	±0,30	±0,80			Código máquina: CODIGO							
	MAS DE 120 A 400 mm	±0,20	±0,50	±1,20										
MAS DE 400 A 1000 mm	±0,30	±0,80	±2,00											
MAS DE 1000 A 2000 mm	±0,50	±1,20	±3,00											



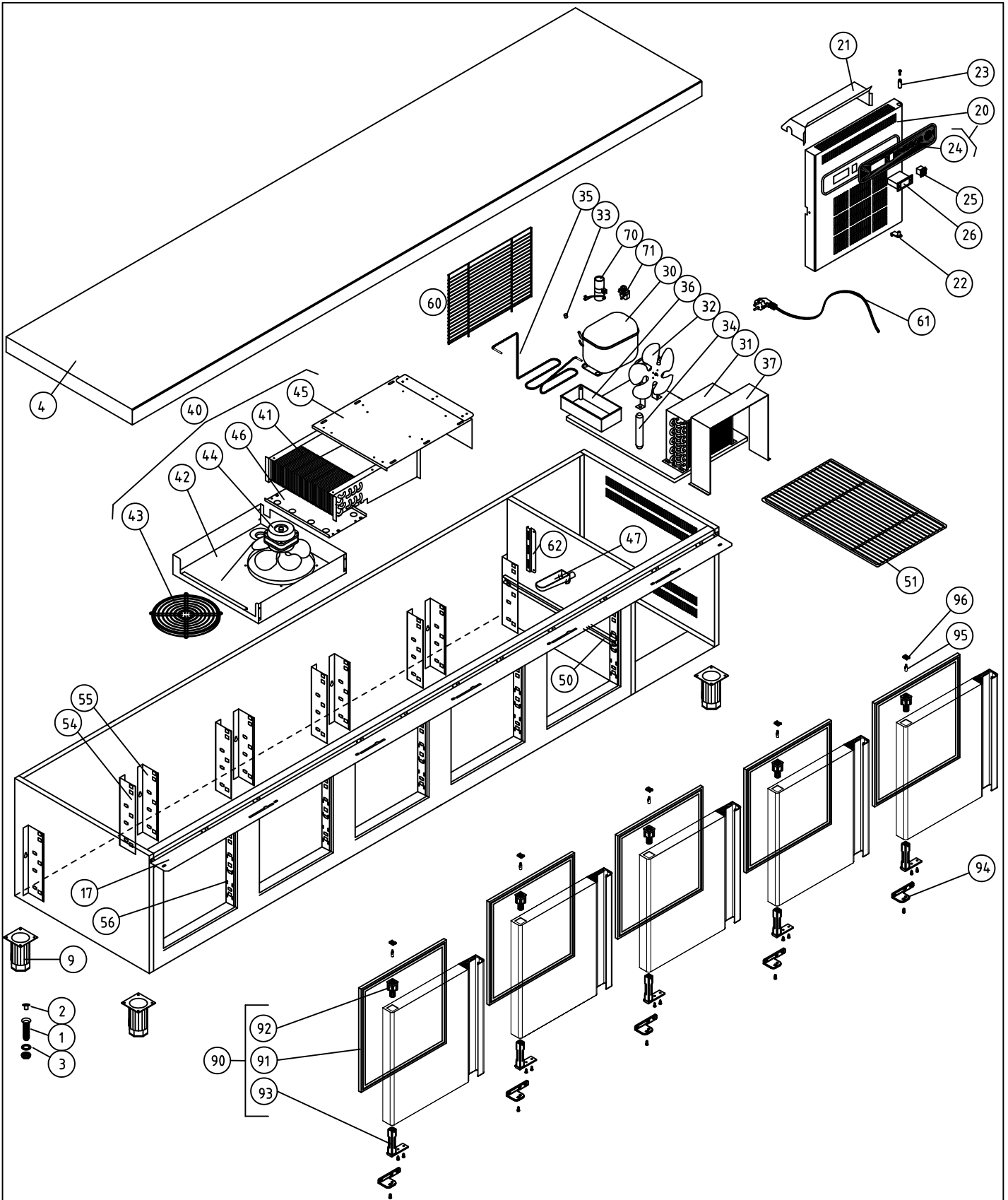

COTAS SIN TOLERANCIA DIN 7168-f COD. PIEZA: 148316100000

Material: MATERIAL ESPESOR				SUSTITUYE A:										
Acabado: ACABADO				SUSTITUIDO POR:										
ANGULAR	GRADO TOLERANCIA	FINO	MEDIO	GRUESO	COMUN A	MODELO	Ud.	MODELO	Ud.	MODELO	Ud.	MODELO	Ud.	MODELO
	HASTA 10 mm		±1°	±1° 30'		MFP-225 BP	1							
	MAS DE 10 A 50 mm		±30'	±50'										
	MAS DE 50 A 120 mm		±20'	±25'										
LINEAL	MAS DE 120 A 400 mm		±10'	±15'										
	MAS DE 400 mm		±5'	±10'										
	GRADO TOLERANCIA	FINO	MEDIO	GRUESO	A4	Nombre		Fecha		 FAGOR FRI				
	HASTA 3 mm		±0,05	±0,10	±0,15	Dibujado	A.J.GONZALEZ		Dic-2010					
	MAS DE 3 A 6 mm		±0,05	±0,10	±0,20	Modificado								
	MAS DE 6 A 30 mm		±0,10	±0,20	±0,50	Escala	RECAMBIOS MFP-225-BP				Código máquina: CODIGO			
MAS DE 30 A 120 mm		±0,15	±0,30	±0,80	1:22									
MAS DE 120 A 400 mm		±0,20	±0,50	±1,20										
MAS DE 400 A 1000 mm		±0,30	±0,80	±2,00										
MAS DE 1000 A 2000 mm		±0,50	±1,20	±3,00										

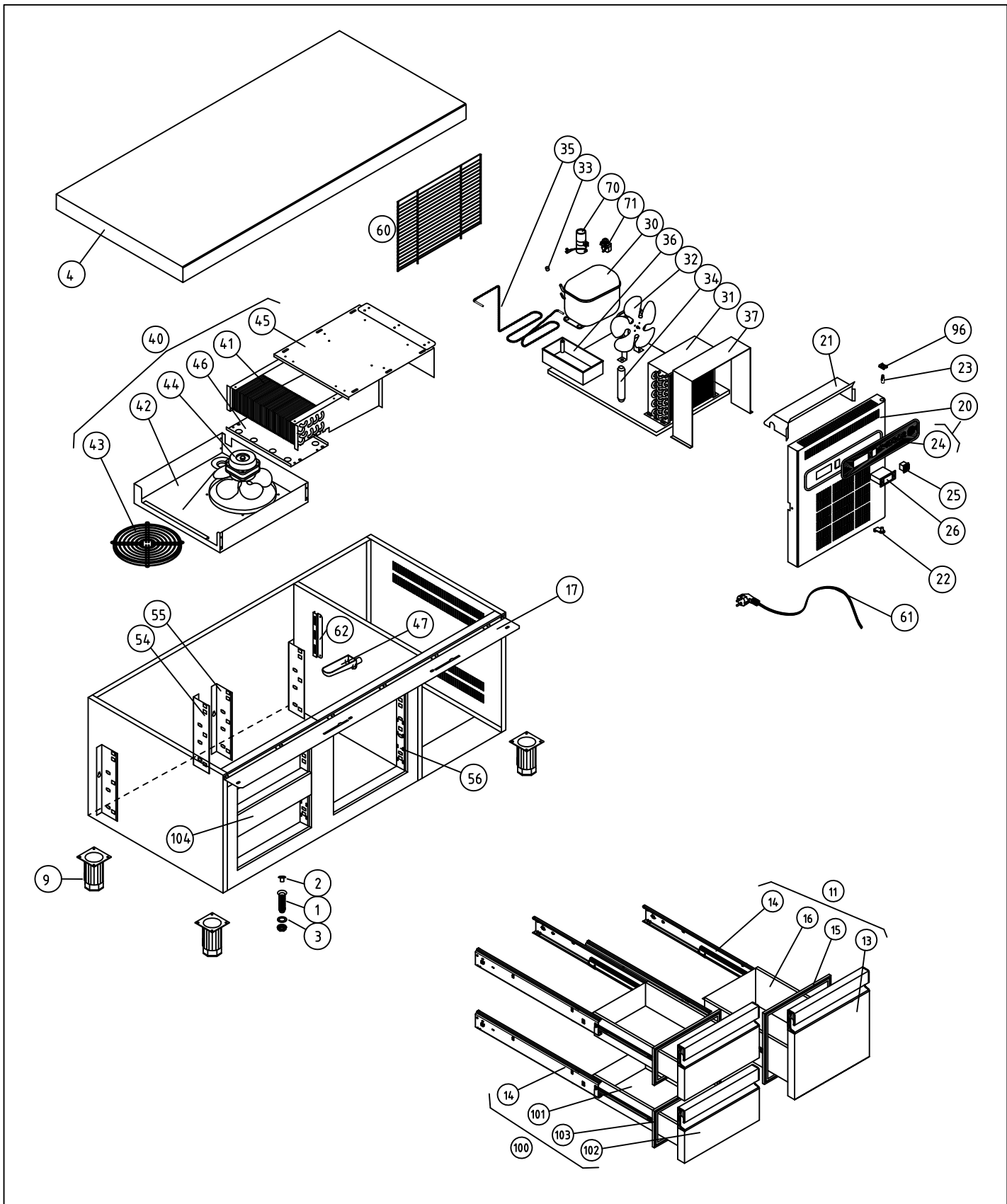

COTAS SIN TOLERANCIA DIN 7168-f				Material: MATERIAL ESPESOR				COD. PIEZA: 148318100000				
GRADO TOLERANCIA				Acabado: ACABADO				SUSTITUYE A:				
HASTA 10 mm								SUSTITUIDO POR:				
ANGULAR	FINO	MEDIO	GRUESO	COMUN A	MODELO	Ud.	MODELO	Ud.	MODELO	Ud.	MODELO	
	MAS DE 10 A 50 mm	±1°	±1° 30'		MFP-270 BP	1						
	MAS DE 50 A 120 mm	±30'	±50'									
	MAS DE 120 A 400 mm	±20'	±25'									
	MAS DE 400 mm	±10'	±15'									
LINEAL	FINO	MEDIO	GRUESO	A4	Nombre		Fecha		 FAGOR FRI			
	HASTA 3 mm	±0,05	±0,10	±0,15	Dibujado	A.J.GONZALEZ		Dic-2010				
	MAS DE 3 A 6 mm	±0,10	±0,20	±0,50	Modificado							
	MAS DE 6 A 30 mm	±0,15	±0,30	±0,80	Escala	1:22		RECAMBIOS MFP-270-BP				
	MAS DE 30 A 120 mm	±0,20	±0,50	±1,20				Código máquina:				
MAS DE 120 A 400 mm	±0,30	±0,80	±2,00				CODIGO					
MAS DE 400 A 1000 mm	±0,50	±1,20	±3,00									



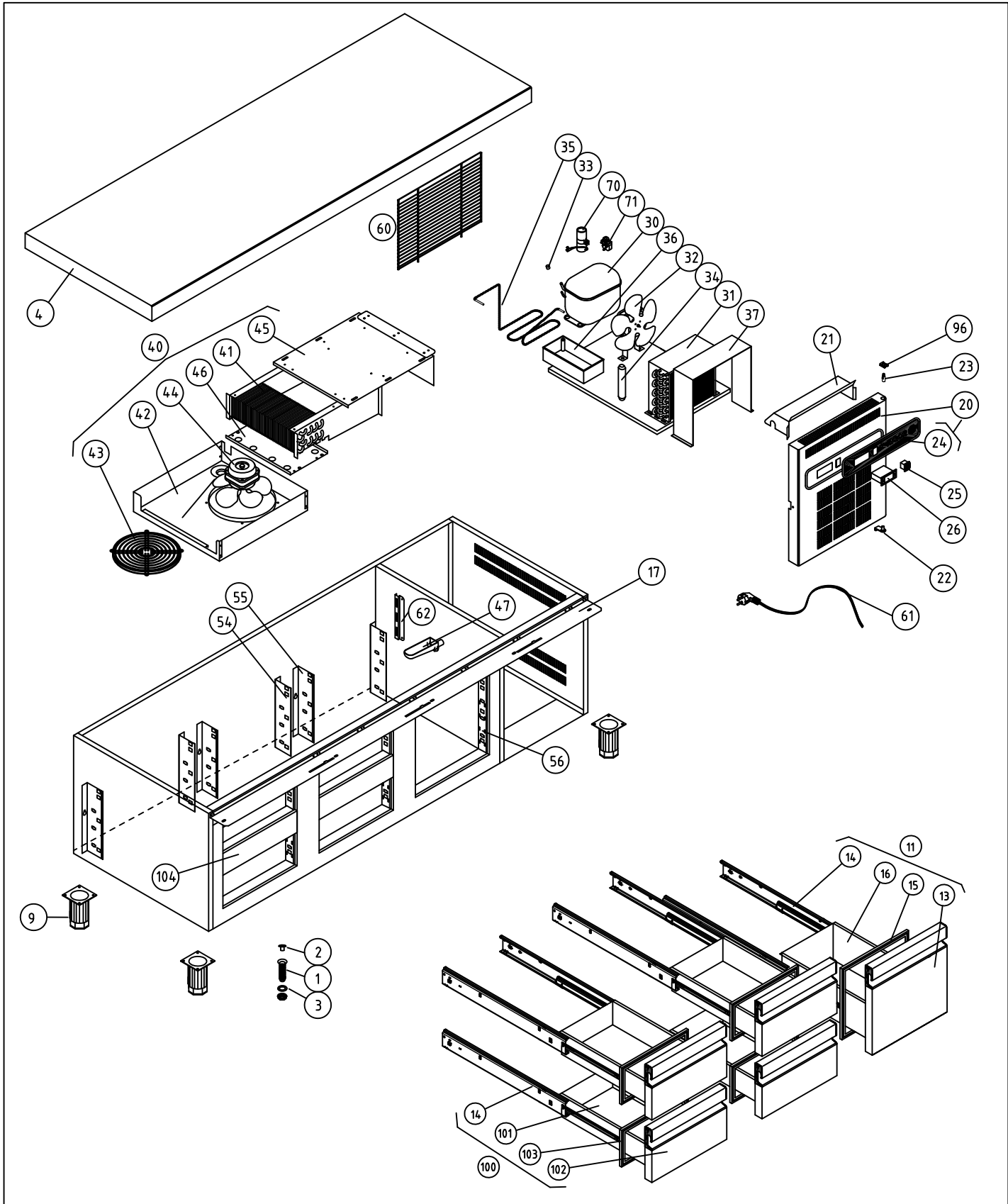

COTAS SIN TOLERANCIA DIN 7168-f						Material: .				COD. PIEZA: 148317200000			
GRADO TOLERANCIA						Acabado: .				SUSTITUYE A:			
HASTA 3 mm						COMUN A				SUSTITUIDO POR:			
FINO MEDIO GRUESO						MODELO Ud.		MODELO Ud.		MODELO Ud.		MODELO Ud.	
MAS DE 10 A 50 mm						MFP-135 B2 1							
MAS DE 50 A 120 mm													
MAS DE 120 A 400 mm													
MAS DE 400 mm													
GRADO TOLERANCIA						A4		Nombre		Fecha		 FAGOR FRI	
HASTA 3 mm						Dibujado		A.J.GONZALEZ		Dic-2010			
MAS DE 3 A 6 mm						Modificado							
FINO MEDIO GRUESO						Escala		RECAMBIOS MFP-135-B2				Código máquina:	
MAS DE 6 A 30 mm						1:22							
MAS DE 30 A 120 mm													
MAS DE 120 A 400 mm													
MAS DE 400 A 1000 mm													
MAS DE 1000 A 2000 mm													



COTAS SIN TOLERANCIA DIN 7168-f						Material: .				COD. PIEZA: 148315200000			
GRADO TOLERANCIA						Acabado: .				SUSTITUYE A:			
HASTA 10 mm						FINO				SUSTITUIDO POR:			
MAS DE 10 A 50 mm						MEDIO				MODELO			
MAS DE 50 A 120 mm						GRUESO				Ud.			
MAS DE 120 A 400 mm						±1°				MODELO			
MAS DE 400 mm						±1° 30'				Ud.			
ANGULAR						COMUN A				MODELO			
HASTA 3 mm						±30'				Ud.			
MAS DE 3 A 6 mm						±20'				MODELO			
MAS DE 6 A 30 mm						±10'				Ud.			
MAS DE 30 A 120 mm						±5'				MODELO			
MAS DE 120 A 400 mm						±10'				Ud.			
LINEAL						A4				Nombre			
HASTA 3 mm						±0,05				Fecha			
MAS DE 3 A 6 mm						±0,10				Dibujado			
MAS DE 6 A 30 mm						±0,20				A.J.GONZALEZ			
MAS DE 30 A 120 mm						±0,30				Modificado			
MAS DE 120 A 400 mm						±0,50				Escala			
MAS DE 400 A 1000 mm						±0,80				1:22			
MAS DE 1000 A 2000 mm						±1,20				RECAMBIOS MFP-180-B2			
										Código máquina:			

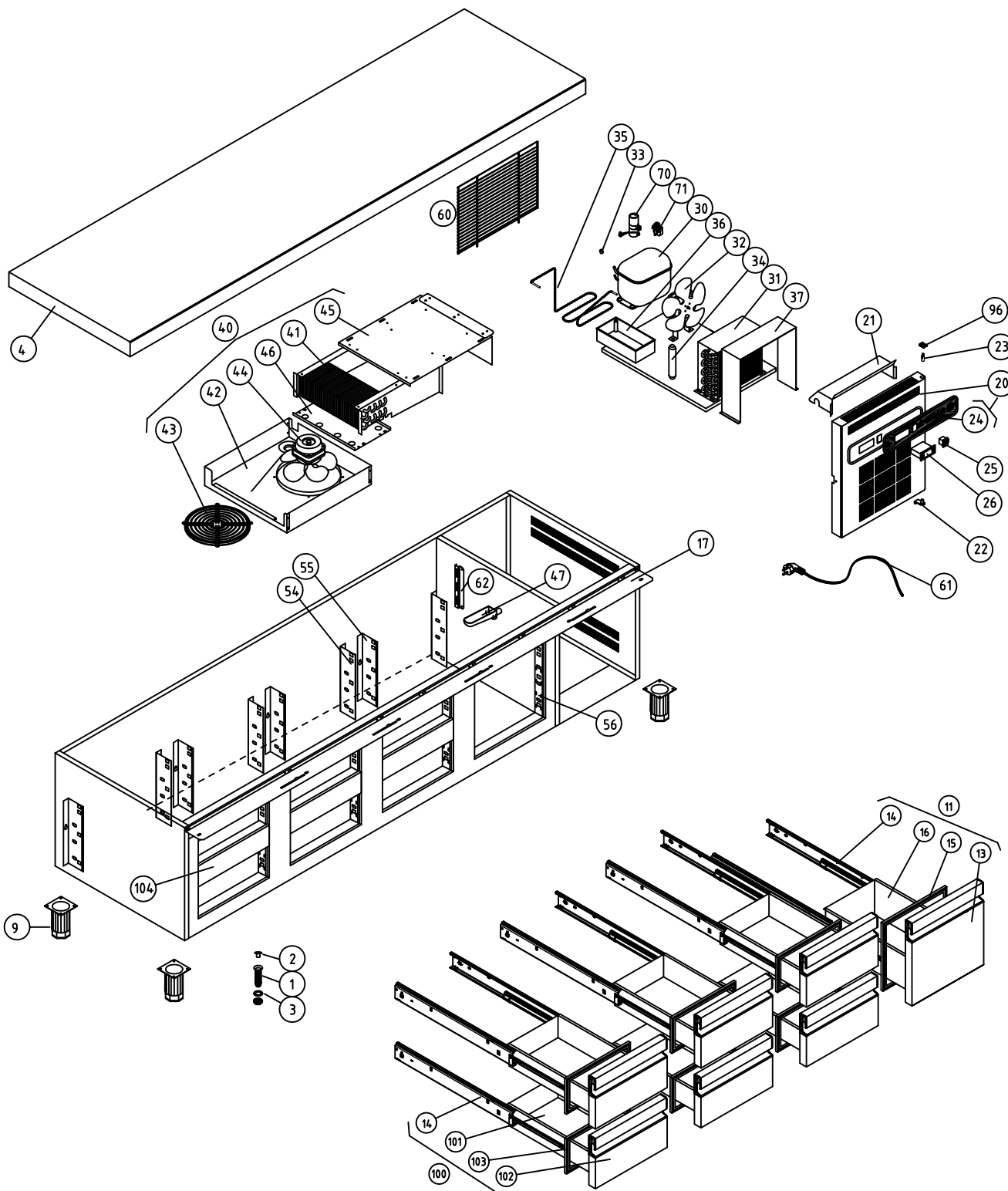



COTAS SIN TOLERANCIA DIN 7168-f						Material: .				COD. PIEZA: 148316200000									
GRADO TOLERANCIA						Acabado: .				SUSTITUYE A:									
ANGULAR	HASTA 10 mm	FINO	MEDIO	GRUESO		SUSTITUIDO POR:													
	MAS DE 10 A 50 mm		±1°		±1° 30'														
	MAS DE 50 A 120 mm		±30'		±50'														
	MAS DE 120 A 400 mm		±20'		±25'														
	MAS DE 400 mm		±10'		±15'														
COMUN A						MODELO	Ud.	MODELO	Ud.	MODELO	Ud.	MODELO	Ud.	MODELO					
						MFP-225 B2	1												
LINEAL						A4		Nombre		Fecha		 FAGOR FRI							
GRADO TOLERANCIA						Dibujado		A.J.GONZALEZ		Dic-2010									
HASTA 3 mm						Modificado						RECAMBIOS MFP-225-B2							
MAS DE 3 A 6 mm						Escala										Código máquina:			
MAS DE 6 A 30 mm						1:25													
MAS DE 30 A 120 mm																			
MAS DE 120 A 400 mm																			
MAS DE 400 A 1000 mm																			
MAS DE 1000 A 2000 mm																			

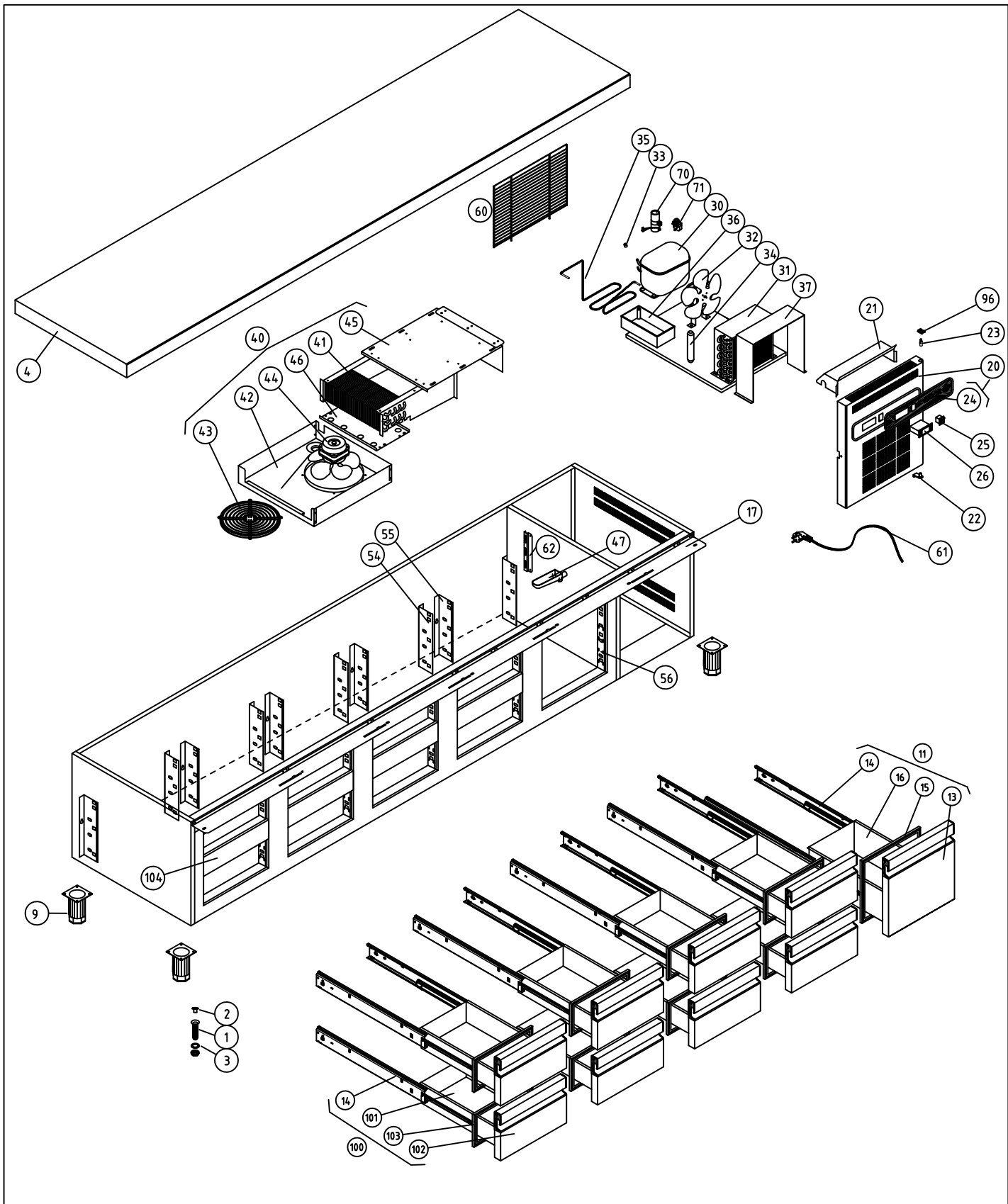

COTAS SIN TOLERANCIA DIN 7168-f						COD. PIEZA: 148318200000								
Material: .						SUSTITUYE A: .								
Acabado: .						SUSTITUIDO POR: .								
ANGULAR	GRADO TOLERANCIA	FINO	MEDIO	GRUESO	COMUN A	MODELO	Ud.	MODELO	Ud.	MODELO	Ud.	MODELO	Ud.	MODELO
	HASTA 10 mm		±1°	±1° 30'		MFP-270 B2	1							
	MAS DE 10 A 50 mm		±30'	±50'										
	MAS DE 50 A 120 mm		±20'	±25'										
LINEAL	MAS DE 120 A 400 mm		±10'	±15'	Escala	Nombre				Fecha				
	MAS DE 400 mm		±5'	±10'		A4				Dic-2010				
	GRADO TOLERANCIA	FINO	MEDIO	GRUESO		Dibujado				A.J.GONZALEZ				
	HASTA 3 mm		±0,05	±0,10		±0,15	Modificado							
MAS DE 3 A 6 mm		±0,05	±0,10	±0,20	Escala				1:25					
MAS DE 6 A 30 mm		±0,10	±0,20	±0,50	RECAMBIOS MFP-270-B2				Código máquina:					
MAS DE 30 A 120 mm		±0,15	±0,30	±0,80										
MAS DE 120 A 400 mm		±0,20	±0,50	±1,20										
MAS DE 400 A 1000 mm		±0,30	±0,80	±2,00										
MAS DE 1000 A 2000 mm		±0,50	±1,20	±3,00										

