

M1 MESA SANDWICHES

COD. PIEZA: X

COTAS SIN TOLERANCIA DIN 7168-f

Material:

SUSTITUYE A:

Acabado:

SUSTITUIDO POR:

	GRADO TOLERANCIA	FINO	MEDIO	GRUESO
	HASTA 10 mm		±1°	
MAS DE 10 A 50 mm		±30'		±50'
MAS DE 50 A 120 mm		±20'		±25'
MAS DE 120 A 400 mm		±10'		±15'
MAS DE 400 mm		±5'		±10'

	GRADO TOLERANCIA	FINO	MEDIO	GRUESO
	HASTA 3 mm		±0,05	±0,10
MAS DE 3 A 6 mm		±0,05	±0,10	±0,20
MAS DE 6 A 30 mm		±0,10	±0,20	±0,50
MAS DE 30 A 120 mm		±0,15	±0,30	±0,80
MAS DE 120 A 400 mm		±0,20	±0,50	±1,20
MAS DE 400 A 1000 mm		±0,30	±0,80	±2,00
MAS DE 1000 A 2000 mm		±0,50	±1,20	±3,00

COMÚN A

MODELO	Ud.	MODELO	Ud.	MODELO	Ud.	MODELO	Ud.
MEP-100	1						

A4	Nombre	Fecha	FAGOR FAGOFRI s.a.
Dibujado	MJGG	13-3-03	
Modificado	.	.	

Escala	1:20	RECAMBIOS MEP-100 CON TAPA	Código máquina: CODIGO
--------	------	----------------------------	---------------------------

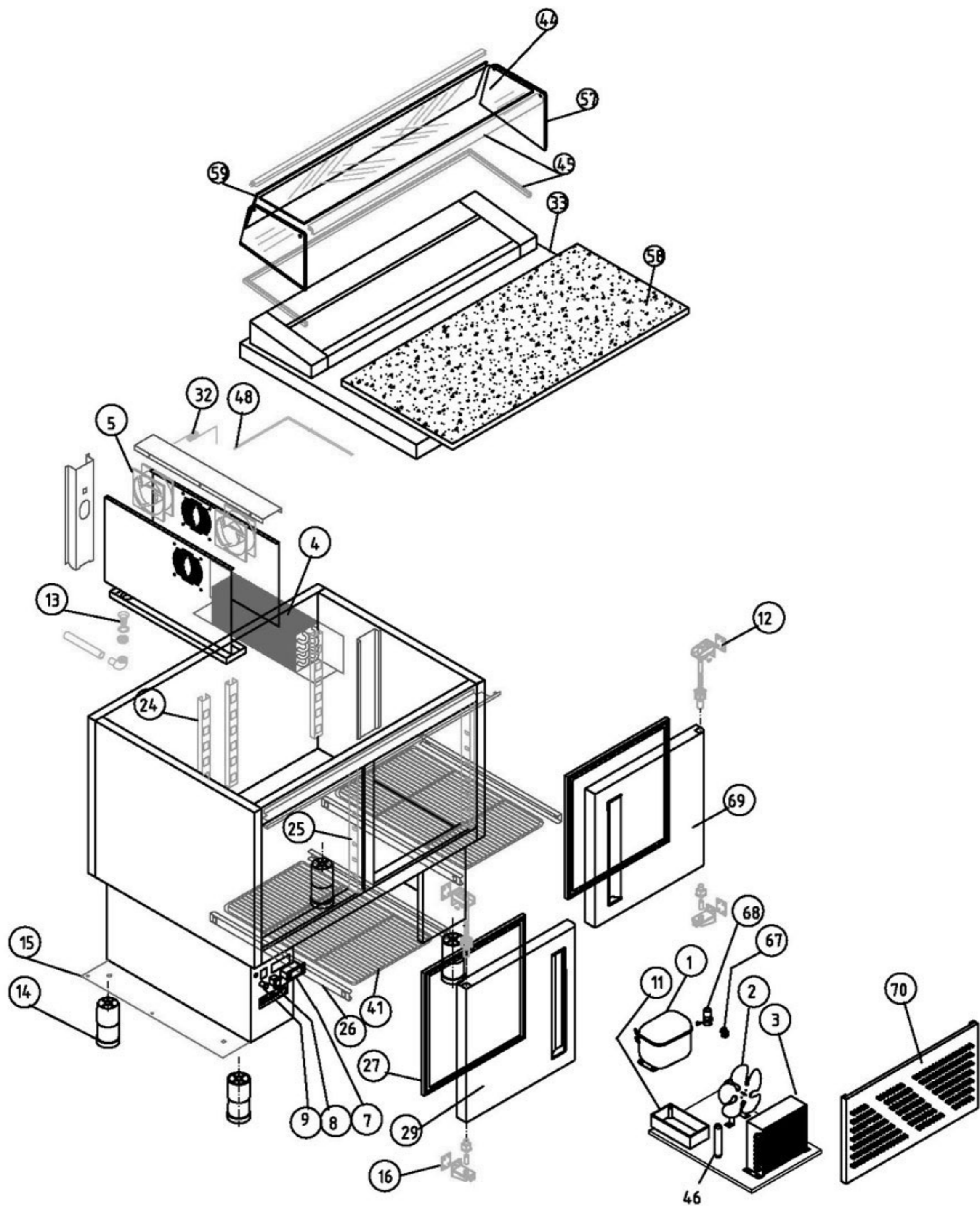

M1 MESA SANDWICHES

COD. PIEZA: X

COTAS SIN TOLERANCIA DIN 7168-f

	GRADO TOLERANCIA			
	FINO	MEDIO	GRUESO	
ANGULAR	HASTA 10 mm	±1°	±1° 30'	
	MAS DE 10 A 50 mm	±30'	±50'	
	MAS DE 50 A 120 mm	±20'	±25'	
	MAS DE 120 A 400 mm	±10'	±15'	
	MAS DE 400 mm	±5'	±10'	
LINEAL	HASTA 3 mm	±0,05	±0,10	±0,15
	MAS DE 3 A 6 mm	±0,05	±0,10	±0,20
	MAS DE 6 A 30 mm	±0,10	±0,20	±0,50
	MAS DE 30 A 120 mm	±0,15	±0,30	±0,80
	MAS DE 120 A 400 mm	±0,20	±0,50	±1,20
	MAS DE 400 A 1000 mm	±0,30	±0,80	±2,00
	MAS DE 1000 A 2000 mm	±0,50	±1,20	±3,00

Material:

Acabado:

SUSTITUYE A:

SUSTITUIDO POR:

COMÚN A	MODELO	Ud.	MODELO	Ud.	MODELO	Ud.	MODELO	Ud.	MODELO
		MEP-100	1						

A4	Nombre	Fecha
Dibujado	MJGG	13-3-03
Modificado	.	.

FAGOR
FAGOFRI s.a.



Escala: 1:20

Código máquina: CODIGO

RECAMBIOS MEP-100 CON CÚPULA FAGOR

RECAMBIOS MESAS FRÍAS

revisión 01-03-2003



FAGOFRI S.A.

MODELOS

MEP-100

MEP-100-G

Nº	CÓDIGO	DESCRIPCIÓN	SANDWICHES	
			MEP-100	MEP-100-G
1	6021010004	COMPR.FR-7,5-G R134A	1	1
2	6021050002	VENTILADOR 10W PATA PALA 220V	1	1
3	6029020002	CONDENSADOR 9x2	1	1
4	M129010007	BAT.MEP-100 B6T3R33A4S18T(PINTADO)	1	1
5	6021050008	VENTILADOR 120X120 CON BOLAS	2	2
7	6021350015	TERMOSTATO TERM.REFRIG ID 961F	1	1
8	6021130001	INTERRUPTOR BIPOL.AMB.ON/OFF	1	1
9	6021130003	PILOTO AMBAR FUNCION.	1	1
11	6003010023	BANDEJA EVAPORACION AUTOMÁTICA	1	1
12	V169090002	BISAGRA SISTEMA GIRO A DCHA	1	1
13	6003010062	DESAGÜE COMPL-1/2 LARGO GRIS	1	1
14	6007050015	PATA REGUL. 50X95 BAJOS	4	4
15	M161250010	CHASIS RODAP.BANCADA MEP-100 PINTADO	1	1
16	V169090001	BISAGRA SISTEMA GIRO A IZDA	1	1
23	M109050017	CREMALL.LAT.RESPALDO MEP-100	4	4
26	6033050011	GUIA BAJO GN 1/1 L=549 MM	8	8
27	6045010007	BURLETE 400X420 MEP-100	2	2
29	M169010023	PUERTA MEP-100 IZDA	1	1
32	M107020001	CAPILAR 1x3300	1	1
33	M181010052	ENCIMERA MEP-100 C/CÚPULA FAGOR		1
33	M181010051	ENCIMERA C/TAPA CUBETA MEP-100	1	
35	M109250002	PROT.ENCIMERA 100	1	1
36	6001050040	AGLOM.990X485X19 ESTANT.MMC-250	1	1
41	6027010003	PARRILLA GN1/1 530x325	1	1
44	6035050033	CRISTAL 907X149X4 MEP-100 FAGOR		1
44	6033010002	ASA CROMADA PARA MEP	1	
45	M107130001	PERFIL UNION CRISTAL MEP-100 A 908		2
45	M107130002	PERFIL ALUMINIO DCHO.CUPULA MEP-100		1
45	M107130003	PERFIL ALUMINIO IZDO.CUPULA MEP-100		1
45	M107130004	PERFIL ALUMINIO LONG. CUPULA MEP-100		1
45	6033110003	JGO.SOPORTE ENSALADERA MEP-100	1	
46	6047010003	FILTRO DESHIDRAT.40GR 1/4X1/4	1	
48	6021350013	SONDA TERMOST.REF NTC 15KOhm	1	
56	M109010041	PERFIL DIVISORIO GN-1/1	2	
57	6039010008	JGO.COST.METACRILATO MEP-100 FAGOR		1
57	M109010040	TAPA CUBETAS MEP-100	1	
58	6031010027	ENCIM.MARMOL 933X440X20 MEP-100		1
58	6003010159	TABLA POLIETILENO 930X300X20	1	
59	6035050032	CRISTAL 907X149X4 MEP-100 FAGOR		1
67	6021010045	RELE ARRANQUE COMPRESOR FR-7,5-G 6001	1	1
68	6021010037	CONDENSADOR ARRANQUE FR 17U5015 80microF	1	1
69	M169010024	PUERTA MEP-100 DCHA	1	1
70	M109010382	REJILL FRONT.Y TRAS.MEP-100	2	2