

DESPIECES

MESAS MCN

GASTRO



Rev.: Feb-2011

**RECAMBIOS
MESAS MCN-GN
FEB-2011**



MODELOS

MCN-135-GN	MCN-180-GN	MCN-270-GN
------------	------------	------------

Nº	CÓDIGO	DESCRIPCIÓN	MCN-135-GN	MCN-180-GN	MCN-270-GN
1	6003010326	DESAG COMPL 3/4 GRIS+TUERCA	1	1	1
2	6003010262	TAPON DESAGÜE DE 3/4 CIEGO	1	1	1
3	6003010327	JUNTA GOMA DESAGÜE 3/4	1	1	1
4	M181010505	ENCIM.MCP-135	1		
4	M181010471	ENCIM.MCP-180		1	
4	M181010519	ENCIM.MCP-270			1
9	6007050017	PATA REGULAB ARM GASTRO	4	4	6
10	M169010093	PUERTA MFP/MFN FAGOR	2	3	5
11	6045010119	BURLETE MFP 385x580 MFP	4	6	10
12	6003010136	CAJA ALOJAMIENTO MUELLE GRIS	4	6	10
13	6033010100	BIS.TRSD DOBL MUELLE DV-2608	4	6	10
14	6033010129	SOP.BISAG.INF.IZD.	2	3	5
15	6033090104	EJE ROSCA EXT.30X10INOX MESAS	4	6	10
16	6025130045	TUERC.RAPIDA TRT M6-2	6	8	12
17	M109050552	SOPOR.SUP.PUERTAS MFP-135	1		
17	M109050242	SOP.SUP.PUERTAS MFP-180		1	
17	M109050555	SOP.SUP.PUERT. MFP-225			
17	M109050565	SOP.SUP.PUERTAS MFP-270			1
18	M109050698	SOP.SUPER.PUERTAS MFP-135 GI	1		
18	M109050700	SOP.SUP.PUERTAS MFP-180-GI		1	
18	M109050704	SOP.SUP.PUERTAS MFP-270 GI			1
20	M177010076	CHAP.CUAD.MAND.MSN	1	1	1
21	M109050532	PROTECC.INST.ELECT.	1	1	1
22	6033090090	SOPORTE ZAMAK GIRO REJILLA	2	2	2
23	6033090104	EJE ROSCA EXT.30X10INOX MESAS	2	2	2
24	6023010408	PEG.CUAD.FAGOR REFR.347,5X60	1	1	1
25	6021130001	INT.BIP.AMB.O/I CONTAC.REFORZ.	1	1	1
26	6021350010	TERM CAREL CONG.PYCO1LO016	1	1	1
28	M177010087	CH.REJ.CUAD TRASERA	1	1	1
30	6021010001	COMPR.SC-12-CL R404A	1		
30	6021010160	COMPR.NEK-2168-GK 220V50HZ		1	
30	6021010006	COMPR.J-2192-GK R404A ASPERA			1
31	6029020013	CONDENSADOR 10X4 NEUTRO	1		
31	6029020005	CONDENSADOR 10x4 TECHO		1	
31	6029020019	CONDENSADOR 20X4 BAFLE			1
32	6021050002	VENTILADOR 10W PATA PALA 220V	1	1	2
33	6021310003	VALVULA OBUS COMPLETA RF.HB-1S	1	1	1
34	6047010003	FILTRO DESHIDRAT.40GR 1/4X1/4	1	1	1
35	M107010038	SERP.EV.AUT.5/16 PINT.MSN15020	1		
35	M107010040	TUB.EV.AUT5/16 MFN PINT.EMBRA		1	
36	6003010023	BANDEJA EVAPORACION AUTOMÁTICA	1	1	
36	M109050521	BANDEJA EVAP AUT MSN-250/300			1
37	M109250127	OMEGA COND.9X2-REJ.MESAS-ARMAR	1	1	

RECAMBIOS
MESAS MCN-GN
FEB-2011



MODELOS

MCN-135-GN	MCN-180-GN	MCN-270-GN
------------	------------	------------

Nº	CÓDIGO	DESCRIPCIÓN	MCN-135-GN	MCN-180-GN	MCN-270-GN
38	6021250073	RESIST.EVAP.AUT.80W 3MT			1
40	M171010110	UD.EV. MSN150,200,135,180 COMP	1	1	
40	M171010075	UD.EV. MSN/MPN-250,300			1
41	6029010147	BAT.6T4R300A6S PINTADO.MESAS	1	1	
41	6029010025	EV.CONG.FC71B BAJO MSN250			1
42	M109250148	SUJ.VENTIL.MSP-150,200 COMPACT	1	1	
43	6027130004	REJILLA VENT.D.246 PINTADA	1	1	1
44	6021050066	VENTIL.EVAPOR.5W S/ARO S/PATAS	1	1	
45	M109250151	SOP.EVAP.MESAS EVAP.COMPACTO	1	1	
46	M109250150	CUBRER.BAT.6T4R300A6S EVAP.COM	1	1	
47	6003010192	CANALIZ AGUA 150 NEGRO CONG	1	1	1
50	6033050012	GUIA BAJ GN CENT L=613MM Y PES	8	12	20
51	6027010003	PARRIL. GN1/1 530x325	2	3	5
56	M109050747	CREM. MARC. MAGNETICO MSP-MFP	8	12	20
61	6021390022	MANG 3X1.5X2500 BL.SCHUKO 3T	1	1	1
62	M109050033	PROT SONDA 175x49	1	1	1
70	6021010035	COND.ARRANQ.SC 117U5017 80MF	1		
70	6021010165	CONDENSAD ARRANQUE NEK-2168-GK		1	
70	6021010038	COND.ARRA.J2192GK 2252019 98MF			1
71	6021010042	RELE ARRANQ COMPR.SC-12CL 6005	1		
71	6021010166	RELE ARRANQUE NEK-2168-GK		1	
71	6021010034	RELE COMPRESOR ASPERA J2192GK			1
80	6021250003	RESIST.MARCO GASTRO-1,20W	2	2	2
81	6021250004	RESIST.MARCO GASTRO-2, 20 W	2	4	8
82	6021250019	RESIST.BLIND.FC61-71 350W 1000	1	1	
82	6021250021	RESIST.BLIND.FC61-71 350W 2500			1
83	6021250011	RESIST.BANDEJA DEPART.18W	1	1	1
90	M169010100	PUE MFP/MFN. AP.DCH.	2	3	5
91	6033010130	SOP.BISAG.INF.DCH.	2	3	5

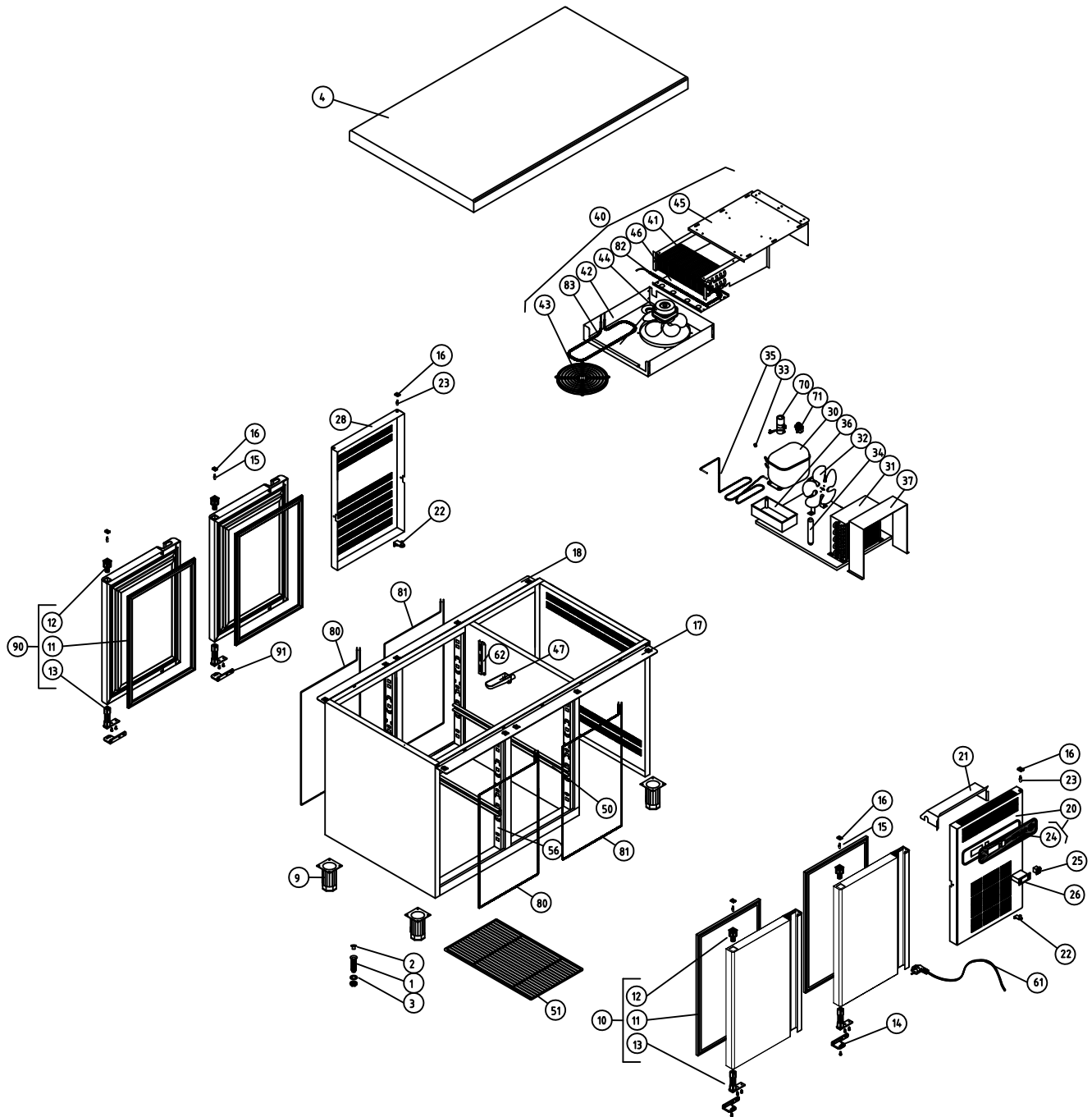

M1 MESAS FRÍAS

COD. PIEZA: 148321010000

COTAS SIN TOLERANCIA DIN 7168-f

Material: MATERIAL ESPESOR

SUSTITUYE A:

Acabado: ACABADO

SUSTITUIDO POR:

ANGULAR	GRADO TOLERANCIA	FINO	MEDIO	GRUESO
	HASTA 10 mm		±1°	±1° 30'
	MAS DE 10 A 50 mm		±30'	±50'
	MAS DE 50 A 120 mm		±20'	±25'
	MAS DE 120 A 400 mm		±10'	±15'
MAS DE 400 mm		±5'	±10'	

COMUN A	MODELO	Ud.	MODELO	Ud.	MODELO	Ud.	MODELO	Ud.	MODELO
	MCN-135-GN	1							

LINEAL	GRADO TOLERANCIA	FINO	MEDIO	GRUESO
	HASTA 3 mm	±0,05	±0,10	±0,15
	MAS DE 3 A 6 mm	±0,05	±0,10	±0,20
	MAS DE 6 A 30 mm	±0,10	±0,20	±0,50
	MAS DE 30 A 120 mm	±0,15	±0,30	±0,80
	MAS DE 120 A 400 mm	±0,20	±0,50	±1,20
MAS DE 400 A 1000 mm	±0,30	±0,80	±2,00	
MAS DE 1000 A 2000 mm	±0,50	±1,20	±3,00	

A4	Nombre	Fecha
Dibujado	A.J.GONZALEZ	Feb-2011
Modificado		



Escala 1:30

RECAMBIOS MCN-135-GN

Código máquina:

CODIGO

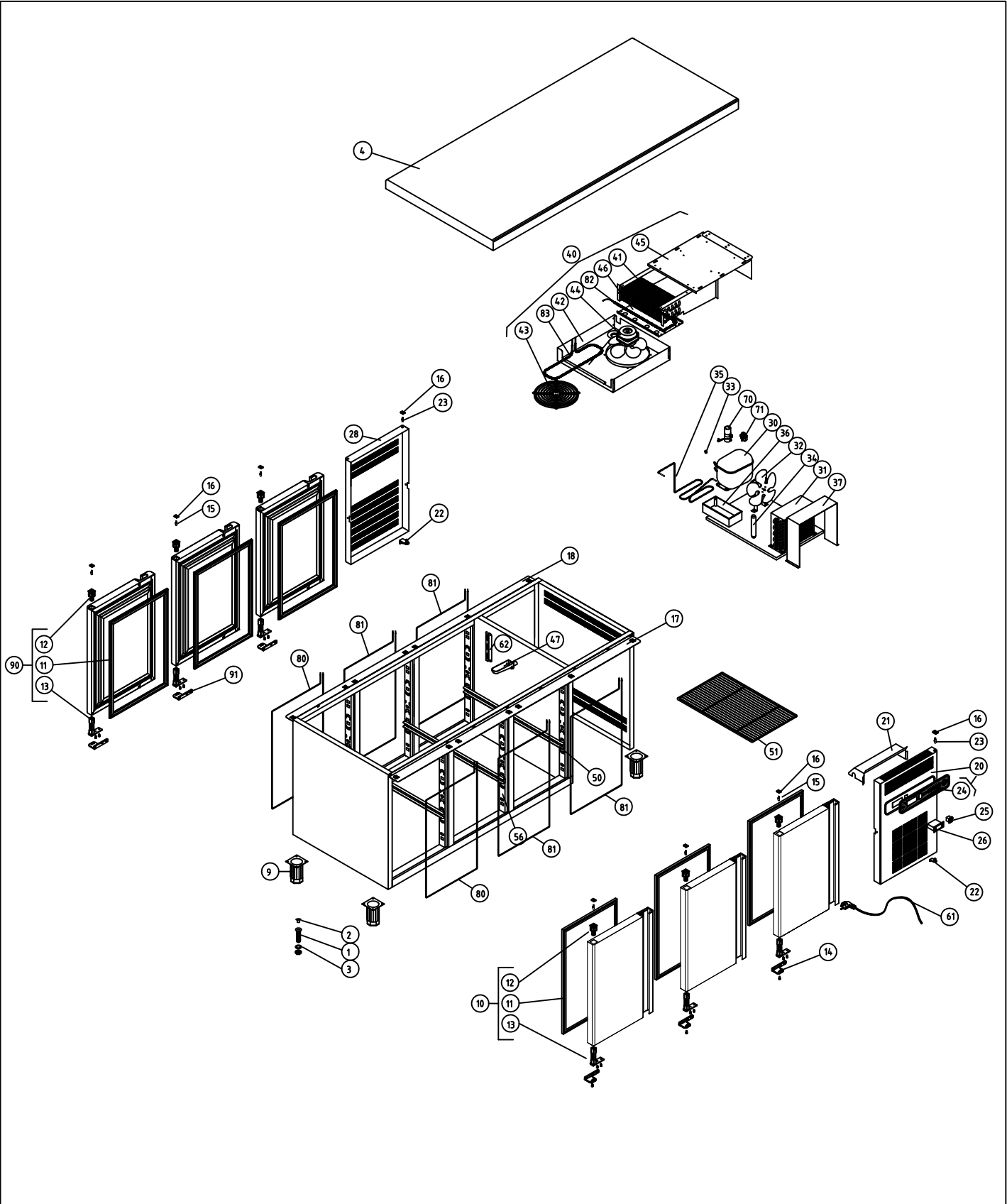

M1 MESAS FRÍAS COD. PIEZA: 14832201000

COTAS SIN TOLERANCIA DIN 7168-f SUSTITUYE A:

Material: SUSTITUIDO POR:

ANGULAR	GRADO TOLERANCIA	FINO	MEDIO	GRUESO	COMUN A	MODELO	Ud.	MODELO	Ud.	MODELO	Ud.	MODELO	Ud.	MODELO	Ud.
	HASTA 10 mm		±1°			±1° 30'	MCN-180-GN	1							
MAS DE 10 A 50 mm			±30'	±50'											
MAS DE 50 A 120 mm			±20'	±25'											
MAS DE 120 A 400 mm			±10'	±15'											
MAS DE 400 mm			±5'	±10'											

LINEAL	GRADO TOLERANCIA	FINO	MEDIO	GRUESO	A4	Nombre	Fecha	
	HASTA 3 mm		±0,05	±0,10	±0,15	Dibujado	A.J.GONZALEZ	
MAS DE 3 A 6 mm		±0,05	±0,10	±0,20	Modificado			
MAS DE 6 A 30 mm		±0,10	±0,20	±0,50				
MAS DE 30 A 120 mm		±0,15	±0,30	±0,80				
MAS DE 120 A 400 mm		±0,20	±0,50	±1,20				
MAS DE 400 A 1000 mm		±0,30	±0,80	±2,00				
MAS DE 1000 A 2000 mm		±0,50	±1,20	±3,00				

1:30
RECAMBIOS MCN-180-GN
Código máquina: CODIGO

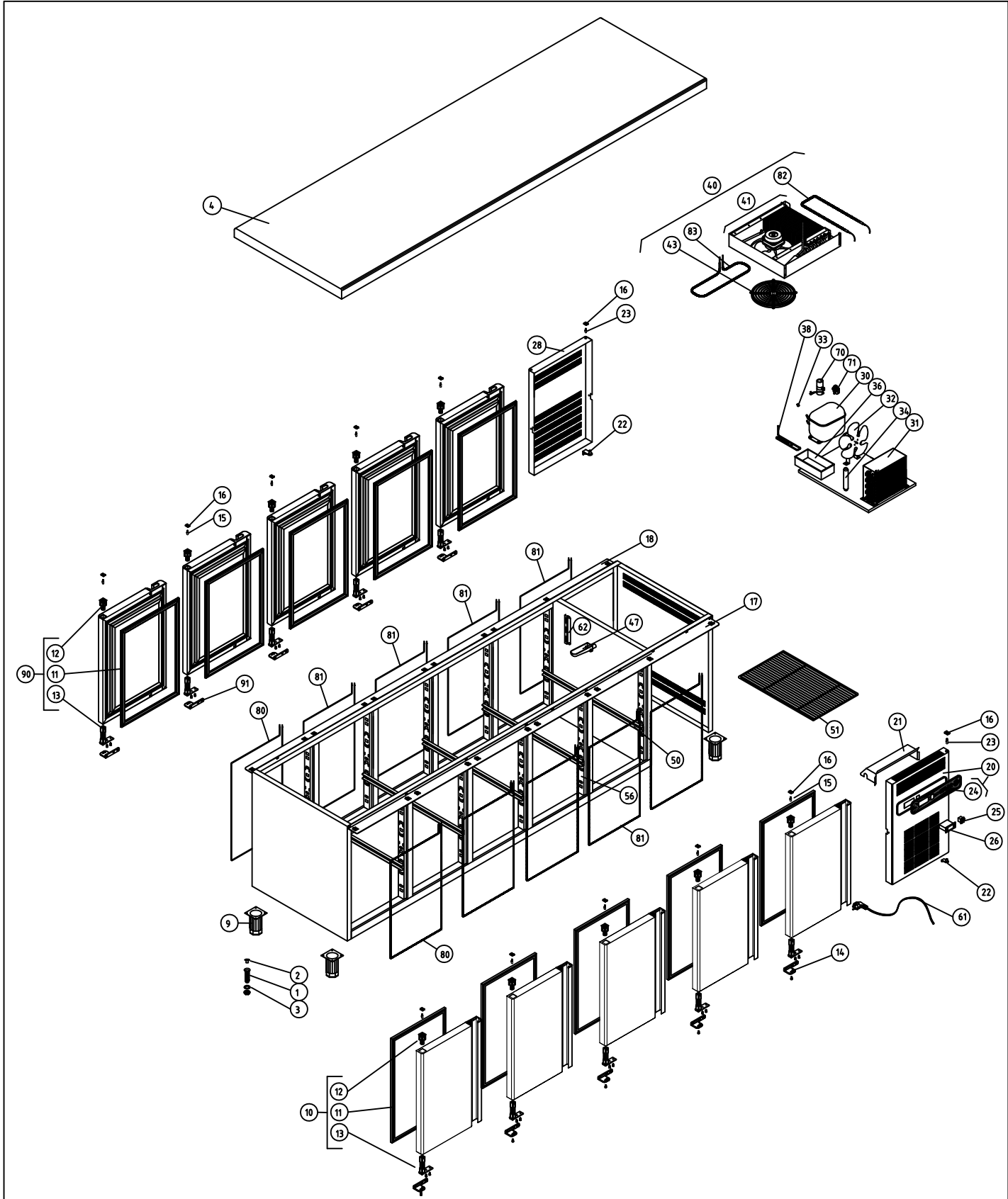

M1 MESAS FRÍAS				COD. PIEZA: 148324010000							
COTAS SIN TOLERANCIA DIN 7168-f				Material: .							
ANGULAR	GRADO TOLERANCIA	FINO	MEDIO	GRUESO	Acabado: .			SUSTITUYE A:			
	HASTA 10 mm		±1°	±1° 30'	SUSTITUIDO POR:						
	MAS DE 10 A 50 mm		±30'	±50'	MODELO	Ud.	MODELO	Ud.	MODELO	Ud.	MODELO
	MAS DE 50 A 120 mm		±20'	±25'	MCN-270-GN	1					
	MAS DE 120 A 400 mm		±10'	±15'							
MAS DE 400 mm		±5'	±10'								
LINEAL	GRADO TOLERANCIA	FINO	MEDIO	GRUESO	COMUN A						
	HASTA 3 mm		±0,05	±0,10	A4	Nombre	Fecha	FAGOR 			
	MAS DE 3 A 6 mm		±0,05	±0,10	Dibujado	A.J.GONZALEZ	Feb-2011	F A G O F R I			
	MAS DE 6 A 30 mm		±0,10	±0,20	Modificado			Código máquina:			
	MAS DE 30 A 120 mm		±0,15	±0,30	Escala	1:30			RECAMBIOS MCN-270-GN		
MAS DE 120 A 400 mm		±0,20	±0,50					CODIGO			
MAS DE 400 A 1000 mm		±0,30	±0,80								
MAS DE 1000 A 2000 mm		±0,50	±1,20								