

**RECAMBIOS
MPZ1
Revisión 08/10/10**



			MPZ1-150	MPZ1-200	MPZ1-250
			DSP.1	DSP.2	DSP.3

Nº	CODIGO	DENOMINACION	DSP.1	DSP.2	DSP.3
1	6003010326	DESAG COMPL 3/4 GRIS+TUERCA	1	1	1
2	6003010262	TAPON DESAGÜE DE 3/4 CIEGO	1	1	1
3	6003010327	JUNTA GOMA DESAGÜE 3/4	1	1	1
4	M181010609	ENCIM.C/EXPOSITOR.INC.MPZ1-150	1		
4	M181010611	ENCIM.C/EXPOSITOR.INC.MPZ1-200		1	
4	M181010613	ENCIM.C/EXPOSITOR.INC.MPZ1-250			1
5	M109011088	TAPA CUBETAS MPZ1-150	1		
5	M109011096	TAPA CUBETAS MPZ1-200		1	
5	M109011097	TAPA CUBETAS MPZ1-250			1
6	M109050300	CREMALL.RESP.DCHA.MFP 2006			1
7	M109050552	SOPOR.SUP.PUERTAS MFP-135 2006	1		
7	M109050242	SOPOR.SUP.PUERTAS MFP-180 2006		1	1
8	6007050017	PATA REGULAB ARM GASTRO	4	4	6
9	6025050010	TORN 4.8x25 ZINC DIN 7981	16	16	24
10	M169010093	PUERTA MFP	2	3	4
11	6045010119	BURLETE MFP 385x580 MFP2006	2	3	4
12	6003010136	CAJA ALOJAMIENTO MUELLE GRIS	2	3	4
13	6033010100	BIS.TRSD DOBL MUELLE DV-2608	2	3	4
14	M169090003	JGO.BISAG.APERT.IZDA MSP COMPLETO	2	3	4
15	M177010059	REJILL.CUAD.MANDOS FAGOR	1	1	1
16	M109050532	PROTECC.INST.ELECT.FAGOR 2006	1	1	1
17	6033090090	SOPORTE ZAMAK GIRO REJILLA	1	1	1
18	6033090064	EJE30x10VARIL INOX ROSC.INT M6	3	4	5
19	M177010065	CHAP.CUAD.MAND. FAGOR	1	1	1
20	6023010408	PEG.CUAD. FAGOR	1	1	1
21	M173010125	UD.CONDENS.MEP-135	1		
21	M173010126	UD.CONDENS.MEP-180		1	1
22	6021010007	COMPR.FR-8,5-G R134A	1		
22	6021010154	COMP. NEK6210Z		1	1
23	6029020002	CONDENSADOR 9x2	1		
23	6029020003	CONDENSADOR 9x3		1	1
24	6021050002	VENTILADOR 10W PATA PALA 220V	1	1	1
25	6021310003	VALVULA OBUS COMPLETA RF.HB-1S	1	1	1
26	6047010003	FILTRO DESHIDRAT.40GR 1/4X1/4	1	1	1
27	M107010003	SERP.EV.AUTOM.MEP-135 PINT.	1	1	1
28	M109050019	BANDEJA EVAP. AUTOMÁTICA MEP-135/180	1	1	1
29	M109250127	OMEGA COND.9X2-REJ.MESAS-ARMAR	1	1	1
30	6003010179	CODO DESAG. 1/2 90° A 15 mm	1	1	1
31	6021130001	INT.BIP.AMB.O/I CONTAC.REFORZ.	1	1	1
32	6021350018	TERMOS REFRI CAREL PYCO1RN515	1	1	1
33	6021450040	INST.ELECTRICA MEP-135	1		
33	6021450041	INST.ELECTRICA MEP-180		1	1
34	6029010125	BAT.5T4R330A4S MEP135/180 PIN	1	1	1
35	M109050033	PROT SONDA 175x49	1	1	1

**RECAMBIOS
MPZ1
Revisión 08/10/10**



MPZ1-150	MPZ1-200	MPZ1-250
DSP.1	DSP.2	DSP.3

Nº	CODIGO	DENOMINACION	DSP.1	DSP.2	DSP.3
36	6003010181	REJ.RESP.GRUPO 387X280POLICARB	1	1	1
37	M109170831	BASE PATAS MFP NUEVA	1	1	2
38	6003010033	DESA. 1/2 PULG.CUELL CORT+TUERC	1	2	2
39	6003010051	JUNTA GOMA DESAGÜE 1/2	1	2	2
40	6027010003	PARRIL. GN1/1 530x325	2	3	4
41	6033010002	ASA CROMADA PARA MEP	1	2	2
42	6021050008	VENTILADOR 120x120 CON BOLAS	2	4	4
43	M109050606	BANDEJA DESAG. MEP-135/180	1	2	2
44	6033010098	SOP.BISAG.DV2607 INF IZQ.	2	3	4
45	6025090027	TORN M6X10 INOX EXAGONAL	5	7	9
46	6025050073	TORN.4.8X32 INOX DIN 7982	6	8	10
47	M109050609	COSTADO EVAP. IZDA. MEP-135/180	1	2	2
48	6003010068	PISACABLES DE 90º	1	1	1
49	6021390006	MANG 3X1X2500 BL. SCHUKO 3T	1	1	1
50	6007170097	PERFIL EN U A 336 MM/90º	4	6	8
51	M109050277	CREMALL. MARCO MSP-MFP 2006 CAJ.	4	6	8
52	6025210009	ARANDELA ALA ANCHA M6 INOX	4	6	8
53	M109050608	COSTADO EVAP. DCHA. MEP-135/180	1	2	2
54	M109050298	CREMALL.LATER.DCHA.MFP 2006	1	1	1
55	M109050299	CREMALL.LATER.IZDA.MFP 2006	1	1	1
56	M109050611	CREMALLERA CENTRAL MEP	1	2	2
57	M109050614	TAPA CAJA EVAP. MEP-135/180	1	2	2
58	6033050015	GUIA SNACK.DT.CONG-MESA GN 562mm	8	12	16
59	M169090013	JGO. BISAG. TAPA MPZ-1	1	2	2
60	M109050301	CREMALL.RESP.IZDA.MFP			1
61	6029010140	BAT.5T4R330A4S MEP180 PIN S/TUB.		1	1
62	M109050555	SOP.SUP.PUERT.SUPL MFP225			1

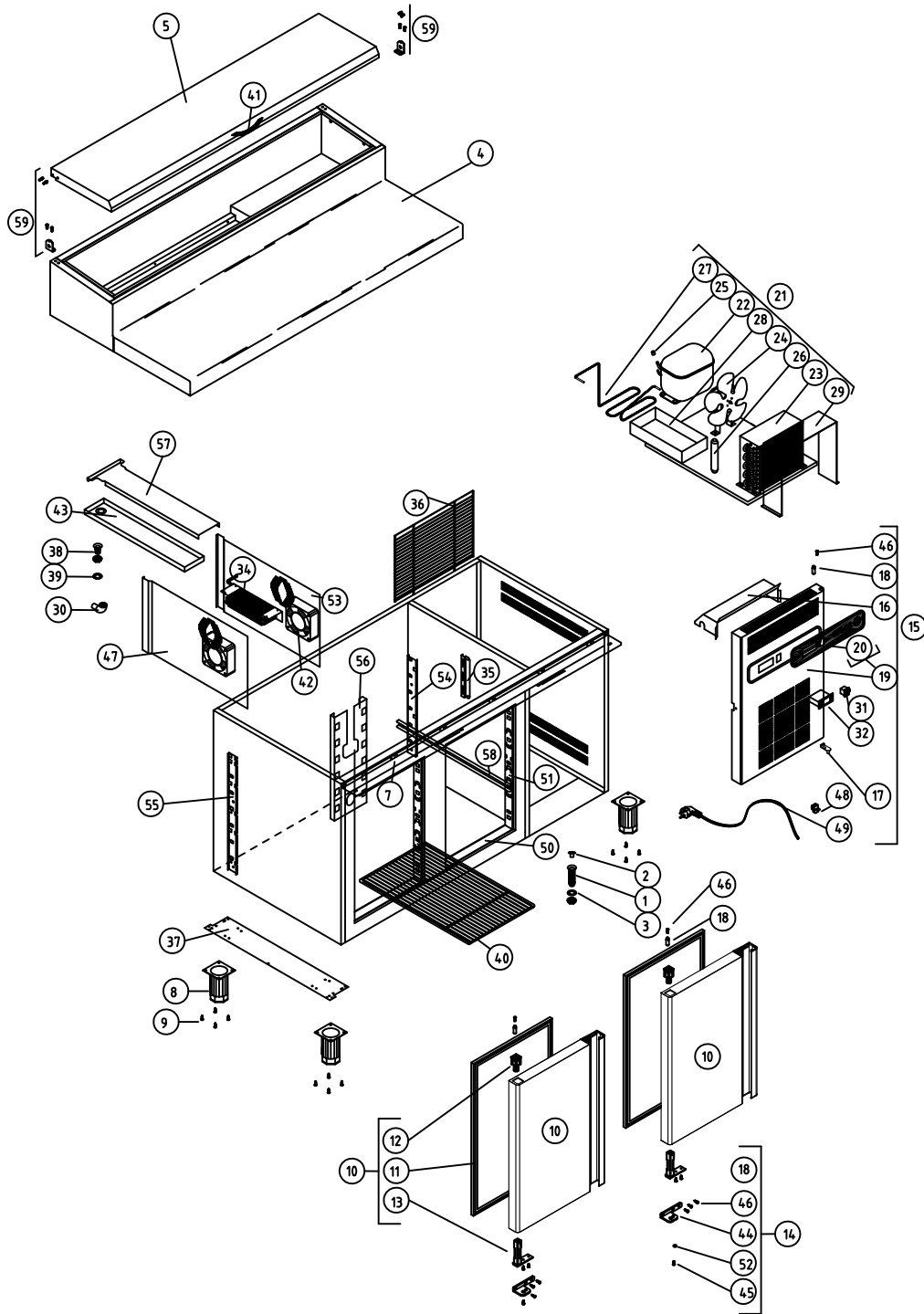

COTAS SIN TOLERANCIA DIN 7168-f				Material:				COD. PIEZA:					
ANGULAR	GRADO TOLERANCIA	FINO	MEDIO	GRUESO	Acabado:				SUSTITUYE A:				
	HASTA 10 mm		±1°	±1° 30'	SUSTITUIDO POR:								
	MAS DE 10 A 50 mm		±30'	±50'	COMUN A	MODELO	Ud.	MODELO	Ud.	MODELO	Ud.	MODIFICACION Nº	RESPONSABLE
	MAS DE 50 A 120 mm		±20'	±25'		MPZ1-150	1					1	B. MORENO
	MAS DE 120 A 400 mm		±10'	±15'									
MAS DE 400 mm		±5'	±10'										
LINEAL	GRADO TOLERANCIA	FINO	MEDIO	GRUESO	FECHA: 8-10-10				 FAGOR <small>F A G O F R I</small>				
	HASTA 3 mm	±0,05	±0,10	±0,15	A4	Nombre		Fecha					
	MAS DE 3 A 6 mm	±0,05	±0,10	±0,20	Dibujado	M.J.GRANADOS		.17-2-09					
	MAS DE 6 A 30 mm	±0,10	±0,20	±0,50	Escala	RECAMBIOS MPZ1-150							
	MAS DE 30 A 120 mm	±0,15	±0,30	±0,80	1:30	DSP.1							
MAS DE 120 A 400 mm	±0,20	±0,50	±1,20					Código máquina:					
MAS DE 400 A 1000 mm	±0,30	±0,80	±2,00					CODIGO					
MAS DE 1000 A 2000 mm	±0,50	±1,20	±3,00										

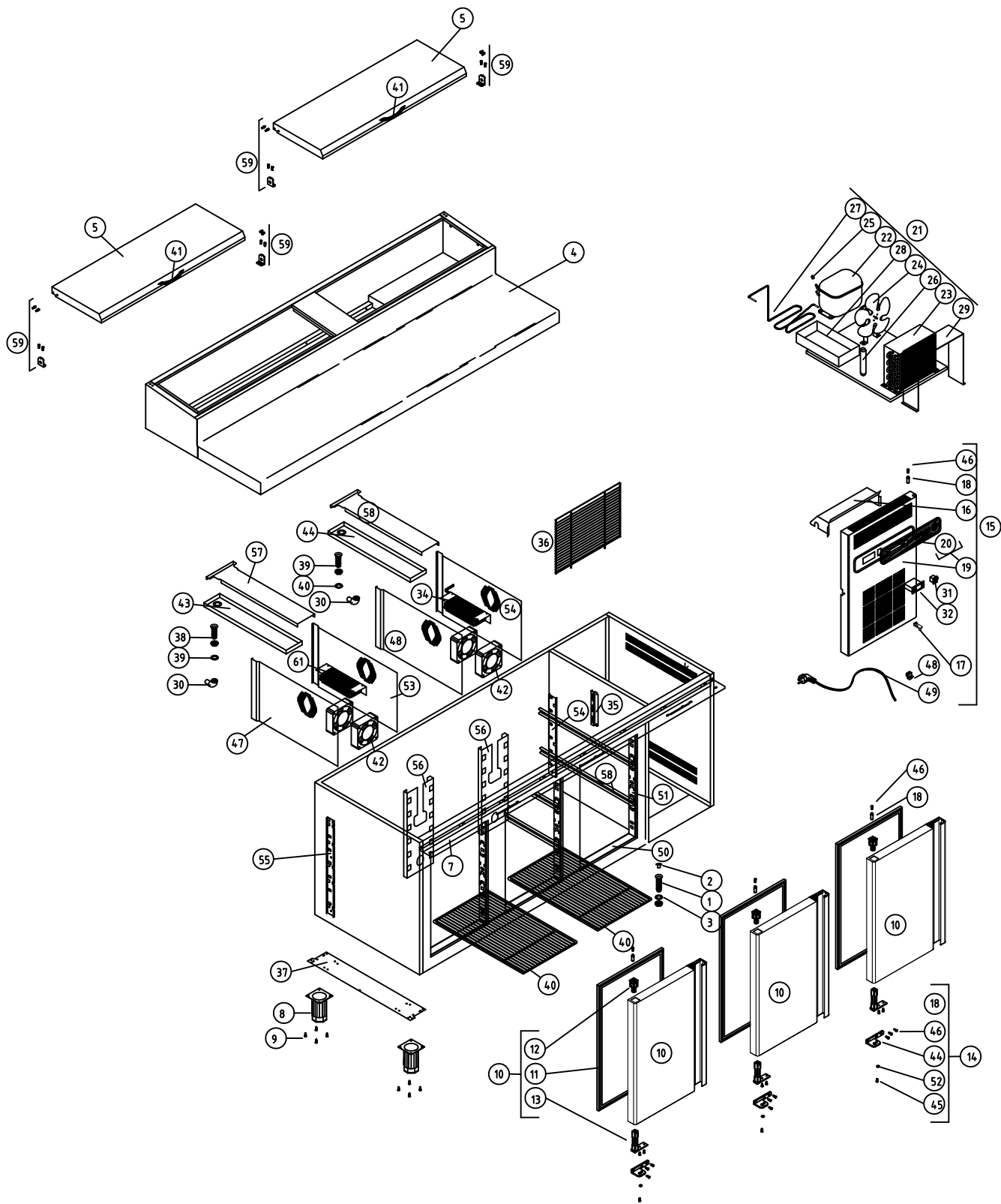

COTAS SIN TOLERANCIA DIN 7168-f				Material:				COD. PIEZA:					
ANGULAR	GRADO TOLERANCIA	FINO	MEDIO	GRUESO	Acabado:				SUSTITUYE A:				
	HASTA 10 mm		±1°	±1° 30'	SUSTITUIDO POR:								
	MÁS DE 10 A 50 mm		±30'	±50'	COMUN A	MODELO	Ud.	MODELO	Ud.	MODELO	Ud.	MODIFICACION Nº	RESPONSABLE
	MÁS DE 50 A 120 mm		±20'	±25'		MPZ1-202	1					1	B. MORENO
	MÁS DE 120 A 400 mm		±10'	±15'									
MÁS DE 400 mm		±5'	±10'										
LINEAL	GRADO TOLERANCIA	FINO	MEDIO	GRUESO	A4				Nombre				
	HASTA 3 mm	±0,05	±0,10	±0,15	Dibujado				M.J.GRANADOS				
	MÁS DE 3 A 6 mm	±0,05	±0,10	±0,20	Escala				1:30				
	MÁS DE 6 A 30 mm	±0,10	±0,20	±0,50	Fecha				.17-2-09				
	MÁS DE 30 A 120 mm	±0,15	±0,30	±0,80	RECAMBIOS MPZ1-202				DSP.2				
MÁS DE 120 A 400 mm	±0,20	±0,50	±1,20	FECHA: 8-10-10				Código máquina:					
MÁS DE 400 A 1000 mm	±0,30	±0,80	±2,00	FAGOR				CODIGO					
MÁS DE 1000 A 2000 mm	±0,50	±1,20	±3,00	F A G O F R I									

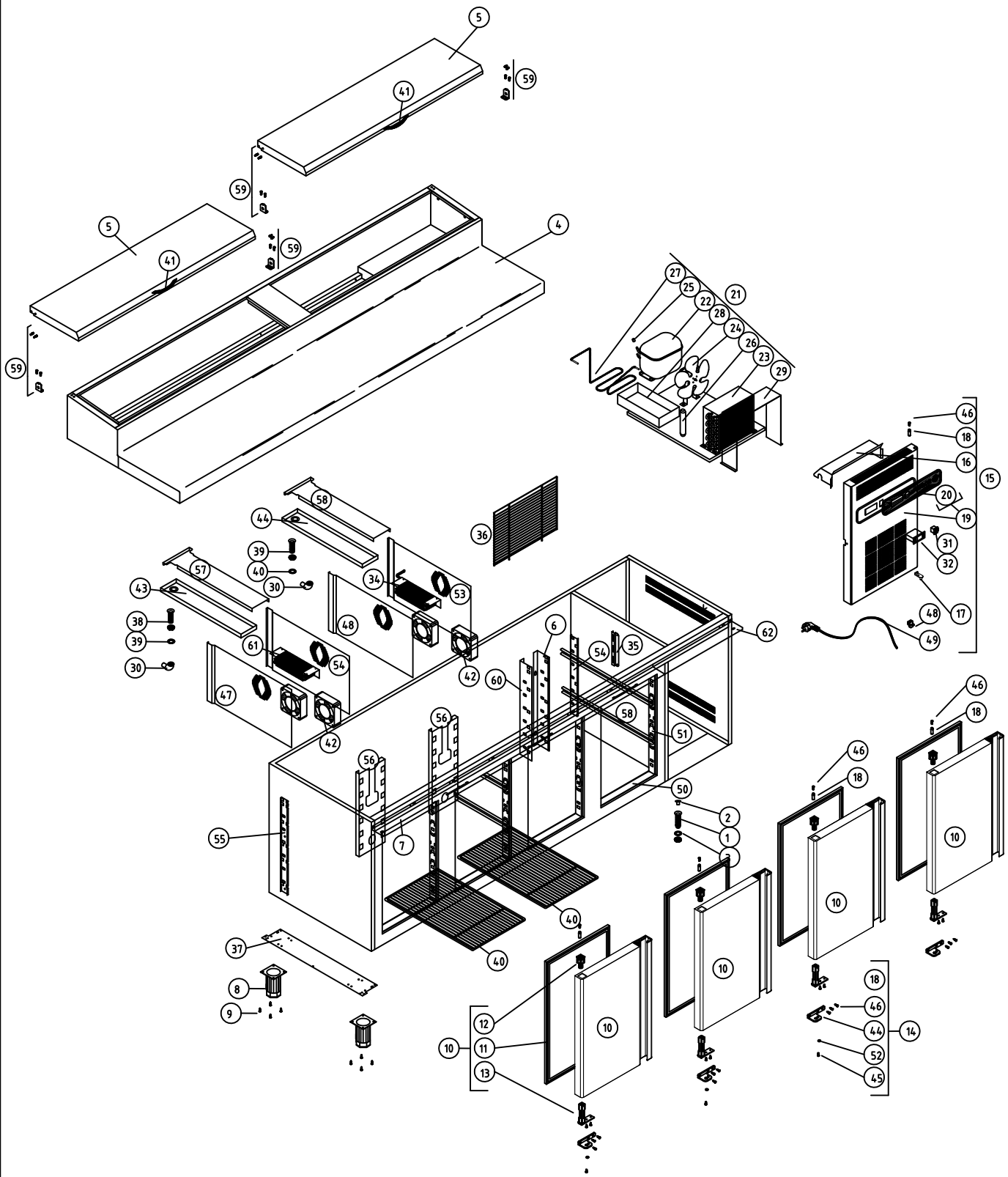

COTAS SIN TOLERANCIA DIN 7168-f				Material:				COD. PIEZA:					
ANGULAR	GRADO TOLERANCIA	FINO	MEDIO	GRUESO	Acabado:				SUSTITUYE A:				
	HASTA 10 mm		±1°	±1° 30'	SUSTITUIDO POR:								
	MÁS DE 10 A 50 mm		±30'	±50'	COMUN A	MODELO	Ud.	MODELO	Ud.	MODELO	Ud.	MODIFICACION Nº	RESPONSABLE
	MÁS DE 50 A 120 mm		±20'	±25'		MPZ1-250	1					1	B. MORENO
	MÁS DE 120 A 400 mm		±10'	±15'									
MÁS DE 400 mm		±5'	±10'								FECHA: 8-10-10		
LINEAL	GRADO TOLERANCIA	FINO	MEDIO	GRUESO	A4	Nombre		Fecha		 F A G O F R I			
	HASTA 3 mm	±0,05	±0,10	±0,15	Dibujado	M.J.GRANADOS		.17-2-09					
	MÁS DE 3 A 6 mm	±0,05	±0,10	±0,20	Escala	RECAMBIOS MPZ1-250 DSP.3		Código máquina: CODIGO					
	MÁS DE 6 A 30 mm	±0,10	±0,20	±0,50									
	MÁS DE 30 A 120 mm	±0,15	±0,30	±0,80									
MÁS DE 120 A 400 mm	±0,20	±0,50	±1,20										
MÁS DE 400 A 1000 mm	±0,30	±0,80	±2,00										
MÁS DE 1000 A 2000 mm	±0,50	±1,20	±3,00										