

DESPIECES

ARMARIOS GASTRO-800



Rev.: Oct-2010

RECAMBIOS
ARMARIOS GASTRO-800
Oct-2010



MODELOS

AFP-801	AFP-802	AF-802-P	AF-802-C	AFN-801	AFN-802	AEP-801	AEP-802	AFP-802/2	AFP-802-2C	AFP-802-3C
---------	---------	----------	----------	---------	---------	---------	---------	-----------	------------	------------

Nº	CÓDIGO	DESCRIPCIÓN	GASTRO											
1	6007050017	PATA REGULABLE ARM.GASTRO	4	4	4	4	4	4	4	4	4	4	4	4
3	6021350021	SONDA CAREL NTC030HP00 3MT	1	1	2	2	1	1	1	1	2	1	1	1
4	A109010460	CABEZA AFP-800 DPTO.			1	1					1			
4	A109010448	CABEZA AFP-800	1	1			1	1	1	1		1	1	1
5	6021130041	MICROR.CONMUT.E3111CA	1	1	1	1	1	1	1	1	1	1	1	1
6	6023010408	PEG.CUAD.FAGOR REFR.347,5X60	1	1			1	1				1	1	
6	6023010406	PEG.CUAD.FAG ARMAR.DPTO			1	1					1			
6	6023010405	PEG.CUAD.FAG REFRIG.ILUM.									1			
7	6021130001	INTERRUPTOR BIPOLAR AMB. ON/OFF	1	1	2	2	1	1	1	1	2	1	1	1
8	6021130002	INTERRUPTOR UNIPOL.LUMINOS.AMB								1	1			
9	6021350018	TERMOS REFRI CAREL PYCO1SN515	1	1	1	1				1	1	2	1	1
11	6029010014	EV.B14T2R426A6S DPTO.PESC PIN.			1									
11	6029010146	BAT.6T4R300A4S PINTADO.ARMARIO	1	1						1	1		1	1
11	6029010160	BATERIA 4T 4R 300A 4S (PINTADO			1	1						2		
11	6029010153	BAT.6T4R 300A 6S.PINT.ARMARIOS				1	1	1						
12	A109250009	SUJ.VENT.AFP-700,800 COMPACTO	1	1	1	2	1	1	1	1	2	1	1	1
13	6021050009	VENTIL. 5WARO 61B ARM DIAM.200												
13	6021050066	VENTIL.EVAPOR.5W S/ARO S/PATAS	1	1	1	2	1	1	1	1	2	1	1	1
14	6027130004	REJILLA VENT.D.246 PINTADA	1	1	1	2	1	1	1	1	2	1	1	1
15	A109250010	CUBRER.EVAP.FC61B ARM.COMPACTO	1	1	1	2	1			1	1	2	1	1
16	6003010033	DESAGÜE 1/2 PULG. CUELLO CORTO				1								
17	6003010175	CODO PVC MIXTO 90° 20x1/2			1									
18	6021010007	COMPRES.FR-8.5-G R134A	1	1						1	1		1	1
18	6021010003	COMPR.TL-5-G R134A			2	1						2		
19	6029020005	CONDENSADOR 10x4 TECHO					1	1						
19	6021050002	CONDENSADOR 9X2	1	1						1	1		1	1
19	6029020008	CONDENSADOR 8X2 REF.C CT82DG			2	1						2		
20	6021050002	VENTILADOR 10W PATA PALA 220V	1	1	2	1	1	1	1	1	1	1	1	1
20	6021050004	VENTIL.5W PATA Y PALA DIAM.200				1						2		
22	6021290052	REGLETA ELECTRONICA 8W	1	1	1	1				1	1	1	1	1
23	6003010184	CANALIZADOR AGUA 150 GRIS REFRIGERACION	1	1	1	1				1	1	2	1	1
24	6003010192	CANALIZADOR AGUA 150 NEGRO MANT.CONGEL.				1	1	1						
25	6033050016	GUIA GN L=662 MM	6	6	2	8	6	6	6	6	4	2	2	2
26	6027010009	PARRILLA GN 2/1 650X530	3	3	1	1	3	3	3	3	2	1	1	1
28	A109050479	CREMALL.INT.AFP-GN	2	2			2	2	2	2				
28	A109050557	CREMALL.INT.DPTO.AF-702-C			2	4					4	2	2	
29	A109050478	CREMALL.DELANT.AFP-GN	2				2		2					
29	A109050561	CREM.DEL.PEQ.AFP-GN DCHA.		4	4	4	4	4	4	4	4	2	2	2
31	A109170174	REJILLA MOTOR 800	1	1	1	1	1	1	1	1	1	1	1	1
32	A169010090	PUE PEQ AFP/AFN IZD		2	2	2	2	2			2	1	1	1
32	A169010081	PUE CAR AFP/AFN IZD	1				1							
33	6045010131	BURLET.1457X636PUERT.CARN.	1				1		1					
33	6045010132	BURLETE PUERT.PEQ.691X636		2	2	2	2	2	2	2	2	1	1	1
35	6033010100	BIS.TRSD DOBL MUELLE DV-2608	1	2	2	2	1	2	1	2	2	1	1	1
37	A161130021	FRONTI HORZ.POST.AFP MAGNETICO		1				1		1		1	1	1
37	A161130023	FRONTI HOR.POST.AF-700,800-C/P			1	1					1			
38	A133010000	SOP.BISAG.DV2607 INF IZQ. FRES		1	1	1	1	1	1	1	1			
39	6033010129	SOP.BISAG.INF.IZD.	1	1	1	1	1	1	1	1	1	1	1	1
40	6033010112	SOP.BISAG.SUP.IZDO.ROSCA M-6	1	1	1	1	1	1	1	1	1	1	1	1
41	6033090104	EJE ROSCA EXT.30X10INOX		1	1	1		1		1	1			
42	6033090064	EJE SUP. PUERTAS 30x10 VARILLA INOX.INT. M-6	1	1	1	1	1	1	1	1	1	1	1	1
43	6003010136	CAJA ALOJAMIENTO MUELLE GRIS	1	2	2	2	1	2	1	2	2	1	1	1
47	6021010001	COMPR.SC-12-CL R404A				1								
47	6021010160	COMPR.NEK-2168-GK 220V50HZ					1	1						
48	6003050006	CUBETA DPTO CONGEL.530X540			3	3								
49	A109050143	FOND. PERF.AGUILAR 530x540x100			3									
51	A109050563	BANDEJA GOTE DPTO.PESCADO			1									
52	A109050562	DUELAS EVAP.DPTO.PESCADO 700/800/2100			1									
53	6021250051	RESIST.DESES.DEP.PESC.220V425W			1									
53	6021250080	RESIST.R17 500W CABLE1MT.				1	1	1						
54	6021250009	RESIST.MARCO EXT.700/800 43W				1	1	1						
55	6021250008	RESIST.FRONTI H.1400-1600 12W				1	1							
56	6033050012	GUIA BAJ GN CENT L=613MM Y PES			6									
57	6021350010	TERM CAREL CONG.PYCO1LO016			1	1	1	1						
58	6021250005	RESIST.BANDEJA 700-20W				1	1	1						
60	6031070067	PUERT. CRIST. AFP IZQD.								1				
61	6031070080	PUERT. CRIST. PEQ.AFP								2				
62	6033010002	TIRADOR ASA CROMADA								1	2			
63	6029020013	CONDENSADOR 10X4 NEUTRO				1								
68	A109050469	BAND.EVAP.AUT.AFP-GN	1	1	1	2	1	1	1	1	2	1	1	1
69	A109170173	TAPA BANDEJA EVAP. AUTOM. AFP.800	1	1	1	2	1	1	1	1	2	1	1	1
70	6021250073	RESIST.EVAP.AUT.80W 3MT	1	1	1	1	1	1	1	1	1	1	1	1
70	6021250078	RESIST.EVAP.AUT.80W 4MT				1					1			
71	6021010035	CONDEN.ARRANQUE SC-117U5017 80 mF				1								
71	6021010036	CONDEN.ARRANQUE TL-G 17U5014 60 mF			2	1					2			
71	6021010037	CONDEN.ARRANQUE FR-117U5015 80 mF	1	1						1	1		1	1
71	6021010165	CONDENSAD ARRANQUE NEK-2168-GK					1	1						
73	6021010042	RELE ARRANQUE COMPRESOR SC-12CL				1								
73	6021010044	RELE ARRANQUE COMPRESOR TL-5G 6000			2	1					2			
73	6021010025	RELE ARRANQUE COMPRESOR FR-8,5G 2	1	1						1	1		1	1
73	6021010166	RELE ARRANQUE NEK-2168-GK					1	1						

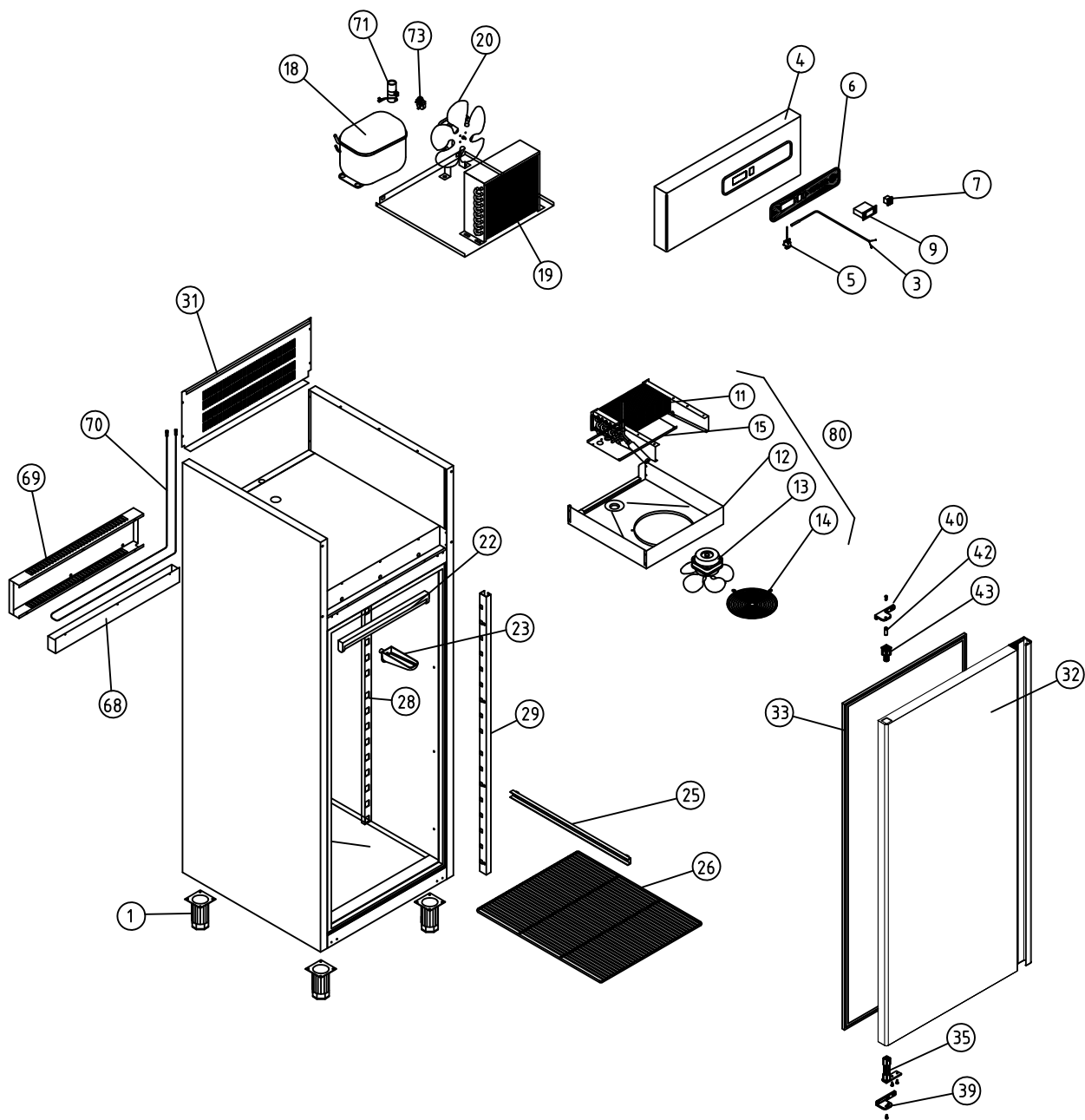

A1 ARMARIOS GASTRONORM

COD. PIEZA: X

COTAS SIN TOLERANCIA DIN 7168-f

Material: MATERIAL ESPESOR

SUSTITUYE A:

ANGULAR	GRADO TOLERANCIA	FINO	MEDIO	GRUESO
	HASTA 10 mm		±1°	
MAS DE 10 A 50 mm		±30'		±50'
MAS DE 50 A 120 mm		±20'		±25'
MAS DE 120 A 400 mm		±10'		±15'
MAS DE 400 mm		±5'		±10'

Acabado: ACABADO

SUSTITUIDO POR:

LINEAL	GRADO TOLERANCIA	FINO	MEDIO	GRUESO
	HASTA 3 mm		±0,05	±0,10
MAS DE 3 A 6 mm		±0,05	±0,10	±0,20
MAS DE 6 A 30 mm		±0,10	±0,20	±0,50
MAS DE 30 A 120 mm		±0,15	±0,30	±0,80
MAS DE 120 A 400 mm		±0,20	±0,50	±1,20
MAS DE 400 A 1000 mm		±0,30	±0,80	±2,00
MAS DE 1000 A 2000 mm		±0,50	±1,20	±3,00

COMUN A	MODELO	Ud.	MODELO	Ud.	MODELO	Ud.	MODELO	Ud.	MODELO	Ud.
		AFP-801	1							

A4	Nombre	Fecha
Dibujado	A.J.GONZALEZ	Oct-2010
Modificado		



Escala	1:30	RECAMBIOS AFP-801	Código máquina: CODIGO
--------	------	-------------------	---------------------------

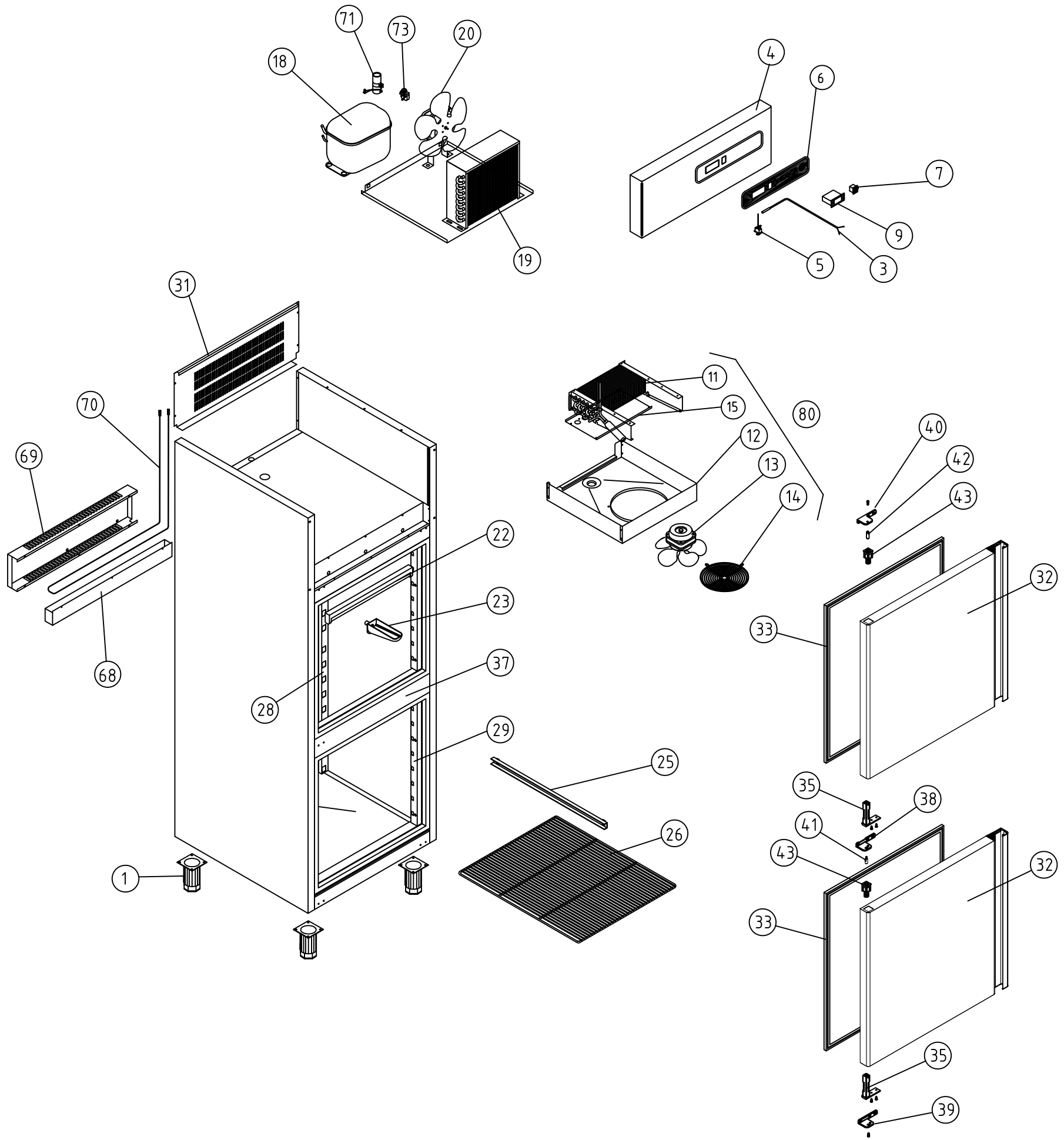

A1 ARMARIOS GASTRONORM COD. PIEZA: X

COTAS SIN TOLERANCIA DIN 7168-f SUSTITUYE A:

Material: MATERIAL ESPESOR SUSTITUIDO POR:

ANGULAR	GRADO TOLERANCIA	FINO	MEDIO	GRUESO	COMUN A	MODELO	Ud.	MODELO	Ud.	MODELO	Ud.	MODELO	Ud.	MODELO
	HASTA 10 mm	±1°		±1° 30'		AFP-802	1							
	MAS DE 10 A 50 mm	±30'		±50'										
	MAS DE 50 A 120 mm	±20'		±25'										
	MAS DE 120 A 400 mm	±10'		±15'										
	MAS DE 400 mm	±5'		±10'										

LINEAL	GRADO TOLERANCIA	FINO	MEDIO	GRUESO	A4	Nombre		Fecha		 Fagofri, s.a.
	HASTA 3 mm	±0,05	±0,10	±0,15		Dibujado	A.J.GONZALEZ		Oct-2010	
	MAS DE 3 A 6 mm	±0,05	±0,10	±0,20	Modificado					
	MAS DE 6 A 30 mm	±0,10	±0,20	±0,50	Escala	RECAMBIOS AFP-802				
	MAS DE 30 A 120 mm	±0,15	±0,30	±0,80	1:30					
	MAS DE 120 A 400 mm	±0,20	±0,50	±1,20						
MAS DE 400 A 1000 mm	±0,30	±0,80	±2,00		Código máquina:					
MAS DE 1000 A 2000 mm	±0,50	±1,20	±3,00		CODIGO					

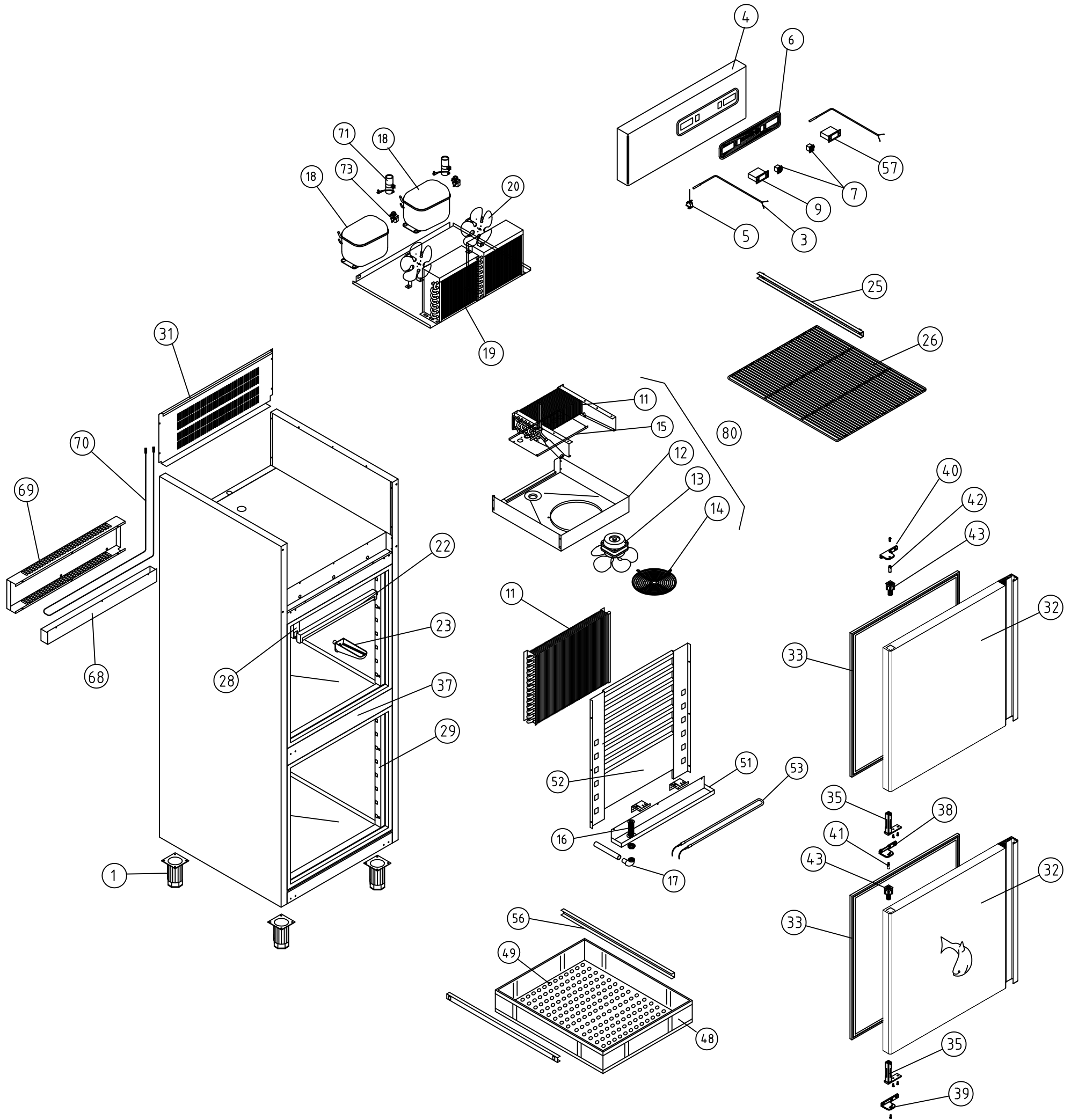

A1 ARMARIOS GASTRONORM DEPARTAMENTO PESCADO COD. PIEZA: X

COTAS SIN TOLERANCIA DIN 7168-f SUSTITUYE A:

Material: MATERIAL ESPESOR SUSTITUIDO POR:

ANGULAR	GRADO TOLERANCIA	FINO	MEDIO	GRUESO	COMUN A	MODELO	Ud.	MODELO	Ud.	MODELO	Ud.	MODELO	Ud.	MODELO
	HASTA 10 mm	±1°		±1° 30'		AF-802-P	1							
	MAS DE 10 A 50 mm	±30'		±50'										
	MAS DE 50 A 120 mm	±20'		±25'										
	MAS DE 120 A 400 mm	±10'		±15'										
MAS DE 400 mm	±5'		±10'											

LINEAL	GRADO TOLERANCIA	FINO	MEDIO	GRUESO	A4	Nombre	Fecha	FAGOR Fagofri, s.a.
	HASTA 3 mm	±0,05	±0,10	±0,15	Dibujado	A.J.GONZALEZ	OCT-2010	
	MAS DE 3 A 6 mm	±0,05	±0,10	±0,20	Modificado			
	MAS DE 6 A 30 mm	±0,10	±0,20	±0,50	Escala	RECAMBIOS AF-802-P		Código máquina:
	MAS DE 30 A 120 mm	±0,15	±0,30	±0,80	1:30			CODIGO
MAS DE 120 A 400 mm	±0,20	±0,50	±1,20					
MAS DE 400 A 1000 mm	±0,30	±0,80	±2,00					
MAS DE 1000 A 2000 mm	±0,50	±1,20	±3,00					

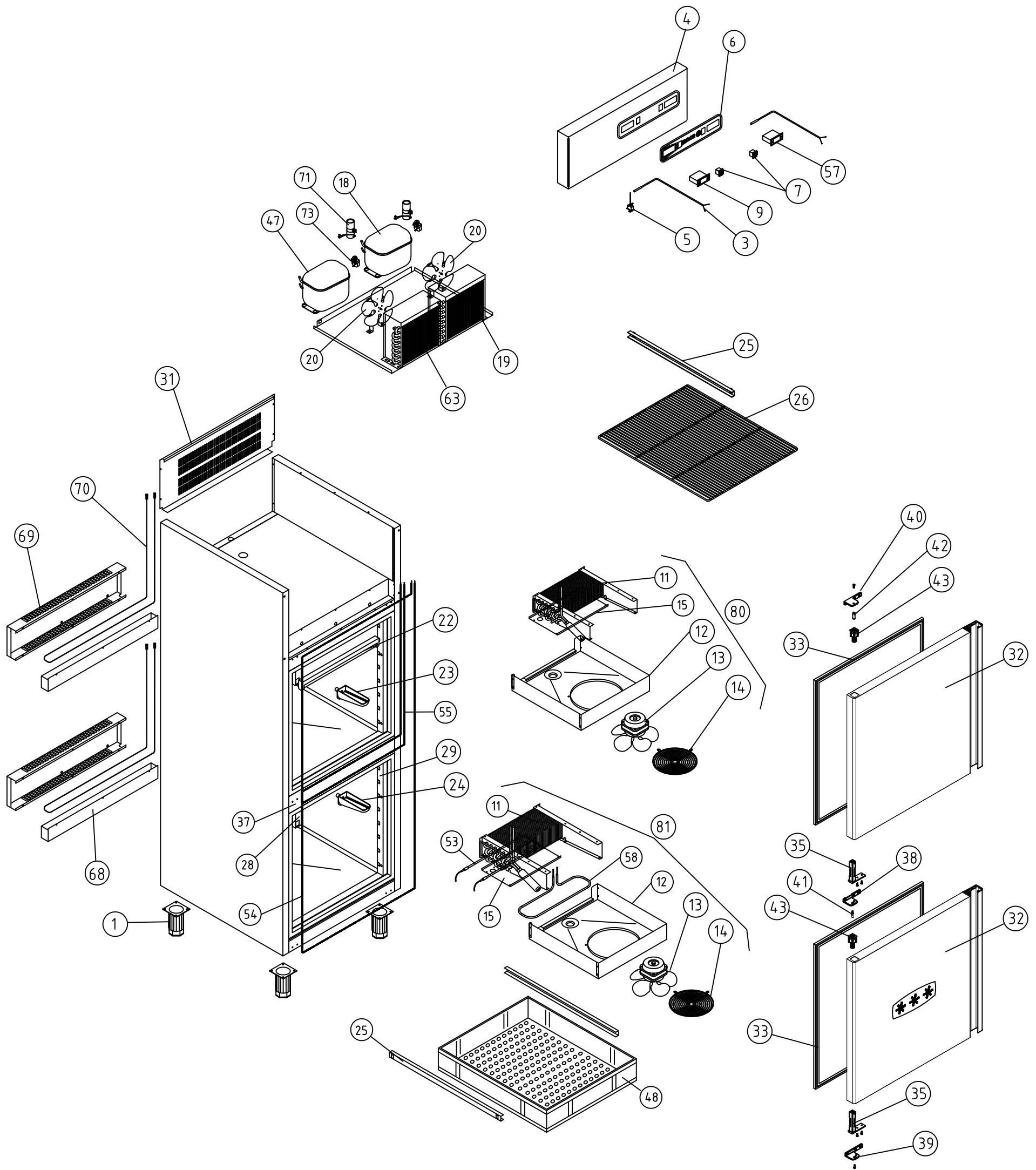

A1 ARMARIOS GASTRONORM DEPARTAMENTO MANTENIMIENTO CONGELADOS COD. PIEZA: X

COTAS SIN TOLERANCIA DIN 7168-f Material: MATERIAL ESPESOR SUSTITUYE A:

Acabado: ACABADO SUSTITUIDO POR:

ANGULAR	GRADO TOLERANCIA	FINO	MEDIO	GRUESO	COMUN A	MODELO	Ud.	MODELO	Ud.	MODELO	Ud.	MODELO	Ud.	MODELO
	HASTA 10 mm		±1°			±1° 30'	AF-802-C	1						
MAS DE 10 A 50 mm		±30'		±50'										
MAS DE 50 A 120 mm		±20'		±25'										
MAS DE 120 A 400 mm		±10'		±15'										
MAS DE 400 mm		±5'		±10'										

LINEAL	GRADO TOLERANCIA	FINO	MEDIO	GRUESO	A4	Nombre	Fecha	 Fagofri, s.a.
	HASTA 3 mm		±0,05	±0,10	±0,15	Dibujado	A.J.GONZALEZ	
MAS DE 3 A 6 mm		±0,05	±0,10	±0,20	Modificado			
MAS DE 6 A 30 mm		±0,10	±0,20	±0,50	Escala			
MAS DE 30 A 120 mm		±0,15	±0,30	±0,80	1:30			
MAS DE 120 A 400 mm		±0,20	±0,50	±1,20				
MAS DE 400 A 1000 mm		±0,30	±0,80	±2,00				
MAS DE 1000 A 2000 mm		±0,50	±1,20	±3,00				

RECAMBIOS AF-802-C

Código máquina:
CODIGO

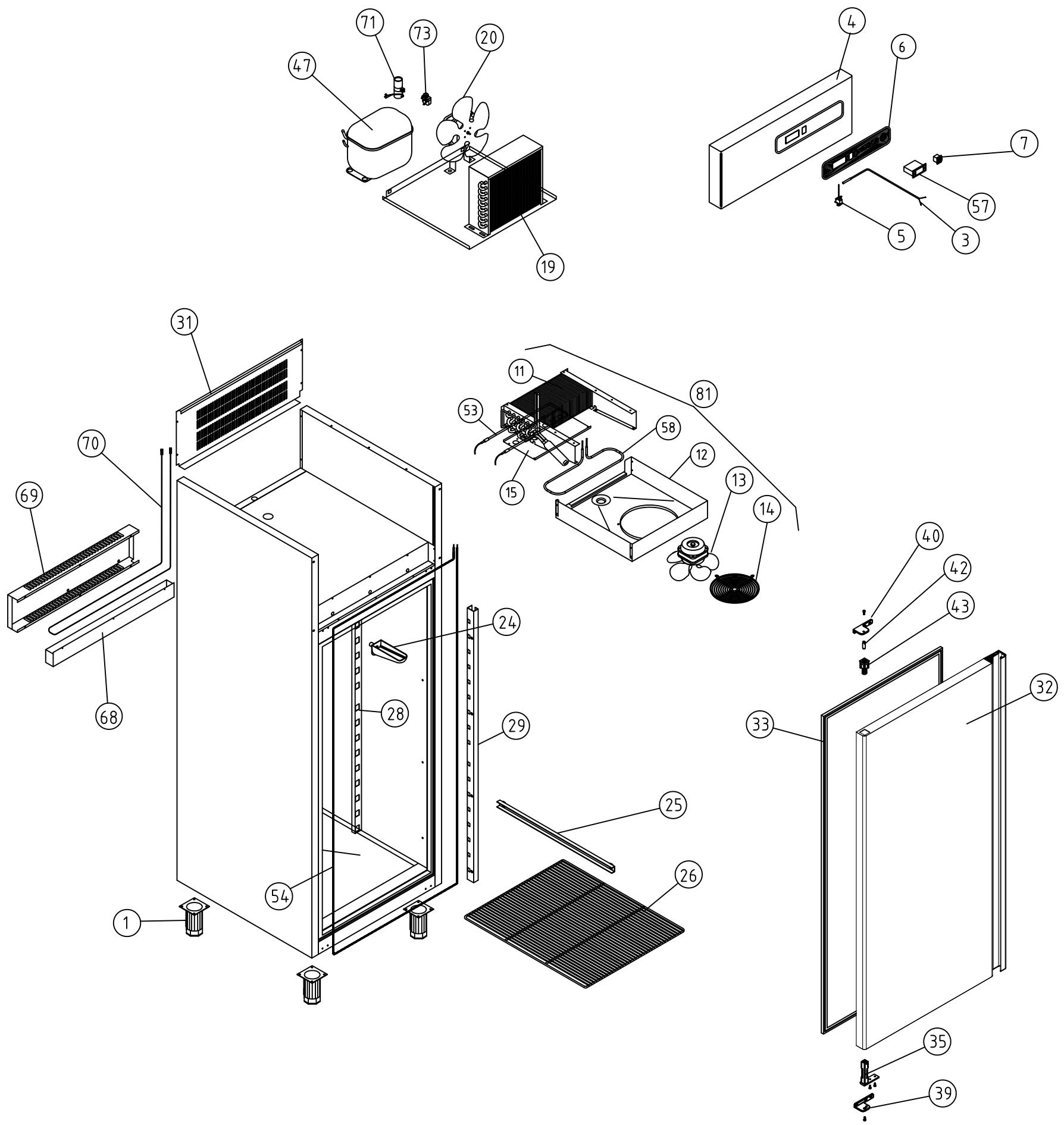

A1 ARMARIOS GASTRONORM MANTENIMIENTO CONGELADOS COD. PIEZA: X

COTAS SIN TOLERANCIA DIN 7168-f Material: MATERIAL ESPESOR SUSTITUYE A:

Acabado: ACABADO SUSTITUIDO POR:

ANGULAR	GRADO TOLERANCIA	FINO	MEDIO	GRUESO	COMUN A	MODELO	Ud.	MODELO	Ud.	MODELO	Ud.	MODELO	Ud.	MODELO
	HASTA 10 mm		±1°			±1° 30'	AFN-801	1						
MAS DE 10 A 50 mm		±30'		±50'										
MAS DE 50 A 120 mm		±20'		±25'										
MAS DE 120 A 400 mm		±10'		±15'										
MAS DE 400 mm		±5'		±10'										

LINEAL	GRADO TOLERANCIA	FINO	MEDIO	GRUESO	A4	Nombre	Fecha	 Fagofri, s.a.
	HASTA 3 mm		±0,05	±0,10	±0,15	Dibujado	A.J.GONZALEZ	
MAS DE 3 A 6 mm		±0,05	±0,10	±0,20	Modificado			
MAS DE 6 A 30 mm		±0,10	±0,20	±0,50	Escala			
MAS DE 30 A 120 mm		±0,15	±0,30	±0,80	1:30			
MAS DE 120 A 400 mm		±0,20	±0,50	±1,20				
MAS DE 400 A 1000 mm		±0,30	±0,80	±2,00				
MAS DE 1000 A 2000 mm		±0,50	±1,20	±3,00				

RECAMBIOS AFN-801

Código máquina:
CODIGO

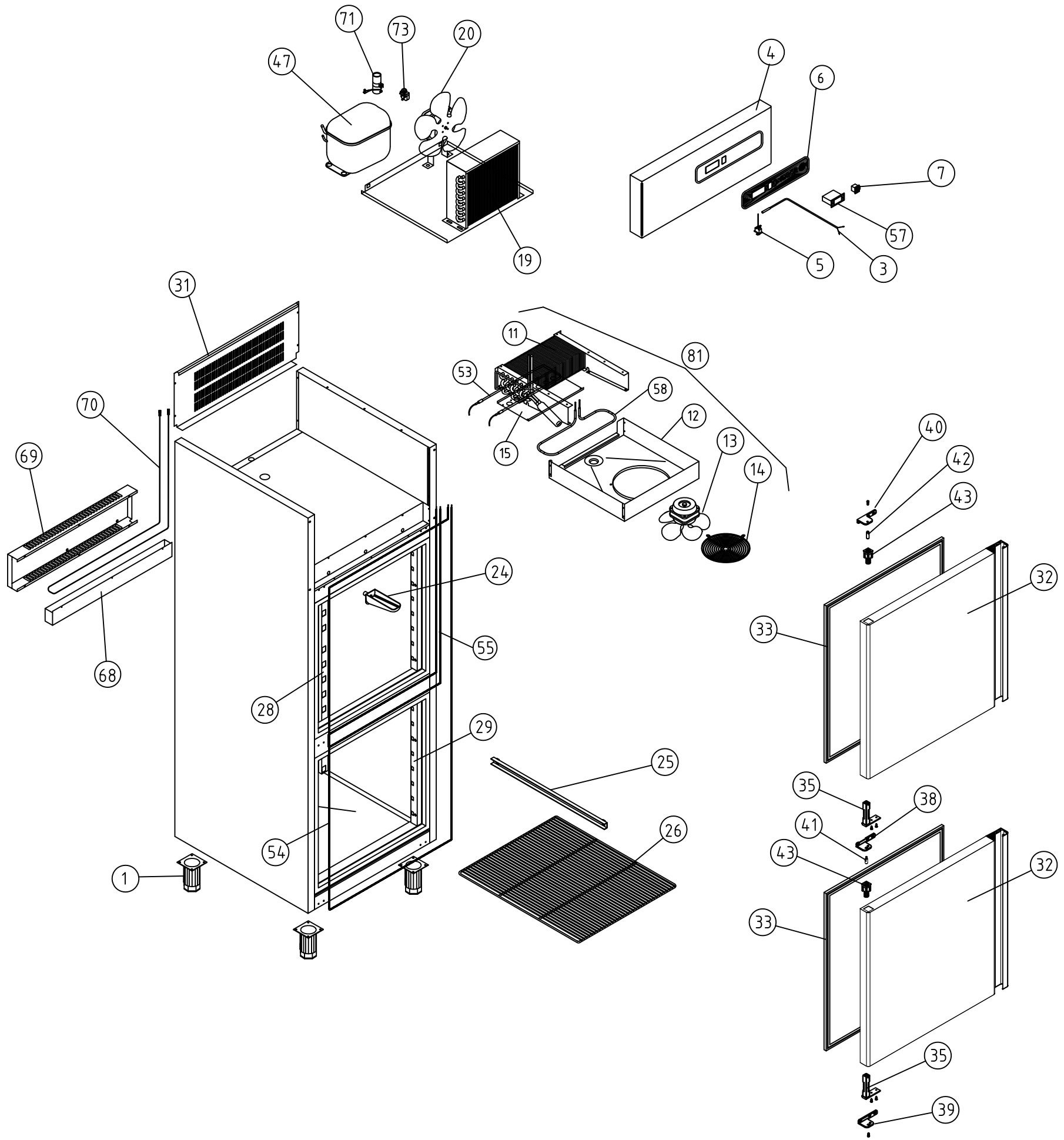

A1 ARMARIOS GASTRONORM MANTENIMIENTO CONGELADOS COD. PIEZA: X

COTAS SIN TOLERANCIA DIN 7168-f SUSTITUYE A:

Material: MATERIAL ESPESOR SUSTITUIDO POR:

ANGULAR	GRADO TOLERANCIA	FINO	MEDIO	GRUESO	COMUN A	MODELO	Ud.	MODELO	Ud.	MODELO	Ud.	MODELO	Ud.	MODELO
	HASTA 10 mm	±1°		±1° 30'		AFN-802	1							
	MAS DE 10 A 50 mm	±30'		±50'										
	MAS DE 50 A 120 mm	±20'		±25'										
	MAS DE 120	±10'		±15'										

	Nombre A.J.GONZALEZ	Fecha Oct-2010	FAGOR Fagofri, s.a.
--	------------------------	-------------------	-------------------------------

1:30	RECAMBIOS AFN-802	Código máquina: CODIGO
------	-------------------	---------------------------

A 1000 mm	±0,30	±0,80	±2,00
MAS DE 1000 A 2000 mm	±0,50	±1,20	±3,00

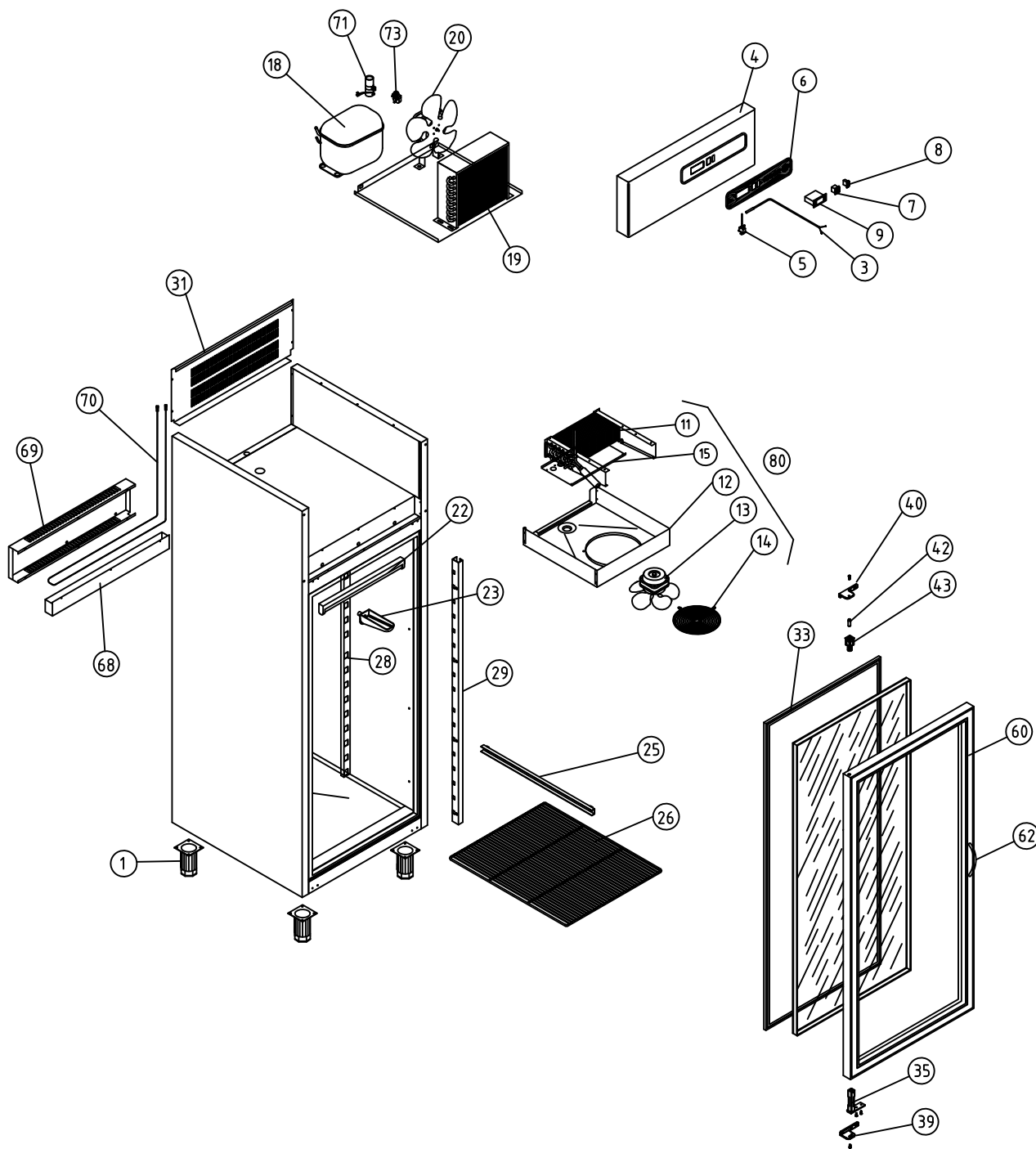

A1 ARMARIOS GASTRONORM

COD. PIEZA: X

COTAS SIN TOLERANCIA DIN 7168-f

Material: MATERIAL ESPESOR

SUSTITUYE A:

GRADO TOLERANCIA	FINO	MEDIO	GRUESO
HASTA 10 mm	±1°		±1° 30'
MAS DE 10 A 50 mm	±30'		±50'
MAS DE 50 A 120 mm	±20'		±25'
MAS DE 120 A 400 mm	±10'		±15'
MAS DE 400 mm	±5'		±10'

Acabado: ACABADO

SUSTITUIDO POR:

GRADO TOLERANCIA	FINO	MEDIO	GRUESO
HASTA 3 mm	±0,05	±0,10	±0,15
MAS DE 3 A 6 mm	±0,05	±0,10	±0,20
MAS DE 6 A 30 mm	±0,10	±0,20	±0,50
MAS DE 30 A 120 mm	±0,15	±0,30	±0,80
MAS DE 120 A 400 mm	±0,20	±0,50	±1,20
MAS DE 400 A 1000 mm	±0,30	±0,80	±2,00
MAS DE 1000 A 2000 mm	±0,50	±1,20	±3,00

COMUN A	MODELO	Ud.	MODELO	Ud.	MODELO	Ud.	MODELO	Ud.	MODELO	Ud.	MODELO
	AEP-801	1									

A4	Nombre	Fecha
Dibujado	A.J.GONZALEZ	Oct-2010
Modificado		



Escala	1:30	RECAMBIOS AEP-801	Código máquina: CODIGO
--------	------	-------------------	---------------------------

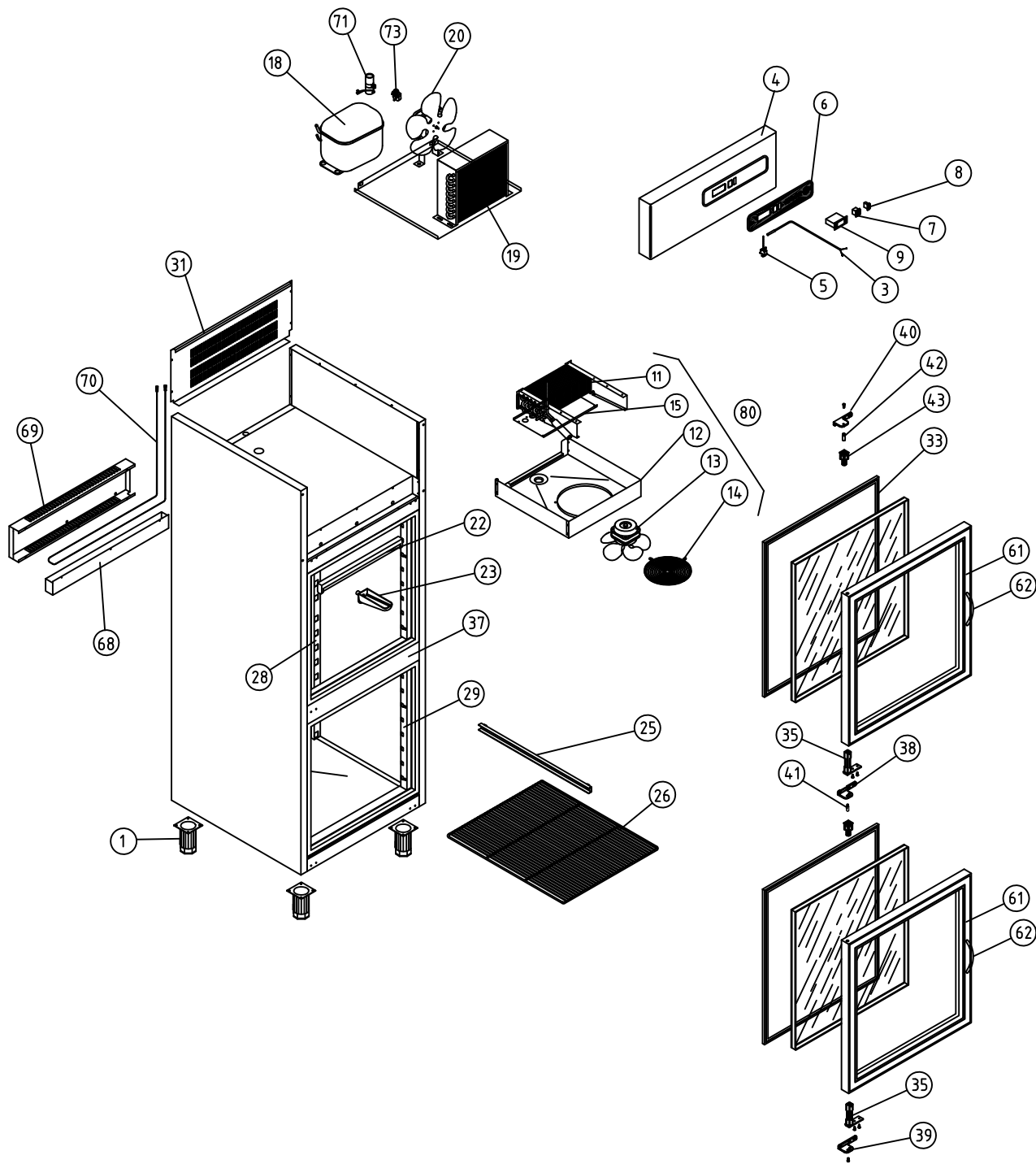

A1 ARMARIOS GASTRONORM

COD. PIEZA: X

COTAS SIN TOLERANCIA DIN 7168-f

Material: MATERIAL ESPESOR

SUSTITUYE A:

GRADO TOLERANCIA	FINO	MEDIO	GRUESO
HASTA 10 mm	±1'		±1' 30'
MAS DE 10 A 50 mm	±30'		±50'
MAS DE 50 A 120 mm	±20'		±25'
MAS DE 120 A 400 mm	±10'		±15'
MAS DE 400 mm	±5'		±10'

Acabado: ACABADO

SUSTITUIDO POR:

GRADO TOLERANCIA	FINO	MEDIO	GRUESO
HASTA 3 mm	±0,05	±0,10	±0,15
MAS DE 3 A 6 mm	±0,05	±0,10	±0,20
MAS DE 6 A 30 mm	±0,10	±0,20	±0,50
MAS DE 30 A 120 mm	±0,15	±0,30	±0,80
MAS DE 120 A 400 mm	±0,20	±0,50	±1,20
MAS DE 400 A 1000 mm	±0,30	±0,80	±2,00
MAS DE 1000 A 2000 mm	±0,50	±1,20	±3,00

COMUN A	MODELO	Ud.	MODELO	Ud.	MODELO	Ud.	MODELO	Ud.	MODELO	Ud.
	AEP-802	1								

GRADO TOLERANCIA	FINO	MEDIO	GRUESO
HASTA 3 mm	±0,05	±0,10	±0,15
MAS DE 3 A 6 mm	±0,05	±0,10	±0,20
MAS DE 6 A 30 mm	±0,10	±0,20	±0,50
MAS DE 30 A 120 mm	±0,15	±0,30	±0,80
MAS DE 120 A 400 mm	±0,20	±0,50	±1,20
MAS DE 400 A 1000 mm	±0,30	±0,80	±2,00
MAS DE 1000 A 2000 mm	±0,50	±1,20	±3,00

A4	Nombre	Fecha
Dibujado	A.J.GONZALEZ	Oct-2010
Modificado		
Escala	1:30	



RECAMBIOS AEP-802

Código máquina:
CODIGO

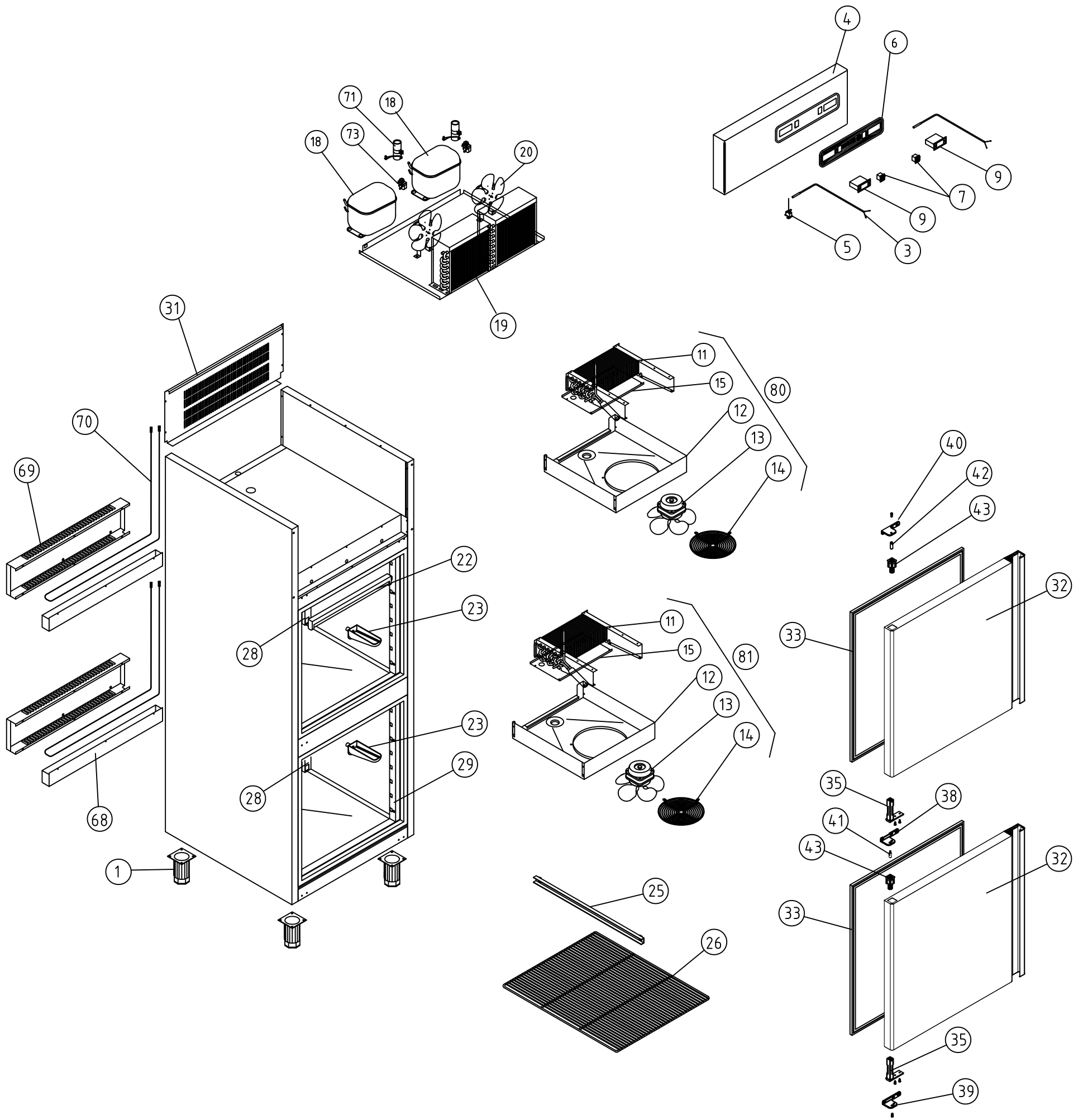

A1 ARMARIOS GASTRONORM DEPARTAMENTO MANTENIMIENTO CONGELADOS COD. PIEZA: X

COTAS SIN TOLERANCIA DIN 7168-f Material: MATERIAL ESPESOR SUSTITUYE A:

Acabado: ACABADO SUSTITUIDO POR:

ANGULAR	GRADO TOLERANCIA	FINO	MEDIO	GRUESO	COMUN A	MODELO	Ud.	MODELO	Ud.	MODELO	Ud.	MODELO	Ud.	MODELO
	HASTA 10 mm		±1°			±1° 30'	AF-802-2	1						
MAS DE 10 A 50 mm		±30'		±50'										
MAS DE 50 A 120 mm		±20'		±25'										
MAS DE 120 A 400 mm		±10'		±15'										
MAS DE 400 mm		±5'		±10'										

LINEAL	GRADO TOLERANCIA	FINO	MEDIO	GRUESO	A4	Nombre	Fecha	 Fagofri, s.a.
	HASTA 3 mm		±0,05	±0,10	±0,15	Dibujado	A.J.GONZALEZ	
MAS DE 3 A 6 mm		±0,05	±0,10	±0,20	Modificado			
MAS DE 6 A 30 mm		±0,10	±0,20	±0,50	Escala			
MAS DE 30 A 120 mm		±0,15	±0,30	±0,80	1:30			
MAS DE 120 A 400 mm		±0,20	±0,50	±1,20				
MAS DE 400 A 1000 mm		±0,30	±0,80	±2,00				
MAS DE 1000 A 2000 mm		±0,50	±1,20	±3,00				

RECAMBIOS AFP-802/2

Código máquina:
CODIGO

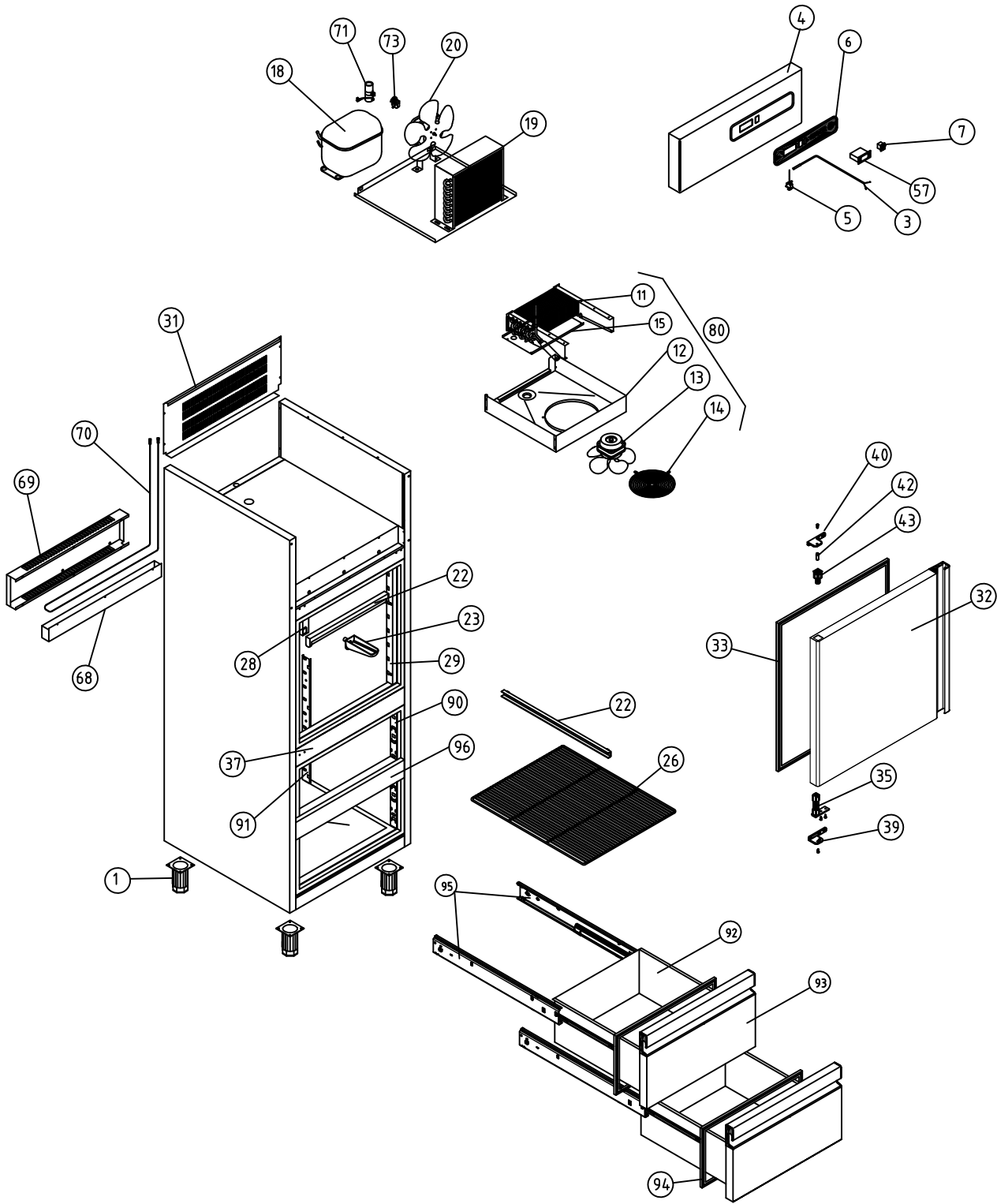

A1 ARMARIOS GASTRONORM DEPARTAMENTO MANTENIMIENTO CONGELADOS

COD. PIEZA: X

COTAS SIN TOLERANCIA DIN 7168-f

Material: MATERIAL ESPESOR

SUSTITUYE A:

Acabado: ACABADO

SUSTITUIDO POR:

ANGULAR	GRADO TOLERANCIA	FINO	MEDIO	GRUESO
	HASTA 10 mm		±1°	±1° 30'
	MAS DE 10 A 50 mm	±30'		±50'
	MAS DE 50 A 120 mm	±20'		±25'

COMUN A	MODELO	Ud.	MODELO	Ud.	MODELO	Ud.	MODELO	Ud.	MODELO	Ud.
	AF-802 2C	1								

LINEAL	GRADO TOLERANCIA	FINO	MEDIO	GRUESO
	HASTA 3 mm	±0,05	±0,10	±0,15
	MAS DE 3 A 6 mm	±0,05	±0,10	±0,20
	MAS DE 6 A 30 mm	±0,10	±0,20	±0,50
	MAS DE 30 A 120 mm	±0,15	±0,30	±0,80

A4	Nombre	Fecha
Dibujado	A.J.GONZALEZ	Oct-2010
Modificado		



Escala	1:30
--------	------

RECAMBIOS AFP-802 2C

Código máquina:
CODIGO

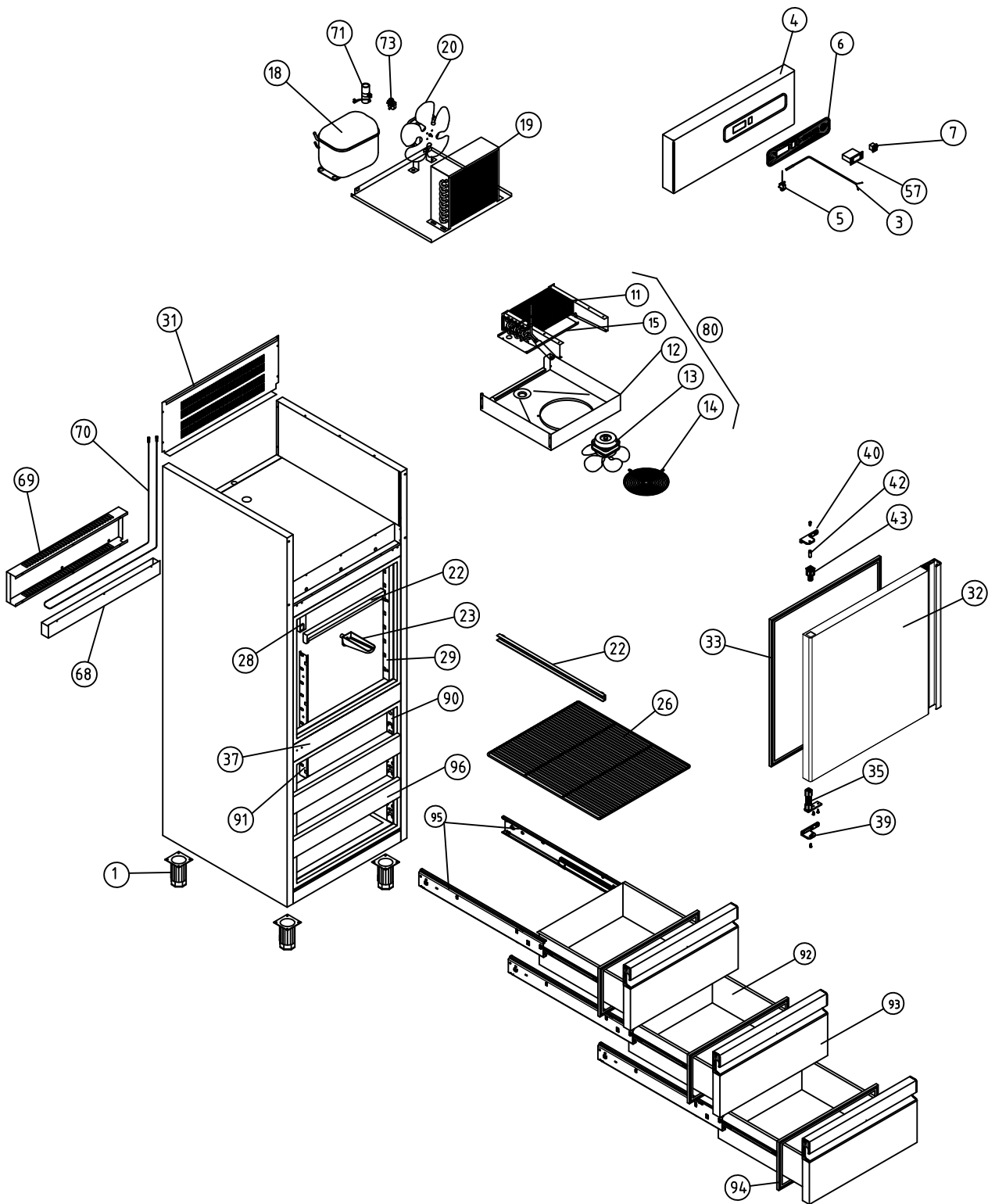

A1 ARMARIOS GASTRONORM DEPARTAMENTO MANTENIMIENTO CONGELADOS COD. PIEZA: X

COTAS SIN TOLERANCIA DIN 7168-f Material: MATERIAL ESPESOR SUSTITUYE A:

Acabado: ACABADO SUSTITUIDO POR:

ANGULAR	GRADO TOLERANCIA	FINO	MEDIO	GRUESO	COMUN A	MODELO	Ud.	MODELO	Ud.	MODELO	Ud.	MODELO	Ud.	MODELO
	HASTA 10 mm		±1°			±1° 30'	AF-802 3C	1						
MAS DE 10 A 50 mm		±30'		±50'										
MAS DE 50 A 120 mm		±20'		±25'										
MAS DE 120 A 400 mm		±10'		±15'										
MAS DE 400 mm		±5'		±10'										

LINEAL	GRADO TOLERANCIA	FINO	MEDIO	GRUESO	A4	Nombre	Fecha	 Fagofri, s.a.
	HASTA 3 mm		±0,05	±0,10		±0,15	Dibujado	
MAS DE 3 A 6 mm		±0,05	±0,10	±0,20	Modificado			
MAS DE 6 A 30 mm		±0,10	±0,20	±0,50	Escala			
MAS DE 30 A 120 mm		±0,15	±0,30	±0,80				
MAS DE 120 A 400 mm		±0,20	±0,50	±1,20				
MAS DE 400 A 1000 mm		±0,30	±0,80	±2,00				
MAS DE 1000 A 2000 mm		±0,50	±1,20	±3,00				

RECAMBIOS AFP-802 3C

Código máquina:
CODIGO