

# ***DESPIECES ARMARIOS***

## ***SNACK-2100***



*Rev.: Oct-2012*

**RECAMBIOS**  
ARMARIOS SNACK-2100  
Octubre-2012



MODELOS

	AFP-2103	AFP-2104	AFP-2105	AFP-2106	AF-2104-P	AF-2105-P	AF-2106-P	AF-2104-C	AF-2105-C	AF-2106-C	AEP-2103																						
<b>Nº</b>	<b>CÓDIGO</b>											<b>DESCRIPCIÓN</b>											<b>SNACK</b>										
1	6007050017	PATA REGULABLE ARM.GASTRO											6	6	6	6	6	6	6	6	6	6	6	6									
3	6021350113	SONDA NTC 2,5 MTS											1	1	1	1	1	2	2	2	2	2	2	1									
4	A109010839	CABEZA AFP-2100											1	1	1	1								1									
4	A109010906	CABEZA AF-2100 DPTO																1	1	1	1	1	1										
5	6021130041	MICROR.CONMUT.E3111CA											3	3	3	3	3	3	3	3	3	3	3	3									
6	6023010553	PEG.FAGOR GAMA CONCEPT											1	1										1									
6	6023010554	PEG. FAGOR GAMA CONCEPT DPTO																1	1	1	1	1	1										
7	6021130065	INTERRUPTOR BIP. O/I NEGRO/ROJO											1	1	1	1	2	2	2	2	2	2	2	1									
8	6021130066	INTERRUPTOR UNIPOL. NEGRO/ROJO																						1									
9	A177090018	CONJ.TERM. REF. 220v 50Hz											1	1	1	1	1	1	1	1	1	1	1	1									
10	A109250012	SOP.CARC.VENTIL.AFP-1400 COMP.											1	1	1	1	1	1	1	1	1	1	1	1									
11	6029010014	EV.B14T2R426A6S DPTO.PESC PIN.																1	1	1													
11	6029010149	2XBAT.4T6R350A6S PINT.AFN1400											1	1	1	1	1	1	1	1	1	1	1	1									
11	6029010144	EV.COMP.FC-61B AR.C/T CONG IZD																			1	1	1										
12	A109250011	SUJ.VENT.AFP-1400,1600 COMPACT											1	1	1	1	1	1	1	1	1	1	1	1									
13	6021050067	VENT.EVAP.10W S/ARO S/PATAS											1	1	1	1	1	1	1	1	1	1	1	1									
14	6027130005	REJILLA VENT.D297 PINTADA											1	1	1	1	1	1	1	1	1	1	1	1									
15	A109250014	CUBRER.2BAT4T6R350A 6S AFN1400											2	2	2	2	2	2	2	2	2	2	2	2									
16	6003010033	DESAGÜE 1/2 PULG. CUELLO CORTO																1	1	1													
17	6003010175	CODO PVC MIXTO 90° 20x1/2																1	1	1													
18	6021010161	COMPR.NEK-6214-Z 220V 50HZ											1	1	1	1	1	1	1	1	1	1	1	1									
19	6029020005	CONDENSADOR 10x4 TECHO											1	1	1	1	1	1	1	1	1	1	1	1									
20	6021050002	VENTILADOR 10W PATA PALA 220V											1	1	1	1	1	1	1	2	2	2	2	1									
21	6003010023	BANDEJA EVAPORACION AUTOMÁTICA											1	1	1	1				2	2	2	2	1									
22	6021290057	REGLETA ELECTRONICA 21W T5											2	2	2	2	2	2	2	2	2	2	2	2									
23	6003010184	CANALIZADOR AGUA 150 GRIS REFRIGERACION											1	1	1	1	1	1	1	1	1	1	1	1									
24	6003010192	CANALIZADOR AGUA 150 NEGRO MANT.CONGEL.																		1	1	1	1										
26	6027010087	PARRILLA 560X542 AR.SNACK											9	9	9	9	7	7	7	7	7	7	7	9									
27	6027010086	PARRILL.500X158SUPL.SNACK											2	2	2	2	1	1	1	1	1	1	1	2									
27	6027010089	PARRILLA 455x154 SUPL.1400 LUZ											4	4	4	4	3	3	3	3	3	3	3	4									
28	A109050445	CREMALL.INT.AFP-SNACK											6	6	6	6	4	4	4	4	4	4	4	6									
29	A109050557	CREMALL.INT.DPTO.AF-702-C																			2	2	2										
29	A109050559	CREMAL.INT.PEQ.EXT.DPTO																2	2	2	2	2	2										
29	A109050443	CREMALL.DEL.DCH.AFP-SNACK											3	2	1			2	1		2	1		3									
29	A109050444	CREMAL.DEL.IZD.AFP-SNACK											3	2	1			2	1		2	1		3									
29	A109050493	CREM.DELANT.DCH.PEQ.AFP												2	4	6	1	3	5	1	3	5											
29	A109050494	CREM.DELANT.IZD.PEQ.AFP												2	4	6	1	3	5	1	3	5											
29	A109050769	CREM. DCHA. DPTO PESCADO 2100															1	1	1	1	1	1	1										
29	A109050768	CREM. IZDA DPTO. PESCADO 2100															1	1	1	1	1	1	1										
31	A109010859	REJILLA GRUPO AFP-2100											1	1	1	1	1	1	1	1	1	1	1	1									
32	A169010190	PUE PEQ AFP/AFN CONCEPT IZD													2	4		2	4		2	4											
32	A169010191	PUE PEQ AFP/AFN CONCEPT DCHA												2	2	2	2	2	2	2	2	2	2										
32	A169010188	PUE CARN AFP/AFN CONCEPT IZD											2	2	1			2	1		2	1											
32	A169010189	PUE CARN AFP/AFN CONCEPT DCHA											1																				
33	6045010131	BURLET.1457X636PUERT.CARN.											3	2	1			2	1		2	1		3									
33	6045010132	BURLETE PUERT.PEQ.691X636												2	4	6	2	4	6	2	4	6											
35	6033010100	BIS.TRS1D DOBL MUELLE DV-2608											3	4	5	6	4	5	6	4	5	6	3										
37	A161130021	FRONTI HORZ.POST.AFP MAGNETICO												1	2	3		1	2		1	2											
38	A133010001	SOP.BISAG.DV2606 INF DCH. FRES												1	1	1	1	1	1	1	1	1	1										
39	6033010130	SOP.BISAG.INF.DCH.											1	1	1	1	1	1	1	1	1	1	1	1									
40	6033010140	SOPORTE SUPERIOR BISAGRA DERECHO											1	1	1	1	1	1	1	1	1	1	1	1									
41	A133010000	SOP.BISAG.DV2607 INF IZQ. FRES														1	2		1	2		1	2										
42	6033010129	SOP.BISAG.INF.IZD.											2	2	2	2	2	2	2	2	2	2	2	2									
43	6033010141	SOPORTE SUPERIOR BISAGRA IZQUIERDO											2	2	2	2	2	2	2	2	2	2	2	2									
44	6033090104	EJE ROSCA EXT.30X10INOX												1	2	3	1	2	3	1	2	3											
45	6033090064	EJE30x10VARIL INOX ROSC.INT M6											3	3	3	3	3	3	3	3	3	3	3	3									
46	6003010136	CAJA ALOJAMIENTO MUELLE GRIS											3	4	5	6	4	5	6	4	5	6	3										
47	6021010003	COMPR.TL-5-G R134A																1	1	1													
47	6021010001	COMPR.SC-12-CL R404A																			1	1	1										
48	6003050006	CUBETA DPTO CONGEL.530X540																			3	3	3										
48	6003050007	CUBETA DPTO PESCADO 530X460																3	3	3													
49	A109050103	FOND.PERF.CUB.DPTO.530X460 AFP-SNACK																3	3	3													
51	A109050563	BANDEJ.GOTEO AF-DPTO PESC.																1	1	1													
52	A109050562	DUELAS EVAP.DPTO.PESCADO 700/800/2100																1	1	1													
53	6021250051	RESIST.DESES.DEP.PESC.220V425W																1	1	1													
54	6021250014	RESIST.MARCO PUERTA INF.28W																			1	1	1										
56	6033050015	GUIA SNACK DPTO CONGEL.562mm																			6	6	6										
56	6033050010	GUIA SNACK DPTO.PESCADO 519mm																6	6	6													
57	A177090020	CONJ. TERM.CONG. 220v 50Hz																1	1	1	1	1	1										
58	6021250011	RESIST.BANDEJA DEPART.18W																			1	1	1										
60	6031070091	PT. CRISTAL ARM 684x1505																						3									
62	6033010135	TIRAD. PT. CRISTAL																						3									
63	6029020013	CONDENSADOR 10X4 NEUTRO																			1	1	1										
63	6029020008	CONDENSADOR 8X2 REF.C CT82DG																1	1	1													
64	6021050004	VENTIL.5W PATA Y PALA DIAM.200																1	1	1													

**RECAMBIOS**  
 ARMARIOS SNACK-2100  
 Octubre-2012





MODELOS

Nº	CÓDIGO	DESCRIPCIÓN	MODELOS														
			SNACK	AFP-2103	AFP-2104	AFP-2105	AFP-2106	AF-2104-P	AF-2105-P	AF-2106-P	AF-2104-C	AF-2105-C	AF-2106-C	AEP-2103			
71	6021010035	CONDEN.ARRANQUE SC-117U5017 80 mF															
71	6021010036	CONDEN.ARRANQUE TL-G 17U5014 60 mF						1	1	1							
71	6021010195	CONDS.ARRANQUE NEK-6214-Z 220V	1	1	1	1	1	1	1	1	1	1	1	1	1	1	1
73	6021010042	RELE ARRANQUE COMPRESOR SC-12CL										1	1	1			
73	6021010044	RELE ARRANQUE COMPRESOR TL-5G 6000						1	1	1							
73	6021010194	RELE ARRANQUE NEK-6214-Z 220V	1	1	1	1	1	1	1	1	1	1	1	1	1	1	1
80	A171010116	UD.EVAP.AFP-2100 COMPACTO	1	1	1	1	1	1	1	1	1	1	1	1	1	1	1
81	A171010115	UD.EV.AF1400C,2100C CONG.COMP.										1	1	1			

**LISTADO MODIFICACIONES RESPECTO ACTUALIZACION Oct-2012**

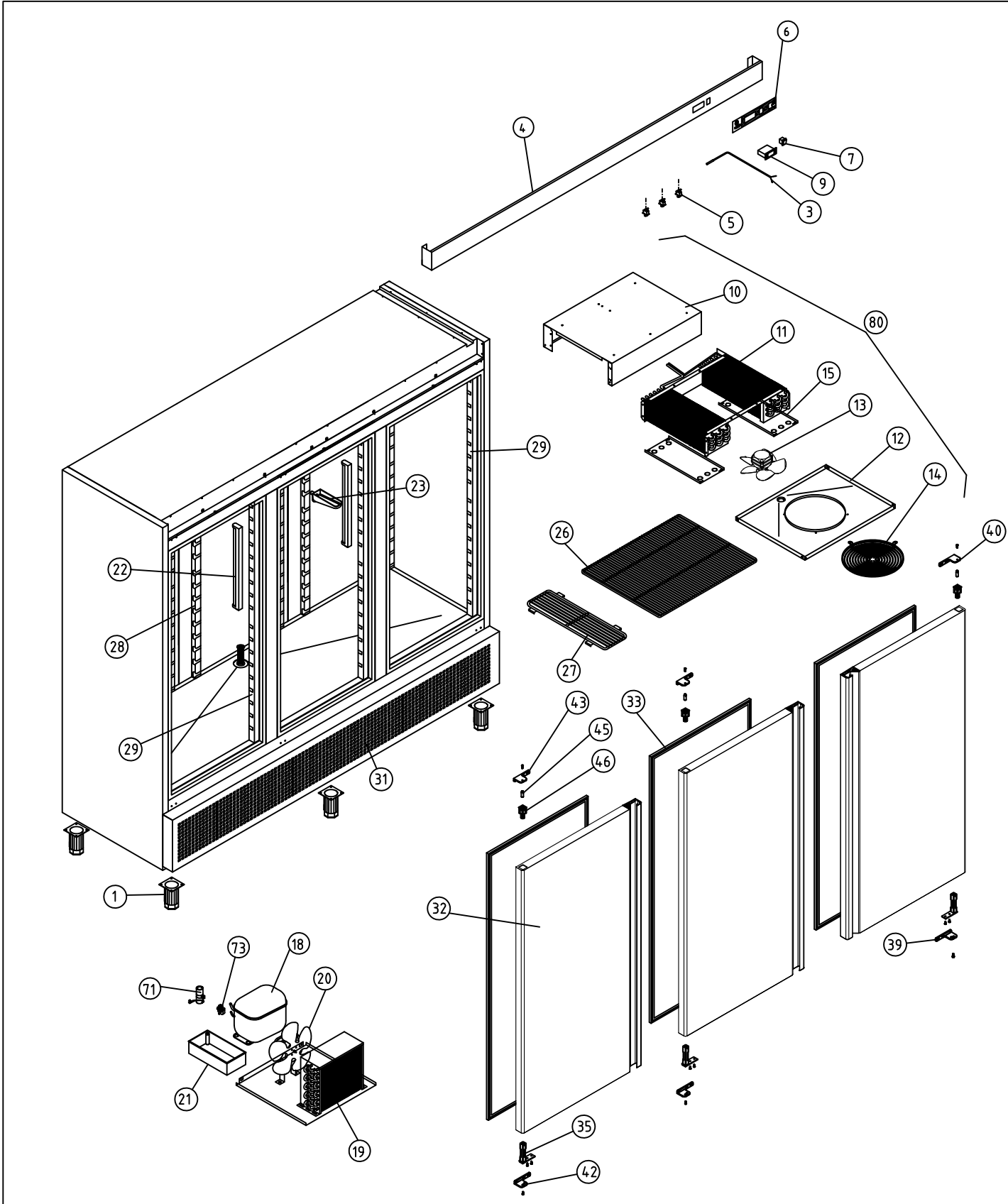
Nº	Mar-2011		Oct-2012		RELACION
	CODIGO	DESCRIPCION	CODIGO	DESCRIPCION	
2	6021130002	INTERRUPTOR UNIPOL.LUMINOS.AMB	6021130066	INTERRUPT. UNIPOL. NEGRO/ROJO	INTERCAMBIABLE
3	6021350021	SONDA CAREL NTC030HP00 3MT	6021350113	SONDA NTC 2,5 MTS	INTERCAMBIABLE
4	A109010503	CABEZA AFP-2100	A109010839	CABEZA AFP-2100	NO INTERCAMBIABLE
4	A109010509	CABEZA AF-2100 DPTO	A109010906	CABEZA AF-2100 DPTO	NO INTERCAMBIABLE
6	6023010408	PEG.CUAD.FAGOR REFR.347,5X60	6023010553	PEG.FAGOR GAMA CONCEPT	NO INTERCAMBIABLE
6	6023010406	PEG.CUAD.FAG ARMAR.DPTO	6023010554	PEG. FAGOR GAMA CONCEPT DPTO	NO INTERCAMBIABLE
7	6021130001	INT.BIP.AMB.O/I CONTAC.REFORZ.	6021130065	INTERRUPTOR BIP. O/I NEGRO/ROJO	INTERCAMBIABLE
8	6021130002	INTERRUPTOR UNIPOL.LUMINOS.AMB	6021130066	INTERRUPTOR UNIPOL. NEGRO/ROJO	INTERCAMBIABLE
9	6021350018	TERMOS REFRI CAREL PYCO1SN515	A177090018	CONJ.TERM. REF. 220v 50Hz	INTERCAMBIABLE
31	A109010353	REJILLA MOTOR 1400	A109010859	REJILLA GRUPO AFP-2100	INTERCAMBIABLE
32	A169010090	PUE PEQ AFP/AFN IZD	A169010190	PUE PEQ AFP/AFN CONCEPT IZD	INTERCAMBIABLE
32	A169010093	PUE PEQ AFP/AFN DCH	A169010191	PUE PEQ AFP/AFN CONCEPT DCHA	INTERCAMBIABLE
32	A169010081	PUE CAR AFP/AFN IZD	A169010188	PUE CARN AFP/AFN CONCEPT IZD	INTERCAMBIABLE
32	A169010086	PUE CAR AFP/AFN DCH	A169010189	PUE CARN AFP/AFN CONCEPT DCHA	INTERCAMBIABLE
57	6021350010	TERM CAREL CONG.PYCO1LO016	A177090020	CONJ. TERM.CONG. 220v 50Hz	INTERCAMBIABLE
58	6021250005	RESIST.BANDEJA 700-20W	6021250011	RESIST.BANDEJA DEPART.18W	NO INTERCAMBIABLE
60	6031070067	PUERT. CRIST. AFP IZQ.	6031070091	PT. CRISTAL ARM 684x1505	NO INTERCAMBIABLE
62	6033010002	TIRADOR ASA CROMADA	6033010135	TIRAD. PT. CRISTAL	NO INTERCAMBIABLE



A1 ARMARIOS SNACK					COD. PIEZA: X					
COTAS SIN TOLERANCIA DIN 7168-f					Material: MATERIAL ESPESOR					
					Acabado: ACABADO					
ANGULAR	GRADO TOLERANCIA	FINO	MEDIO	GRUESO						
	HASTA 10 mm		±1°	±1° 30'						
	MÁS DE 10 A 50 mm		±30'	±50'						
	MÁS DE 50 A 120 mm		±20'	±25'						
	MÁS DE 120 A 400 mm		±10'	±15'						
MÁS DE 400 mm		±5'	±10'							
LINEAL	GRADO TOLERANCIA	FINO	MEDIO	GRUESO						
	HASTA 3 mm	±0,05	±0,10	±0,15						
	MÁS DE 3 A 6 mm	±0,05	±0,10	±0,20						
	MÁS DE 6 A 30 mm	±0,10	±0,20	±0,50						
	MÁS DE 30 A 120 mm	±0,15	±0,30	±0,80						
	MÁS DE 120 A 400 mm	±0,20	±0,50	±1,20						
	MÁS DE 400 A 1000 mm	±0,30	±0,80	±2,00						
MÁS DE 1000 A 2000 mm	±0,50	±1,20	±3,00							
COMUN A		MODELO	Ud.	MODELO	Ud.	MODELO	Ud.	MODELO	Ud.	MODELO
		AFP-2103	1							
A4		Nombre			Fecha			 Fagofri, s.a.		
Dibujado		B. MORENO			Oct-2012					
Modificado										
Escala		RECAMBIOS AFP-2103								Código máquina:
1:30										CODIGO

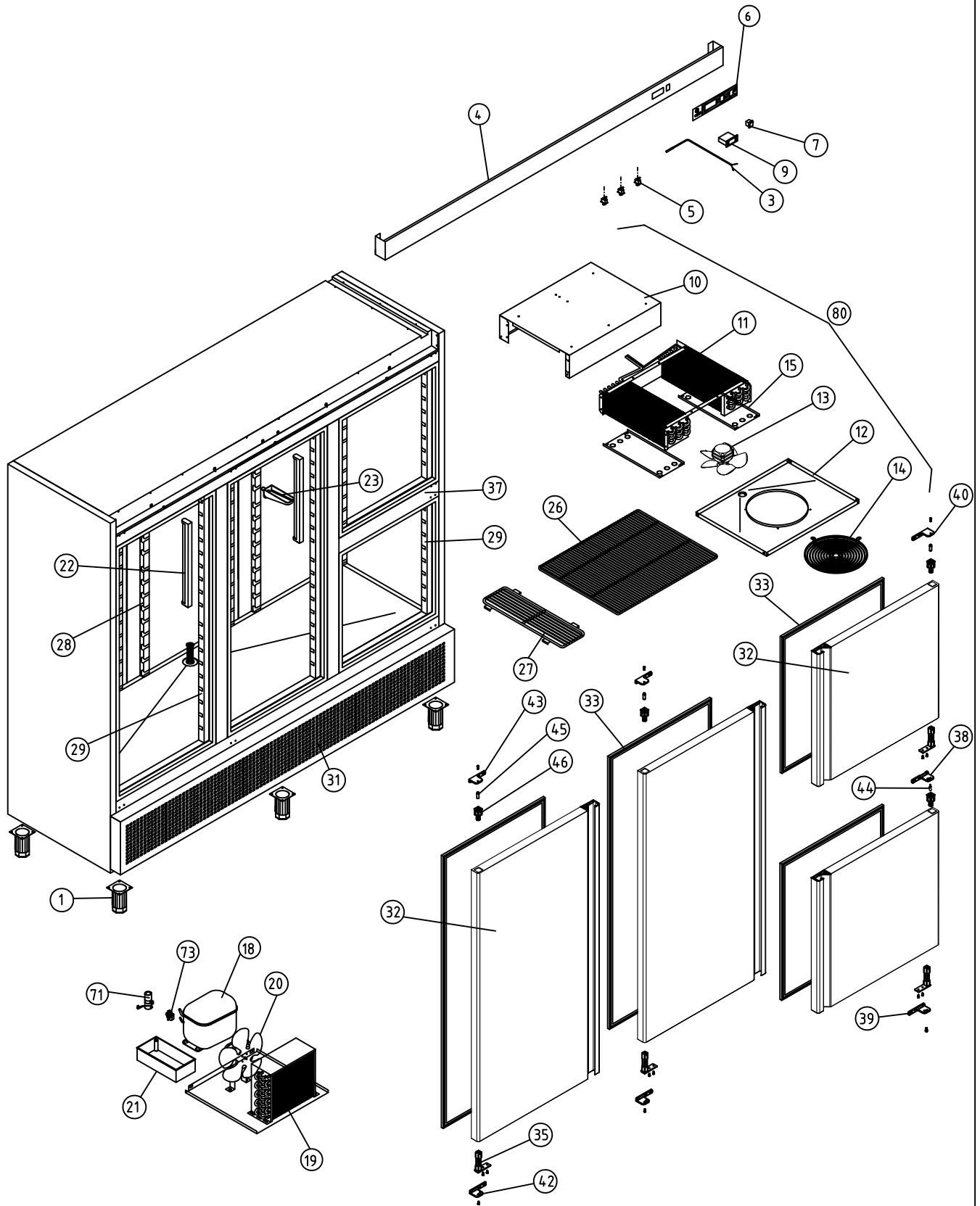

A1 ARMARIOS SNACK				COD. PIEZA: X											
COTAS SIN TOLERANCIA DIN 7168-f				Material: MATERIAL ESPESOR											
				Acabado: ACABADO											
ANGULAR	GRADO TOLERANCIA	FINO	MEDIO	GRUESO											
	HASTA 10 mm		±1°	±1° 30'											
	MÁS DE 10 A 50 mm		±30'	±50'											
	MÁS DE 50 A 120 mm		±20'	±25'											
COMUN A	MÁS DE 120 A 400 mm		±10'	±15'	MODELO	Ud.	MODELO	Ud.	MODELO	Ud.	MODELO	Ud.	MODELO	Ud.	
	MÁS DE 400 mm		±5'	±10'	AFP-2104	1									
LINEAL	GRADO TOLERANCIA	FINO	MEDIO	GRUESO	A4		Nombre		Fecha		 Fagofri, s.a.				
	HASTA 3 mm		±0,05	±0,10	±0,15	Dibujado		B. MORENO		Oct-2012					
	MÁS DE 3 A 6 mm		±0,05	±0,10	±0,20	Modificado									
	MÁS DE 6 A 30 mm		±0,10	±0,20	±0,50	Escala						Código máquina:			
	MÁS DE 30 A 120 mm		±0,15	±0,30	±0,80	1:30						CODIGO			
	MÁS DE 120 A 400 mm		±0,20	±0,50	±1,20										
MÁS DE 400 A 1000 mm		±0,30	±0,80	±2,00											
MÁS DE 1000 A 2000 mm		±0,50	±1,20	±3,00											

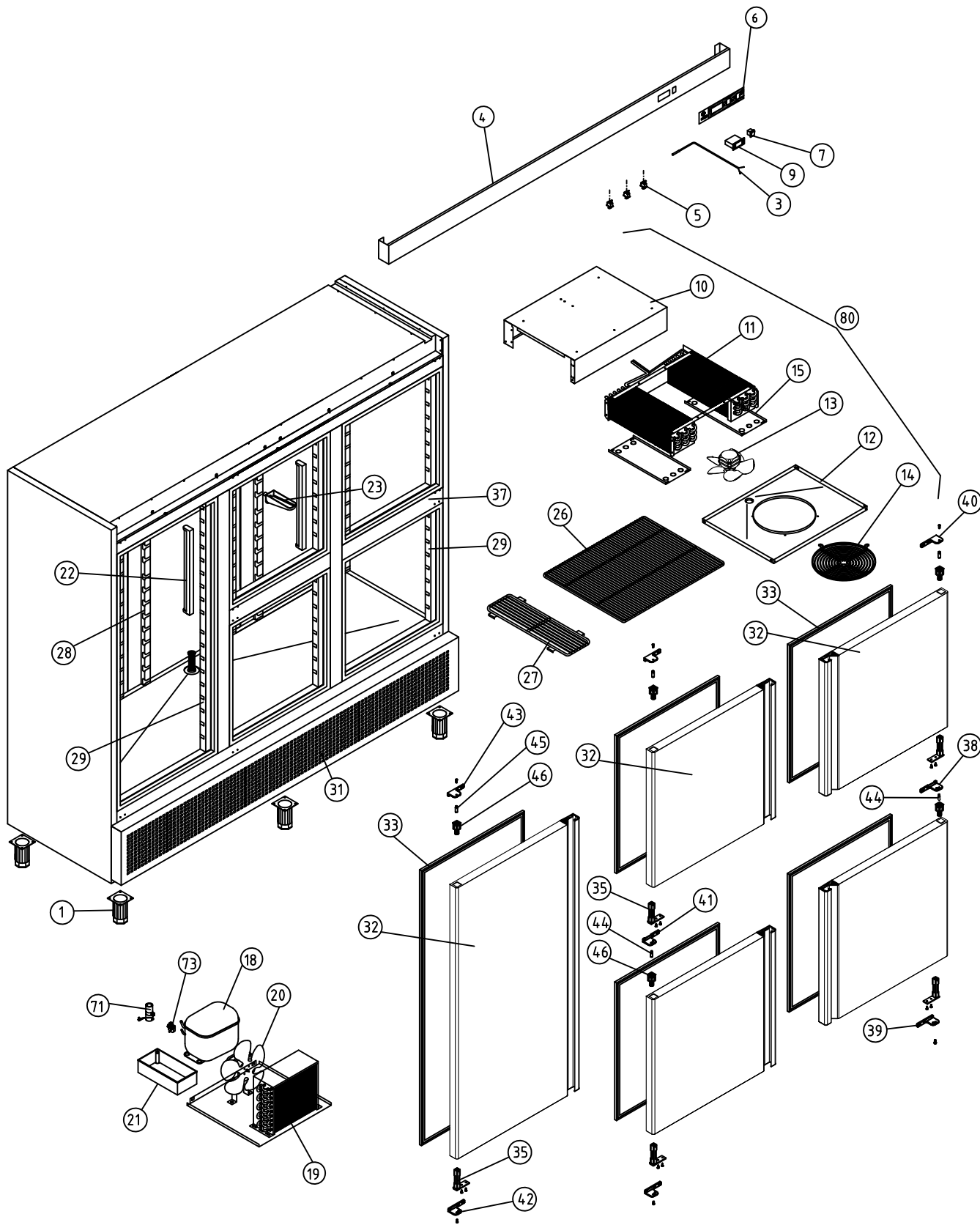

A1 ARMARIOS SNACK

COD. PIEZA: X

COTAS SIN TOLERANCIA DIN 7168-f

Material: MATERIAL ESPESOR

SUSTITUYE A:

Acabado: ACABADO

SUSTITUIDO POR:

ANGULAR	GRADO TOLERANCIA	FINO	MEDIO	GRUESO
	HASTA 10 mm		±1°	±1° 30'
MÁS DE 10 A 50 mm		±30'	±50'	
MÁS DE 50 A 120 mm		±20'	±25'	
MÁS DE 120 A 400 mm		±10'	±15'	
MÁS DE 400 mm		±5'	±10'	

LINEAL	GRADO TOLERANCIA	FINO	MEDIO	GRUESO
	HASTA 3 mm		±0,05	±0,10
MÁS DE 3 A 6 mm		±0,05	±0,10	±0,20
MÁS DE 6 A 30 mm		±0,10	±0,20	±0,50
MÁS DE 30 A 120 mm		±0,15	±0,30	±0,80
MÁS DE 120 A 400 mm		±0,20	±0,50	±1,20
MÁS DE 400 A 1000 mm		±0,30	±0,80	±2,00
MÁS DE 1000 A 2000 mm		±0,50	±1,20	±3,00

COMUN A	MODELO	Ud.	MODELO	Ud.	MODELO	Ud.	MODELO	Ud.	MODELO	Ud.
		AFP-2105	1							

A4	Nombre	Fecha
Dibujado	B. MORENO	Oct-2012
Modificado		



Escala	1:30	RECAMBIOS AFP-2105	Código máquina: CODIGO
--------	------	--------------------	---------------------------

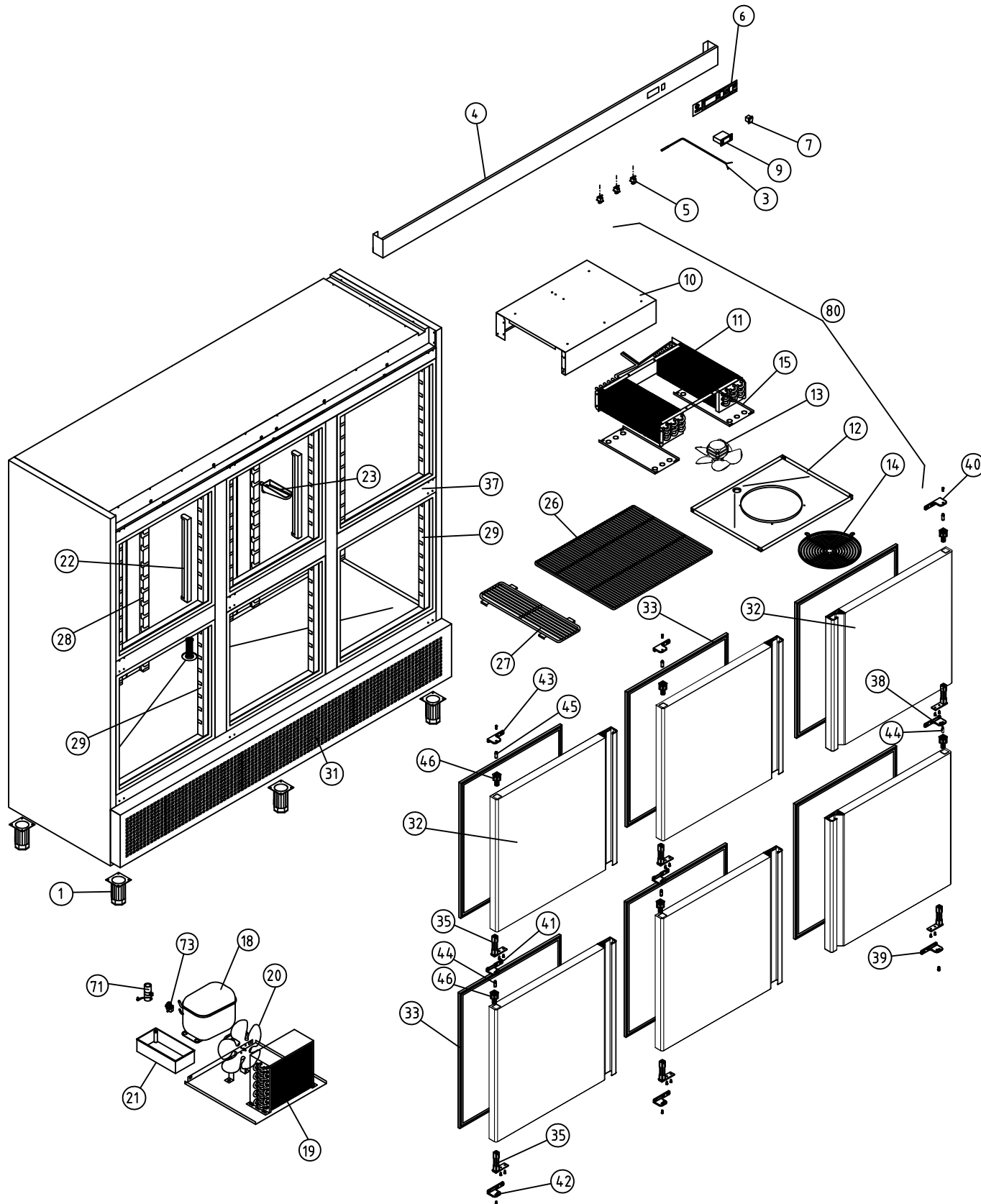

A1 ARMARIOS SNACK				COD. PIEZA: X							
COTAS SIN TOLERANCIA DIN 7168-f				Material: MATERIAL ESPESOR							
				Acabado: ACABADO							
ANGULAR	GRADO TOLERANCIA	FINO	MEDIO	GRUESO							
	HASTA 10 mm		±1°	±1° 30'							
	MÁS DE 10 A 50 mm		±30'	±50'							
	MÁS DE 50 A 120 mm		±20'	±25'							
	MÁS DE 120 A 400 mm		±10'	±15'							
MÁS DE 400 mm		±5'	±10'								
LINEAL	GRADO TOLERANCIA	FINO	MEDIO	GRUESO							
	HASTA 3 mm		±0,05	±0,10	±0,15						
	MÁS DE 3 A 6 mm		±0,05	±0,10	±0,20						
	MÁS DE 6 A 30 mm		±0,10	±0,20	±0,50						
	MÁS DE 30 A 120 mm		±0,15	±0,30	±0,80						
MÁS DE 120 A 400 mm		±0,20	±0,50	±1,20							
MÁS DE 400 A 1000 mm		±0,30	±0,80	±2,00							
MÁS DE 1000 A 2000 mm		±0,50	±1,20	±3,00							
COMUN A		MODELO	Ud.	MODELO	Ud.	MODELO	Ud.	MODELO	Ud.	MODELO	
		AFP-2106	1								
A4		Nombre	Fecha		 Fagofri, s.a.						
Dibujado		B. MORENO	Oct-2012								
Modificado											
Escala		1:30				RECAMBIOS AFP-2106				Código máquina: CODIGO	



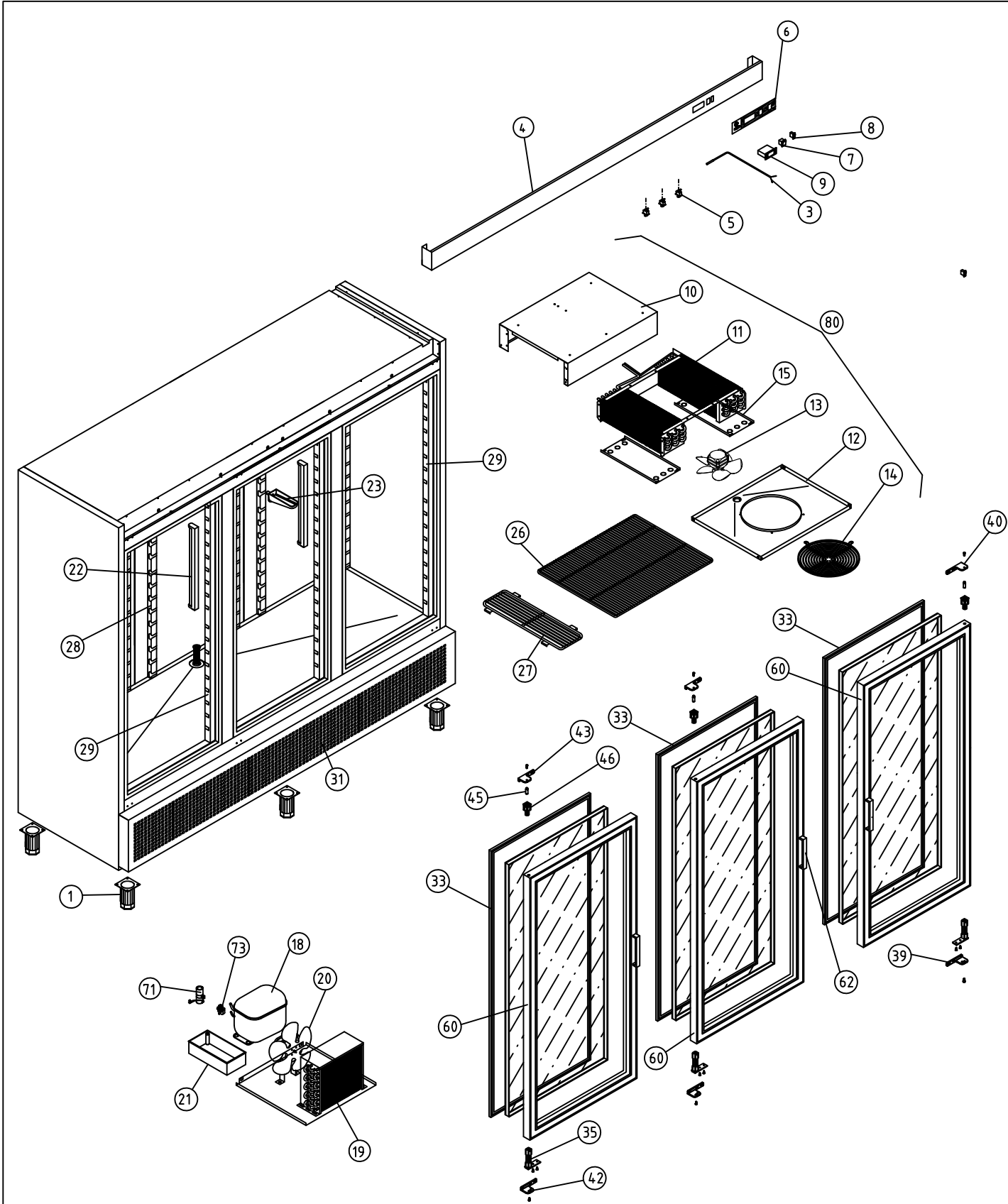

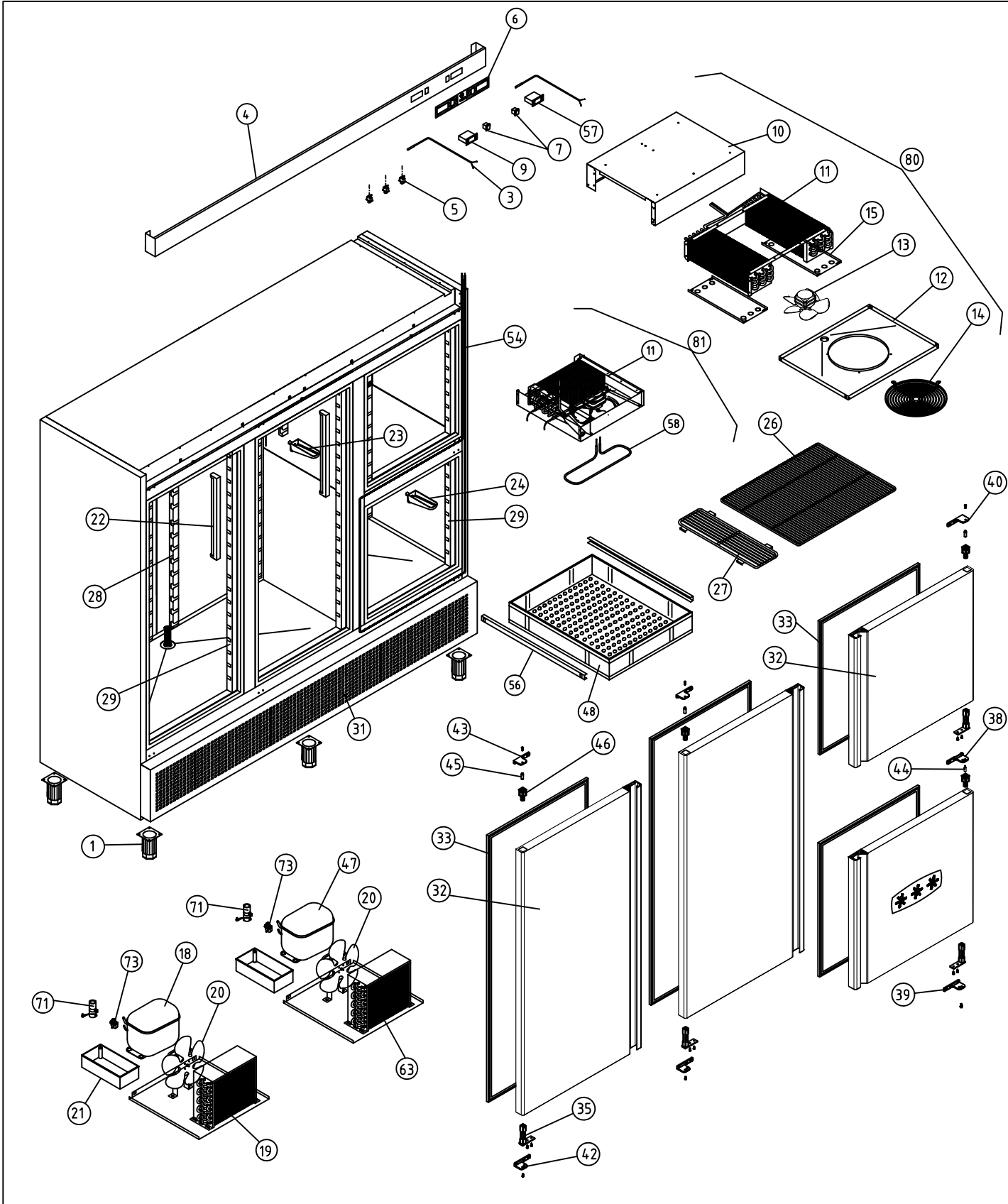

A1 ARMARIOS SNACK				COD. PIEZA: X								
COTAS SIN TOLERANCIA DIN 7168-f				Material: MATERIAL ESPESOR								
				Acabado: ACABADO								
ANGULAR	GRADO TOLERANCIA	FINO	MEDIO	GRUESO								
	HASTA 10 mm		±1°	±1° 30'								
	MÁS DE 10 A 50 mm		±30'	±50'								
	MÁS DE 50 A 120 mm		±20'	±25'								
COMUN A	MÁS DE 120 A 400 mm		±10'	±15'	MODELO	Ud.	MODELO	Ud.	MODELO	Ud.	MODELO	Ud.
	MÁS DE 400 mm		±5'	±10'	AEP-2103	1						
LINEAL	GRADO TOLERANCIA	FINO	MEDIO	GRUESO								
	HASTA 3 mm		±0,05	±0,10	±0,15	A4		Nombre		Fecha		
	MÁS DE 3 A 6 mm		±0,05	±0,10	±0,20	Dibujado		B. MORENO		Oct-2012		
	MÁS DE 6 A 30 mm		±0,10	±0,20	±0,50	Modificado						
	MÁS DE 30 A 120 mm		±0,15	±0,30	±0,80	Escala						
MÁS DE 120 A 400 mm		±0,20	±0,50	±1,20	1:30		RECAMBIOS AEP-2103					
MÁS DE 400 A 1000 mm		±0,30	±0,80	±2,00					Código máquina:			
MÁS DE 1000 A 2000 mm		±0,50	±1,20	±3,00					CODIGO			
<b>FAGOR</b>										Fagofri, s.a.		



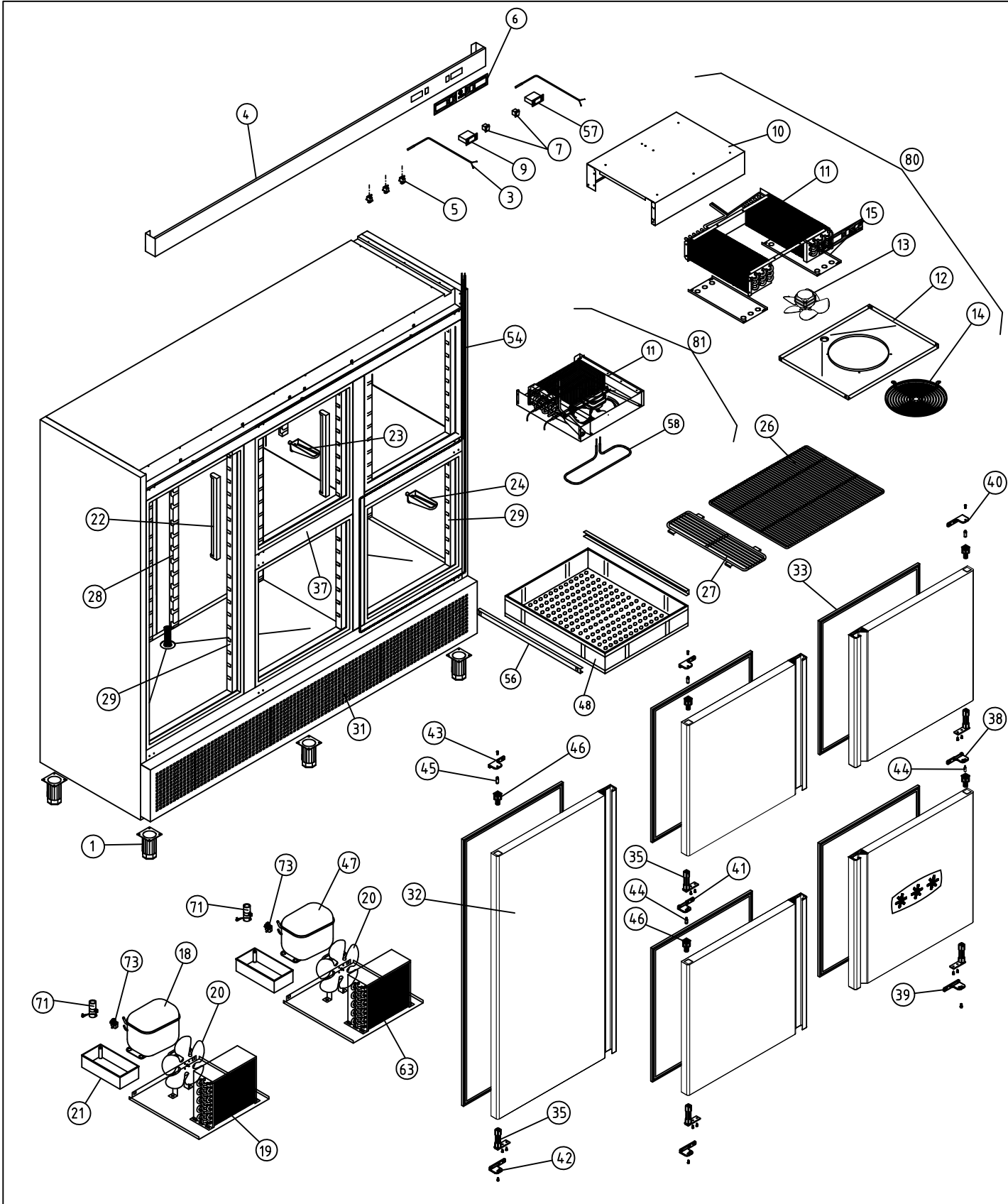

A1 ARMARIOS SNACK DEPARTAMENTO MANTENIMIENTO CONGELADOS						COD. PIEZA: X				
COTAS SIN TOLERANCIA DIN 7168-f						Material: MATERIAL ESPESOR				
Material: MATERIAL ESPESOR						SUSTITUYE A:				
Acabado: ACABADO						SUSTITUIDO POR:				
ANGULAR	GRADO TOLERANCIA	FINO	MEDIO	GRUESO						
	HASTA 10 mm		±1°	±1° 30'						
	MÁS DE 10 A 50 mm		±30'	±50'						
	MÁS DE 50 A 120 mm		±20'	±25'						
COMUN A	MÁS DE 120 A 400 mm		±10'	±15'	MODELO	Ud.	MODELO	Ud.	MODELO	Ud.
	MÁS DE 400 mm		±5'	±10'	AF-2104-C	1				
LINEAL	GRADO TOLERANCIA	FINO	MEDIO	GRUESO						
	HASTA 3 mm		±0,05	±0,10	A4		Nombre		Fecha	
	MÁS DE 3 A 6 mm		±0,05	±0,10	Dibujado		B. MORENO		Oct-2012	
	MÁS DE 6 A 30 mm		±0,10	±0,20	Modificado					
	MÁS DE 30 A 120 mm		±0,15	±0,30	Escala					
	MÁS DE 120 A 400 mm		±0,20	±0,50	1:30					
MÁS DE 400 A 1000 mm		±0,30	±0,80	RECAMBIOS AF-2104-C					Código máquina:	
MÁS DE 1000 A 2000 mm		±0,50	±1,20						CODIGO	





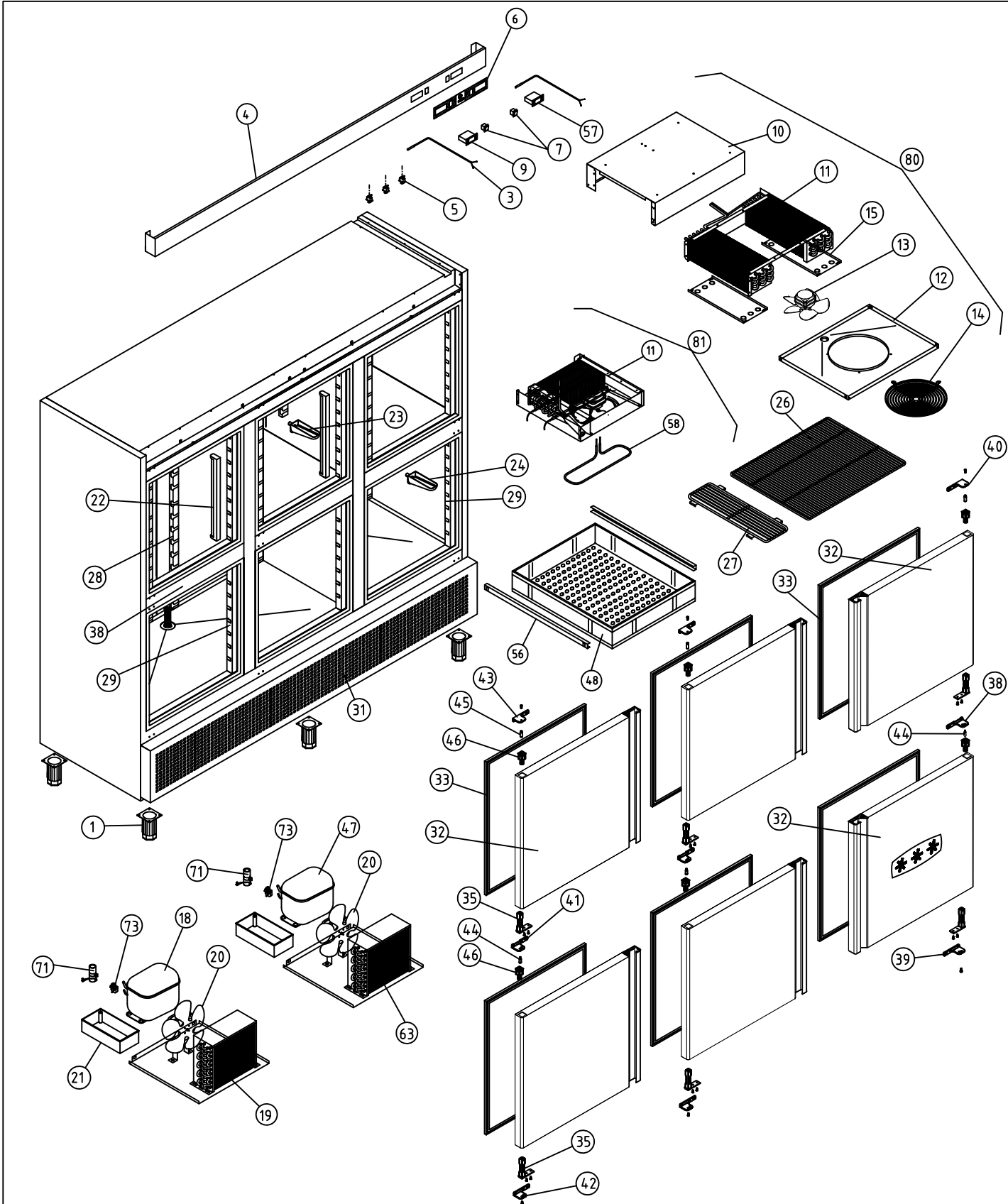

A1 ARMARIOS SNACK DEPARTAMENTO MANTENIMIENTO CONGELADOS						COD. PIEZA: X								
COTAS SIN TOLERANCIA DIN 7168-f						Material: MATERIAL ESPESOR								
Material: MATERIAL ESPESOR						SUSTITUYE A:								
Acabado: ACABADO						SUSTITUIDO POR:								
ANGULAR	GRADO TOLERANCIA	FINO	MEDIO	GRUESO	COMUN A	MODELO	Ud.	MODELO	Ud.	MODELO	Ud.	MODELO	Ud.	MODELO
	HASTA 10 mm		±1°	±1° 30'		AF-2105-C	1							
	MAS DE 10 A 50 mm		±30'	±50'										
	MAS DE 50 A 120 mm		±20'	±25'										
	MAS DE 120 A 400 mm		±10'	±15'										
MAS DE 400 mm		±5'	±10'											
LINEAL	GRADO TOLERANCIA	FINO	MEDIO	GRUESO	A4	Nombre		Fecha		 Fagofri, s.a.		Código máquina:		
	HASTA 3 mm	±0,05	±0,10	±0,15	Dibujado	B. MORENO		Oct-2012				CODIGO		
	MAS DE 3 A 6 mm	±0,05	±0,10	±0,20	Modificado									
	MAS DE 6 A 30 mm	±0,10	±0,20	±0,50	Escala									
	MAS DE 30 A 120 mm	±0,15	±0,30	±0,80	1:30					RECAMBIOS AF-2105-C				
MAS DE 120 A 400 mm	±0,20	±0,50	±1,20											
MAS DE 400 A 1000 mm	±0,30	±0,80	±2,00											
MAS DE 1000 A 2000 mm	±0,50	±1,20	±3,00											

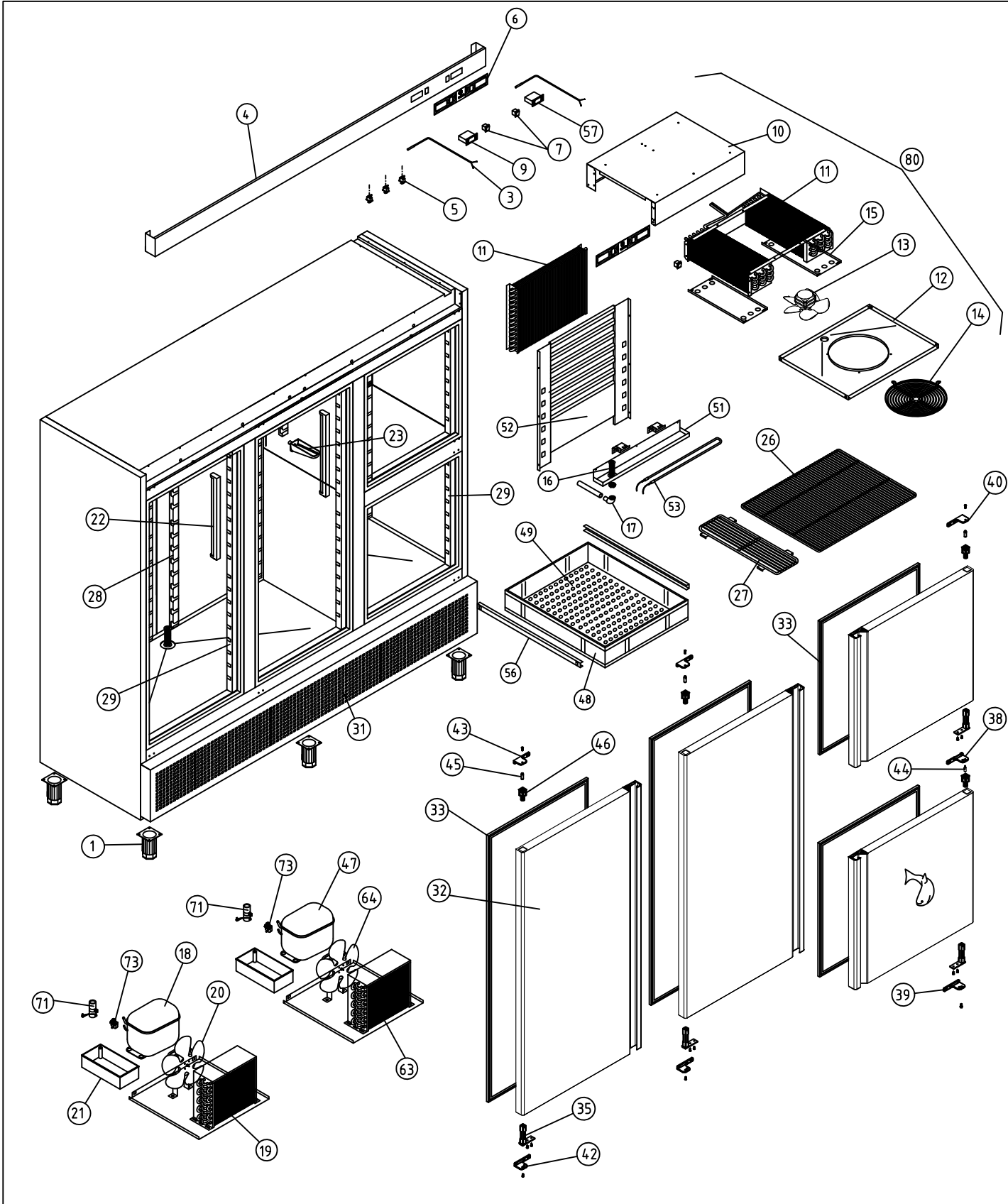

A1 ARMARIOS SNACK DEPARTAMENTO MANTENIMIENTO CONGELADOS						COD. PIEZA: X									
COTAS SIN TOLERANCIA DIN 7168-f						Material: MATERIAL ESPESOR									
Material: MATERIAL ESPESOR						SUSTITUYE A:									
Acabado: ACABADO						SUSTITUIDO POR:									
ANGULAR	GRADO TOLERANCIA	FINO	MEDIO	GRUESO											
	HASTA 10 mm		±1°	±1° 30'											
	MÁS DE 10 A 50 mm		±30'	±50'											
	MÁS DE 50 A 120 mm		±20'	±25'											
COMUN A	MÁS DE 120 A 400 mm		±10'	±15'	MODELO	Ud.	MODELO	Ud.	MODELO	Ud.	MODELO	Ud.	MODELO	Ud.	
	MÁS DE 400 mm		±5'	±10'	AF-2106-C	1									
LINEAL	GRADO TOLERANCIA	FINO	MEDIO	GRUESO											
	HASTA 3 mm		±0,05	±0,10	±0,15	A4		Nombre		Fecha		 Fagofri, s.a.			
	MÁS DE 3 A 6 mm		±0,05	±0,10	±0,20	Dibujado		B. MORENO		Oct-2012					
	MÁS DE 6 A 30 mm		±0,10	±0,20	±0,50	Modificado									
	MÁS DE 30 A 120 mm		±0,15	±0,30	±0,80	Escala						Código máquina:			
	MÁS DE 120 A 400 mm		±0,20	±0,50	±1,20	1:30						CODIGO			
MÁS DE 400 A 1000 mm		±0,30	±0,80	±2,00	RECAMBIOS AF-2106-C										
MÁS DE 1000 A 2000 mm		±0,50	±1,20	±3,00											



A1 ARMARIOS SNACK DEPARTAMENTO PESCADO						COD. PIEZA: X						
COTAS SIN TOLERANCIA DIN 7168-f						Material: MATERIAL ESPESOR						
Material: MATERIAL ESPESOR						SUSTITUYE A:						
Acabado: ACABADO						SUSTITUIDO POR:						
ANGULAR	GRADO TOLERANCIA	FINO	MEDIO	GRUESO								
	HASTA 10 mm		±1°	±1° 30'								
	MÁS DE 10 A 50 mm		±30'	±50'								
	MÁS DE 50 A 120 mm		±20'	±25'								
COMUN A	MÁS DE 120 A 400 mm		±10'	±15'	MODELO	Ud.	MODELO	Ud.	MODELO	Ud.	MODELO	Ud.
	MÁS DE 400 mm		±5'	±10'	AF-2104-P	1						
LINEAL	GRADO TOLERANCIA	FINO	MEDIO	GRUESO								
	HASTA 3 mm	±0,05	±0,10	±0,15	A4	Nombre		Fecha		 Fagofri, s.a.		
	MÁS DE 3 A 6 mm	±0,05	±0,10	±0,20	Dibujado	B. MORENO		Oct-2012				
	MÁS DE 6 A 30 mm	±0,10	±0,20	±0,50	Modificado							
	MÁS DE 30 A 120 mm	±0,15	±0,30	±0,80	Escala							
	MÁS DE 120 A 400 mm	±0,20	±0,50	±1,20	1:30	RECAMBIOS AF-2104-P						
MÁS DE 400 A 1000 mm	±0,30	±0,80	±2,00									
MÁS DE 1000 A 2000 mm	±0,50	±1,20	±3,00									
										Código máquina:		
										CODIGO		

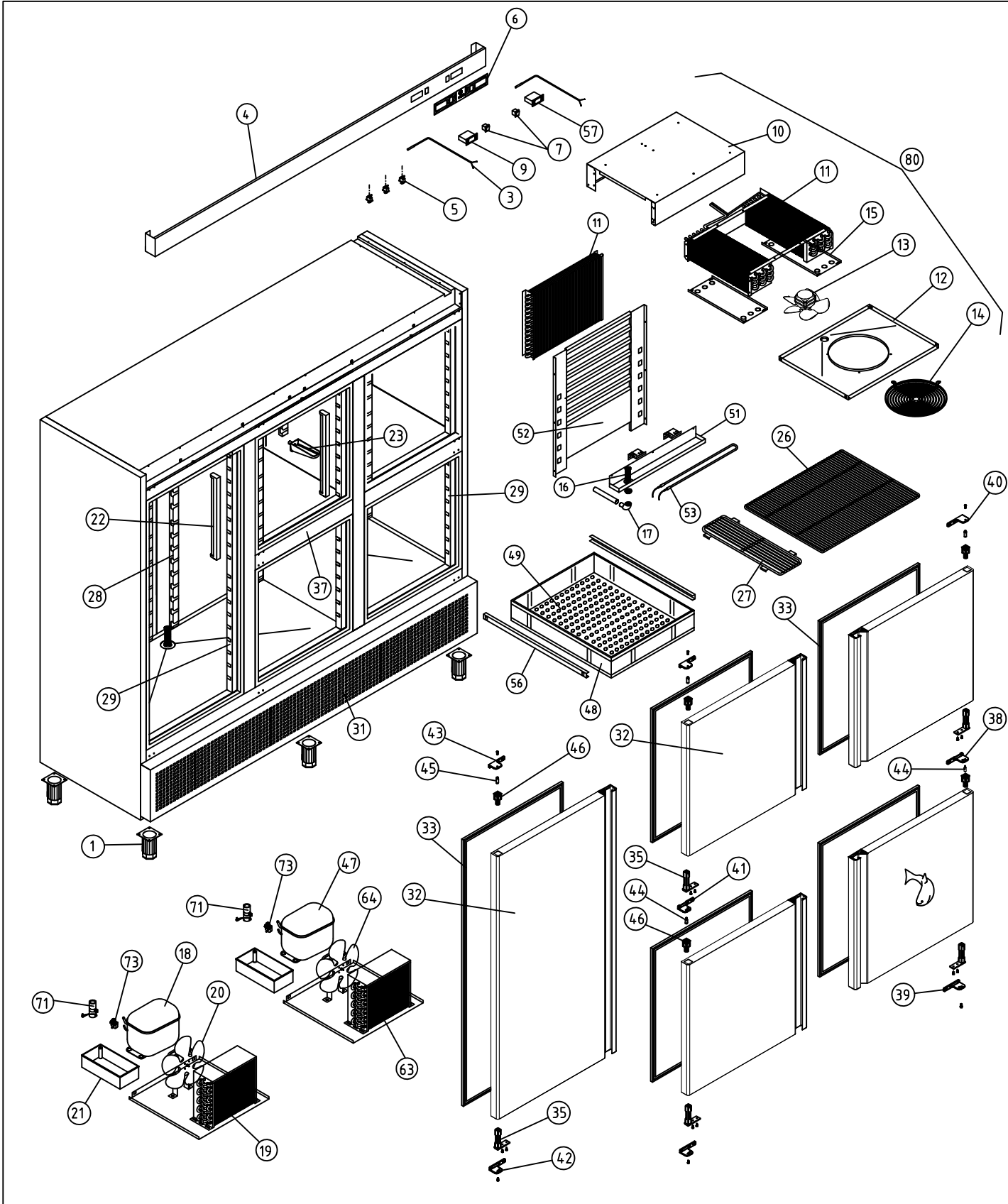

A1 ARMARIOS SNACK DEPARTAMENTO PESCADO						COD. PIEZA: X				
COTAS SIN TOLERANCIA DIN 7168-f						Material: MATERIAL ESPESOR				
Material: MATERIAL ESPESOR						SUSTITUYE A:				
Acabado: ACABADO						SUSTITUIDO POR:				
ANGULAR	GRADO TOLERANCIA	FINO	MEDIO	GRUESO						
	HASTA 10 mm		±1°	±1° 30'						
	MÁS DE 10 A 50 mm		±30'	±50'						
	MÁS DE 50 A 120 mm		±20'	±25'						
COMUN A	MÁS DE 120 A 400 mm		±10'	±15'	MODELO	Ud.	MODELO	Ud.	MODELO	Ud.
	MÁS DE 400 mm		±5'	±10'	AF-2105-P	1				
LINEAL	GRADO TOLERANCIA	FINO	MEDIO	GRUESO						
	HASTA 3 mm		±0,05	±0,10	±0,15	A4				
	MÁS DE 3 A 6 mm		±0,05	±0,10	±0,20	Nombre				
	MÁS DE 6 A 30 mm		±0,10	±0,20	±0,50	Dibujado B. MORENO				
	MÁS DE 30 A 120 mm		±0,15	±0,30	±0,80	Fecha Oct-2012				
	MÁS DE 120 A 400 mm		±0,20	±0,50	±1,20	Modificado				
MÁS DE 400 A 1000 mm		±0,30	±0,80	±2,00	Escala					
MÁS DE 1000 A 2000 mm		±0,50	±1,20	±3,00	1:30					
						 Fagofri, s.a.				
						Código máquina: <b>CODIGO</b>				
						<b>RECAMBIOS AF-2105-P</b>				

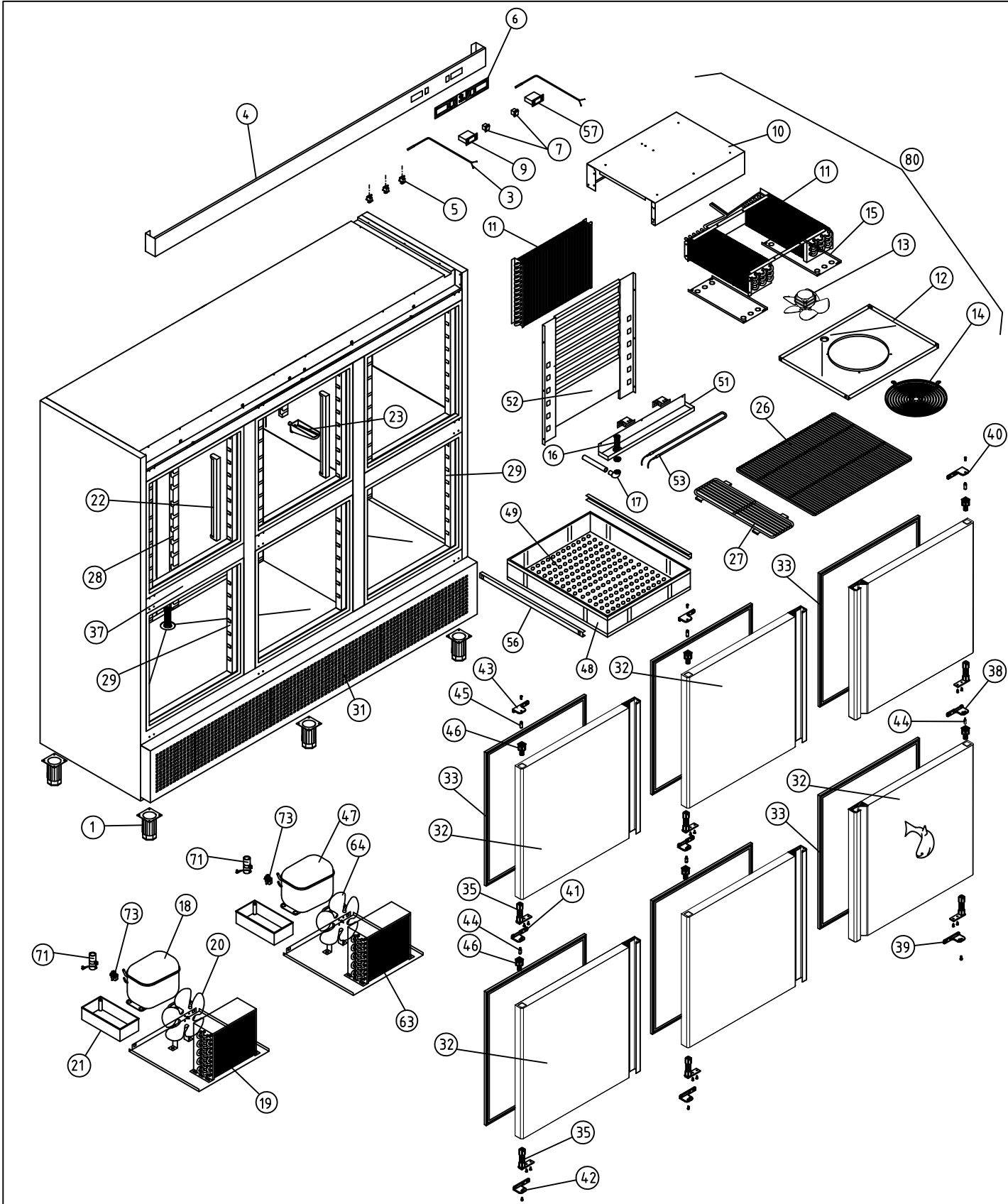

A1 ARMARIOS SNACK DEPARTAMENTO PESCADO						COD. PIEZA: X								
COTAS SIN TOLERANCIA DIN 7168-f						Material: MATERIAL ESPESOR								
Material: MATERIAL ESPESOR						SUSTITUYE A:								
Acabado: ACABADO						SUSTITUIDO POR:								
ANGULAR	GRADO TOLERANCIA	FINO	MEDIO	GRUESO	COMUN A	MODELO	Ud.	MODELO	Ud.	MODELO	Ud.	MODELO	Ud.	
	HASTA 10 mm		±1°	±1° 30'		AF-2106-P	1							
	MÁS DE 10 A 50 mm		±30'	±50'										
	MÁS DE 50 A 120 mm		±20'	±25'										
LINEAL	MÁS DE 120 A 400 mm		±10'	±15'										
	MÁS DE 400 mm		±5'	±10'										
	GRADO TOLERANCIA	FINO	MEDIO	GRUESO	A4	Nombre		Fecha		 Fagofri, s.a.				
	HASTA 3 mm	±0,05	±0,10	±0,15	Dibujado	B. MORENO		Oct-2012						
	MÁS DE 3 A 6 mm	±0,05	±0,10	±0,20	Modificado									
MÁS DE 6 A 30 mm	±0,10	±0,20	±0,50	Escala	RECAMBIOS AF-2106-P				Código máquina:					
MÁS DE 30 A 120 mm	±0,15	±0,30	±0,80	1:30					CODIGO					
MÁS DE 120 A 400 mm	±0,20	±0,50	±1,20											
MÁS DE 400 A 1000 mm	±0,30	±0,80	±2,00											
MÁS DE 1000 A 2000 mm	±0,50	±1,20	±3,00											