

---

DESPIECE TECNICO

---

**Cocedor de pasta  
Pasta cooker  
Cuiseur à pâtes  
Nudelkocher  
Cuocipasta  
Cozedor de massa**

**GAMA 900**

**Modelos:**

**CPG9-05 PLUS  
CPE9-05 PLUS  
CPG9-05 PLUS S  
CPE9-05 PLUS S**

***Marzo 2012 March***

***Revisado Marzo 2014 March Revised***

**FAGOR** 

---

F A G O R I N D U S T R I A L

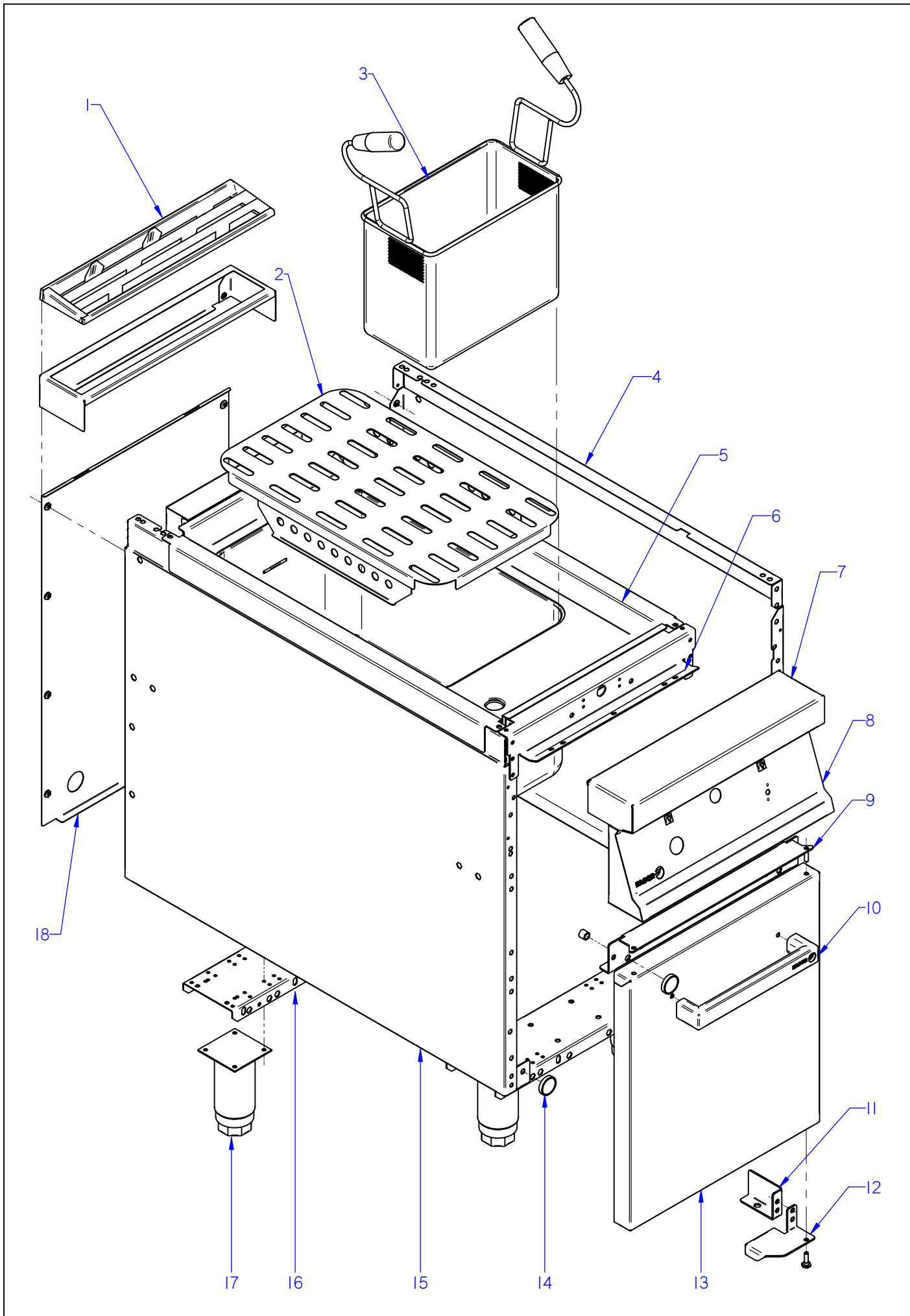

ITEM MARCADO EN COLOR = REPUESTO RECOMENDADO  
 COLOURED ITEM = RECOMMENDED SPARE PART

Nº plano / N° plane	Firma	Fecha / Date	Denominación / Denomination:	MUEBLE / FITTING	Lamina / Sheet	Fagor Industrial S.Coop. <b>FAGOR</b>
C-2937	<i>(Signature)</i>	2012-03	COCEDOR DE PASTA PLUS		1	Oñate

MOD.		COCEDOR DE PASTA / PASTA COOKER		ZONA / ZONE		MUEBLE / FITTING				PLANO DIAGRAM		C-2937		
ITEM	CODIGO REFERENCE	DENOMINACION	DENOMINATION	CPG9-05 PLUS	CPG9-05 PLUS S	CPE9-05 PLUS	CPE9-05 PLUS S					ELIMINADO ELIMINATED	INTRODUCID. INTRODUCED	NOTAS
1	R205425000	EMBELLECEDOR ESMALTE	REAR TRIM.	1	1	1	1							
S/Nº	R205438000	SOPORTE EMBELLECEDOR 1/2M	TRIM SUPPORT	1	1	1	1							
	Q419005000	REMACHE 4X8 ALMG3 / ALUMINIO	RIVET 4X8 ALMG3 / ALUMINIUM	12	12	12	12							
2	H066108000	SOPORTE CESTILLOS COMPLETO	COMPLETE BASKET SUPPORT	1	1	1	1							
3	H506500000	CESTILLO CUECEPASTA GN 1/3	BASKET	3	3	3	3							
4	X162814000	PANEL LATERAL DERECHO	RIGHT SIDE PANEL	1		1								
4	S222808000	PANEL LATERAL DCHO. SUSP.	SUSP. RIGHT SIDE PANEL		1		1							
	Q221345000	REMACHE EXAGONAL M10	HEXAGONAL RIVET M10	2	2	2	2							
	Q221343000	REMACHE EXAGONAL M6	HEXAGONAL RIVET M6	11	11	11	1							
	Q221342000	REMACHE EXAGONAL M5	HEXAGONAL RIVET M5	6	6	6	6							
5	H046101000	CUBA COMPLETA AD	COMPLETE TUB AD	1										
5	H046103000	CUBA COMPLETA SUSPEND. AD	COMPLETE TUB SUSPENDED		1									
5	H046104000	CUBA COMPLETA CPE AD	COMPLETE TUB CPE AD			1								
5	H046106000	CUBA COMPLETA CPE AD S	COMPLETE TUB CPE AD S				1							
	Q162030000	TUERCA EXAGONAL M5	HEXAGONAL NUT M5	6	6	3	3							
6	R042611000	ESCUA INTER ANTE MESA 0,5 M	BRACKET INTER FASTE. FRONT	1	1	1	1							
	Q221342000	REMACHE EXAGONAL M5	HEXAGONAL RIVET M5	4	4	4	4							
	Q012032000	TORNILLO EXAGONAL M5X15	HEXAGONAL BOLT M5X15	6	6	6	6							
7	U965415000	ANTERIOR MESA 0,5 M AD	BENCH FRONT 0.5 M AD	1		1								
	Q152004000	TORNIL. APLASTADO M5X13 A 304	FLAT HEADED SCREW M5x13 A 304	2		2								
	Q302022000	ARANDELA 16X6X1.2 A.304	WASHER 16X6X1.2 A.304	2		2								
8	H042801000	PORTAM. COMP. CPG9-05 AD	CONTROL HOLDER CPG9-05 AD	1	1									
8	H042805000	PORTAMANDOS COMPLET. CPE	CONTROL HOLDER CPE			1	1							
	Q152004000	TORNIL. APLASTADO M5X13 A 304	FLAT HEADED SCREW M5x13 A 304	4	4	4	4							
	U022836000	ESCUDO FAGOR	FAGOR EMBLEM	1	1	1	1							
	Q221023000	CLIP SUJECIÓN RÁPIDA Ø5	RAPID CONNECT CLIP Ø5	2	2	2	2							
9	X162669000	LISTON BISAGRA SUPERIOR DCHA	UPPER RIGHT HINGE STRIP	1	1	1	1							
	Q221342000	REMACHE EXAGONAL M5	HEXAGONAL RIVET M5	8	8	8	8							
	Q152004000	TORN. APLASTADO M5x13 A304	FLAT HEADED SCREW M5x13	4	4	4	4							

MOD.		COCEDOR DE PASTA / PASTA COOKER		ZONA / ZONE		MUEBLE / FITTING				PLANO DIAGRAM		C-2937		
ITEM	CODIGO REFERENCE	DENOMINACION	DENOMINATION	CPG9-05 PLUS	CPG9-05 PLUS S	CPE9-05 PLUS	CPE9-05 PLUS S					ELIMINADO ELIMINATED	INTRODUCID. INTRODUCED	NOTAS
10	Z710558000	ASA CAPOTA AD	AD HOOD HANDLE	1	1	1	1							
	Q162040000	TUERCA EXAGONAL M6	HEXAGONAL NUT M6	2	2	2	2							
	Q302022000	ARANDELA 16X6X1.2 A.304	WASHER 16X6X1.2 A.304	2	2	2	2							
11	U020526000	ESCUADRA REFUERZO BISAGRA	HINGE REINFORCEMENT BRACK	1		1								
12	U020511000	BISAGRA DERECHA INFERIOR	LOWER RIGHT HINGE	1		1								
12	X190504000	BISAGRA DCHA. INFERIOR SUSP.	LOWER RIGHT HINGE SUS.		1		1							
	Q012042000	TORNILLO EXAGONAL M6X15	HEXAGONAL BOLT M6X15	2		2								
	Q302022000	ARANDELA 16X6X1.2 A.304	WASHER 16X6X1.2 A.304	2		2								
	X960504000	TORNILLO DE GIRO M8	ROTATION BOLT M8	1	1	1	1							
	Q232050000	ARANDELA A8	WASHER A8	1	1	1	1							
	Q232040000	ARANDELA A6	WASHER A6	2	1	2	1							
13	12040935	PUERTA LATERAL AD	SIDE DOOR AD	1	1	1	1							
S/Nº	U020537000	CONTRAPUERTA LATERAL G900	SIDE DOOR REVERSE G900	1	1	1	1							
	Q419005000	REMACHE 4X8 ALMG3 / ALUMINIO	RIVET 4X8 ALMG3 / ALUMINIUM	4	4	4	4							
14	X960501000	IMAN	MAGNET	2	2	2	2							
S/Nº	X960502000	FIJACION IMAN	MAGNET ATTACHMENT	2	2	2	2							
	Q012021000	TORNILLO EXAGONAL M4X10	HEXAGONAL BOLT M4X10	2	2	2	2							
	Q232020000	ARANDELA A4	WASHER A4	2	2	2	2							
15	X162813000	PANEL LATERAL IZQUIERDO	LEFT SIDE PANEL	1		1								
15	S222807000	PANEL LATERAL IZDO. SUS.	SUSP. LEFT SIDE PANEL		1		1							
	Q221345000	REMACHE EXAGONAL M10	HEXAGONAL RIVET M10	2	2	2	2							
	Q221343000	REMACHE EXAGONAL M6	HEXAGONAL RIVET M6	11	1	11	1							
	Q221342000	REMACHE EXAGONAL M5	HEXAGONAL RIVET M5	6	6	6	6							
16	E052603000	LISTON SOPORTE PATAS 1/2 M AD	LEG SUPPORT STRIP 1/2 M AD	2		2								
	Q012042000	TORNILLO EXAGONAL M6x15	HEXAGONAL BOLT M6X15	8		8								
	Q302022000	ARANDELA 16x6x1,2 A304	WASHER 16X6X1.2 A.304	8		8								
	Q221343000	REMACHE EXAGONAL M6	HEXAGONAL RIVET M6	2		2								
17	X260151000	PATA REGULABLE	ADJUSTABLE LEG	4		4								
	Q411304000	REMACHE AVIBULB Ø 4,8	AVIBULB RIVET Ø 4.8	16		16								



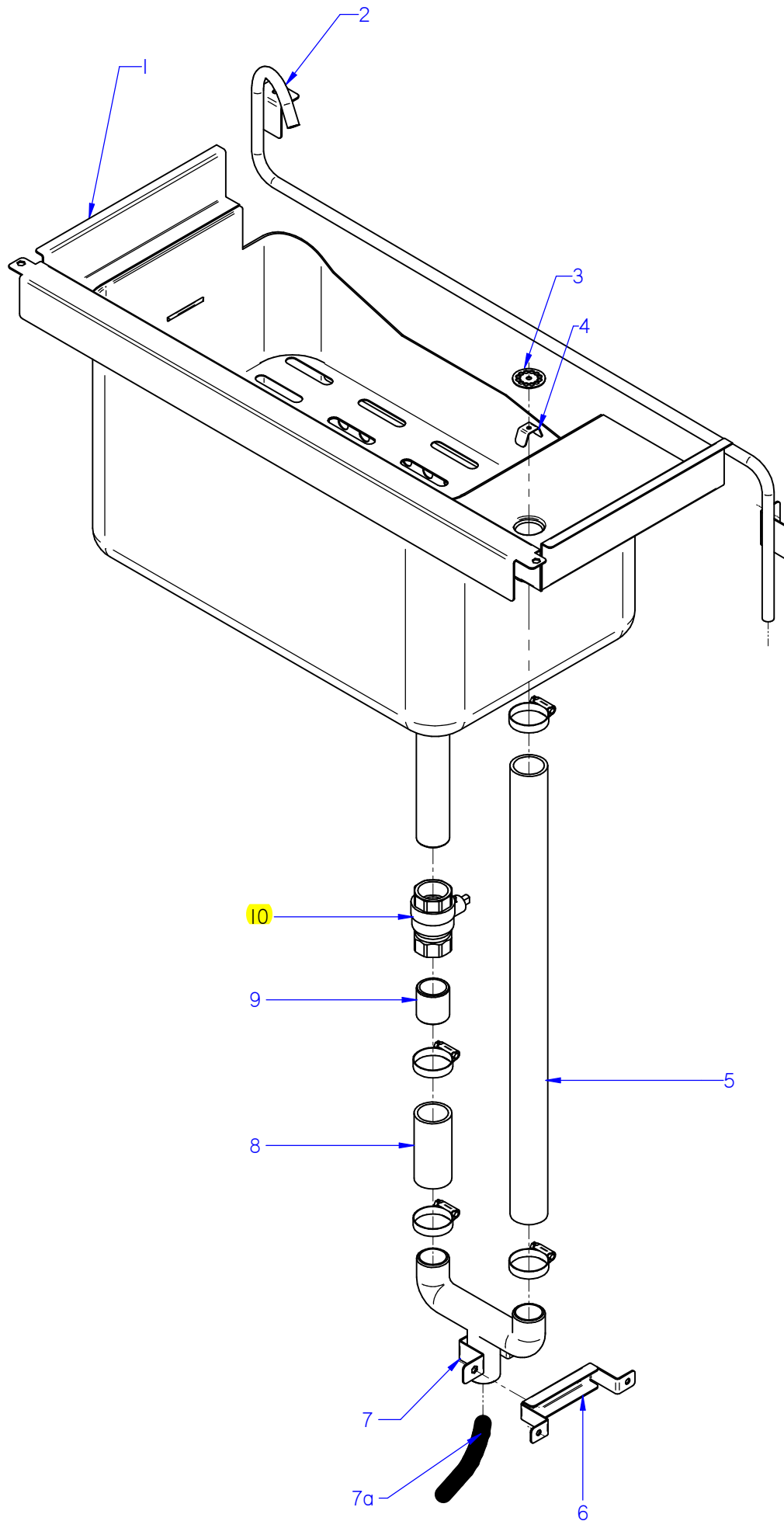

ITEM MARCADO EN COLOR = REPUESTO RECOMENDADO  
 COLOURED ITEM = RECOMMENDED SPARE PART

Nº plano / N° plane	Firma	Fecha / Date	Denominación / Denomination: TOMA DE AGUA Y DESAGÜE / INLET WATER DRAINING	Lamina / Sheet	Fagor Industrial S.Coop. <b>FAGOR</b>
C-2938	<i>(Signature)</i>	2012-03	COCEDOR DE PASTA PLUS	2	Oñate



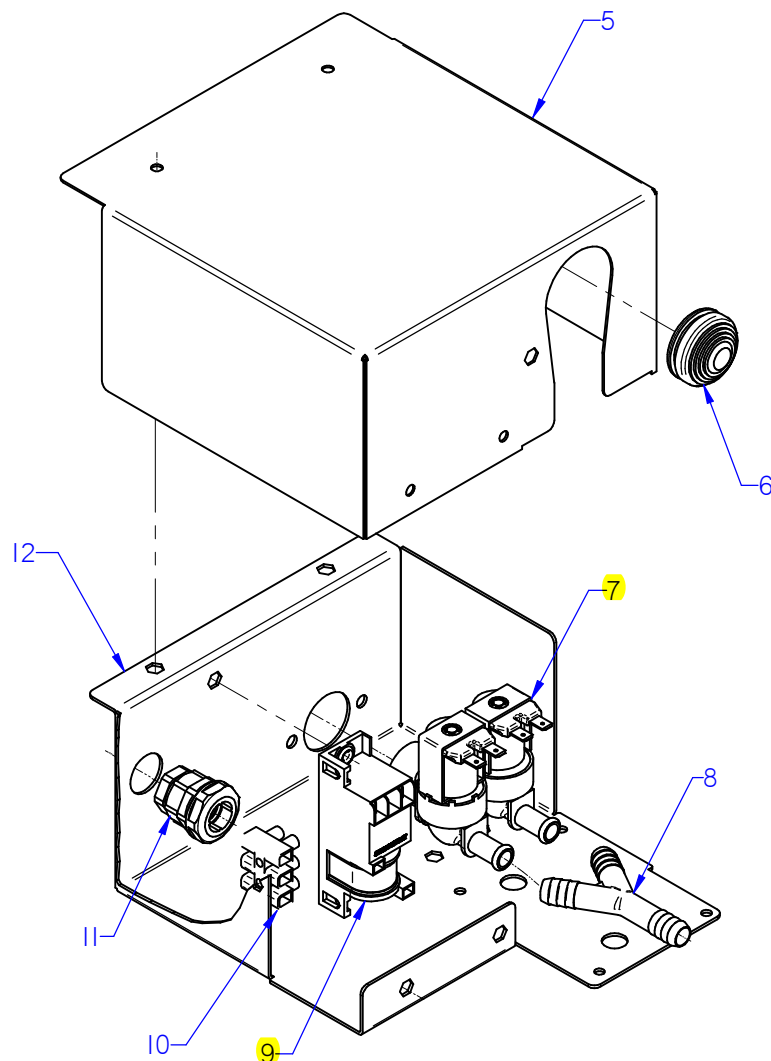
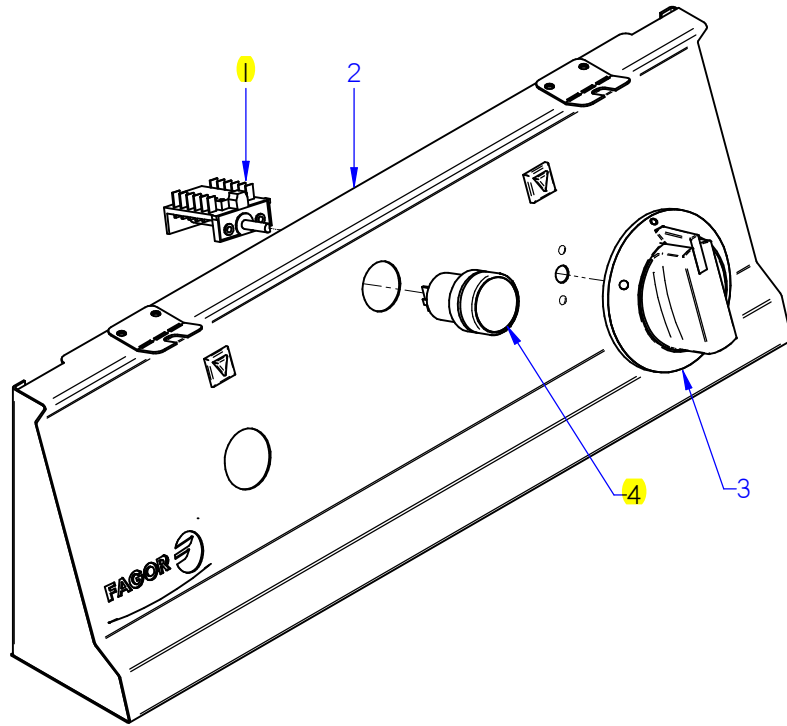

ITEM MARCADO EN COLOR = REPUESTO RECOMENDADO  
 COLOURED ITEM = RECOMMENDED SPARE PART

Nº plano / N° plane	Firma	Fecha / Date	Denominación / Denomination: FUNCIONAL ELECTRICO / FUNCTIONAL ELECTRICAL	Lamina / Sheet	agor Industrial S.Coop. <b>FAGOR</b>
C-2939	<i>(Signature)</i>	2012-03	COCED. DE PASTA CPG9-05 PLUS	3	Oñate





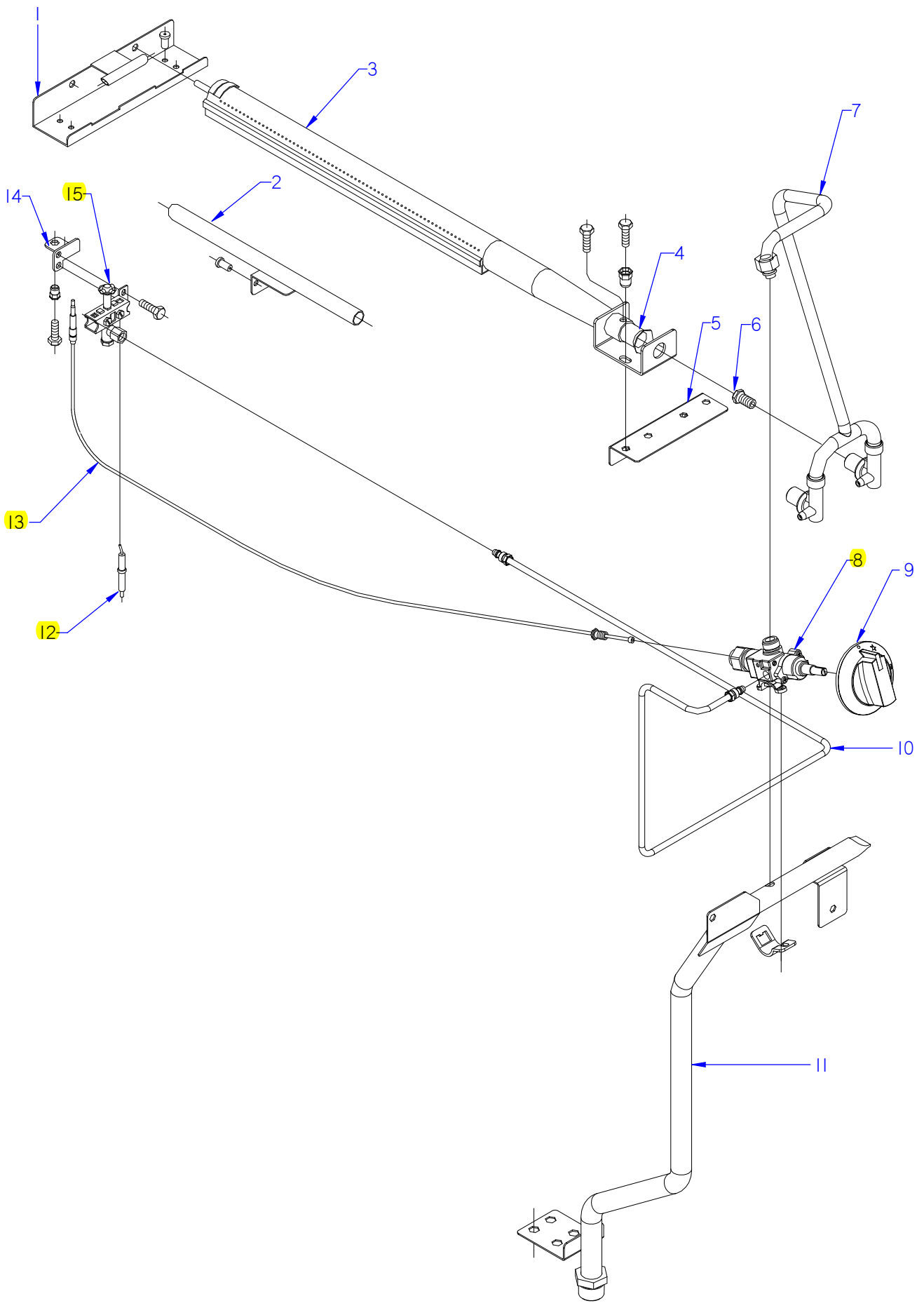

ITEM MARCADO EN COLOR = REPUESTO RECOMENDADO  
 COLOURED ITEM = RECOMMENDED SPARE PART

Nº plano / N° plane	Firma	Fecha / Date	Denominación / Denomination: PARTE FUNCIONAL GAS / FUNCTIONAL PART GAS	Lamina / Sheet	agor Industrial S.Coop. <b>FAGOR</b>
C-2940	<i>(Signature)</i>	2012-03	COCED. DE PASTA CPG9-05 PLUS	4	Oñate

MOD.		COCEDOR DE PASTA / PASTA COOKER		ZONA / ZONE		PARTE FUNCIONAL GAS / FUNCTIONAL PART GAS						PLANO DIAGRAM		C-2940	
ITEM	CODIGO REFERENCE	DENOMINACION	DENOMINATION	CPG9-05 PLUS	CPG9-05 PLUS S							ELIMINADO ELIMINATED	INTRODUCID. INTRODUCED	NOTAS	
1	H505705000	SOPORTE ENCENDIDO QUEMAD.	COMPLETE BURNER IGNITION	1	1										
	Q419005000	REMACHE 4x8 ALMG3 / ALUMINIO	RIVET 4X8 ALMG3 / ALUMINIUM	2	2										
	Q302022000	ARANDELA 16X6X1.2 A.304	WASHER 16X6X1.2 A.304	2	2										
2	H045703000	TUBO ENCEND.COMPL CPG900 AD	COMP PILOT IGNITION PIPE	1	1										
	Q081365000	TOR. ALOMADO 4,8X19 H.ZINCADO	CURVED SCREW 4.8X19 H.ZINC	2	2										
3	H505700000	QUEMADOR COMPLETO CP	COMPLETE BURNER CP	2	2										
4	U325707000	REGULADOR DE AIRE (QUEMAD.)	AIR CONTROL (BURNER)	2	2										
	Q012032000	TORNILLO EXAGON. M5X15	HEXAGONAL BOLT. M5X15	2	2										
5	H045704000	ESCUA. AMARRE QUEMADORES A	BURNER FASTENING BRACKET	1	1										
	Q221342000	REMACHE EXAGONAL M5	HEXAGONAL RIVET M5	4	4										
	Q152004000	TORNIL. APLASTADO M5X13 A 304	FLAT HEADED SCREW M5x13 A 3	4	4										
6	U052401000	TOBERA Ø 1,45 B.P.	NOZZLE Ø 1,45 B.P.	2	2										
6	1011600000	TOBERA Ø 2,25 G.N.	NOZZLE Ø 2,25 G.N.	2	2										
7	H505047000	DISTRIBUIDOR A QUEMADOR	DISTRIBUTOR TO BURNER	1	1										
	Q306062000	ARANDELA Ø13,9X10,33x1,5	WASHER Ø13.9X10.33x1.5	2	2										
	Q221342000	REMACHE EXAGONAL M5	HEXAGONAL RIVET M5	2	2										
	Q012032000	TORNILLO EXAGONAL M5X15	HEXAGONAL BOLT. M5X15	2	2										
8	U912102000	GRIFO VALVULA CAL 3200	VALVE TAP CAL 3200	1	1										
	U912104000	BRIDA AMARRE GRIFO 1/2"	TAP FASTENING FLANGE 1/2"	1	1										
	Q122032000	TORNILLO ALLEN M.5x15	ALLEN HEAD SCREW M.5x15	1	1										
9	U022117000	MANDO MONTADO Ø8	CONTROL BUTTON Ø8	1	1										
10	H505040000	TUBO PILOTO CPG9-05	PILOT LIGHT PIPE CPG9-05	1	1										
11	H505042000	DISTRIBUIDOR COMPL. CPG9-05	COMPL.DISTRIBUTOR CPG9-05	1											
11	H045002000	DISTRIBUIDOR COMPL. CPG9-05S	COMP. DISTRIBUTOR CPG9-05S		1										
	Q221343000	REMACHE EXAGONAL M6	HEXAGONAL RIVET M6	2	2										
	Q012042000	TORNILLO EXAGONAL M6X15	HEXAGONAL BOLT. M6X15	2	2										
	Q302022000	ARANDELA 16X6X1.2 A.304	WASHER 16X6X1.2 A.304	2	2										
	Q012032000	TORNILLO EXAGON. M5X15	HEXAGONAL BOLT. M5X15	2	2										
	Q302022000	ARANDELA 16X6X1.2 A.304	WASHER 16X6X1.2 A.304	2	2										
12	X022131000	BUJIA	SPARK PLUG	1	1										
13	U262130000	TERMOPAR 1000	THERMOCOUPLE 1000	1	1										



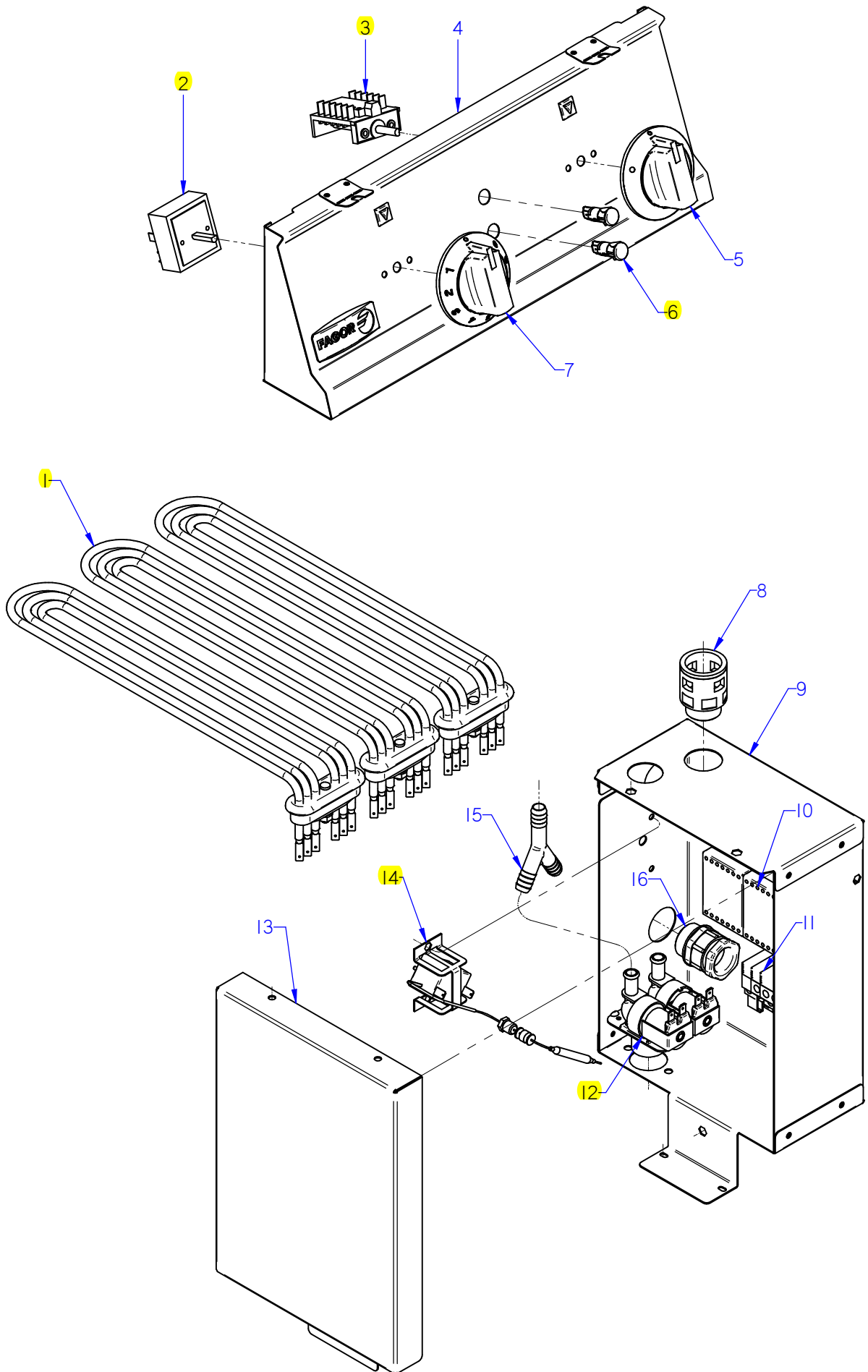

ITEM MARCADO EN COLOR = REPUESTO RECOMENDADO  
 COLOURED ITEM = RECOMMENDED SPARE PART

Nº plano / N° plane	Firma	Fecha / Date	Denominación / Denomination: FUNCIONAL ELECTRICO / FUNCTIONAL ELECTRICAL	Lamina / Sheet	agor Industrial S.Coop. <b>FAGOR</b>
C-2941	<i>(Signature)</i>	2012-03	COCED. DE PASTA CPE9-05 PLUS	5	Oñate

MOD.		COCEDOR DE PASTA / PASTA COOKER		ZONA / ZONE		PARTE FUNCIONAL ELECTRICO FUNCTIONAL ELECTRICAL PART						PLANO DIAGRAM		C-2941	
ITEM	CODIGO REFERENCE	DENOMINACION	DENOMINATION	CPE9-05 PLUS	CPE9-05 PLUS S							ELIMINADO ELIMINATED	INTRODUCID. INTRODUCED	NOTAS	
1	H063002000	RESISTENCIA 4000W 230V	RESISTOR 4000W 230V	3	3										
2	S333001000	REGULADOR DE ENERGIA	ENERGY REGULATOR	1	1										
3	R693004000	CONMUTADOR 16A 6VIA 4POS VDE	SWITCH 16A 6VIA 4POS VDE	1	1										
	Q151320000	TORNILLO ALOMADO M4X6 H.ZINC	CURVED SCREW M4X6 H.ZINC	2	2										
4	H042805000	PORTAMANDOS COMPL. CPE	CONTROL HOLDER CPE	1	1										
5	H503006000	MANDO AGUA COMP. CP900	CONTROL BUTTON WATER	1	1										
6	R693056000	PILOTO AMBAR 41227000A4	AMBER PILOT 41227000A4	1	1							01.02.13			
6	12024669	PILOTO AMBAR Ø18	AMBER PILOT Ø18	1	1								01.02.13		
S/Nº	R693055000	PILOTO VERDE 41227000C7	GREEN PILOT 41227000C7	1	1							01.02.13			
S/Nº	12047390	PILOTO VERDE 230V AC 8KW 16MM	GREEN PILOT 230V AC 8KW 16MM	1	1								01.02.13		
7	S162102000	BOTON DE MANDO	CONTROL BUTTON	1	1										
8	X713021000	RACON QUICK 5020.049.021	CONNECTION ICK 5020.049.021	4	4										
	R023025000	CONTRATUERCA (GAES)	COUNTERNUT (GAES)	4	4										
9	H042635000	CUADRO ELECTRICO CPE	ELECTRIC PANEL CPE	1	1										
	Z703006000	RACORD A 90 SFWO-P213T	CONNECTION A 90 SFWO-P213T	2	2							11.03.12			
10	Z203050000	CONTACTOR SIRIUS 3R 230V50-60	CONTACTOR SIRIUS 3R 230V50-60	2	2										
	Z403016000	GUIA CONTACTOR L-100	CONTACTOR GUIDE L-100	1	1										
	Q419005000	REMACHE 4X8 ALMG3 / ALUMINIO	RIVET 4X8 ALMG3 / ALUMINIUM	4	4										
11	P453025000	BORNA PASO 57A 10mm2 1VIA UL	TERMINAL STEP 57A 10mm2 1V	3	3										
	P453026000	BORNE TIER 10 WPE-10103.O	TERMINAL TIER 10 WPE-10103.O	1	1										
	Z263302000	BORNA NEUTRO AZUL 57A 1VIA UL	NEUTRAL TERMINAL VIA BLUE	1	1										
	Z263303000	TOPE FINAL	END STOP	1	1										
12	P255001000	ELECTRO. 230V AC 50/60Hz 2V A	SOLENOID 230V AC 50/60Hz 2V	1	1										
S/Nº	P443042000	REGULADOR 3L VERDE 254.023	REGULATOR 3L GREEN 254.023	1	1							11.11.13			
S/Nº	12097038	REGULADOR 3L NEGRO 254.023	REGULATOR 3L BLACK 254.023	1	1								11.11.13		
S/Nº	Z601156000	REGULADOR 8L RO. 254.034	REGULATOR 8L RO. 254.034	1	1							11.11.13			
S/Nº	12096626	REGULADOR 8L ROJO	REGULATOR 8L RED	1	1								11.11.13		
13	H042636000	TAPA CUADRO ELECTR. CPE	ELEC. PANEL COVER CPE	1	1										
	Q152004000	TORNIL. APLASTADO M5X13 A 304	FLAT HEADED SCREW M5x13 A 304	3	3										
14	Z213014000	TERMOSTATO SEGURIDAD 125°C	SAFETY THERMOSTAT 125°C	1	1										
	Z203060000	AMARRE LIMITADOR TECASA	LIMITER FASTENING TECASA	1	1										











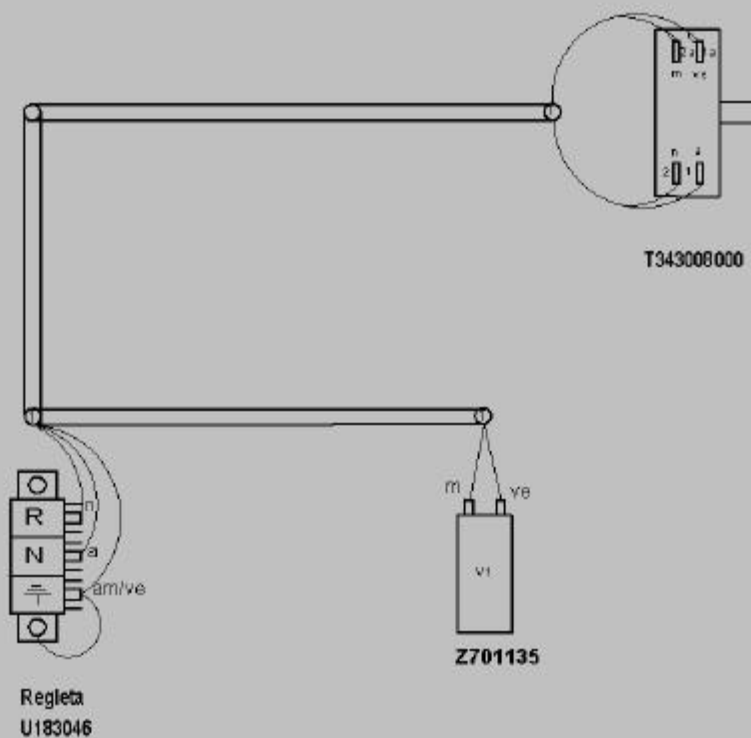



Instalazio elektriko: CPG9-05	H503001000
Instalazio elektriko: CPG9-05 S	H503002000
Eskema teoriko	H503003000

-		Muntajeko plano: CPG9-05		-		H503004000		-		
Zk. N°	Pieza	Cant.	Materiala/Material		Clas. z/N° Clas.	Gainazal akabera/Tratamiento				
Zk. N°	Aldaketak/Modificaciones		Nork proposatua/Propuesta de		Data/Fecha	Perdor erokorak Tolerancias generales				
-	-		-		-	-				
-	-		-		-	$4-5 \pm 0.2$ $50-100 \pm 0.8$ $5-25 \pm 0.4$ $>100 \pm 1$ $25-50 \pm 0.6$ $\alpha \pm 1$				
		Sinadura/Firma	Data/Fecha		Gehaziz persona Mecanizado superficial					
Monaizua/Dibujado		e. carrescal	2008-10-27		 Fagor Industrial/Koop. Elk. Mugakua					
Proiektatua/Proyectado		e. carrescal	2008-10-27							
Ekoiztetua/Comprobado		J. Ibarra	2008-10-27							
Eskala/Escala		<b>EGOSKETA</b>			Plano Zk./Plano N°					
-					HB-80506					
-					Zk. ord. du					
-		Plano hau ezin daiteke erabili, ez berretsi, gure balmenik gabe					Zk. gabik ord.			

# CPE9-05 /S

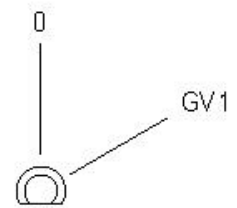
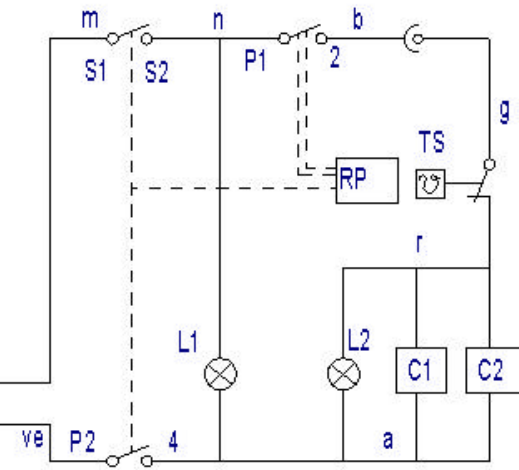
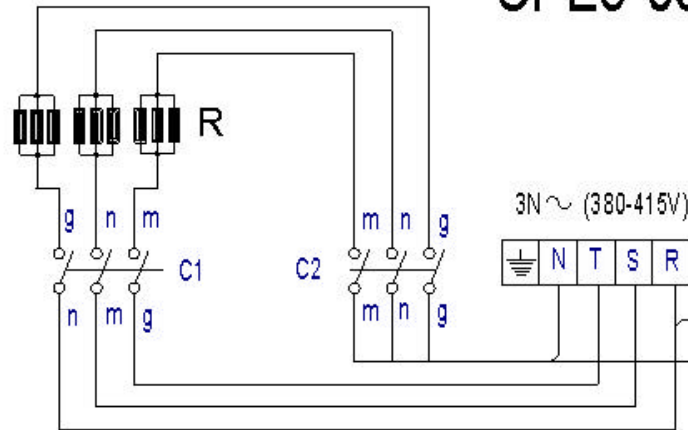

<b>IG</b>	1 1a	2 2a
0		
V1	X	X

- IG: Interruptor general
- C1, C2: Contactor de calentamiento
- L1: Lámpara funcionamiento
- L2: Lámpara calentamiento
- R: Resistencias
- RP: Regulador de energía.
- TS: Termostato Seguridad (125°)

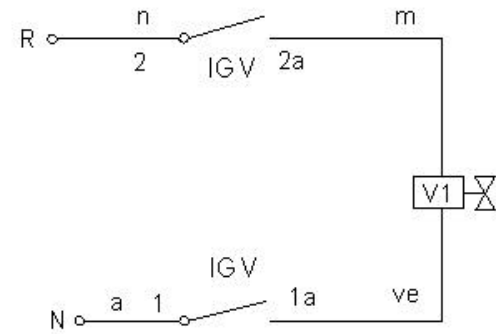
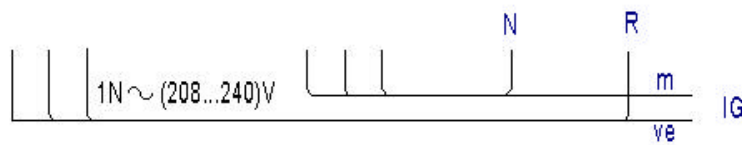
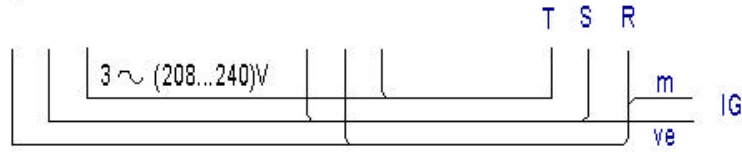
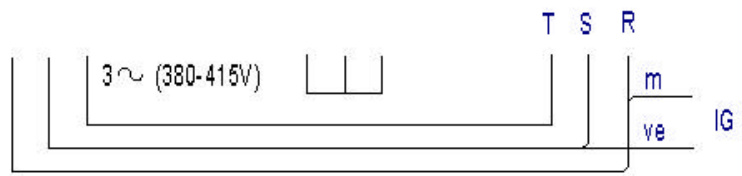

- IG = Interruptor general
- L1 = Lámpara funcionamiento
- V1 = Valvula Agua Caliente

POSICION	% ±2%	P1 - 2		P2 - 4	S1 - S2
		TON	TON+TOF		
0	0	0	∞		
52°	6%	3"	45"	X	X
84°	10%	4"	38"	X	X
116°	15%	5"	32"	X	X
148°	25%	7"	29"	X	X
180°	30%	9"	30"	X	X
212°	40%	13"	32"	X	X
244°	55%	21"	37"	X	X
276°	75%	45"	60"	X	X
308°	100%	∞	∞	X	X

-	Eskemateoria/ko: CPE9-05, CPE9-05 S		-	-	H063017000	-
Zk./Nº	Pieza	Car.t.	Materia/Material	Klas. zk./Nº Clas.	Gaituzailakabe ra/Tatam k...to	
Zk./Nº	Aldaketan/Modifikazioak		No.k proposatza/Propuesta de	Data/Fecha	Perdola orokorrak Tokirakotas generak	
-	-	-	-	-	-	-
-	-	-	-	-	± 5 ± 0.2	50 + 100 ± 0.8
-	-	-	-	-	5 + 25 ± 0.4	> 100 ± 1
-	-	-	-	-	25 + 50 ± 0.6	Cl. ± 1
-	-	-	-	-	-	-
Marrazta/Dibujado			Sinadura/Firma	Data/Fecha	Gaituzaila perdola Mecanizado superficial	
Proiektatza/Proyectado			e.carrascal	2008-10-29	-	
Egiaztatza/Comprobado			e.carrascal	2008-10-29	-	
Eskala/Escala			e. Albedi	2008-10-29	-	
 Fagor Industrial, Koop. Ek., Miragiba				<b>EGOSKETA</b>		
				Plano kate zikloa/Plano Nº HC-81137		
Plano kate zikloa/Plano Nº						Zk. ord. d1
Plano kate zikloa/Plano Nº						Zk. gaituzaila

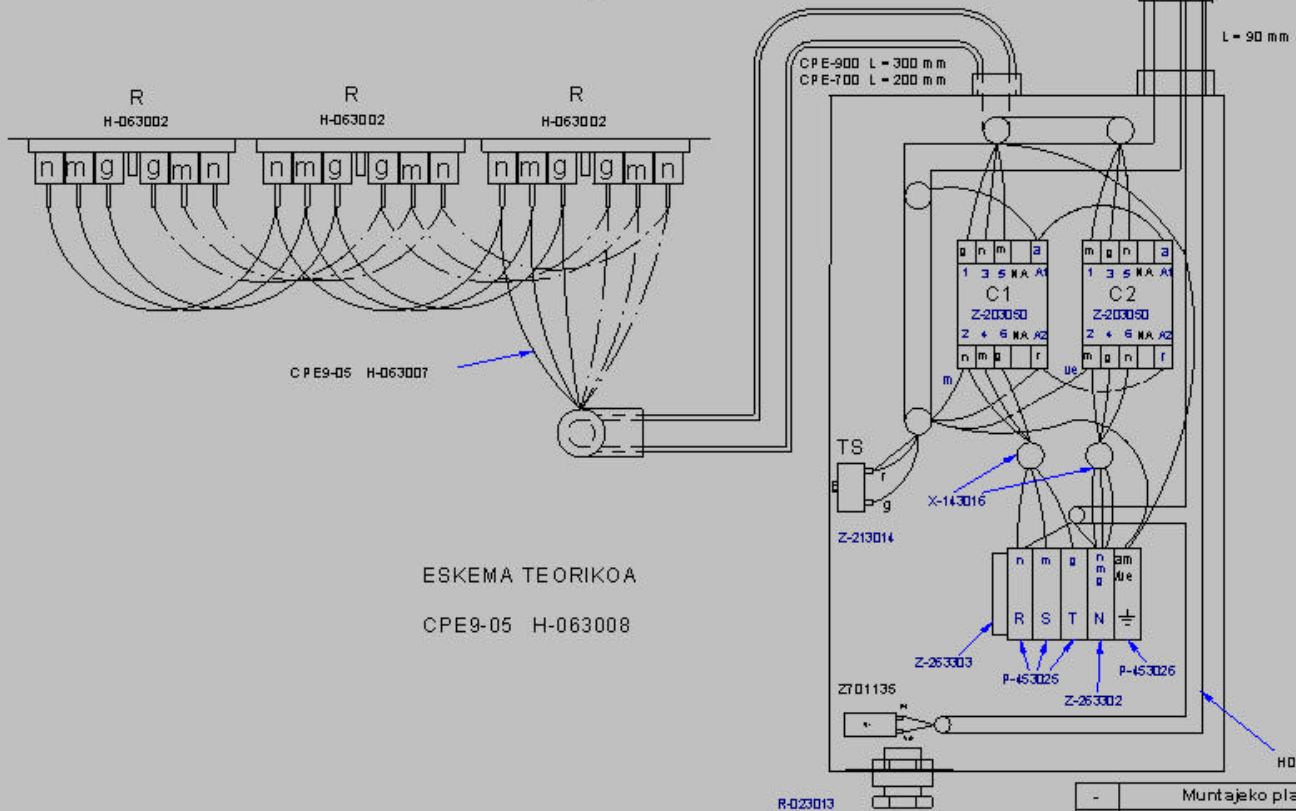
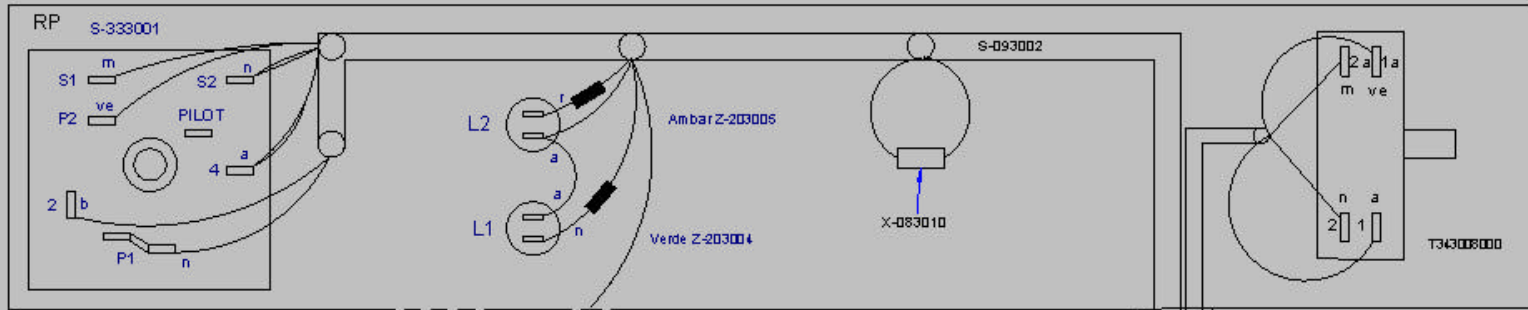

ESKEMA TEORIKOA  
CPE9-05 H-063008

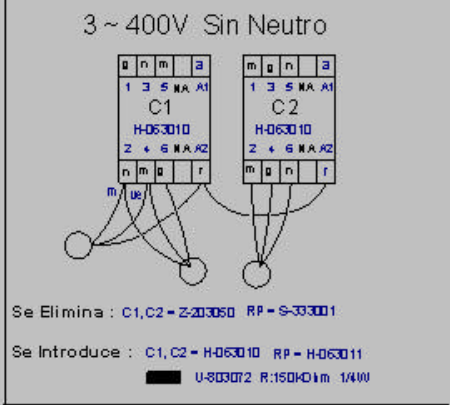
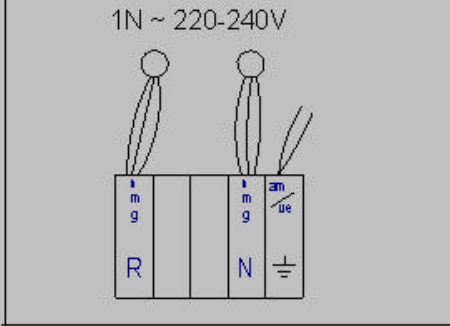
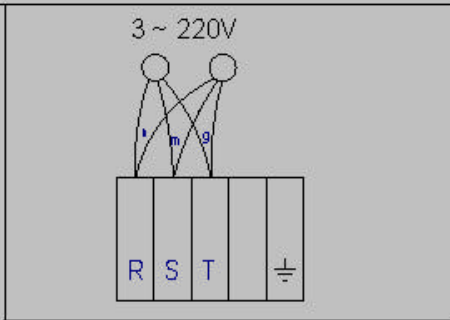
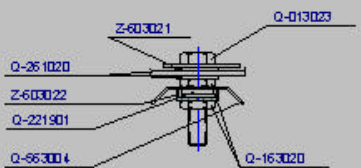

-	Muntaje plano: CPE9-05	-	-	H063015000	-	
Zk./Nº	Pieza	Cant.	Materia/Material	Klas. zk./Nº Clas	Gaitzak/akabeza/Tartam. k. r. b.	
Zk./Nº	Aldaketak/Modifikazioak	No. k. proposatua/Propuesta de	Data/Fecha		Perdola orokorrak Tolerantzia guztizkoak	
-	-	-	-	-		
-	-	-	-	-	+ 5 ± 0.2	50 + 100 ± 0.8
-	-	-	-	-	6 + 25 ± 0.4	> 100 ± 1
-	-	-	-	-	25 + 50 ± 0.6	DL ± 1
-	-	-	-	-		

	Sinadura/Firma	Data/Fecha	 Fagor Industrial, Koop. Ek., Mitigata	Gaitzak/Perdola Mecanizado superficial
Mariaztua/Dibitadua	e. carraizal	2008-10-27		
Proiektatza/Proyctado	e. carraizal	2008-10-27		
Egiaztatza/Comprobado	g. Berdute	2008-10-27		
Eskala/Escala				
<b>EGOSKETA</b>				Plano Zk./Piezo Nº HC-81135
Plano honen zehaztasun erabilgarria, ez berriketatu, gure balizko gabe.				- Zk. ord. d1
				- Zk. gaitz. ord.

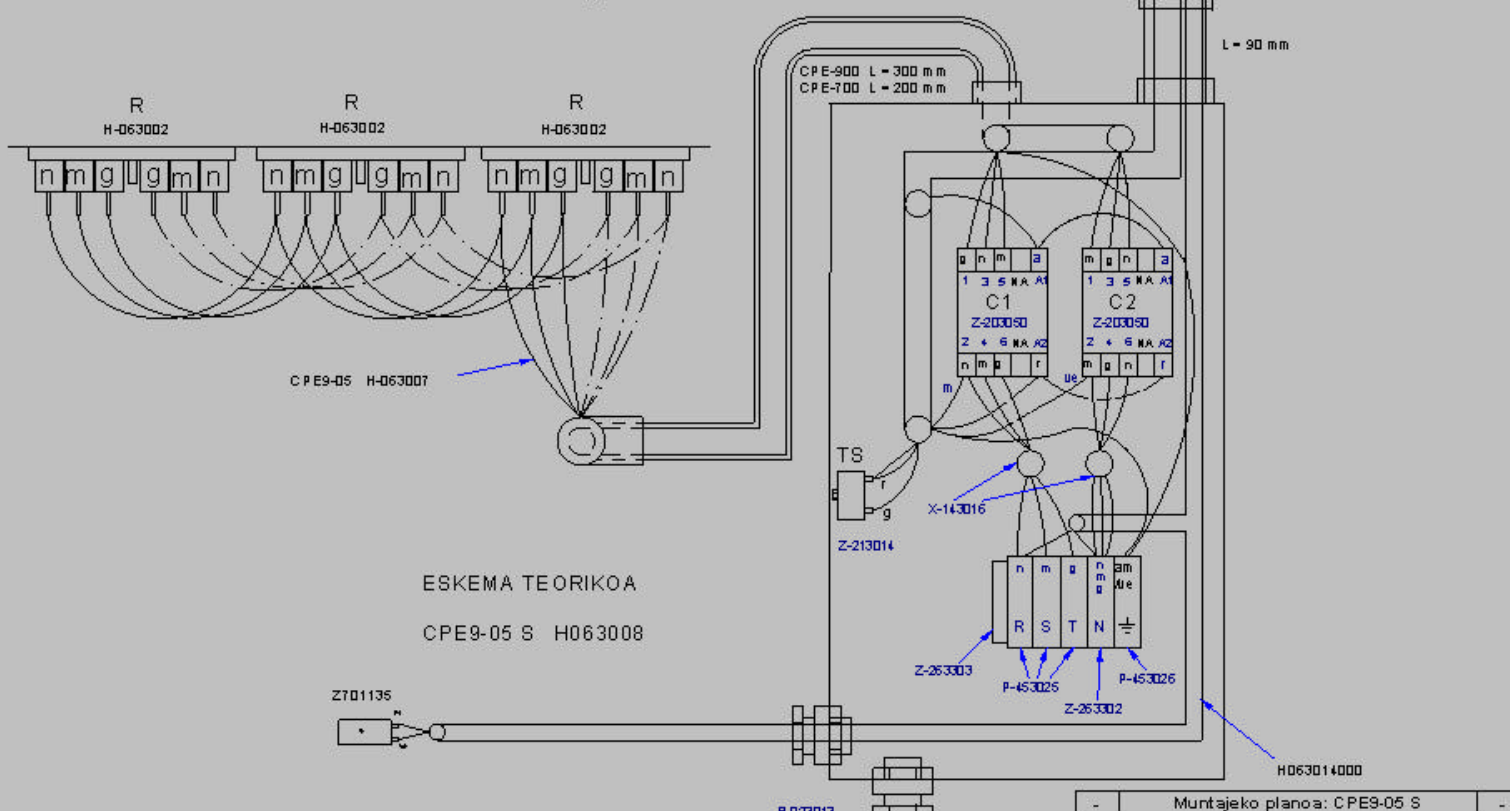
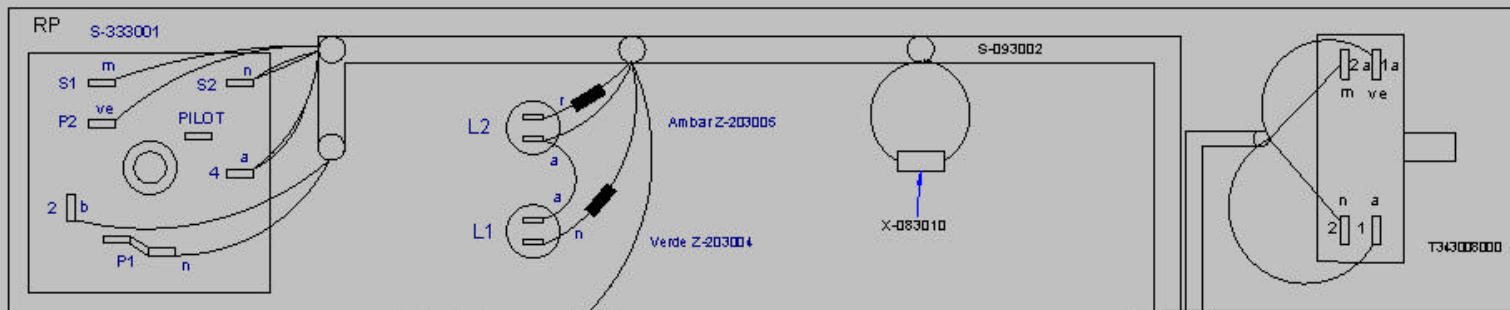

ESKEMA TEORIKOA  
CPE9-05 S H063008

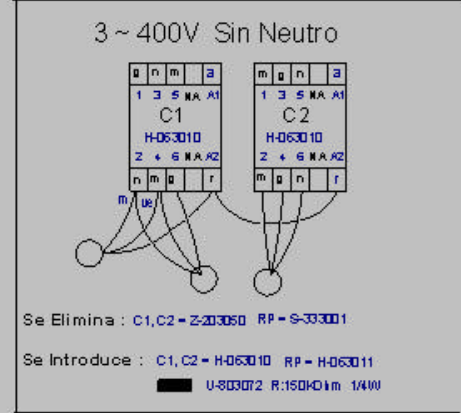
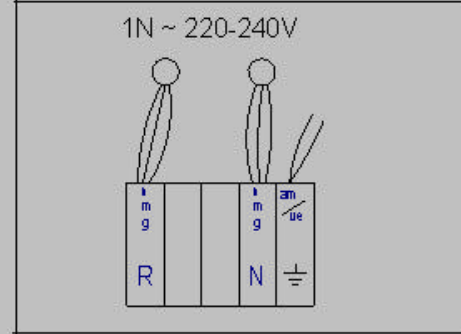
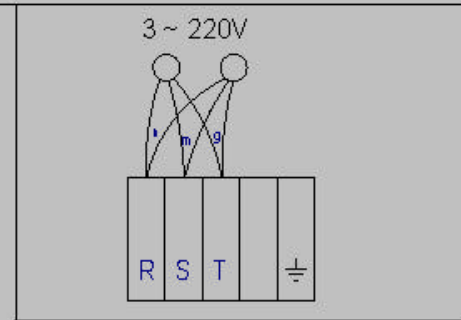
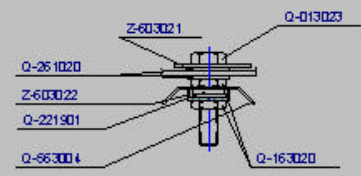

-	Muntajeko plano: CPE9-05 S	-	-	H063016000	-	
Zk./Nº	Peza	Carit.	Materia/Material	Klas. zk./Nº Clas	Gaitza/akabera/Tartam. k. r. b.	
Zk./Nº	Aldaketak/Modifikabioak	No. k. proposatua/Propuesta de	Data/Fecha		Perdola orokorra/Tolerantzia generalak	
-	-	-	-	-	+ 5 ± 0.2	SD + 100 ± 0.8
-	-	-	-	-	6 + 25 ± 0.4	> 100 ± 1
-	-	-	-	-	25 + 50 ± 0.6	DL ± 1
-	-	-	-	-	-	-

	Sinadura/Firma	Data/Fecha	 Fagor Industrial, Koop. Ek., Mitigata	Gaitza/periodo Mecanizado superficial		
Mariaztia/Dibitad	e. carraizal	2008-10-27		<b>EGOSKETA</b>	Plano Zk./Plano Nº HC-81136	
Proiektatza/Proyector	e. carraizal	2008-10-27			-	Zk. ord. d1
Egiazatza/Comprobado	g. Berdute	2008-10-27			-	Zk. gaitz. ord.
Eskala/Escala						

Plano katez eta daiteke erabili, ez berribatzi, gure balmerik gabe.