DESPIECES DEL SERVICIO TECNICO

Hornos Estáticos - Fours Statiques
Static Ovens - Kombinationsöfen

Mod.

HG9-10

HG9-20

HE9-10

HE9-20

DICIEMBRE 1999

FAGOR



Fagor Industrial, S. Coop.

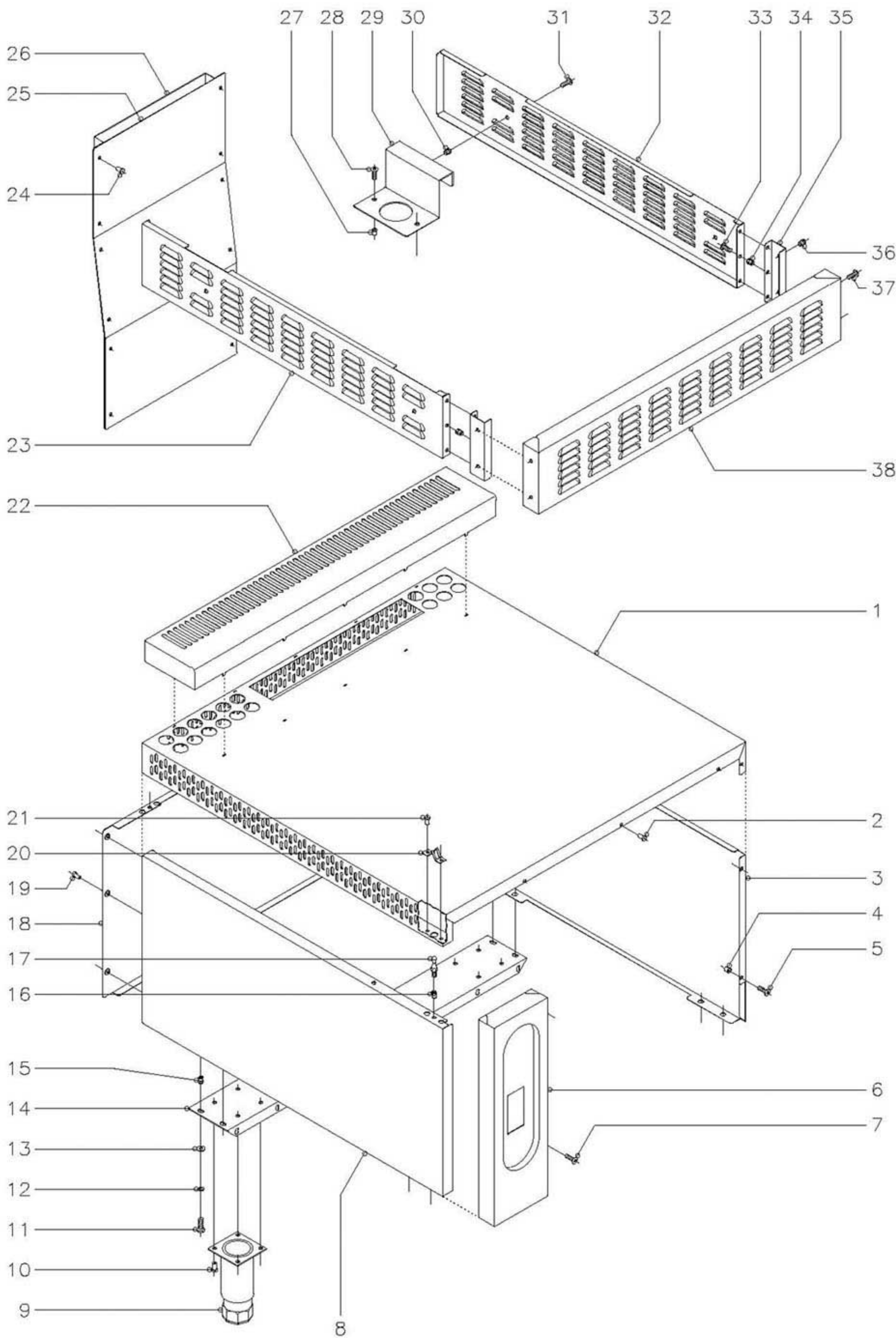

N plano
C-762

Firma
[Signature]

Fecha
12-99

Aparato
HORNOS HG9-10 Y 20
HORNOS HE9-10 Y 20

Lamina
1

Fagor Industrial S.Coop.
Ocate

FAGOR 

MOD.

HORNOS

ZONA



MUEBLE

PLANO

C-762

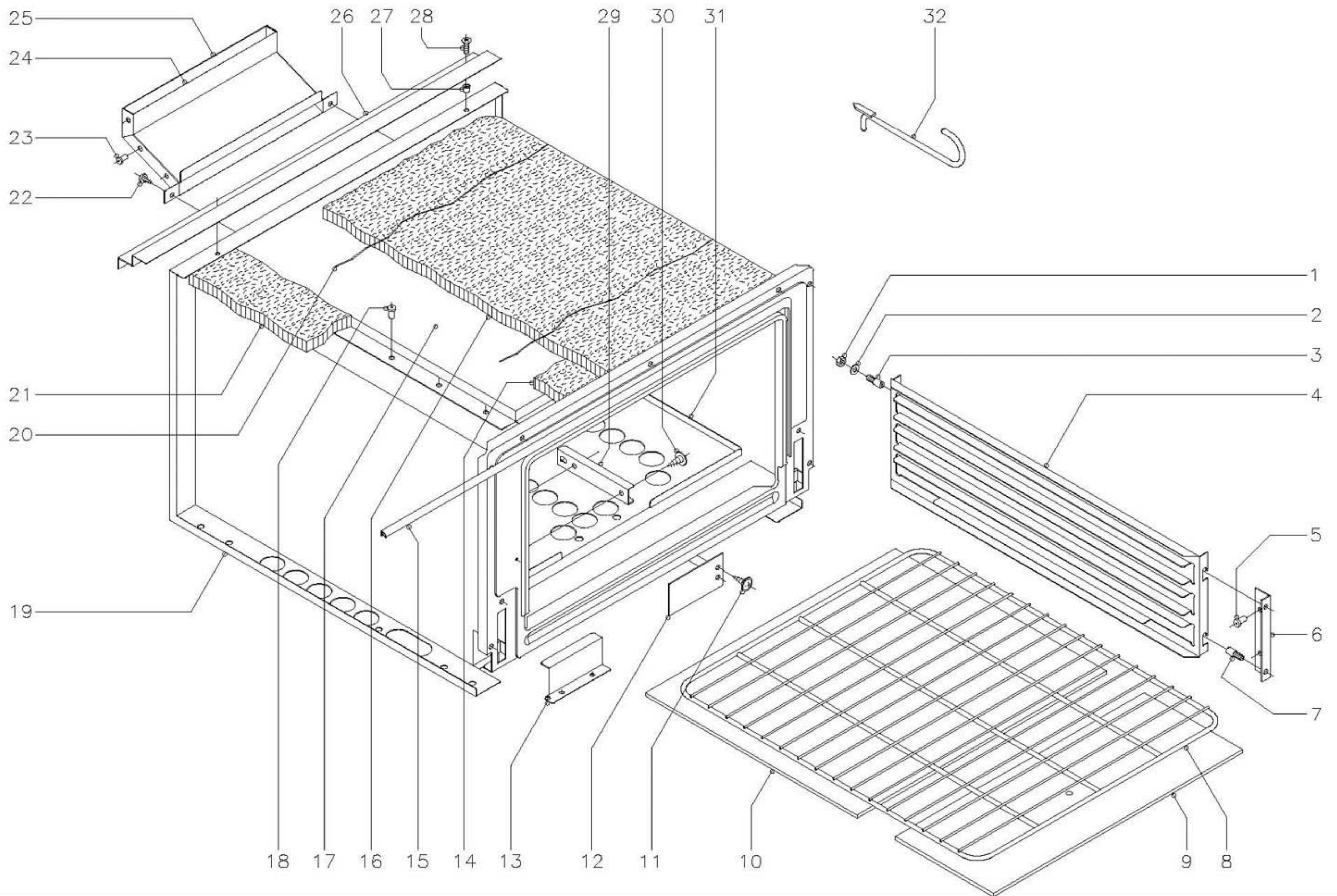
ITEM	CODIGO	DENOMINACION	TEXTO	HG9-10	HG9-20	HE9-10	HE9-20							NOTAS
1	T982803	Cubierta de horno		1	2	1	2							
2	Q419005	Remache tubular Ø 4x8		3	6	3	6							
3	T982801	Panel lateral derecho		1	2	1	2							
4	Q221304	Remache redondo M-5		3	6	3	6							
5	Q152004	Tornillo aplastado M-5x13		3	6	3	6							
6	T982805	Portamandos lateral		1	2	-	-							
6	U672852	Portamandos lateral		-	-	1	2							
7	Q152004	Tornillo aplastado M-5x13		2	4	2	4							
	Q221304	Remache redondo M-5		2	4	2	4							
8	T982800	Panel lateral izquierdo		1	2	1	2							
9	X260150	Pata regulable		4	8	4	8							
10	Q411304	Remache avibulb Ø 4,8		16	32	16	32							
11	Q012043	Tornillo exagonal M-6x20		8	16	8	16							
12	Q262040	Arandela muelle A-6		8	16	8	16							
13	Q302022	Arandela plana Ø 16xØ 6x1,2		8	16	8	16							
14	X172601	Liston soporte patas		2	4	2	4							
15	Q221343	Remache exagonal M-6		8	16	8	16							
16	Q221342	Remache exagonal M-5		3	6	3	6							
17	X012612	Piton enganche		3	6	3	6							
18	T982802	Panel posterior		1	2	1	2							
19	Q419005	Remache tubular Ø 4x8		6	12	6	12							
20	X010503	Muelle enganche piton		3	6	3	6							
21	Q419007	Remache tubular Ø 3,2x6		6	12	6	12							
22	T982806	Embellecedor chimenea		1	1	1	1							
23	T992801	Zocalo lateral izquierdo		-	1	-	1							
24	Q419005	Remache tubular Ø 4x8		-	12	-	-							
25	T992601	Suplemento anterior chimenea		-	1	-	-							
26	T992602	Suplemento posterior chimenea		-	1	-	-							
27	Q221304	Remache redondo M-5		-	8	-	8							



N plano	Firma	Fecha	Aparato	Lamina	Fagor Industrial S.Coop.	FAGOR 
C-763		12-99	HORNO HG9-10 Y 20	2	Ocate	

MOD.

HORNOS

ZONA

HORNO GAS

PLANO

C-763

ITEM	CODIGO	DENOMINACION	TEXTO	HG9-10	HG9-20														NOTAS
1	Q162040	Tuerca exagonal M-6		4	8														
2	Q302022	Arandela plana Ø 16xØ 6x1,2		4	8														
3	Q151336	Tornillo soporte guias		4	8														
4	U325608	Guia de bandejas		2	4														
5	Q419005	Remache tubular Ø 4x8		4	8														
6	U325611	Escuadra soporte guia bandejas		2	4														
7	Q151336	Tornillo soporte guias		4	8														
8	U135635	Parrilla de horno		1	2														
9	U745630	Cabeza de placa de horno		1	2														
10	U745631	Placa de horno		1	2														
11	Q151401	Tornillo alomado		2	4														
12	U325618	Tapa salida humos		1	2														
13	U742610	Protector quemador horno		1	2														
14	U745610	Aislante vitrofib 390x70x20		1	2														
15	U745626	Junta puerta horno		1	2														
16	U325621	Aislante vitrofib 1455x670x20		1	2														
17	U745613	Camara conduccion de humos		1	2														
18	Q419005	Remache tubular Ø 4x8		17	34														
19	U745620	Cuerpo de horno		1	2														
20	-	Alambre amarre aislante		2	4														
21	R660530	Aislante vitrofib 680x95x20		2	4														
22	Q081365	Tornillo alomado 4,8x19		2	4														
23	Q419005	Remache tubular Ø 4x8		6	12														
24	T985607	Anterior de chimenea		1	2														
25	T985608	Posterior de chimenea		1	2														
26	T985600	Refuerzo cubierta		1	2														
27	Q221342	Remache exagonal M-5		2	4														
28	Q152004	Tornillo aplastado M-5x13		2	4														
29	U055644	Conjunto fijacion bulbo		1	2														

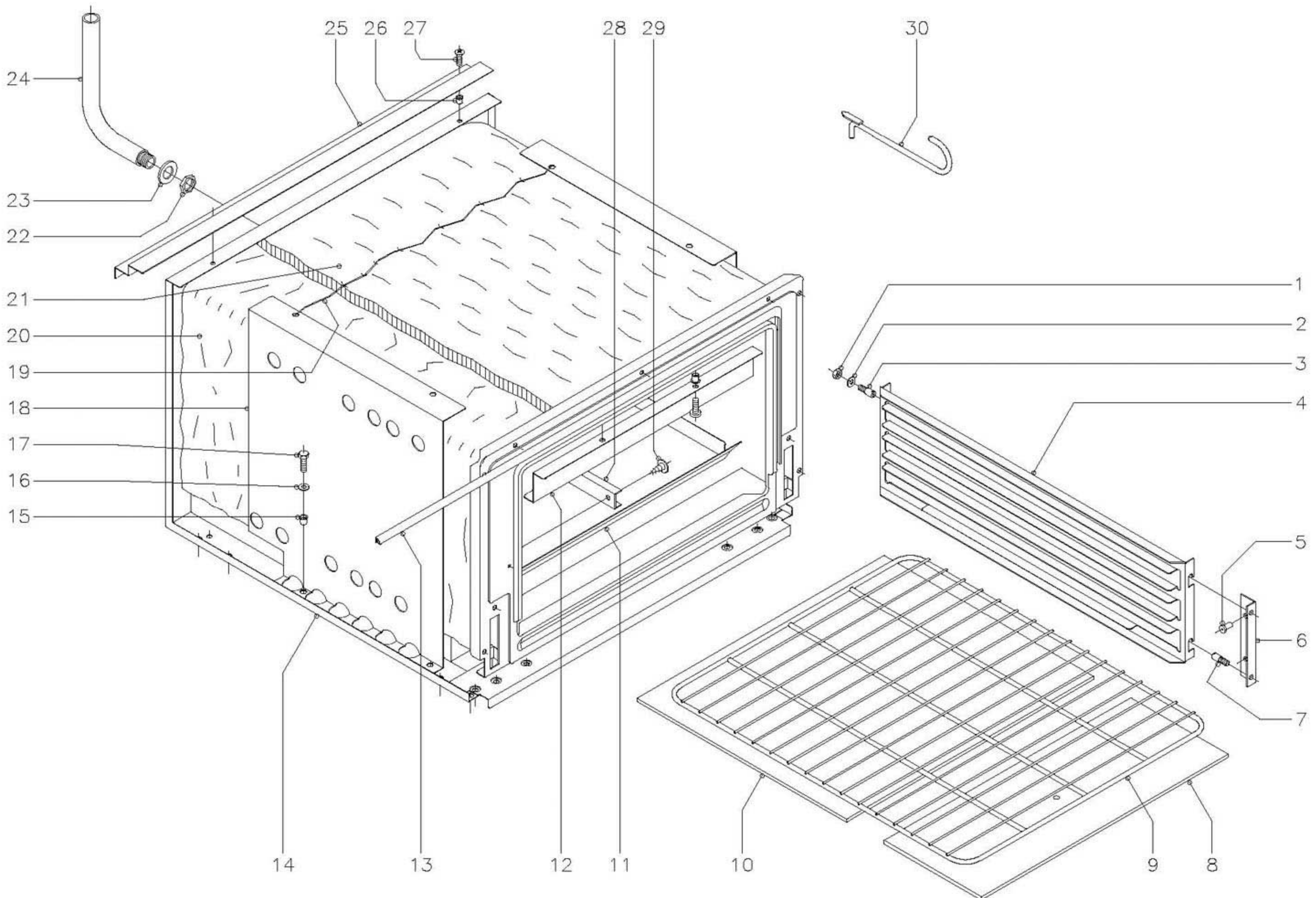

N plano	Firma	Fecha	Aparato	Lamina	Fagor Industrial S.Coop. FAGOR
C-764	<i>[Signature]</i>	12-99	HORNO HE9-10 Y 20	3	0<ate

MOD.

HORNOS

ZONA

HORNO ELECTRICO

PLANO

C-764

ITEM	CODIGO	DENOMINACION	TEXTO	HE9-10	HE9-20														NOTAS
1	Q162040	Tuerca exagonal M-6		4	8														
2	Q302022	Arandela plana Ø 16xØ 6x1,2		4	8														
3	Q151336	Tornillo soporte guias		4	8														
4	U325608	Guia de bandejas		2	4														
5	Q419005	Remache tubular Ø 4x8		4	8														
6	U325611	Escuadra soporte guia bandejas		2	4														
7	Q151336	Tornillo soporte guias		4	8														
8	U745630	Cabeza placa de horno		1	2														
9	U135635	Parrilla de horno		1	2														
10	U745631	Placa de horno		1	2														
11	U805606	Base de horno		1	2														
	Q152004	Tornillo aplastado M-5x13		4	8														
12	U805609	Amarre soporte superior		1	2														
	Q221304	Remache redondo M-5		2	4														
	Q152004	Tornillo aplastado M-5x13		2	4														
13	U745626	Junta puerta horno		1	2														
14	U805600	Cuerpo de horno		1	2														
15	Q221304	Remache redondo M-5		4	8														
16	Q302022	Arandela plana Ø 16xØ 6x1,2		4	8														
17	Q012031	Tornillo exagonal M-5x10		4	8														
18	U802601	Sujecion aislante		2	4														
19	-	Alambre sujecion aislante		2	4														
20	U325621	Aislante vitrofib 1455x670x20		1	2														
21	U805605	Aislante vitrofib 670x560x20		1	2														
22	Q221302	Tuerca exagonal 1/2"		1	2														
23	Q231311	Arandela plana A-21		1	2														
24	U675607	Tubo extractor vapores		1	2														
25	T985600	Refuerzo cubierta		1	2														
26	Q221304	Remache redondo M-5		2	4														

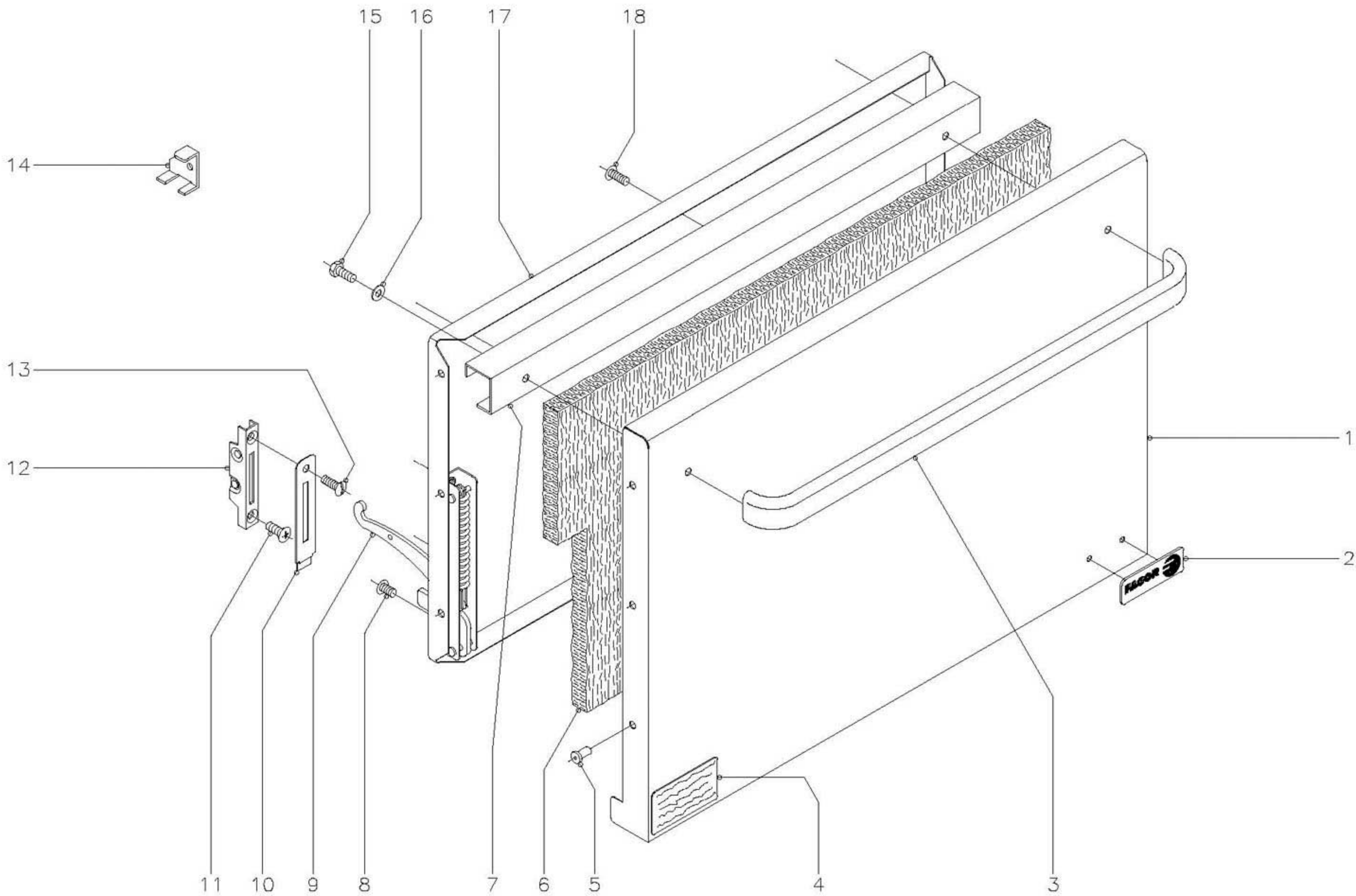

N plano
C-765

Firma
[Signature]

Fecha
12-99

Aparato
HORNOS HG9-10 Y 20
HORNOS HE9-10 Y 20

Lamina
4

Fagor Industrial S.Coop.
Olate



MOD.

HORNOS

ZONA

PUERTA HORNO

PLANO

C-765

ITEM	CODIGO	DENOMINACION	TEXTO	HG9-10	HG9-20	HE9-10	HE9-20							NOTAS
1	U740501	Puerta de horno		1	2	1	2							
2	U262806	Escudo FAGOR		1	2	1	2							
	Q221023	Clips sujecion escudo		2	4	2	4							
3	U580520	Asa de puerta		1	2	1	2							
4	S326530	Placa matricula		1	2	-	-							
4	Z206121	Placa matricula		-	-	1	2							
5	Q419005	Remache tubular Ø 4x8		6	12	6	12							
6	U260502	Aislante vitrofib 680x380x20		1	2	1	2							
7	U320507	Refuerzo de puerta		1	2	1	2							
8	Q152022	Tornillo amarre M-6x8		6	12	6	12							
9	U010511	Bisagra izquierda		1	2	1	2							
s/n	U010504	Bisagra derecha		1	2	1	2							
10	U010510	Enbellecedor guia bisagra		2	4	2	4							
11	Q042043	Tornillo avellanado M-6x20		2	4	2	4							
12	U010512	Guia de bisagra		2	4	2	4							
13	Q152017	Tornillo amarre M-6x13		2	4	2	4							
14	U746501	Escuadra montaje puerta		2	4	2	4							
15	Q012041	Tornillo exagonal M-6x10		2	4	2	4							
16	Q302022	Arandela plana Ø 16xØ 6x1,2		2	4	2	4							
17	U260501	Contrapuerta de horno		1	2	1	2							
18	Q152017	Tornillo amarre M-6x13		3	6	3	6							

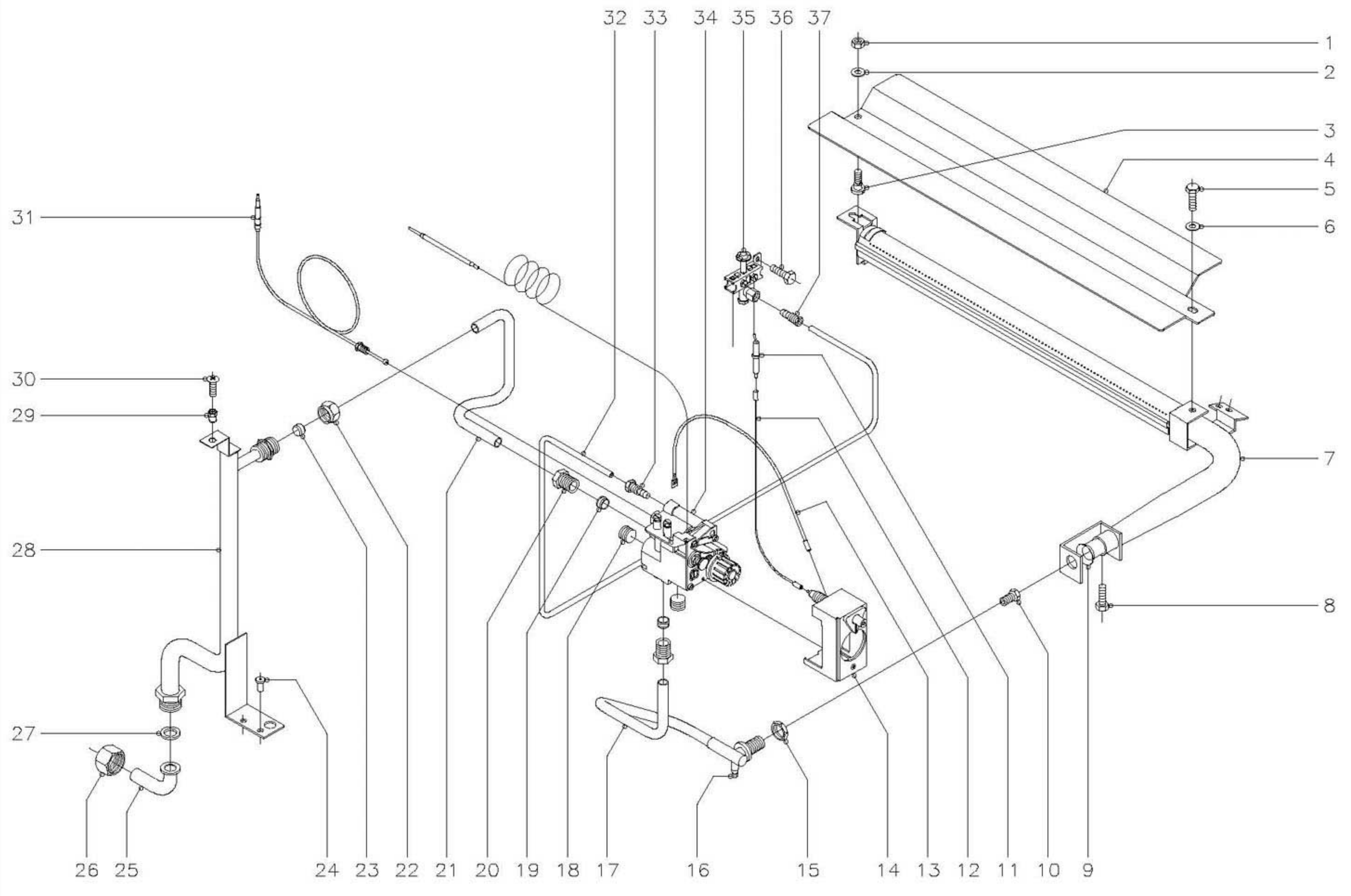

N plano C-766	Firma <i>[Signature]</i>	Fecha 12-99	Aparato HORNOS HG9-10 Y 20	Lamina 5	Fagor Industrial S.Coop. FAGOR 
------------------	-----------------------------	----------------	-------------------------------	-------------	---

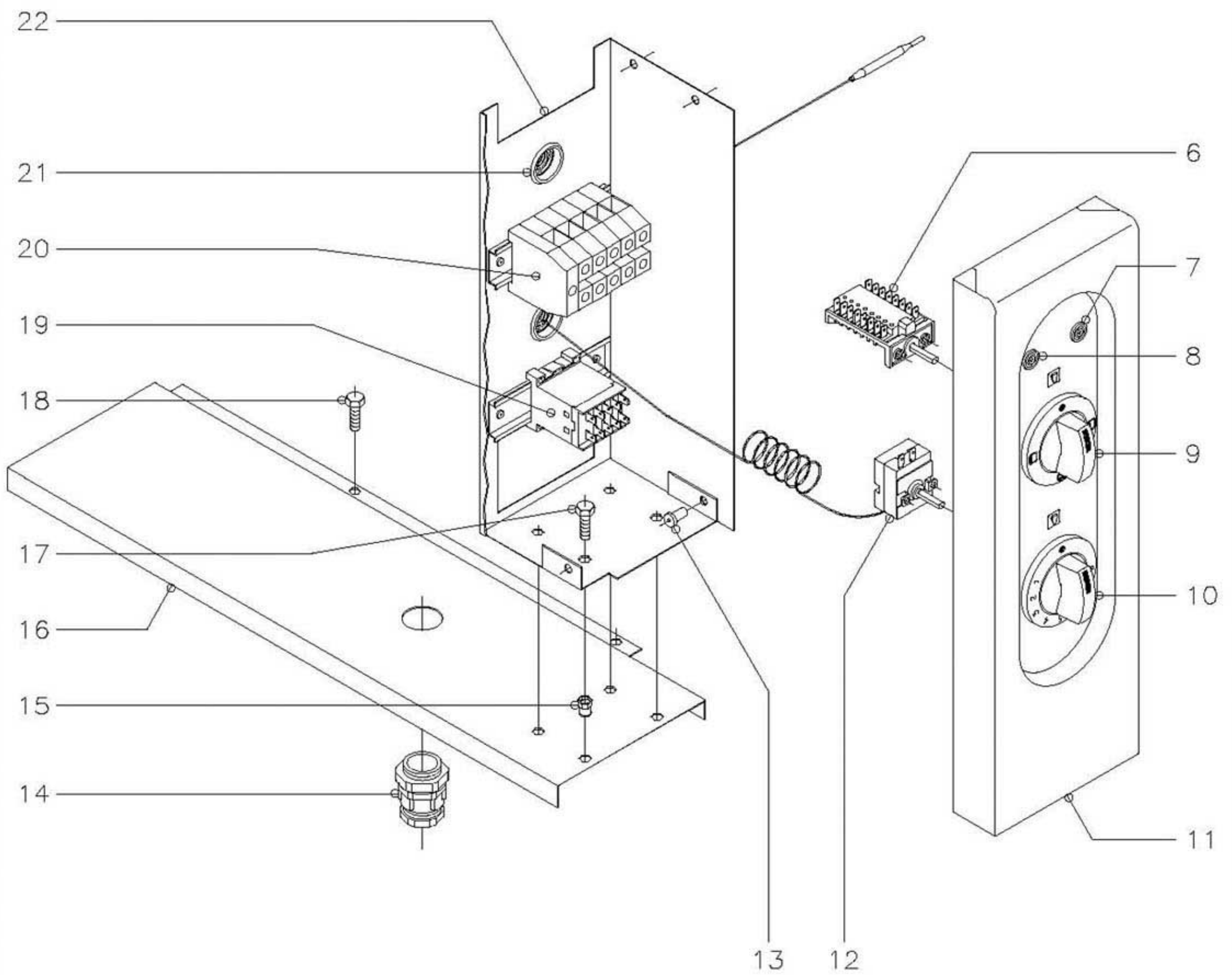
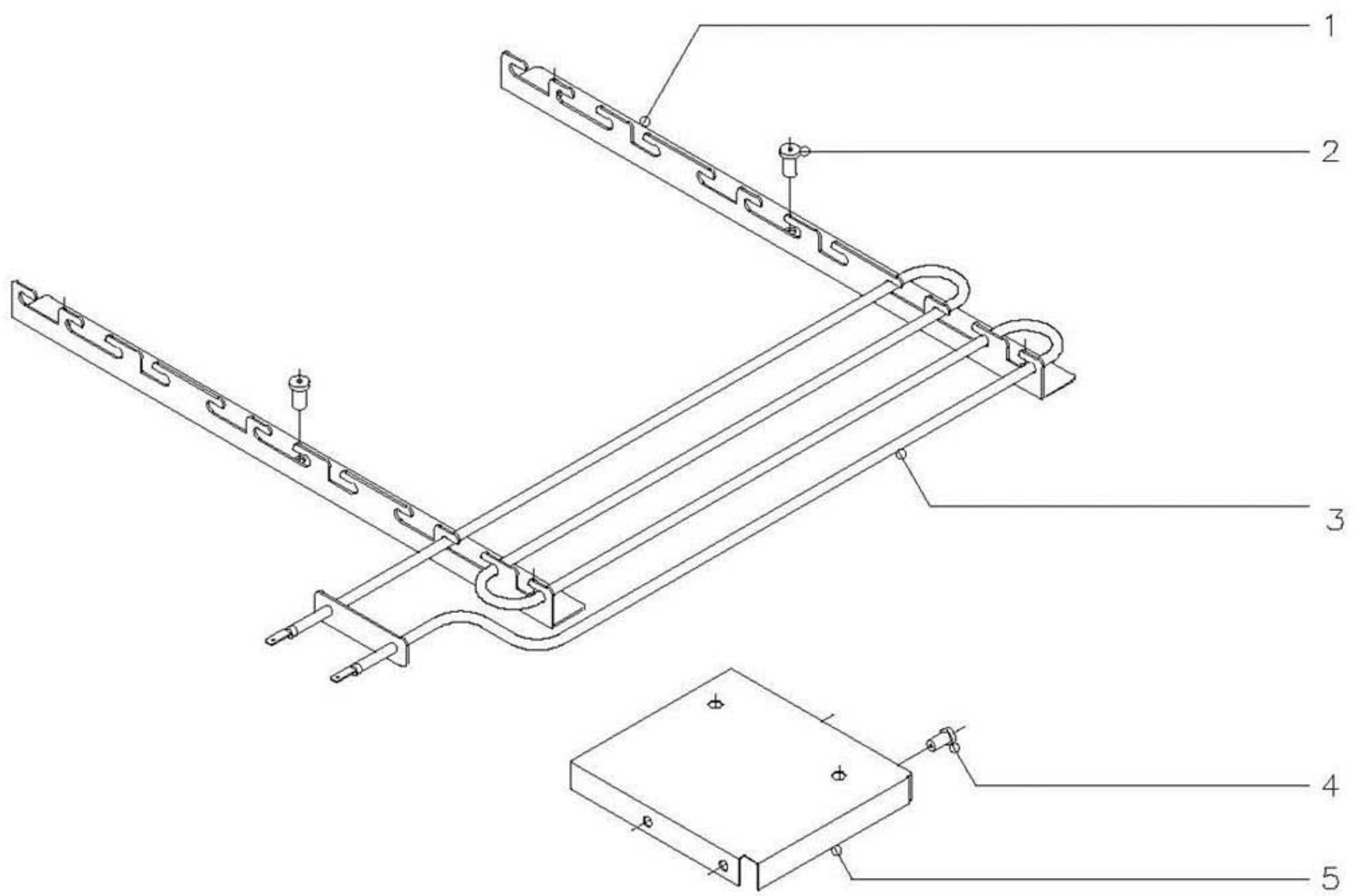

MOD.

HORNOS

ZONA

PARTE FUNCIONAL ELECTRICA

PLANO

C-767

ITEM	CODIGO	DENOMINACION	TEXTO	HE9-10	HE9-20									NOTAS
1	U805613	Escuadra soporte resistencias		4	8									
2	Q419005	Remache tubular Ø 4x8		12	24									
3	U803004	Resistencia 1000 W. , 230 V.		6	12									
4	Q419005	Remache tubular Ø 4x8		4	8									
5	U673051	Tapa de cuadro electrico		1	2									
6	U673006	Conmutador		1	2									
7	Z203005	Piloto ambar		1	2									
8	Z203004	Piloto verde		1	2									
9	U673004	Boton de mando Ø 6		1	2									
10	U673005	Boton de mando Ø 6		1	2									
11	U672852	Portamandos lateral		1	2									
12	X153000	Termostato 50-310° C.		1	2									
13	Q419005	Remache tubular Ø 4x8		2	4									
14	R023013	Prensaestopas		1	2									
15	Q221342	Remache exagonal M-5		4	8									
16	U672650	Proteccion inferior resistencias		1	2									
17	Q012031	Tornillo exagonal M-5x10		4	8									
18	Q012031	Tornillo exagonal M-5x10		2	4									
19	Z213007	Contactador 230 V. , 50/60 Hz.		1	2									
	R663055	Guia contactor L=120		1	2									
20	P453025	Borna gris de 10 (fases)		3	6									
	U803009	Borna azul de 10 (neutro)		1	2									
	P453026	Borna amarillo-verde de 10 (tierra)		1	2									
	Z263303	Tope final		1	2									
	R663055	Guia contactor L=120		1	2									
21	X723014	Pasamuros Ø 30		2	4									
22	T963000	Cuadro electrico		1	2									

MOD.

HORNOS

ZONA

PIEZAS ESPECIFICAS PARA LOS DISTINTOS GASES

PLANO

C-766

ITEM	CODIGO	DENOMINACION	TEXTO	HG9-10	HG9-20														NOTAS
		<u>BUTANO-PROPANO</u>																	
10	U052401	Tobera Ø 1,45		1	2														
	U136501	Indicador (Butano-Propano)		1	2														
		<u>GAS NATURAL</u>																	
10	9101160	Tobera Ø 2,25		1	2														
	U134402	Indicador (Gas natural)		1	2														
		<u>GAS VILLA</u>																	
10	9424600	Tobera Ø 4,23		1	2														
	U134310	Indicador (Gas villa)		1	2														

NOTAS

- Fondo: color natural
- Inscripcion letra y recuadro en color negro.
- El sello sera autoadhesivo por la cara posterior y recubierto por un papel protector.
- Las inscripciones resistiran sin modificacion apreciable el frotamiento durante 15 seg. de un algodón impregnado en gasolina.
- Medidas 127x225mm.
- Material: Papel blanco alto brillo

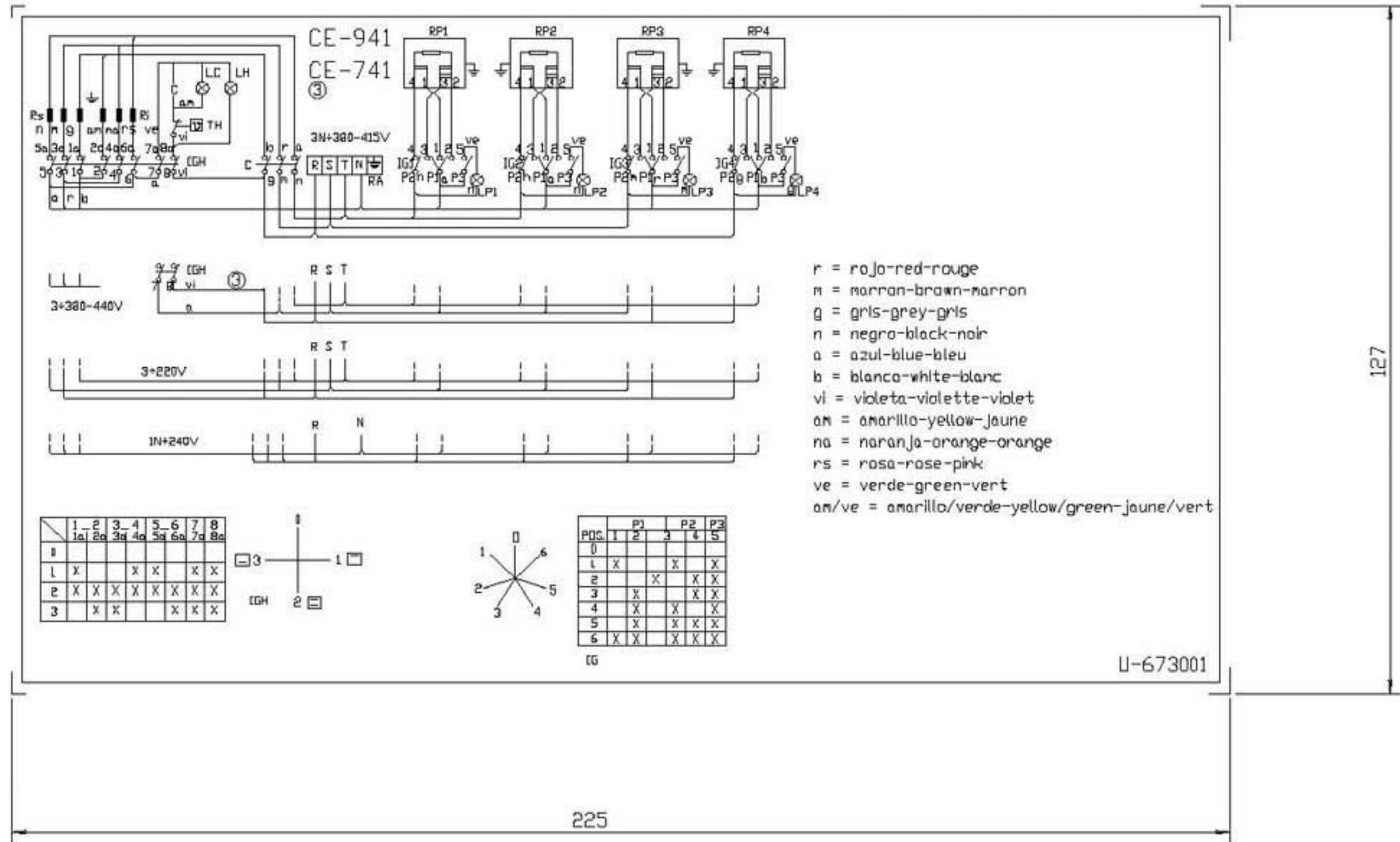

RA: Regleta de Alimentacion
 IGH: Conmutador General Horno
 C: Contactor
 LC: Lampara Calentamiento Horno
 LH: Lampara Horno Encendido
 TH: Termostato de Horno
 Rs: Resistencia Horno Superior
 Ri: Resistencia Horno Inferior
 IG,IG2,IG3,IG4: Conmutadores de placas electricas
 RP1,RP2,RP3,RP4: Placas electricas
 LP1,LP2,LP3,LP4: Lampara Calentamiento de Placas
 TFR: Transformador

Esquema teorico adhesivo			U-673001	4	
Nº	Pieza	Cont.	Material	Nº Clasificacion	Acabado
Nº	Modificacion	Propuesta de		Fecha	Tolerancias generales
①	Introducir colores	Maillo		95-5-18	< 5 ± 5 ÷ 25 25 ÷ 50 50 ÷ 100 > 100 X 1
②	Modifi.general(pasar a fabri.interior)	Plazaola		97-4-29	
③	Introducir CE-741	Maillo		97-7-2	
Dibujado		Firma	Fecha	FAGOR Fagor Industrial, Koop. Elk., Mugatua	
Proyectado		JDN	95-3-30		
Comprobado		Letang			
Escala		1/1			Plano numero
		COCINAS			HC-71190 -3
		Plano hau ez daitake erabil ez berrizta gure bolnenitz gabe			Sustituye al Nº
					Sustituida por

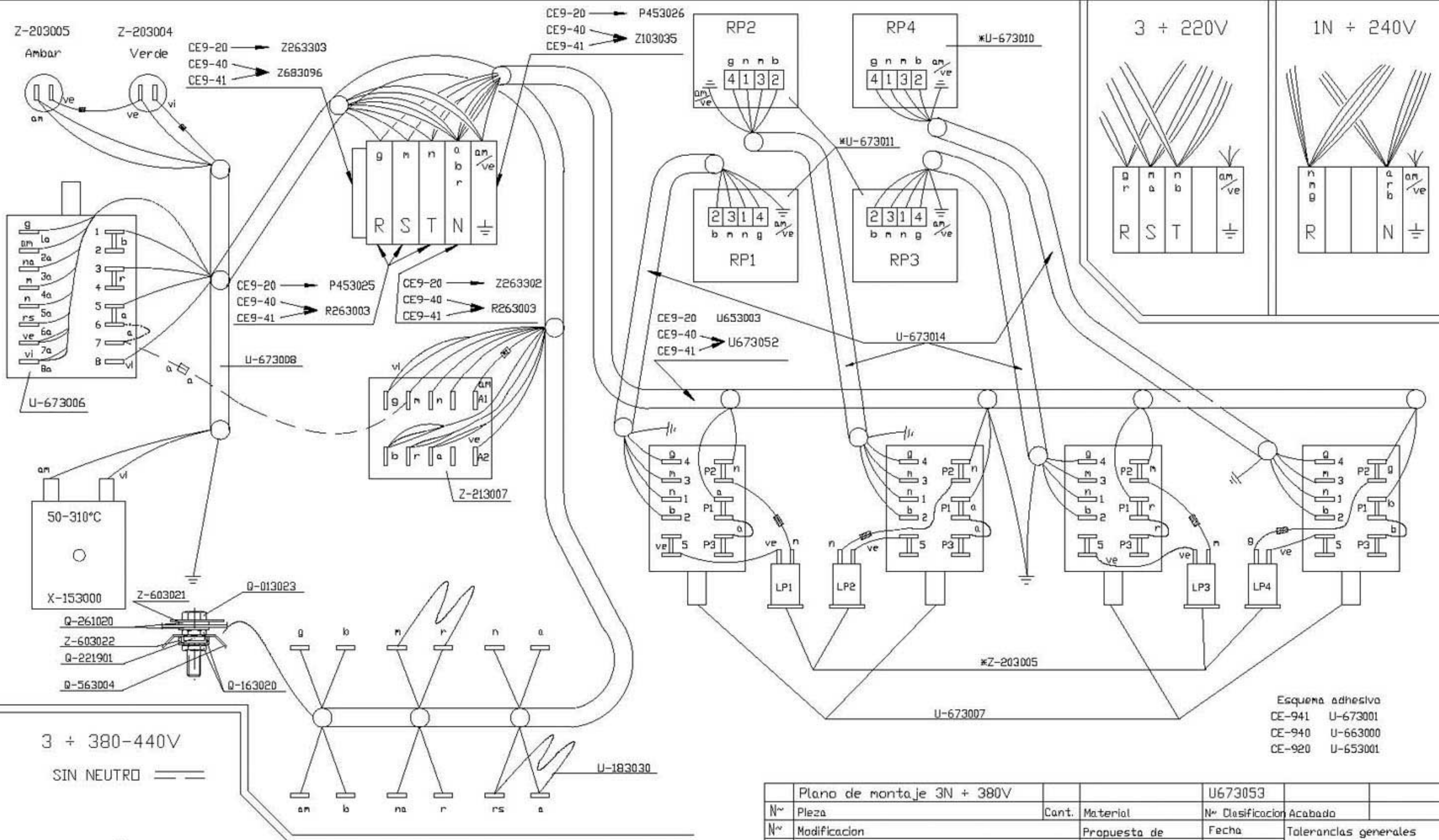

3 + 380-440V
SIN NEUTRO

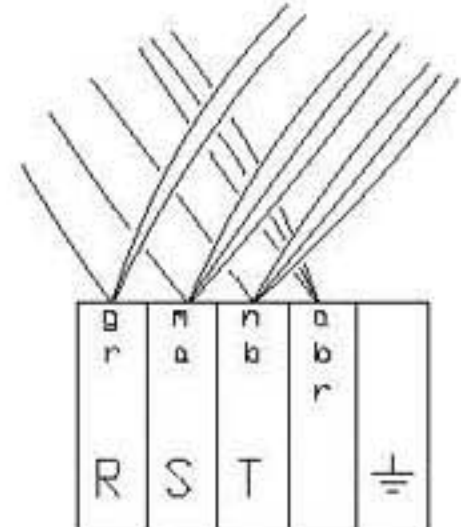

- == Versi6n sin Neutro
- U-803073 R:8K2# 6W
- U-803072 R:150K# 1/4W
- * RP1, RP2, RP3 : U-673012
- * RP4 : U-673013

Esquema adhesivo
CE-941 U-673001
CE-940 U-663000
CE-920 U-653001

Plano de montaje 3N + 380V		U673053				
Nº	Pieza	Cant.	Material	Nº Clasificaci6n	Acabado	
Nº	Modificaci6n	Propuesta de		Fecha	Tolerancias generales	
					< 5 ±	50 ± 100
					5 ± 25	> 100
					25 ± 50	OX I
Dibujado		Fecha				
Proyectado		01-12-98				
Comprobado						
Escala		Fagor Industrial, Koop. Elk. Mugatua		Mecanizada superficial		
COCINAS CE9-XX (remodelada)					Plano numero HC-73750	
Plano hau ez daiteke erabili, ez berrizta gure balerantz gabe					Sustituye al Nº	
					Sustituido por	