

---

DESPIECE TECNICO

---

**Cocina de inducción  
Induction ranges  
Fourneaux induction  
Induktion-herde  
Cucine induzione  
Fogões indução**

**GAMA 900**

**Modelos:**

**CI9-20 AD**

**CI9-40 AD**

***Marzo 01/03/2011 March***

***Revisado Octubre 2011 October Revised***

**FAGOR** 

---

F A G O R I N D U S T R I A L

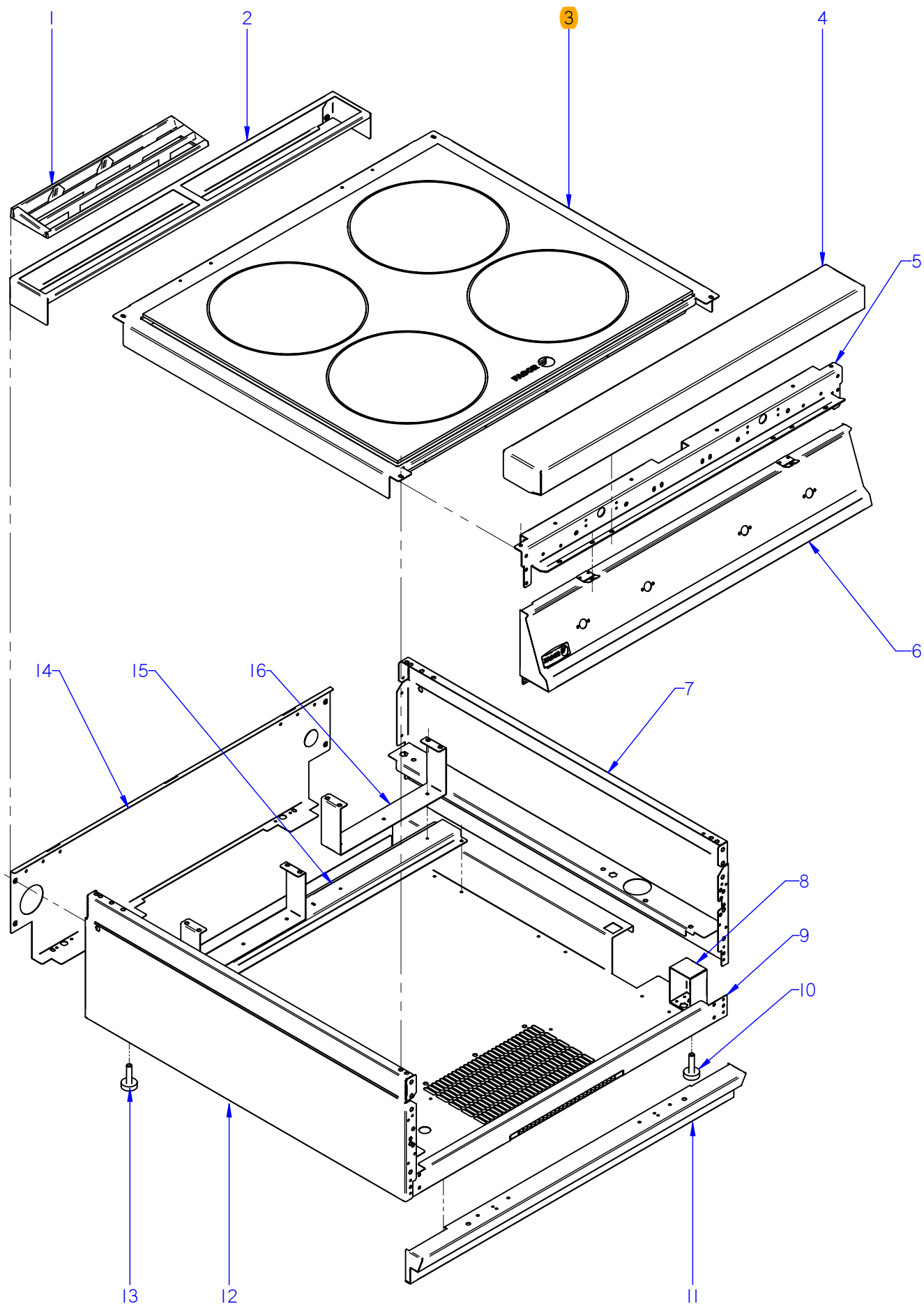

ITEM MARCADO EN COLOR = REPUESTO RECOMENDADO  
 COLOURED ITEM = RECOMMENDED SPARE PART

Nº plano / N° plane	Firma	Fecha / Date	Denominación / Denomination:	MUEBLE / FITTING	Lamina / Sheet	FAGOR
C-2693	<i>[Signature]</i>	2011-03	COCINA / RANGES CI9-20 AD / CI9-40 AD		1	FAGOR INDUSTRIAL

MOD.		COCINAS / RANGES	ZONA / ZONE	MUEBLE / FITTING							PLANO DIAGRAM	C-2693	
ITEM	CODIGO REFERENCE	DENOMINACION	DENOMINATION	C19-20 AD	C19-40 AD						ELIMINADO ELIMINATED	INTRODUCID. INTRODUCED	NOTAS
1	R205425000	EMBELLECEDOR ESMALTE	ENAMEL TRIM	1	2								
2	R205438000	SOPORTE EMBELLECEDOR 1/2M	1/2M TRIM SUPPORT	1	-								
2	R205439000	SOPORTE EMBELLECEDOR 1M	TRIM SUPPORT 1M	-	1								
	Q419005000	REMACHE 4X8 ALMG3 / ALUMINIO	RIVET 4X8 ALMG3 / ALUMINIUM	2	2								
3	U175410000	ENCIMERA COMPLETA CI9-20	TOP CI9-20 COMPL.	1	-								
3	U175409000	ENCIMERA COMPLETA CI9-40	TOP CI9-40 COMPL.	-	1								
	Q012032000	TORNILLO EXAGONAL M5x15 A304	HEXAGONAL BOLT M5x15	6	6								
4	R045416000	ANTERIOR DE MESA 1/2 M	BENCH FRONT 1/2 M	1	-								
4	S105402000	ANTERIOR MESA 1 M	BENCH FRONT 1 M	-	1								
	Q152004000	TORNIL, APLASTADO M5x13 A304	FLAT HEADED BOLT M5x13 A304	2	2								
	Q302022000	ARANDELA 16x6x1,2 A304	WASHER 16x6x1,2 A304	2	2								
5	R042611000	ESCUADRA INTER. DE MESA 1/2M	INTER BRACKET. TABLE 1/2M	1	-								
5	U172618000	ESCUADRA INTER. DE MESA 1M	INTER BRACKET. TABLE 1 M	-	1								
	Q221342000	REMACHE EXAGONAL M5	HEXAGONAL RIVET M5	4	4								
	Q012032000	TORNILLO EXAGONAL M5x15 A304	HEXAGONAL BOLT M5x15	6	6								
	Q302022000	ARANDELA 16x6x1,2 A304	WASHER 16x6x1,2 A304	4	4								
	Q419005000	REMACHE 4x8 ALMG3 / ALUMINIO	RIVET 4X8 ALMG3 / ALUMINIUM	7	7								
	Q221341000	REMACHE EXAGONAL M4	HEXAGONAL RIVET M4	1	1								
	Q221345000	REMACHE EXAGONAL M10	HEXAGONAL RIVET M10	8	8								
6	U172815000	PORTAMANDOS CI9-20	CONTROL HOLDER CI9-20	1	-								
6	U172808000	PORTAMANDOS CI9-40	CONTROL HOLDER CI9-40	-	1								
	U022836000	ESCUDO FAGOR	FAGOR EMBLEM	1	1								
	Q221023000	CLIP SUJECIÓN RÁPIDA Ø5	RAPID CONNECT CLIP Ø5	2	2								
	Q152004000	TORNIL, APLASTADO M5x13 A304	FLAT HEADED BOLT M5x13 A304	2	2								
7	R062810000	PANEL LATERAL DERECHO	RIGHT SIDE PANEL	1	1								
	Q221343000	REMACHE EXAGONAL M6	HEXAGONAL RIVET M6	5	5								
	Q221342000	REMACHE EXAGONAL M5	HEXAGONAL RIVET M5	7	7								
8	U962627000	ESCUADRA AMARRE PATA AD	LEG FASTENING BRACKET AD	2	2								
	Q162030000	TUERCA EXAGONAL M5	HEXAGONAL NUT M5	4	4								
	Q302022000	ARANDELA 16x6x1,2 A304	WASHER 16x6x1,2 A304	4	4								
	X010503000	CIERRE MUELLE	LOCK SPRING	2	2								

MOD.	COCINAS / RANGES		ZONA / ZONE	MUEBLE / FITTING							PLANO DIAGRAM	C-2693	
ITEM	CODIGO REFERENCE	DENOMINACION	DENOMINATION	C19-20 AD	C19-40 AD						ELIMINADO ELIMINATED	INTRODUCID. INTRODUCED	NOTAS
9	U172627000	BASE COMPLETA CI9-05	COMPLETE BASE CI9-05	1	-								
9	U172628000	BASE COMPLETA CI9-40	COMPLETE BASE CI9-40	-	1								
	Q419005000	REMACHE 4x8 ALMG3 / ALUMINIO	RIVET 4X8 ALMG3 / ALUMINIUM	12	12								
10	Z200107000	PATA REGULABLE	ADJUSTABLE LEG	2	2								
11	R062805000	ZOCALO COMPLETO 1/2M	COMPLETE SKIRTING 1/2M	1	-								
11	H352817000	ZOCALO COMPLETO	COMPLETE SKIRTING	-	1								
	Q151336000	TORNILLO SOPORTE GUIAS	TORNILLO SOPORTE GUIAS	2	2								
	Q221343000	REMACHE EXAGONAL M6	HEXAGONAL RIVET M6	2	2								
	Q152004000	TORNIL, APLASTADO M5x13 A304	FLAT HEADED BOLT M5x13	2	2								
	Q302022000	ARANDELA 16x6x1,2 A304	WASHER 16x6x1,2 A304	2	2								
12	R062811000	PANEL LATERAL IZQUIERDO	LEFT SIDE PANEL	1	1								
	Q221343000	REMACHE EXAGONAL M6	HEXAGONAL RIVET M6	5	5								
	Q221342000	REMACHE EXAGONAL M5	HEXAGONAL RIVET M5	7	7								
13	Z200107000	PATA REGULABLE	ADJUSTABLE LEG	2	2								
14	R042838000	PANEL POSTERIOR 1/2M AD	REAR PANEL 1/2M AD	1	-								
14	U042805000	PANEL POSTERIOR 1M AD	REAR PANEL 1M AD	-	1								
	Q419005000	REMACHE 4x8 ALMG3 / ALUMINIO	RIVET 4X8 ALMG3 / ALUMINIUM	4	4								
	Q152004000	TORNIL, APLASTADO M5x13 A304	FLAT HEADED BOLT M5x13 A304	2	2								
	X010503000	CIERRE MUELLE	LOCK SPRING	2	2								
15	U172612000	SOPORTE OMEGA CI9-20	OMEGA CI9-20 SUPPORT	2	-								
15	U172613000	SOPORTE OMEGA CI9-40	OMEGA CI9-40 SUPPORT	-	2								
	Q419005000	REMACHE 4x8 ALMG3 / ALUMINIO	RIVET 4X8 ALMG3 / ALUMINIUM	8	8								
16	U172609000	SOPORTE CARRIER	CARRIER SUPPORT	2	4								
	Q419005000	REMACHE 4x8 ALMG3 / ALUMINIO	RIVET 4X8 ALMG3 / ALUMINIUM	4	8								
	Q221342000	REMACHE EXAGONAL M5	HEXAGONAL RIVET M5	4	8								

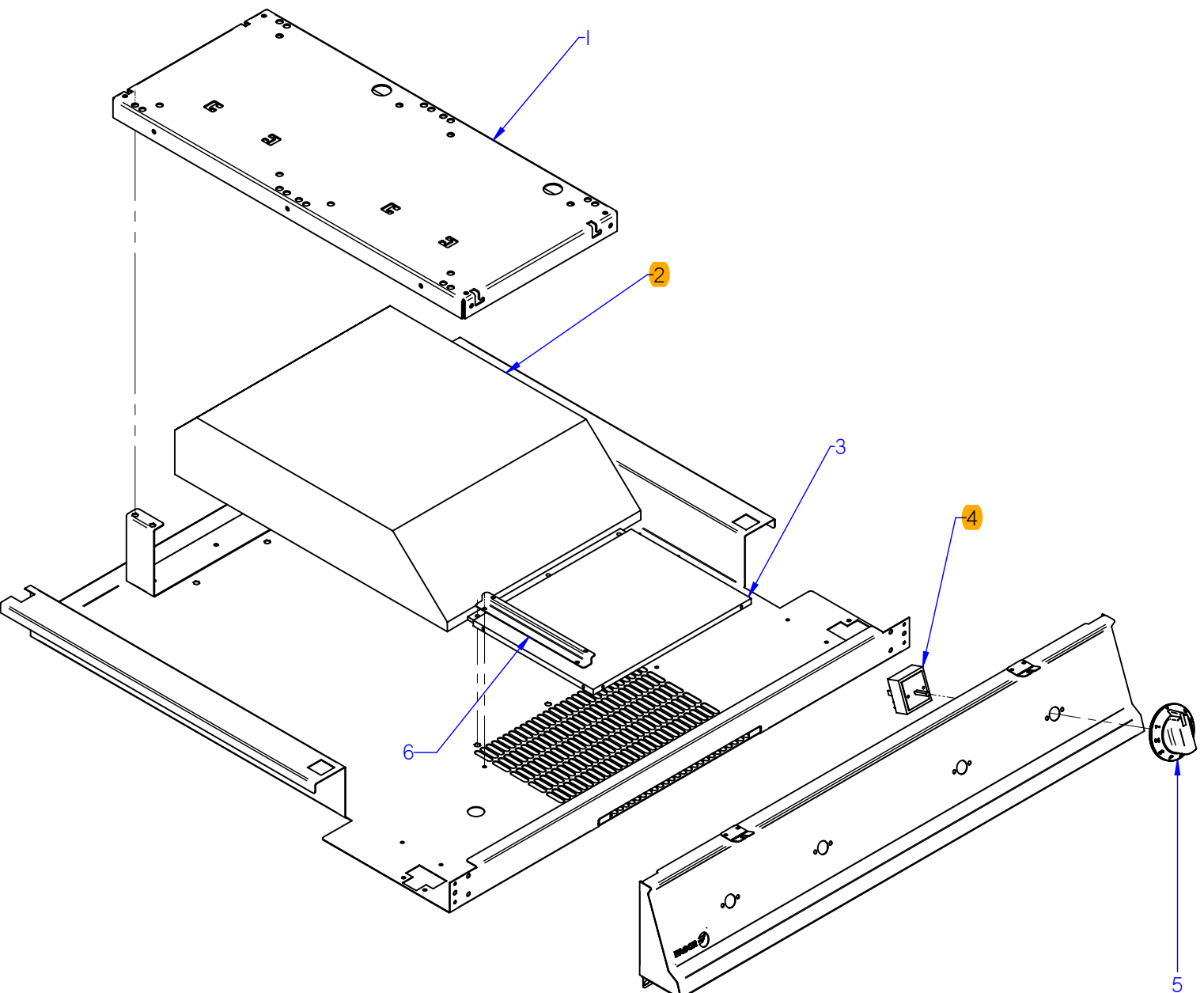

ITEM MARCADO EN COLOR = REPUESTO RECOMENDADO  
COLOURED ITEM = RECOMMENDED SPARE PART

Nº plano / N° plane  
C-2694

Firma  
*Jose Benito*

Fecha / Date  
2011-03

Denominación / Denomination:  
COCINA / RANGES CI9-20 AD / CI9-40 AD  
PARTE FUNCIONAL ELECTRICA / ELECTRICAL FUNCTIONAL PART

Lamina / Sheet  
2

**FAGOR**  
FAGOR INDUSTRIAL



