

**Cocinas vitrocerámicas  
Glass-ceramics ranges  
Fourneaux vitrocéramiques  
Ceranherde tischgeräte  
Cucine vitroceramiche  
Placas vitrocerâmicas**

**GAMA 900**

**Modelos:**

**CV9-20 PLUS  
CV9-40 PLUS**

***Octubre 2011 October***  
***Revisado Junio 2013 June Revised***



---

F A G O R I N D U S T R I A L

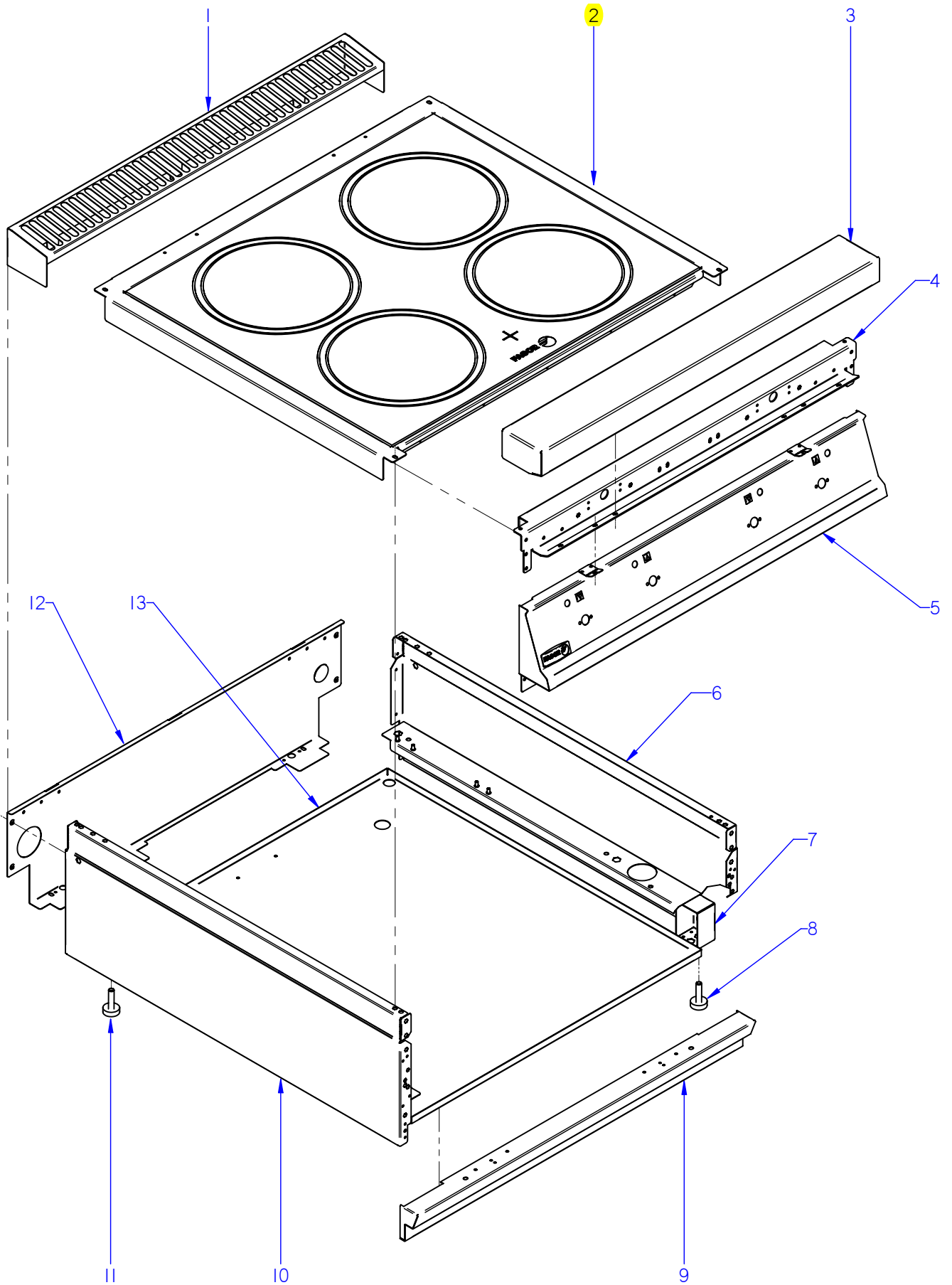

ITEM MARCADO EN COLOR = REPUESTO RECOMENDADO  
 COLOURED ITEM = RECOMMENDED SPARE PART

Nº plano / N° plane	Firma	Fecha / Date	Denominación / Denomination:	MUEBLE / FITTING	Lamina / Sheet	FAGOR
C-2896	<i>[Signature]</i>	2011-10	COCINA / RANGES CV9-20 / CV9-40 PLUS		1	FAGOR INDUSTRIAL

MOD.	COCINAS / RANGES		ZONA / ZONE	MUEBLE / FITTING							PLANO DIAGRAM	C-2896	
ITEM	CODIGO REFERENCE	DENOMINACION	DENOMINATION	CV9-20 PLUS	CV9-40 PLUS						ELIMINADO ELIMINATED	INTRODUCID. INTRODUCED	NOTAS
1	U965406000	EMBELLECEDOR CHIMENEA 1/2M	TRIM CHIMEMEY 1/2M	1	-								
1	U022851000	EMBELLECEDOR CHIMENEA 1M	TRIM CHIMEMEY 1M	-	1								
2	U175408000	ENCIMERA COMPLETA CV9-20	TOP CV9-20 COMPL.	1	-								
2	U175407000	ENCIMERA COMPLETA CV9-40	TOP CV9-40 COMPL.	-	1								
	Q012032000	TORNILLO EXAGONAL M5x15 A304	HEXAGONAL BOLT M5x15	4	6								
3	R045416000	ANTERIOR DE MESA 1/2 M	BENCH FRONT 1/2 M	1	-								
3	S105402000	ANTERIOR MESA 1 M	BENCH FRONT 1 M	-	1								
	Q152004000	TORNIL, APLASTADO M5x13 A304	FLAT HEADED BOLT M5x13 A304	2	2								
	Q302022000	ARANDELA 16x6x1,2 A304	WASHER 16x6x1,2 A304	2	2								
4	U172622000	ESCUADRA INTER. DE MESA 1/2M	INTER BRACKET. TABLE 1/2M	1	-								
4	U172618000	ESCUADRA INTER. DE MESA 1M	INTER BRACKET. TABLE 1 M	-	1								
	Q221342000	REMACHE EXAGONAL M5	HEXAGONAL RIVET M5	2	4								
	Q012032000	TORNILLO EXAGONAL M5x15 A304	HEXAGONAL BOLT M5x15	6	6								
	Q302022000	ARANDELA 16x6x1,2 A304	WASHER 16x6x1,2 A304	4	4								
	Q419005000	REMACHE 4x8 ALMG3 / ALUMINIO	RIVET 4X8 ALMG3 / ALUMINIUM	3	7								
	Q221341000	REMACHE EXAGONAL M4	HEXAGONAL RIVET M4	1	1								
	Q221345000	REMACHE EXAGONAL M10	HEXAGONAL RIVET M10	4	8								
5	U142814000	PORTAMANDOS CE9-20	CONTROL HOLDER CE9-20	1	-								
5	U172807000	PORTAMANDOS CE9-40	CONTROL HOLDER CE9-40	-	1								
	U022836000	ESCUDO FAGOR	FAGOR EMBLEM	1	1								
	Q221023000	CLIP SUJECIÓN RÁPIDA Ø5	RAPID CONNECT CLIP Ø5	2	2								
	Q152004000	TORNIL, APLASTADO M5x13 A304	FLAT HEADED BOLT M5x13 A304	2	2								
6	R062810000	PANEL LATERAL DERECHO	RIGHT SIDE PANEL	1	1								
	Q221343000	REMACHE EXAGONAL M6	HEXAGONAL RIVET M6	5	5								
	Q221342000	REMACHE EXAGONAL M5	HEXAGONAL RIVET M5	2	2								
	Q221342000	REMACHE EXAGONAL M5	HEXAGONAL RIVET M5	3	3								
7	U962627000	ESCUADRA AMARRE PATA AD	LEG FASTENING BRACKET AD	2	2								
	Q162030000	TUERCA EXAGONAL M5	HEXAGONAL NUT M5	4	4								
	Q302022000	ARANDELA 16x6x1,2 A304	WASHER 16x6x1,2 A304	4	4								
	X010503000	CIERRE MUELLE	LOCK SPRING	2	2								
8	Z200107000	PATA REGULABLE	ADJUSTABLE LEG	2	2								



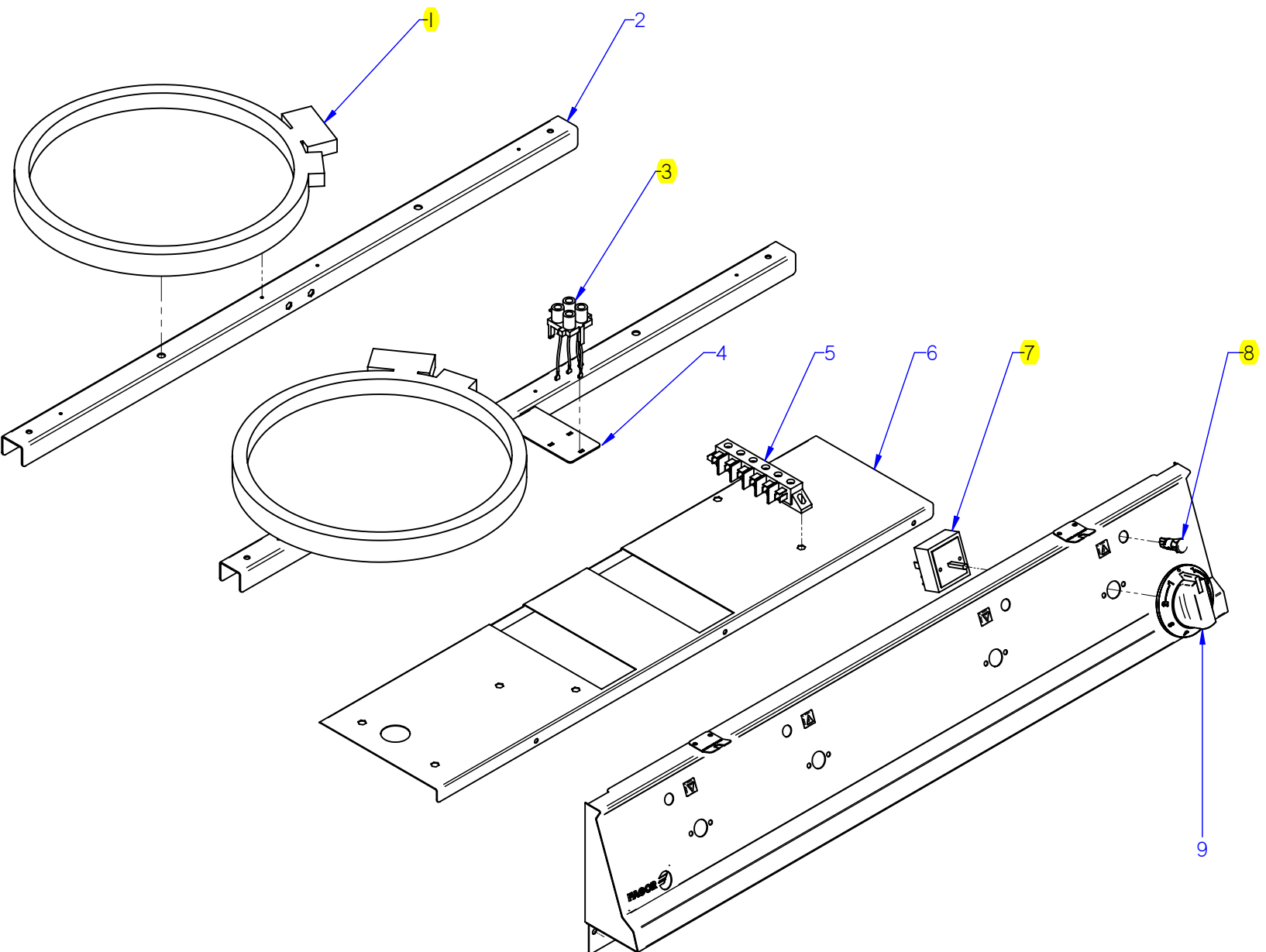

ITEM MARCADO EN COLOR = REPUESTO RECOMENDADO  
COLOURED ITEM = RECOMMENDED SPARE PART

Nº plano / N° Plane  
**C-2897**

Firma  
*Jose Guejra*

Fecha / Date  
**2011-10**

Denominación / Denomination:  
PARTE FUNCIONAL ELECTRICA / ELECTRICAL FUNCTIONAL PART  
**COCINA / RANGES CV9-20 / CV9-40 PLUS**

Lamina / Sheet

**2**

**FAGOR**  
FAGOR INDUSTRIAL











# CV 9 - 40

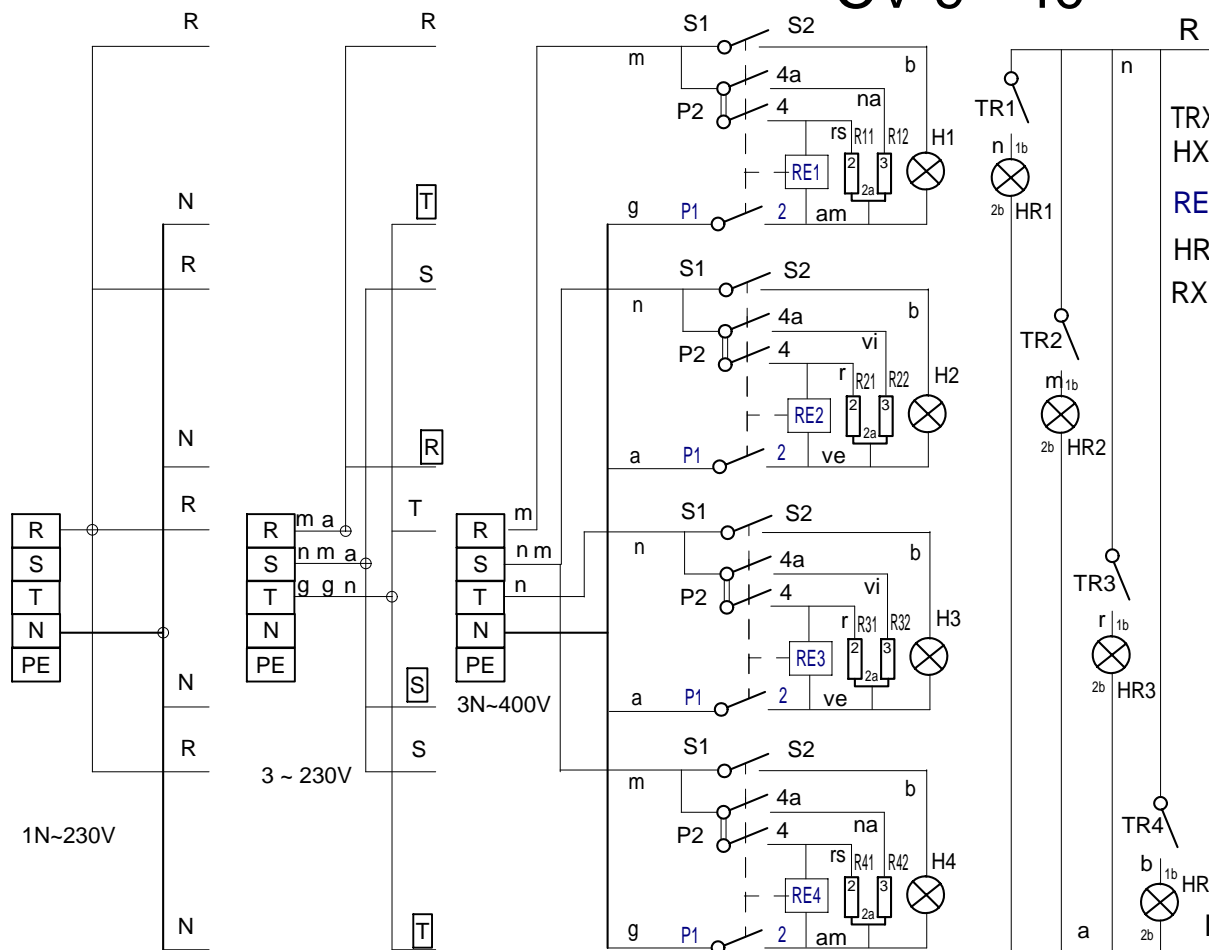

TRX : Termostato Calor residual / Residual heating thermostat  
 HX: Lámpara funcionamiento / Operating Lamp  
 REX: Regulador de energia / Energy Regulatory  
 HRX: Luz Calor residual / Residual heat lamp  
 RX: Resistencia de Calentamiento / Resistance heating

°	% ±2%	P1 - 2		P2-4	P2-4a	S1-S2
		TON	TON+TOF			
0	0	0	∞			
30°	6%	4"	38"	X		X
70°	15%	7"	29"	X		X
110°	30%	13"	32"	X		X
150°	75%	45"	60"	X		X
154°	100%	∞	∞	X		X
206°	100%	∞	∞	X	X	X
210°	75%	45"	60"	X	X	X
250°	30%	13"	32"	X	X	X
290°	15%	7"	29"	X	X	X
330°	6%	4"	38"	X	X	X

a = azul-blue  
 am = amarillo - yellow  
 vi = violeta - violet  
 g = gris-grey  
 m = marron-brown  
 n = negro-black  
 r = rojo-red  
 rs =rosa - pink  
 am/ve = amarillo/verde  
 - yellow/green

U173010000

Esquema Teorico CV 9- 40				U173010000			
Zk./Nº	Pieza	Cant.	Materiala/Material	Klas. zk/Nº Clas.	Gainazal akabera/Tratamiento		
Zk./Nº	Aldaketa/Modificaciones		Nork proposatua/Propuesta de	Data/Fecha	Perdoi orokorrak Tolerancias generales		
-	-	-	-	-	< 5 ± 0.2	50 ÷ 100 ± 0.3	
-	-	-	-	-	5 ÷ 25 ± 0.4	>100 ± 1	
-	-	-	-	-	25 ÷ 50 ± 0.6	α ± 1	
-	-	-	-	-	-	-	
Sinadura/Firma		Data/Fecha		Gainazal perdoia Mecanizado superficial			
Marraztua/Dibujado		M.Mailla		2010-03-31		FAGOR 	
Proiektatua/Proyectado		M.Mailla		2010-03-31			
Egiaztatua/Comprobado		I.Alberdi		2010-03-31			
Eskala/Escala		Fagor Industrial, Koop. Elk, Mugatua				Plano Zk./Plano Nº	
-		COCINA VITROCERAMICA				HC-82372	
-		Plano hau ezin daiteke erabili, ez berrizatu, gure baimenik gabe.				- Zk. ord. du	
-		-				- Zk. gaitik ord.	

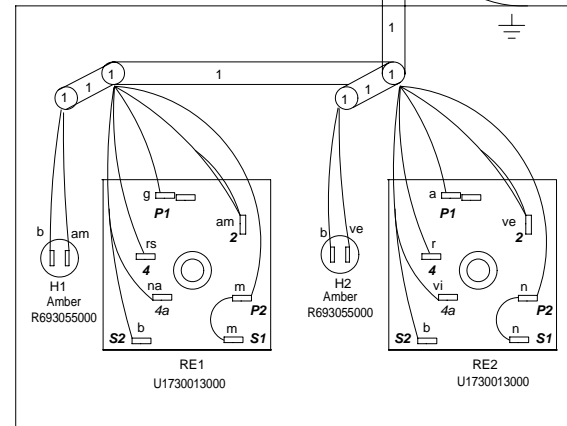
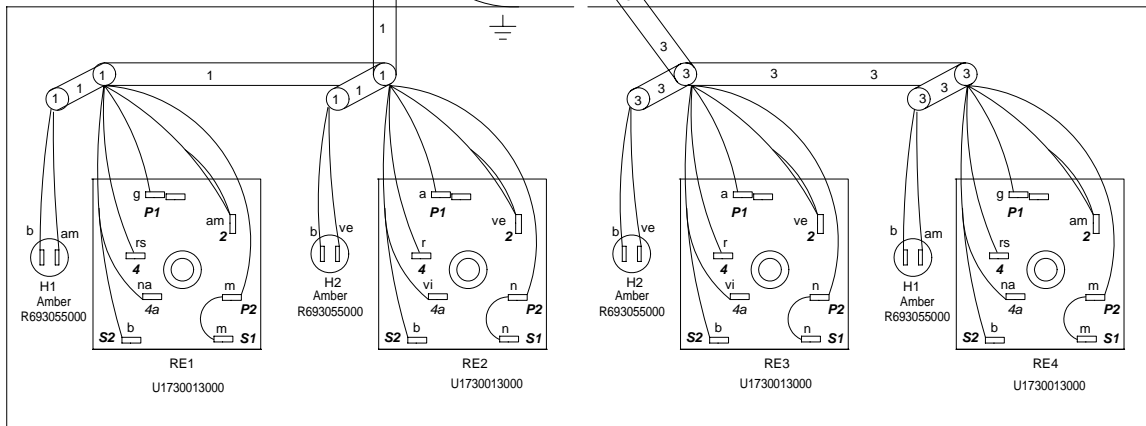
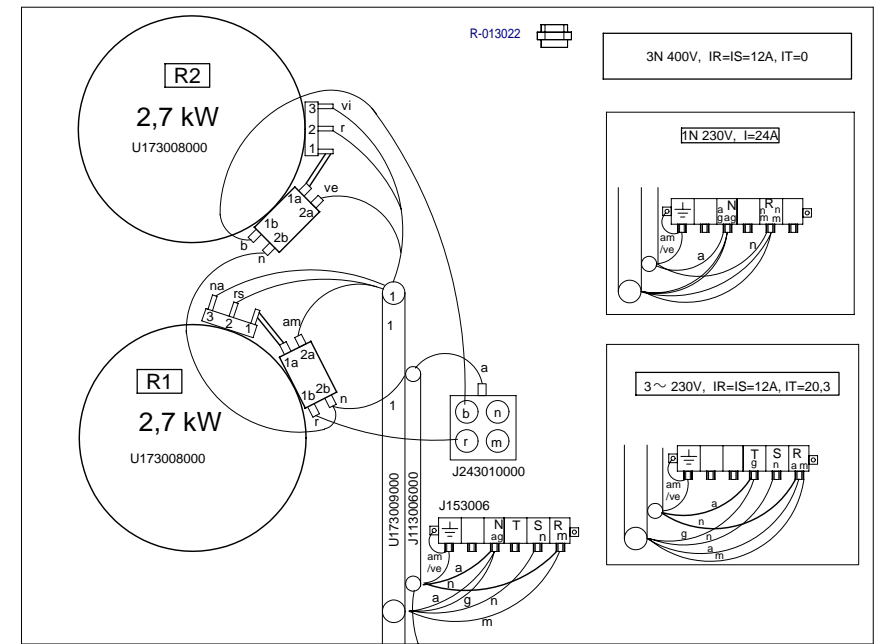
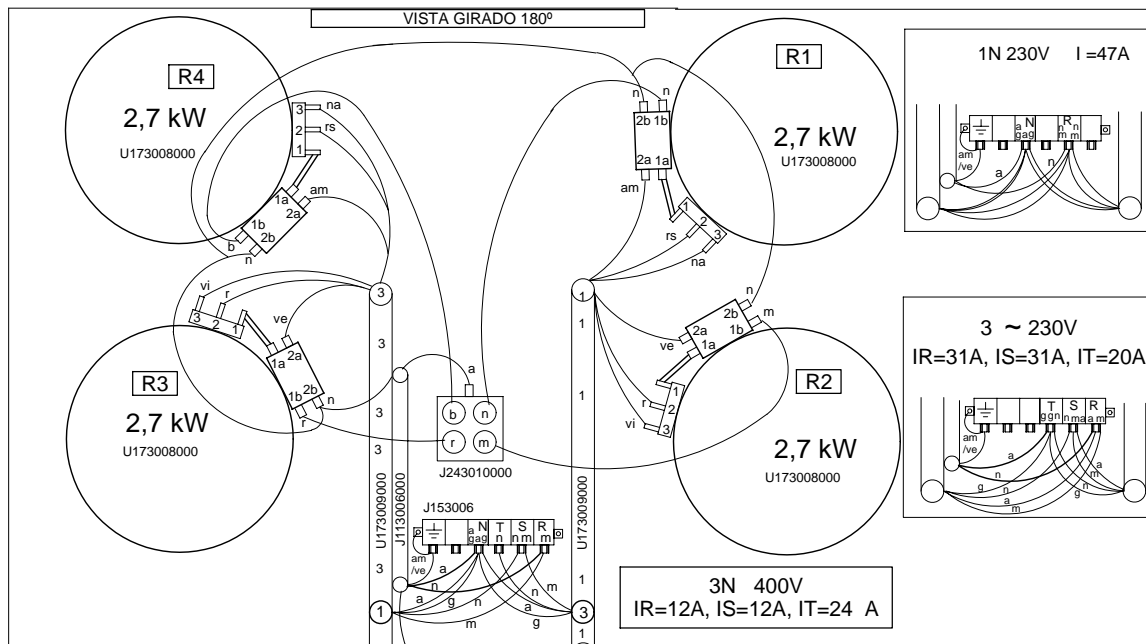

# CV 9 - 40

# CV 9 - 20

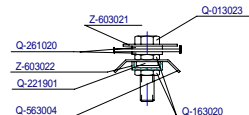

Plano Montaje CV 9-20, CV 9-40				U173012000	
Zk./Nº	Pieza	Cant.	Materia/Material	Klas. zk/Nº Clas.	Gainazal akabera/Tratamiento
Zk./Nº	Aldaketa/Modificaciones		Nork proposatua/Propuesta de	Data/Fecha	Perdoi orokorrak Tolerancias generales
-	-	-	-	-	< 5 ± 0,2   50 ± 100 ± 0,8
-	-	-	-	-	5 ± 25 ± 0,3   >100 ± 1
-	-	-	-	-	25 ± 50 ± 0,6   α ± 1
Marratzua/Dibujado			M.Mailló	2010-03-31	Gainazal perloia Mecanizado superficial
Proiektatua/Proyectado			M.Mailló	2010-03-31	
Egiaztatua/Comprobado			J.Alberdi	2010-03-31	
Eskala/Escala					
<b>COCINA VITROCERAMICA</b>				Plano Zk./Plano Nº HC-82373	
Plano hau ezin daterke erabili, ez berrizatu, gure baitan gabe.					- Zk. ord. du.
					- Zk.gaitik ord.