DESPIECES DEL SERVICIO TECNICO

SERIE 900

Cocinas a Gas - Fourneaux à gaz
Gas Ranges - Gasherde - Cuisine a gas

CG9-20 CG9-40
CG9-60 CG9-41
CG9-61 CG9-82

NOVIEMBRE 2000



Fagor Industrial

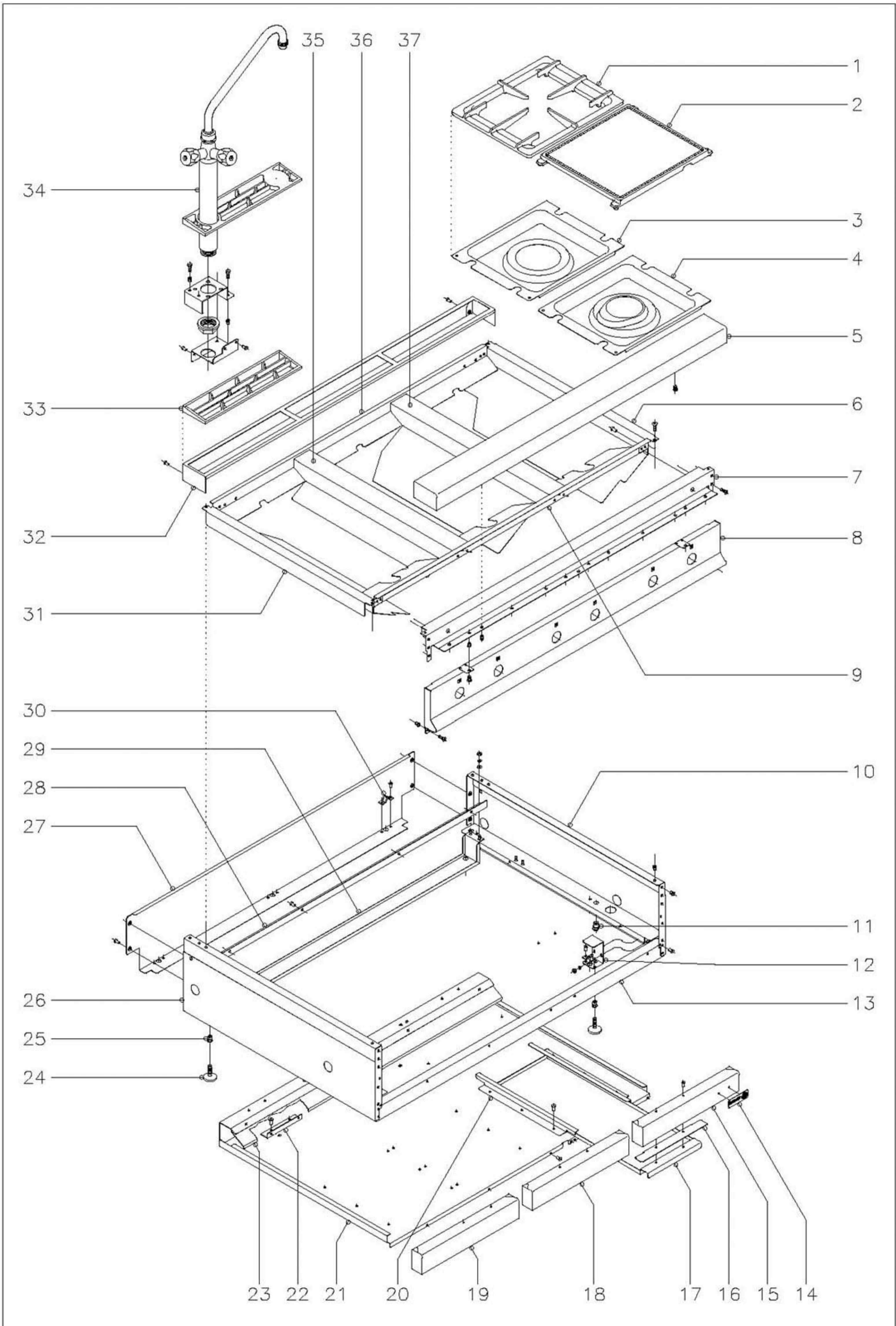

N plano C-881	Firma <i>[Signature]</i>	Fecha 11-00	Aparato COCINAS CG9-20, 40, 60	Lamina 1	Fagor Industrial S.Coop. 0<ate	FAGOR
------------------	-----------------------------	----------------	-----------------------------------	-------------	-----------------------------------	--------------

MOD.

COCINAS

ZONA

MUEBLE

PLANO

C-881

ITEM	CODIGO	DENOMINACION	TEXTO	CG9-20	CG9-40	CG9-60							NOTAS
1	U565403	Parrilla		2	4	6							
2	U565406	Placa		-	-	-							(Se suministra bajo pedido)
3	U505409	Vertedero 6000		1	2	3							
4	U505408	Vertedero 4000		1	2	3							
5	X165400	Anterior de mesa 1/2 M.		1	-	-							
5	R165431	Anterior de mesa 1 M.		-	1	-							
5	U585451	Anterior de mesa 1 1/2 M.		-	-	1							
	Q152004	Tornillo aplastado M-5x13		4	4	4							
	Q221342	Remache exagonal M-5		4	4	4							
6	U565450	Lateral derecho de mesa		1	1	1							
	Q152004	Tornillo aplastado M-5x13		2	2	2							
	Q221342	Remache exagonal M-5		2	2	2							
	Q419005	Remache tubular Ø4x8		4	4	4							
7	X162667	Escuadra amarre anterior mesa		1	-	-							
7	R162613	Escuadra amarre anterior mesa		-	1	-							
7	U582655	Escuadra amarre anterior mesa		-	-	1							
	Q152004	Tornillo aplastado M-5x13		6	6	6							
	Q221342	Remache exagonal M-5		6	6	6							
8	U542850	Panel portamandos		1	-	-							
8	U562855	Panel portamandos		-	1	-							
8	U582851	Panel portamandos		-	-	1							
	Q152004	Tornillo aplastado M-5x13		4	4	4							
	Q221342	Remache exagonal M-5		4	4	4							
9	U545451	Anterior interior de mesa		1	-	-							
9	U565453	Anterior interior de mesa		-	1	-							
9	U585453	Anterior interior de mesa		-	-	1							
10	R162810	Panel lateral derecho		1	1	1							
11	Q221345	Remache exagonal M-10		2	2	2							

MOD.

COCINAS

ZONA

MUEBLE

PLANO

C-881

ITEM	CODIGO	DENOMINACION	TEXTO	CG9-20	CG9-40	CG9-60							NOTAS
12	H012805	Escuadra amarre pata		2	2	2							
	Q302022	Arandela plana Ø16xØ6x1,2		4	4	4							
	Q162030	Tuerca exagonal M-5		4	4	4							
13	U652651	Liston amarre zocalo		1	-	-							
13	H022604	Liston amarre zocalo		-	1	-							
13	U572653	Liston amarre zocalo		-	-	1							
	Q419005	Remache tubular Ø4x8		4	4	4							
14	U262806	Escudo FAGOR		1	1	1							
	Q221023	Clips sujecion escudo		2	2	2							
15	H012804	Asa bandeja derecha		-	1	1							
16	H012807	Refuerzo asa		1	2	3							
17	U722604	Bandeja recoge grasas		1	2	3							
18	H012809	Asa bandeja		1	-	-							
18	U572851	Asa bandeja central		-	-	1							
19	H012806	Asa bandeja izquierda		-	1	1							
	Q419005	Remache tubular Ø4x8		2	4	6							
20	U562640	Guia de bandejas		2	4	6							
	Q419005	Remache tubular Ø4x8		6	12	18							
21	U542650	Base de bandejas		1	-	-							
21	U562651	Base de bandejas		-	1	-							
21	U582653	Base de bandejas		-	-	1							
	Q152004	Tornillo aplastado M-5x13		2	2	2							
	Q419005	Remache tubular Ø4x8		2	3	3							
22	U325611	Escuadra tope bandejas		1	2	3							
	Q419005	Remache tubular Ø4x8		2	4	6							
23	U542651	Suplemento base de bandejas		1	-	-							
23	U562652	Suplemento base de bandejas		-	1	-							
23	U582654	Suplemento base de bandejas		-	-	1							
	Q419005	Remache tubular Ø4x8		2	3	4							

MOD.

COCINAS

ZONA

MUEBLE

PLANO

C-881

ITEM	CODIGO	DENOMINACION	TEXTO	CG9-20	CG9-40	CG9-60							NOTAS
24	Z200105	Pata regulable		4	4	4							
25	Q221345	Remache exagonal M-10		4	4	4							
26	R162812	Panel lateral izquierdo		1	1	1							
27	R152811	Panel posterior		1	-	-							
27	R162813	Panel posterior		-	1	-							
27	U572850	Panel posterior		-	-	1							
	Q419005	Remache tubular Ø4x8		4	4	8							
28	H012603	Escuadra posterior base bandejas		1	-	-							
28	H022603	Escuadra posterior base bandejas		-	1	-							
28	U572651	Escuadra posterior base bandejas		-	-	1							
	Q419005	Remache tubular Ø4x8		2	3	4							
29	H012606	Refuerzo posterior patas		1	-	-							
29	H022606	Refuerzo posterior patas		-	1	-							
29	U572652	Refuerzo posterior patas		-	-	1							
	Q302022	Arandela plana Ø16xØ6x1,2		4	4	4							
	Q162030	Tuerca exagonal M-5		4	4	4							
30	X010503	Muelle enganche piton		4	4	5							
	Q419007	Remache tubular Ø3,2x6		8	8	10							
31	U565451	Lateral izquierdo de mesa		1	1	1							
	Q152004	Tornillo aplastado M-5x13		2	2	2							
	Q221342	Remache exagonal M-5		2	2	2							
	Q419005	Remache tubular Ø4x8		4	4	4							
32	R205429	Soporte embellecedor		1	-	-							
32	R205428	Soporte embellecedor		-	1	-							
32	R205430	Soporte embellecedor		-	-	1							
	Q419005	Remache tubular Ø4x8		2	2	2							
33	R205425	Embellecedor chimenea		1	2	3							

MOD.

COCINAS

ZONA

MUEBLE

PLANO

C-881

ITEM	CODIGO	DENOMINACION	TEXTO	CG9-20	CG9-40	CG9-60							NOTAS
34	1100002703 (KIT GRIFO DE AGUA IZDO.)			-	-	-							(Se suministra bajo pedido)
	U706500	Grifo de agua con tuerca		1	1	1							
	R205431	Embellecedor chime. kit izdo.		1	1	1							
	E542606	Soporte grifo de agua izdo.		1	1	1							
	Q012043	Tornillo exagonal M-6x20		4	4	4							
	Q221343	Remache exagonal M-6		4	4	4							
	E542601	Union refuerzo grifo agua izdo.		1	1	1							
	Q419005	Remache tubular Ø4x8		5	5	5							
34	1100002704 (KIT GRIFO DE AGUA DECHO.)			-	-	-							(Se suministra bajo pedido)
	U706500	Grifo de agua con tuerca		1	1	1							
	R205432	Embellecedor chime. Kit decho.		1	1	1							
	E542605	Soporte grifo de agua decho.		1	1	1							
	Q012043	Tornillo exagonal M-6x20		4	4	4							
	Q221343	Remache exagonal M-6		4	4	4							
	E542603	Union refuerzo grifo agua decho.		1	1	1							
	Q419005	Remache tubular Ø4x8		5	5	5							
35	U565454	Central de mesa		-	1	1							
36	U545450	Posterior interior de mesa		1	-	-							
36	U565452	Posterior interior de mesa		-	1	-							
36	U585452	Posterior interior de mesa		-	-	1							
37	U585454	Central de mesa derecho		-	-	1							
	Q419005	Remache tubular Ø4x8		-	6	12							

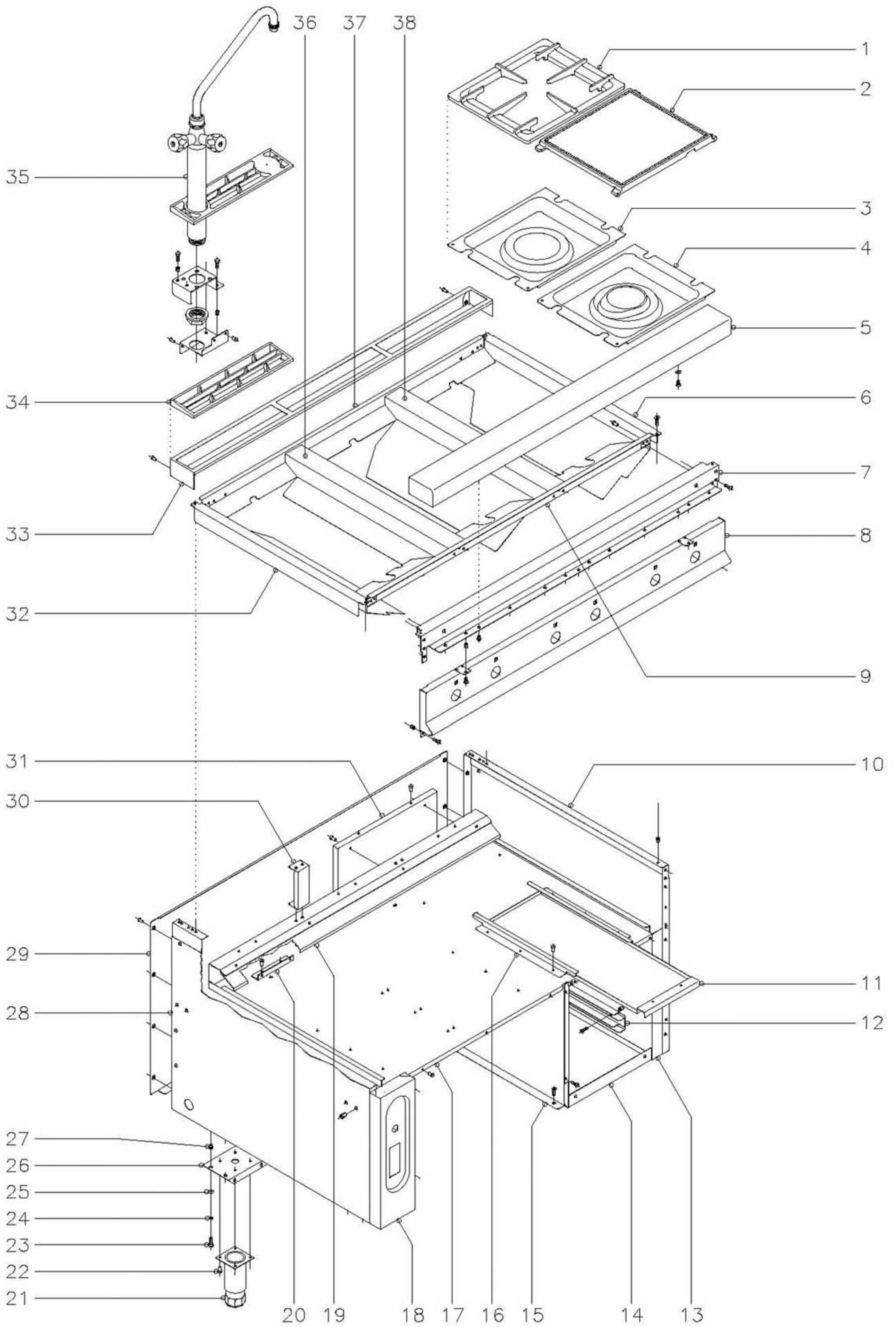

MOD.		COCINAS		ZONA		MUEBLE					PLANO		C-882	
ITEM	CODIGO	DENOMINACION	TEXTO	CG9-41	CG9-61	CG9-82							NOTAS	
1	U565403	Parrilla		4	6	8								
2	U565406	Placa		-	-	-							(Se suministra bajo pedido)	
3	U505409	Vertedero 6000		2	3	4								
4	U505408	Vertedero 4000		2	3	4								
5	R165431	Anterior de mesa 1M.		1	-	-								
5	U585451	Anterior de mesa 1 1/2 M.		-	1	-								
5	U595460	Anterior de mesa 2 M.		-	-	1								
	Q152004	Tornillo aplastado M-5x13		4	4	4								
	Q221342	Remache exagonal M-5		4	4	4								
6	U565450	Lateral derecho de mesa		1	1	1								
	Q152004	Tornillo aplastado M-5x13		2	2	2								
	Q221342	Remache exagonal M-5		2	2	2								
	Q419005	Remache tubular Ø4x8		4	4	4								
7	R162613	Escuadra amarre anterior mesa		1	-	2								
7	U582655	Escuadra amarre anterior mesa		-	1	-								
	Q152004	Tornillo aplastado M-5x13		6	6	12								
	Q221342	Remache exagonal M-5		6	6	12								
8	U562855	Panel portamandos		1	-	-								
8	U582851	Panel portamandos		-	1	-								
8	U592850	Panel portamandos		-	-	1								
	Q152004	Tornillo aplastado M-5x13		4	4	4								
	Q221342	Remache exagonal M-5		4	4	4								
9	U565453	Anterior interior de mesa		1	-	2								
9	U585453	Anterior interior de mesa		-	1	-								
10	U562852	Panel lateral derecho		1	-	2								
10	X162811	Panel lateral derecho		-	1	-								
11	U722604	Bandeja recoge grasas		2	3	4								
12	U582665	Guia para bandejas 1/1		-	4	-								
	Q152004	Tornillo aplastado M-5x13		-	12	-								

MOD.		COCINAS		ZONA		MUEBLE					PLANO		C-882	
ITEM	CODIGO	DENOMINACION	TEXTO	CG9-41	CG9-61	CG9-82								NOTAS
	Q221342	Remache exagonal M-5		-	12	-								
13	U582658	Panel lateral interior derecho		-	1	-								
	Q152004	Tornillo aplastado M-5x13		-	2	-								
	Q221342	Remache exagonal M-5		-	2	-								
14	U582659	Base interior lateral		-	1	-								
	Q419005	Remache tubular Ø4x8		-	4	-								
15	U582656	Panel lateral interior izquierdo		-	1	-								
	Q152004	Tornillo aplastado M-5x13		-	2	-								
	Q221342	Remache exagonal M-5		-	2	-								
16	U562640	Guia bandejas		4	6	8								
	Q419005	Remache tubular Ø4x8		12	18	24								
17	U562651	Base de bandejas		1	-	2								
17	U582653	Base de bandejas		-	1	-								
	Q419005	Remache tubular Ø4x8		3	3	6								
18	U562854	Portamandos lateral		1	1	2								
	Q152004	Tornillo aplastado M-5x13		2	2	4								
	Q221304	Remache redondo M-5		2	2	4								
19	U562652	Suplemento base bandejas		1	-	2								
19	U582654	Suplemento base bandejas		-	1	-								
	Q419005	Remache tubular Ø4x8		3	4	6								
20	U325611	Escuadra tope bandejas		2	3	4								
	Q419005	Remache tubular Ø4x8		4	6	8								
21	X260150	Pata regulable		4	4	4								
22	Q411304	Remache avibulb Ø4,8		16	16	16								
23	Q012043	Tornillo exagonal M-6x20		8	8	16								
24	Q262040	Arandela grower A-6		8	8	16								
25	Q302022	Arandela plana Ø16xØ6x1,2		8	8	16								
26	X172601	Liston soporte patas		2	-	-								
26	U582652	Liston soporte patas		-	2	-								

MOD.

COCINAS

ZONA

MUEBLE

PLANO

C-882

ITEM	CODIGO	DENOMINACION	TEXTO	CG9-41	CG9-61	CG9-82							NOTAS
26	U592650	Liston soporte patas		-	-	2							
27	Q221343	Remache exagonal M-6		8	8	16							
28	X162810	Panel lateral izquierdo		1	1	2							
29	U562853	Panel posterior		1	-	-							
29	U582852	Panel posterior		-	1	-							
29	U592852	Panel posterior		-	-	1							
	Q419005	Remache tubular Ø4x8		8	8	16							
30	U572650	Poste posterior		-	2	-							
	Q152004	Tornillo aplastado M-5x13		-	4	-							
	Q221342	Remache exagonal M-5		-	4	-							
31	U582657	Panel interior posterior		-	1	-							
	Q419005	Remache tubular Ø4x8		-	5	-							
32	U565451	Lateral izquierdo de mesa		1	1	1							
	Q152004	Tornillo aplastado M-5x13		2	2	2							
	Q221342	Remache exagonal M-5		2	2	2							
	Q419005	Remache tubular Ø4x8		4	4	4							
33	R205428	Soporte embellecedor		1	-	2							
33	R205430	Soporte embellecedor		-	1	-							
	Q419005	Remache tubular Ø4x8		2	2	4							
34	R205425	Embellecedor chimenea		2	3	4							
35	1100002703 (KIT GRIFO DE AGUA IZDO.)			-	-	-							(Se suministra bajo pedido)
	U706500	Grifo de agua con tuerca		1	1	1							
	R205431	Embellecedor chime. Kit izdo.		1	1	1							
	E542606	Soporte grifo de agua izdo.		1	1	1							
	Q012043	Tornillo exagonal M-6x20		4	4	4							
	Q221343	Remache exagonal M-6		4	4	4							
	E542601	Union refuerzo grifo agua izdo.		1	1	1							
	Q419005	Remache tubular Ø4x8		5	5	5							

MOD.

COCINAS

ZONA

MUEBLE

PLANO

C-882

ITEM	CODIGO	DENOMINACION	TEXTO	CG9-41	CG9-61	CG9-82									NOTAS
35	1100002704	(KIT GRIFO DE AGUA DECHO.)		-	-	-									(Se suministra bajo pedido)
	U706500	Grifo de agua con tuerca		1	1	1									
	R205432	Embellecedor chime. Kit decho.		1	1	1									
	E542605	Soporte grifo de agua decho.		1	1	1									
	Q012043	Tornillo exagonal M-6x20		4	4	4									
	Q221343	Remache exagonal M-6		4	4	4									
	E542603	Union refuerzo grifo agua decho.		1	1	1									
	Q419005	Remache tubular Ø4x8		5	5	5									
36	U565454	Central de mesa		1	1	2									
37	U565452	Posterior interior de mesa		1	-	2									
37	U585452	Posterior interior de mesa		-	1	-									
38	U585454	Central de mesa derecho		-	1	-									
38	U595461	Union central de cocina		-	-	1									
	Q419005	Remache tubular Ø4x8		6	12	20									
	Q152004	Tornillo aplastado M-5x13		-	-	4									
	Q221342	Remache exagonal M-5		-	-	4									

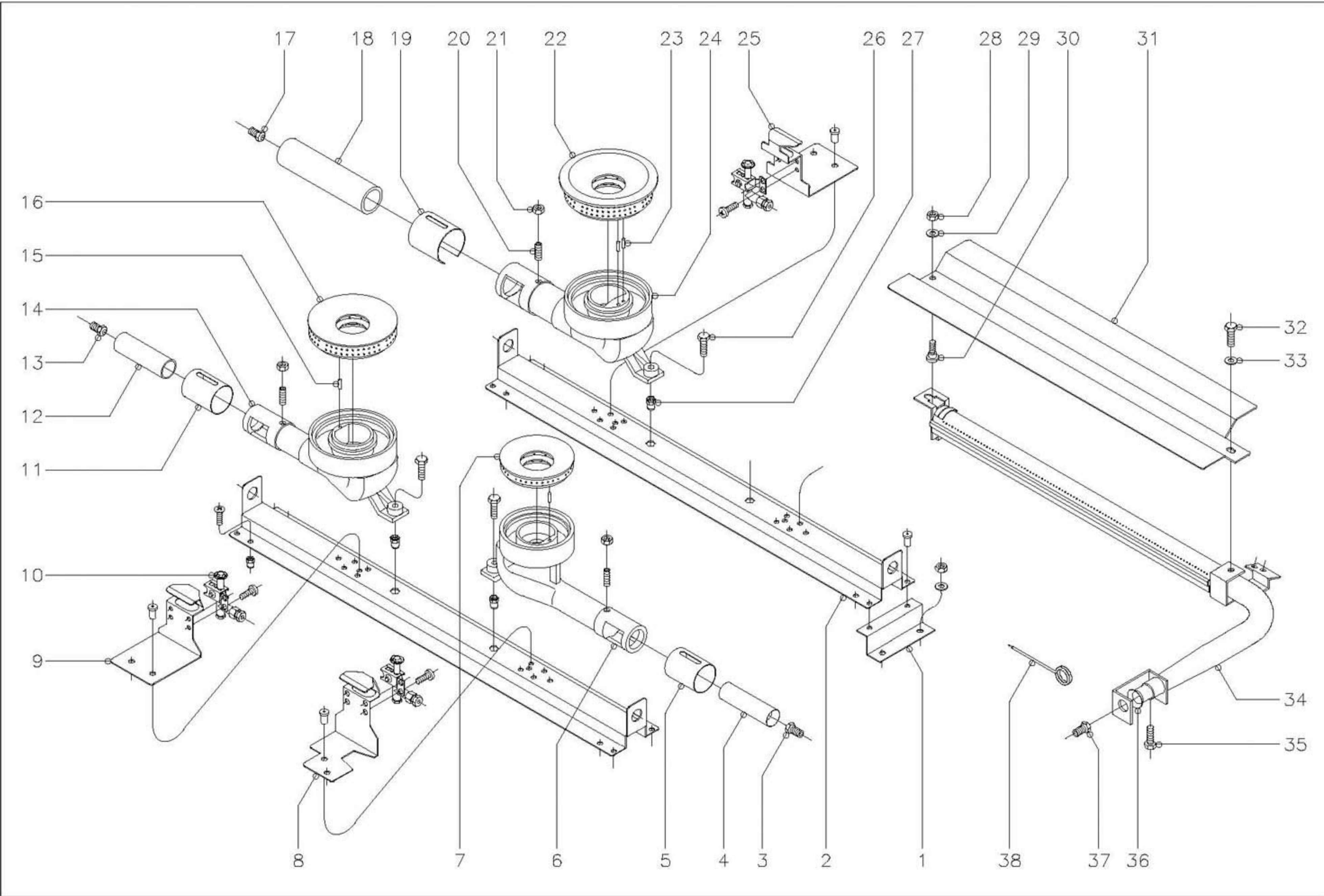

N plano	Firma	Fecha	Aparato	Lamina	Fagor Industrial S.Coop.	FAGOR
C-883	<i>[Signature]</i>	11-00	COCl. CG9-20,40,60,41,61,82	3	Q-cate	

MOD.

COCINAS

QUEMADORES

PLANO

C-883

ITEM	CODIGO	DENOMINACION	TEXTO	CG9-20	CG9-40	CG9-60	CG9-41	CG9-61	CG9-82				NOTAS
1	U562655	Escuadra soporte liston		1	2	3	2	3	4				
	Q302022	Arandela plana Ø16xØ6x1,2		2	4	6	4	6	8				
	Q162040	Tuerca exagonal M-6		2	4	6	4	6	8				
2	U562654	Liston amarre quemadores		1	2	3	2	3	4				
3	U122407	Tobera Ø1,05 (B.P.) 4000		1	2	3	2	3	4				
3	9105100	Tobera Ø1,50 (G.N.) 4000		1	2	3	2	3	4				
3	R302401	Tobera Ø2,90 (G.V.) 4000		1	2	3	2	3	4				
4	U125720	Venturi quemador 4000		1	2	3	2	3	4				
5	U265702	Regulador de aire 4000		1	2	3	2	3	4				
6	U445730	Cuerpo quemador 4000		1	2	3	2	3	4				
7	U445731	Quemador 4000		1	2	3	2	3	4				
8	U505440	Soporte piloto 4000		1	2	3	2	3	4				
	Q419005	Remache tubular Ø4x8		2	4	6	4	6	8				
9	U445441	Soporte piloto 8000 y 10500		1	1	2	1	2	2				
	Q419005	Remache tubular Ø4x8		2	4	6	4	6	8				
10	U442134	Conjunto piloto mesa		2	4	6	4	6	8				
	U442138	Inyector piloto Ø0,25 (B.P.y G.V.)		2	4	6	4	6	8				Regular para G.V.
	U442137	Inyector piloto Ø0,40 (Gas Natural)		2	4	6	4	6	8				
11	U265702	Regulador de aire 8000		1	1	2	1	2	2				
12	U565700	Venturi quemador 8000		1	1	2	1	2	2				
13	0631000	Tobera Ø1,40 (B.P.) 8000		1	1	2	1	2	2				
13	R614500	Tobera Ø2,00 (G.N.) 8000		1	1	2	1	2	2				
13	U262401	Tobera Ø4,10 (G.V.) 8000		1	1	2	1	2	2				
14	U565701	Cuerpo quemador 8000		1	1	2	1	2	2				
15	Q371026	Manguito Ø4x14 (4000 y 8000)		2	3	5	3	5	6				
16	U135702	Quemador 8000		1	1	2	1	2	2				
17	U112401	Tobera Ø1,55 (B.P.) 10500		-	1	1	1	1	2				
17	R275050	Tobera Ø2,35 (G.N.) 10500		-	1	1	1	1	2				
17	U192402	Tobera Ø4,90 (G.V.) 10500		-	1	1	1	1	2				

MOD.

COCINAS

QUEMADORES

PLANO

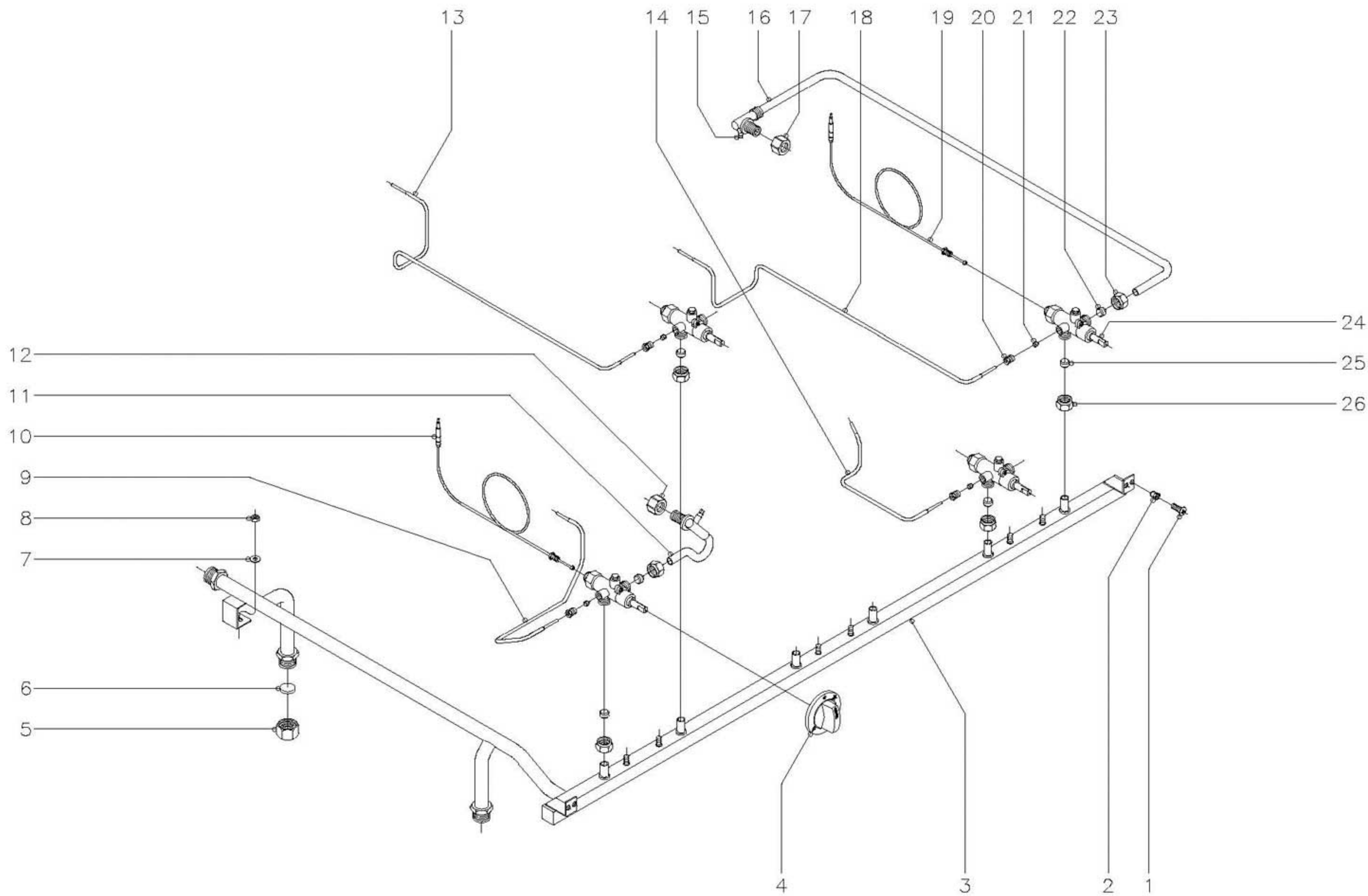

C-883

ITEM	CODIGO	DENOMINACION	TEXTO	CG9-20	CG9-40	CG9-60	CG9-41	CG9-61	CG9-82				NOTAS
18	U235702	Venturi quemador 10500		-	1	1	1	1	2				
19	U235704	Regulador de aire 10500		-	1	1	1	1	2				
20	Q131542	Varilla roscada M-6x15		2	4	6	4	6	8				
21	Q162040	Tuerca exagonal M-6		2	4	6	4	6	8				
22	U235701	Quemador 10500		-	1	1	1	1	2				
23	Q371028	Manguito Ø3x14		-	2	2	2	2	4				
24	U235700	Cuerpo quemador 10500		-	1	1	1	1	2				
25	U445441	Soporte piloto 8000 y10500		-	1	1	1	1	2				
	Q419005	Remache tubular Ø4x8		-	2	2	2	2	4				
26	Q012044	Tornillo exagonal M-6x25		2	4	6	4	6	8				
27	Q221343	Remache exagonal M-6		2	4	6	4	6	8				
28	Q162040	Tuerca exagonal M-6		-	-	-	1	1	2				
29	Q302022	Arandela plana Ø16xØ6x1,2		-	-	-	1	1	2				
30	R252624	Piton soporte		-	-	-	1	1	2				
31	U745705	Difusor quemador horno		-	-	-	1	1	2				
32	Q012041	Tornillo exagonal M-6x10		-	-	-	1	1	2				
33	Q302022	Arandela plana Ø16xØ6x1,2		-	-	-	1	1	2				
34	U745700	Quemador horno		-	-	-	1	1	2				
35	Q012031	Tornillo exagonal M-5x10		-	-	-	1	1	2				
36	U325707	Regulador de aire horno		-	-	-	1	1	2				
37	U052401	Tobera Ø1,45 (B.P.) Horno		-	-	-	1	1	2				
37	1011600	Tobera Ø2,25 (G.N.) Horno		-	-	-	1	1	2				
37	9424600	Tobera Ø4,23 (G.V.) Horno		-	-	-	1	1	2				
38	623500	Aguja limpieza quemadores		1	1	1	1	1	1				

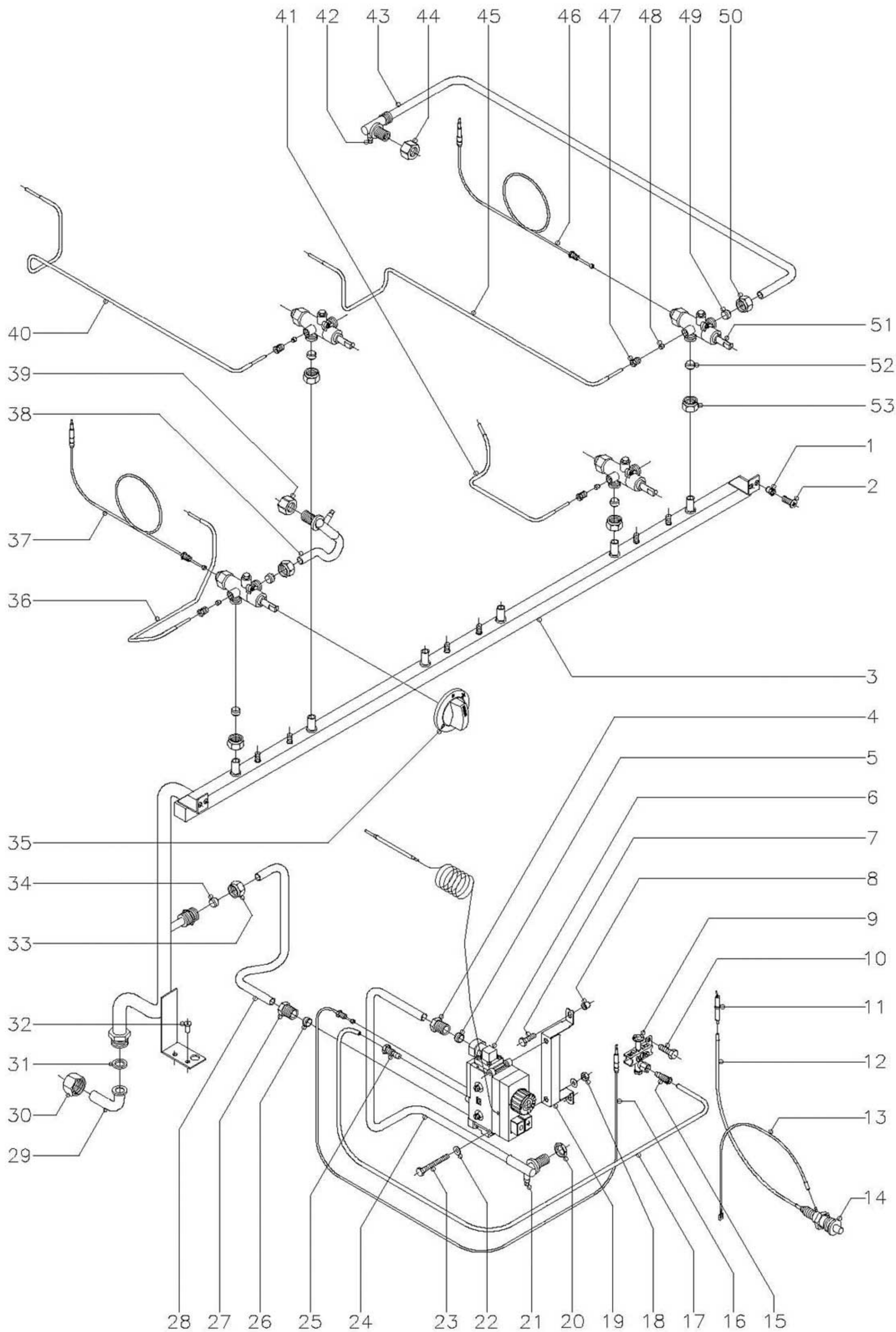

ITEM	CODIGO	DENOMINACION	TEXTO	CG9-20	CG9-40	CG9-60							NOTAS
1	Q152004	Tornillo aplastado M-5x13		2	2	2							
2	Q221342	Remache exagonal M-5		2	2	2							
3	U545002	Tubo distribuidor general		1	-	-							
3	U635002	Tubo distribuidor general		-	1	-							
3	U575002	Tubo distribuidor general		-	-	1							
4	U542101	Boton de mando Ø10		2	4	6							
5	U635008	Tuerca ciega 3/4"		2	2	2							
6	Q306051	Arandela tapon Ø23,5x4		2	2	2							
7	Q302022	Arandela plana Ø16xØ6x1,2		1	1	1							
8	Q162030	Tuerca exagonal M-5		1	1	1							
9	U565034	Tubo piloto anterior izquierdo		1	1	1							
10	U222130	Termopar anterior L=600		1	2	3							
11	U565027	Tubo a quemador anterior		1	2	3							
12	U565011	Tuerca guia quemad. 4000 y 8000		2	3	5							
13	U565032	Tubo piloto posterior izquierdo		1	1	1							
14	U565033	Tubo piloto anterior derecho		-	1	2							
15	Q153002	Tornillo toma presion		2	4	6							
16	U565029	Tubo a quemador posterior		1	2	3							
17	U235703	Tuerca guia quemador 10500		-	1	1							
18	U565031	Tubo piloto posterior derecho		-	1	2							
19	U262130	Termopar posterior L=1000		1	2	3							
20	U322109	Racord 1/8" (Para tubo Ø4)		2	4	6							
21	U265026	Bicono Ø4		2	4	6							
22	U055043	Bicono Ø12		2	4	6							
23	Q221336	Tuerca M-18x1,5 (Para tubo Ø12)		2	4	6							
24	U249401	Grifo CAL-3200 (min. 0,55)		1	2	3							Para quemador 4000
24	U249402	Grifo CAL-3200 (min. 0,90)		1	1	2							Para quemador 8000
24	U702101	Grifo CAL-3200 (min. 1,30)		-	1	1							Para quemador 10500
25	U055043	Bicono Ø12		2	4	6							
26	Q221336	Tuerca M-18x1,5 (Para tubo Ø12)		2	4	6							



N plano	Firma	Fecha	Aparato	Lamina	Fagor Industrial S.Coop.	FAGOR 
C-885		11-00	COCINAS CG9-41, 61, 82	5	Ocate	

ITEM	CODIGO	DENOMINACION	TEXTO	CG9-41	CG9-61	CG9-82							NOTAS
1	Q221342	Remache exagonal M-5		2	2	4							
2	Q152004	Tornillo aplastado M-5x13		2	2	4							
3	U595050	Tubo distribuidor general		1	-	2							
3	U585060	Tubo distribuidor general		-	1	-							
4	U264310	Manguito 3/8"		1	1	2							
5	U055043	Bicono Ø12		1	1	2							
6	U264315	Valvula minisit completa		1	1	2							
	U134324	Cuerpo valvula		1	1	2							
	U134317	Boton de mando		1	1	2							
	U134318	Cubierta		1	1	2							
	U264300	Racord 3/8"		2	2	4							
	Q031322	Tornillo alomado M-4x15		8	8	16							
	Q307041	Junta torica Ø25,4xØ20,2xØ2,6		2	2	4							
	U264398	Bulbo termostato horno		1	1	2							
	U264399	Grupo electromagnetico		1	1	2							
7	Q012032	Tornillo exagonal M-5x15		2	2	4							
8	Q221304	Remache redondo M-5		2	2	4							
9	U322118	Piloto completo		1	1	2							
	U442138	Inyector piloto Ø0,25 (B.P.y G.V.)		1	1	2							Regular para G.V.
	U442137	Inyector piloto Ø0,40 (Gas Natural))		1	1	2							
10	Q012031	Tornillo exagonal M-5x10		2	2	4							
11	X012101	Bujia de encendido		1	1	2							
12	U323030	Cable bujia a piezoelectrico		1	1	2							
13	U333003	Cable masa a piezoelectrico		1	1	2							
14	S113034	Piezoelectrico		1	1	2							
15	U134323	Racord con bicono Ø6		1	1	2							
16	U562130	Termopar L=850		1	1	2							
17	U565036	Conduccion a piloto de horno		1	1	2							
18	Q162040	Tuerca exagonal M-6		2	2	4							

MOD.

COCINAS

PARTE FUNCIONAL GAS

PLANO

C-885

ITEM	CODIGO	DENOMINACION	TEXTO	CG9-41	CG9-61	CG9-82							NOTAS
19	U565620	Soporte valvula minisit		1	1	2							
20	Q223019	Tuerca exagonal 3/8"		1	1	2							
21	Q153002	Tornillo toma presion		1	1	2							
22	Q302022	Arandela plana Ø16xØ6x1,2		2	2	4							
23	Q011348	Tornillo exagonal M-6x60		2	2	4							
24	U565024	Conduccion a quemador horno		1	1	2							
25	U134323	Racord con bicono Ø6		1	1	2							
26	U055043	Bicono Ø12		1	1	2							
27	U264310	Manguito 3/8"		1	1	2							
28	U565023	Tubo entrada a valvula		1	1	2							
29	U565007	Codo entrada gas		1	1	2							
30	U725006	Tuerca 3/4"		1	1	2							
31	Q306052	Arandela junta Ø23,5xØ15,5x3		1	1	2							
32	Q411304	Remache avibulb Ø4,8		1	1	2							
33	Q221334	Tuerca 1/2"		1	1	2							
34	U055043	Bicono Ø12		1	1	2							
35	U542101	Boton de mando Ø10		4	6	8							
36	U565034	Tubo piloto anterior izquierdo		1	1	2							
37	U222130	Termopar anterior L=600		2	3	4							
38	U565027	Tubo a quemador anterior		2	3	4							
39	U565011	Tuerca guia quemad. 4000 y 8000		3	5	6							
40	U565032	Tubo piloto posterior izquierdo		1	1	2							
41	U565033	Tubo piloto anterior derecho		1	2	2							
42	Q153002	Tornillo toma presion		4	6	8							
43	U565029	Tubo a quemador posterior		2	3	4							
44	U235703	Tuerca guia quemador 10500		1	1	2							
45	U565031	Tubo piloto posterior derecho		1	2	2							
46	U262130	Termopar posterior L=1000		2	3	4							
47	U322109	Racord 1/8" (Para tubo Ø4)		4	6	8							

MOD.

COCINAS

PARTE FUNCIONAL GAS

PLANO

C-885

ITEM	CODIGO	DENOMINACION	TEXTO	CG9-41	CG9-61	CG9-82									NOTAS
48	U265026	Bicono Ø4		4	6	8									
49	U055043	Bicono Ø12		4	6	8									
50	Q221336	Tuerca M-18x1,5 (Para tubo Ø12)		4	6	8									
51	U249401	Grifo CAL-3200 (min. 0,55)		2	3	4									Para quemador 4000
51	U249402	Grifo CAL-3200 (min.0,90		1	2	2									Para quemador 8000
51	U702101	Grifo CAL-3200 (min. 1,30)		1	1	2									Para quemador 10500
52	U055043	Bicono Ø12		4	6	8									
53	Q221336	Tuerca M-18x1,5 (Para tubo Ø12)		4	6	8									

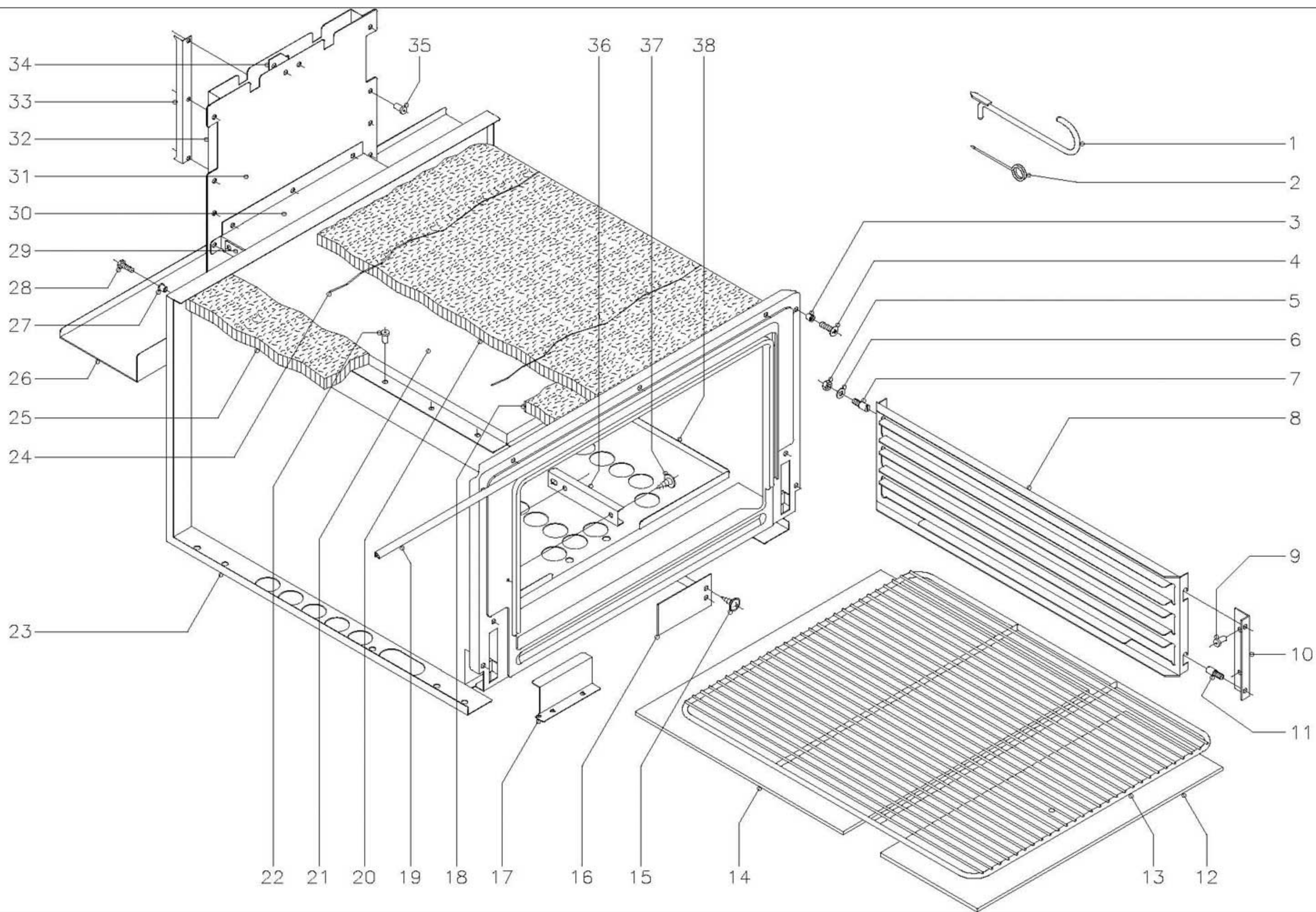

N plano	Firma	Fecha	Aparato	Lamina	Fagor Industrial S.Coop. FAGOR
C-886	<i>[Signature]</i>	11-00	COCINAS CG9-41, 61, 82	6	Ocate

MOD.		COCINAS		HORNO							PLANO	C-886
ITEM	CODIGO	DENOMINACION	TEXTO	CG9-41	CG9-61	CG9-82						NOTAS
1	0623600	Palanca levantaplacas horno		1	1	1						
2	0623500	Aguja limpieza quemadores		1	1	1						
3	Q221304	Remache redondo M-5		4	4	8						
4	Q152004	Tornillo aplastado M-5x13		4	4	8						
5	Q162040	Tuerca exagonal M-6		4	4	8						
6	Q302022	Arandela plana Ø16xØ6x1,2		4	4	8						
7	Q151336	Tornillo soporte guias		4	4	8						
8	U325608	Guia de bandejas		2	2	4						
9	Q419005	Remache tubular Ø4x8		4	4	8						
10	U325611	Escuadra soporte guia bandejas		2	2	4						
11	Q151336	Tornillo soporte guias		4	4	8						
12	U745630	Cabeza de placa de horno		1	1	2						
13	U135642	Parrilla de horno (651x531)		1	1	2						
14	U745631	Placa de horno		1	1	2						
15	Q151401	Tornillo alomado		2	2	4						
16	U325618	Tapa salida humos		1	1	2						
17	U742610	Protector quemador horno		1	1	2						
18	U745610	Vitrofib 390x70x20		1	1	2						
19	U745626	Junta puerta horno		1	1	2						
20	U325621	Vitrofib 1455x670x20		1	1	2						
21	U745613	Camara conduccion de humos		1	1	2						
22	Q419005	Remache tubular Ø4x8		17	17	34						
23	U745620	Cuerpo de horno		1	1	2						
24	-	Alambre amarre aislante		2	2	4						
25	R660530	Vitrofib 680x95x20		2	2	4						
26	U562656	Evacuacion calor mesa		1	1	2						
27	Q221321	Remache redondo M-6		2	2	4						
28	Q012043	Tornillo exagonal M-6x20		2	2	4						

MOD.

COCINAS



HORNO

PLANO

C-886

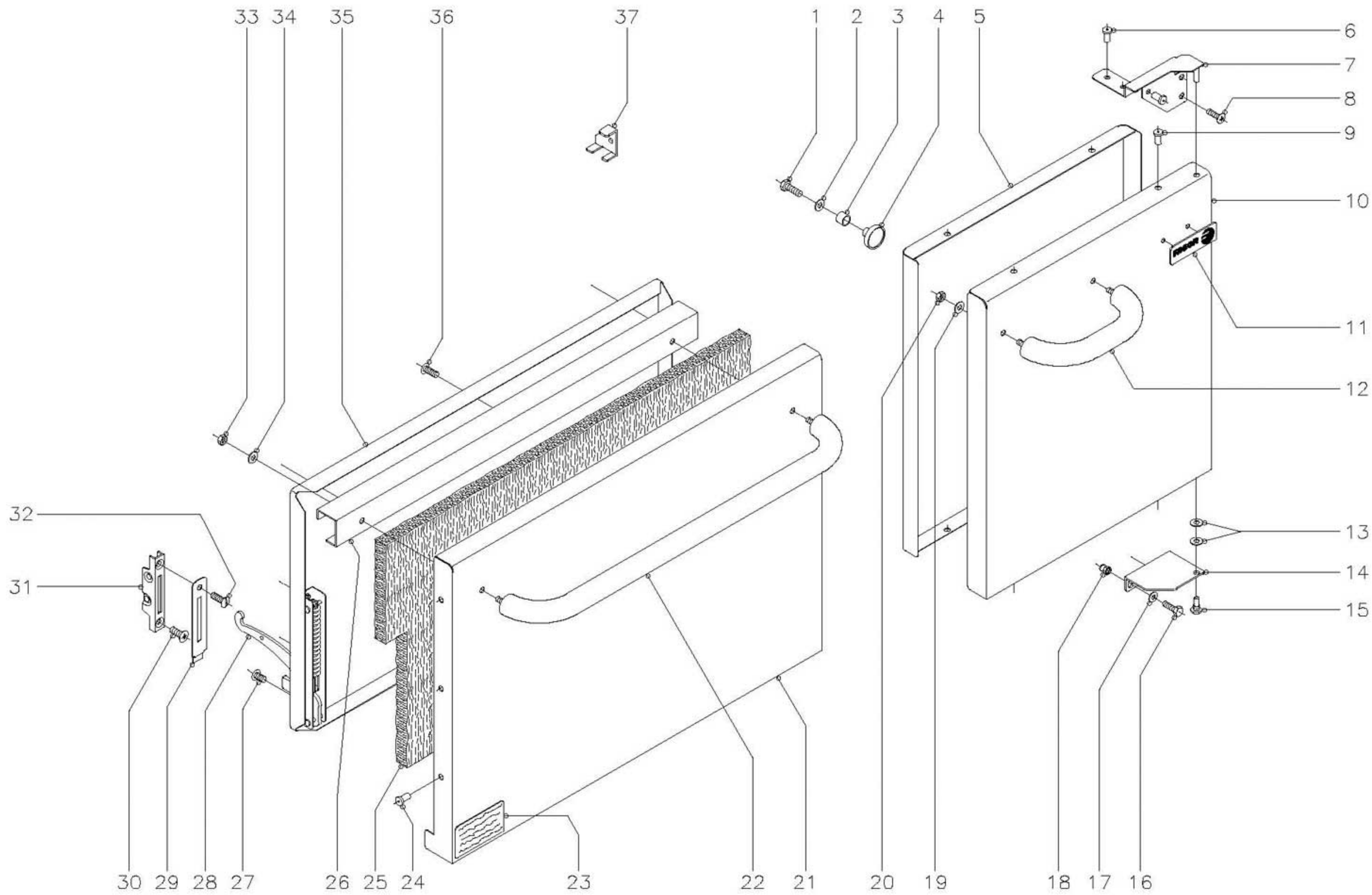
ITEM	CODIGO	DENOMINACION	TEXTO	CG9-41	CG9-61	CG9-82							NOTAS
29	U565610	Union chimenea inferior		1	1	2							
30	U565609	Union chimenea superior		1	1	2							
31	U745605	Anterior de chimenea		1	1	2							
32	U745606	Posterior de chimenea		1	1	2							
33	U565611	Distanciador de chimenea a panel		1	1	2							
34	U745607	Distanciador de chimenea		1	1	2							
35	Q419005	Remache tubular Ø4x8		18	18	36							
36	U055644	Conjunto fijacion bulbo		1	1	2							
37	Q151401	Tornillo alomado		2	2	4							
38	U565608	Base de horno		1	1	2							



N plano	Firma	Fecha	Aparato	Lamina	Fagor Industrial S.Coop.	FAGOR 
C-887		11-00	COCINAS CG9-41, 61, 82	7	0<ate	

MOD.

COCINAS

PUERTAS

PLANO

C-887

ITEM	CODIGO	DENOMINACION	TEXTO	CG9-41	CG9-61	CG9-82							NOTAS
1	Q012021	Tornillo exagonal M-4x10		-	2	-							
2	Q232020	Arandela plana A-4		-	2	-							
3	X960502	Fijacion iman		-	2	-							
4	X960501	Iman		-	2	-							
5	X160532	Contrapuerta		-	1	-							
6	Q419005	Remache tubular Ø4x8		-	3	-							
7	U582660	Bisagra superior derecha		-	1	-							
8	Q152004	Tornillo aplastado M-5x13		-	2	-							
9	Q419005	Remache tubular Ø4x8		-	4	-							
10	X160535	Puerta derecha		-	1	-							
11	U262806	Escudo FAGOR		1	1	1							
	Q221023	Clips sujecion escudo		2	2	2							
12	Z400540	Asa puerta de armario		-	1	-							
13	Q232040	Arandela plana A-6		-	2	-							
14	E022608	Bisagra inferior derecha		-	1	-							
15	X960504	Tornillo eje de giro M-8		-	1	-							
16	Q012043	Tornillo exagonal M-6x20		-	2	-							
17	Q302022	Arandela plana Ø16xØ6x1,2		-	2	-							
18	Q221343	Remache exagonal M-6		-	2	-							
19	Q302022	Arandela plana Ø16xØ6x1,2		-	2	-							
20	Q162030	Tuerca exagonal M-5		-	2	-							
21	U750500	Puerta de horno (Sin escudo)		-	1	1							
21	U740501	Puerta de horno (Con escudo)		1	-	1							
22	U560501	Asa puerta de horno		1	1	1							
23	S326540	Papel polyester placa matricula		1	1	1							
24	Q419005	Remache tubular Ø4x8		6	6	12							
25	U260502	Aislante vitrofib 680x380x20		1	1	2							
26	U320507	Refuerzo de puerta		1	1	2							
27	Q152022	Tornillo amarre M-6x8		6	6	12							

MOD.

COCINAS

PUERTAS

PLANO

C-887

ITEM	CODIGO	DENOMINACION	TEXTO	CG9-41	CG9-61	CG9-82								NOTAS
28	U010511	Bisagra izquierda		1	1	2								
s/n	U010504	Bisagra derecha		1	1	2								
29	U010510	Embellecedor guia bisagra		2	2	4								
30	Q042043	Tornillo avellanado M-6x20		2	2	4								
31	U010512	Guia de bisagra		2	2	4								
32	Q152017	Tornillo amarre M-6x13		2	2	4								
33	Q162030	Tuerca exagonal M-5		2	2	2								
34	Q302022	Arandela plana Ø16xØ6x1,2		2	2	2								
35	U260501	Contrapuerta de horno		1	1	2								
36	Q152017	Tornillo amarre M-6x13		3	3	6								
37	U746501	Escuadra montaje puerta		2	2	2								

MOD.

COCINAS

VARIOS

PLANO

ITEM

CODIGO

DENOMINACION

TEXTO

CG9-20

CG9-40

CG9-60

CG9-41

CG9-61

CG9-82

NOTAS

U566553

Folleto de instrucciones

1

1

1

1

1

1

ITEM	CODIGO	DENOMINACION	TEXTO	CG9-20	CG9-40	CG9-60	CG9-41	CG9-61	CG9-82				NOTAS
		<u>BUTANO - PROPANO</u>											
3	U122407	Tobera Ø1,05 (4000)		1	2	3	2	3	4				C-883
9 y 10	U442138	Inyector pilotos Ø0,25		2	4	6	5	7	10				C-885 y C-883
13	0631000	Tobera Ø1,40 (8000)		1	1	2	1	2	2				C-883
17	U112401	Tobera Ø1,55 (10500)		-	1	1	1	1	2				C-883
37	U052401	Tobera Ø1,45 (Horno)		-	-	-	1	1	2				C-883
s/n	U136501	Indicador (Butano - Propano)		1	1	1	1	1	1				
		<u>GAS NATURAL</u>											
3	9105100	Tobera Ø1,50 (4000)		1	2	3	2	3	4				C-883
9 y 10	U442137	Inyector pilotos Ø0,40		2	4	6	5	7	10				C-885 y C-883
13	R614500	Tobera Ø2,00 (8000)		1	1	2	1	2	2				C-883
17	R275050	Tobera Ø2,35 (10500)		-	1	1	1	1	2				C-883
37	1011600	Tobera Ø2,25 (Horno)		-	-	-	1	1	2				C-883
s/n	U134402	Indicador (Gas Natural)		1	1	1	1	1	1				
		<u>GAS VILLA</u>											
3	R302401	Tobera Ø2,90 (4000)		1	2	3	2	3	4				C-883
9 y 10	U442138	Inyector pilotos Ø0,25 (Regular)		2	4	6	5	7	10				C-885 y C-883
13	U262401	Tobera Ø4,10 (8000)		1	1	2	1	2	2				C-883
17	U192402	Tobera Ø4,90 (10500)		-	1	1	1	1	2				C-883
37	9424600	Tobera Ø4,23 (Horno)		-	-	-	1	1	2				C-883
s/n	U134310	Indicador (Gas Villa)		1	1	1	1	1	1				