

---

# DESPIECES DEL SERVICIO TECNICO

---

**Cocina con fry-top - Fourneau avec fry-top  
Range with fry-top - Gas Herde mit Griddleplatten**

**Mod.**

**CG9-51 L**

**CG9-51 R**

**CG9-51 CL**

**CG9-51 CR**

**NOVIEMBRE 1999**

**FAGOR**



Fagor Industrial, S. Coop.

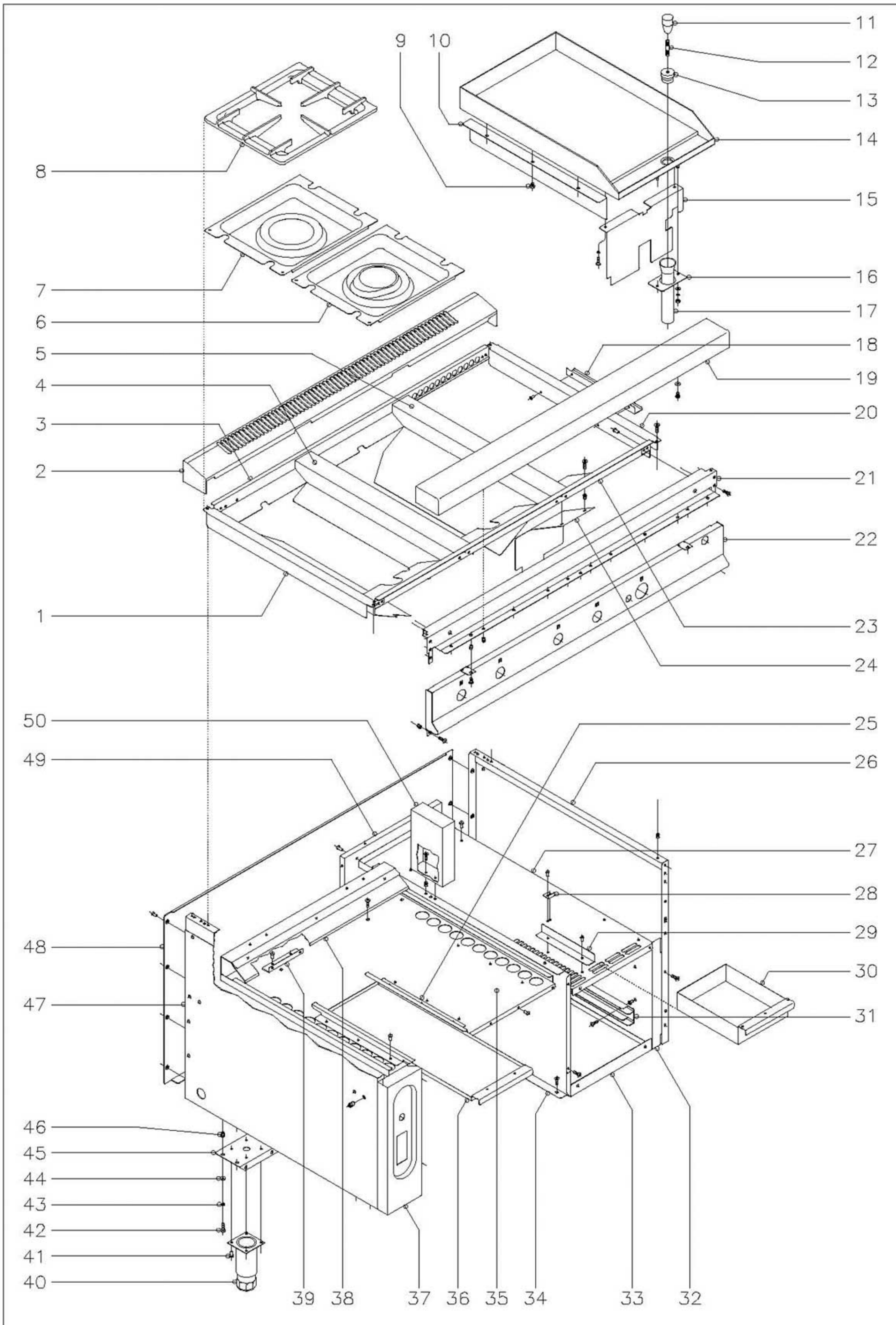

MOD.

COCINA

ZONA

MUEBLE

PLANO

C-756

ITEM	CODIGO	DENOMINACION	TEXTO	CG9-51									NOTAS
1	U565451	Lateral izquierdo de mesa		1									
	Q152004	Tornillo aplastado M-5x13		2									
	Q221342	Remache exagonal M-5		2									
	Q419005	Remache tubular Ø 4x8		4									
2	U845400	Embellecedor bajo 1 1/2 M.		1									
3	U845401	Posterior interior de mesa		1									
4	U565454	Central de mesa		1									
	Q419005	Remache tubular Ø 4x8		6									
5	U845403	Central derecho de mesa		1									
	Q419005	Remache tubular Ø 4x8		6									
6	U505408	Vertedero 4000		2									
7	U505409	Vertedero 6000, 8000 y 10000		2									
8	U565403	Parrilla		4									
9	R165414	Apoyo lateral		6									
10	R152611	Liston lateral		2									
11	S116122	Mando pomo		1									( SOLO CROMODURO )
12	R619913	Alargadera		1									( SOLO CROMODURO )
13	R619912	Tapon rebosadero		1									( SOLO CROMODURO )
14	R155435	Plancha lisa		1									
14	R155438	Plancha lisa cromo duro		1									
14	R155437	Plancha rayada		1									
14	R155439	Plancha rayada cromo duro		1									
15	R152613	Liston cubierta grifos		1									
	Q262040	Arandela muelle A-6		2									
	Q012042	Tornillo exagonal M-6x15		2									
16	R152607	Soporte tubo desagüe		1									
	Q302022	Arandela plana Ø 16x6x1,2		2									
	Q262040	Arandela muelle A-6		2									
	Q162040	Tuerca exagonal M-6		2									

MOD.		COCINA		ZONA		MUEBLE				PLANO		C-756	
ITEM	CODIGO	DENOMINACION	TEXTO	CG9-51									NOTAS
17	R155010	tubo desagüe		1									
18	R152601	Tirante lateral		1									
	Q419005	Remache tubular Ø 4x8											
19	U585451	Anterior de mesa 1 1/2		1									
	Q221342	Remache exagonal M-5		3									
	Q152004	Tornillo aplastado M-5x13		3									
20	R152807	Lateral de mesa		1									
	Q152004	Tornillo aplastado M-5x13		2									
	Q221342	Remache exagonal M-5		2									
	Q419005	Remache tubular Ø 4x8		4									
21	U582655	Escuadra amarre anterior mesa		1									
	Q152004	Tornillo aplastado M-5x13		6									
	Q221342	Remache exagonal M-5		6									
22	U842800	Panel portamandos		1									
22	U842802	Panel portamandos		1									
	Q152004	Tornillo aplastado M-5x13		4									
	Q221342	Remache exagonal M-5		4									
23	U845402	Anterior interior de mesa		1									
24	U842607	Chapa proteccion termostato		1									
	Q221342	Remache exagonal M-5		2									
	Q152004	Tornillo aplastado M-5x13		2									
25	U562640	Guia bandejas		4									
	Q419005	Remache tubular Ø 4x8		12									
26	X162811	Panel lateral derecho		1									
27	U842605	Techo lateral		1									
	Q419005	Remache tubular Ø 4x8		3									
28	R202607	Escuadra tope caja		1									
	Q419005	Remache tubular Ø 4x8		2									
29	R612702	Guia recoge grasas		2									

MOD.	COCINA		ZONA	MUEBLE					PLANO			C-756	
ITEM	CODIGO	DENOMINACION	TEXTO	CG9-51									NOTAS
	Q419005	Remache tubular Ø 4x8		4									
30	R152608	Caja recoge grasas		1									
31	U582665	Guia para bandejas 1/1		4									
	Q152004	Tornillo aplastado M-5x13		12									
	Q221342	Remache exagonal M-5		12									
32	U842601	Panel lateral interior derecho		1									
	Q152004	Tornillo aplastado M-5x13		2									
	Q221342	Remache exagonal M-5		2									
33	U842602	Base interior lateral		1									
		Remache tubular Ø 4x8		4									
34	U582656	Panel lateral interior izquierdo		1									
	Q152004	Tornillo aplastado M-5x13		2									
	Q221342	Remache exagonal M-5		2									
35	U562651	Base de bandejas		1									
	Q419005	Remache tubular Ø 4x8		3									
	Q152004	Tornillo aplastado M-5x13		2									
36	U722604	Bandeja recoge grasas		2									
37	U562854	Portamandos lateral		1									
	Q152004	Tornillo aplastado M-5x13		2									
38	U562652	Suplemento base bandejas		1									
	Q419005	Remache tubular Ø 4x8		3									
39	U325611	Escuadra tope bandejas		2									
	Q419005	Remache tubular Ø 4x8		4									
40	X260150	Pata regulable		4									
41	Q411304	Remache avibulb Ø 4,8		16									
42	Q012043	Tornillo exagonal M-6x20		8									
43	Q262040	Arandela muelle A-6		8									
44	Q302022	Arandela plana Ø 16xØ6x1,2		8									
45	U582652	Liston soporte patas		2									



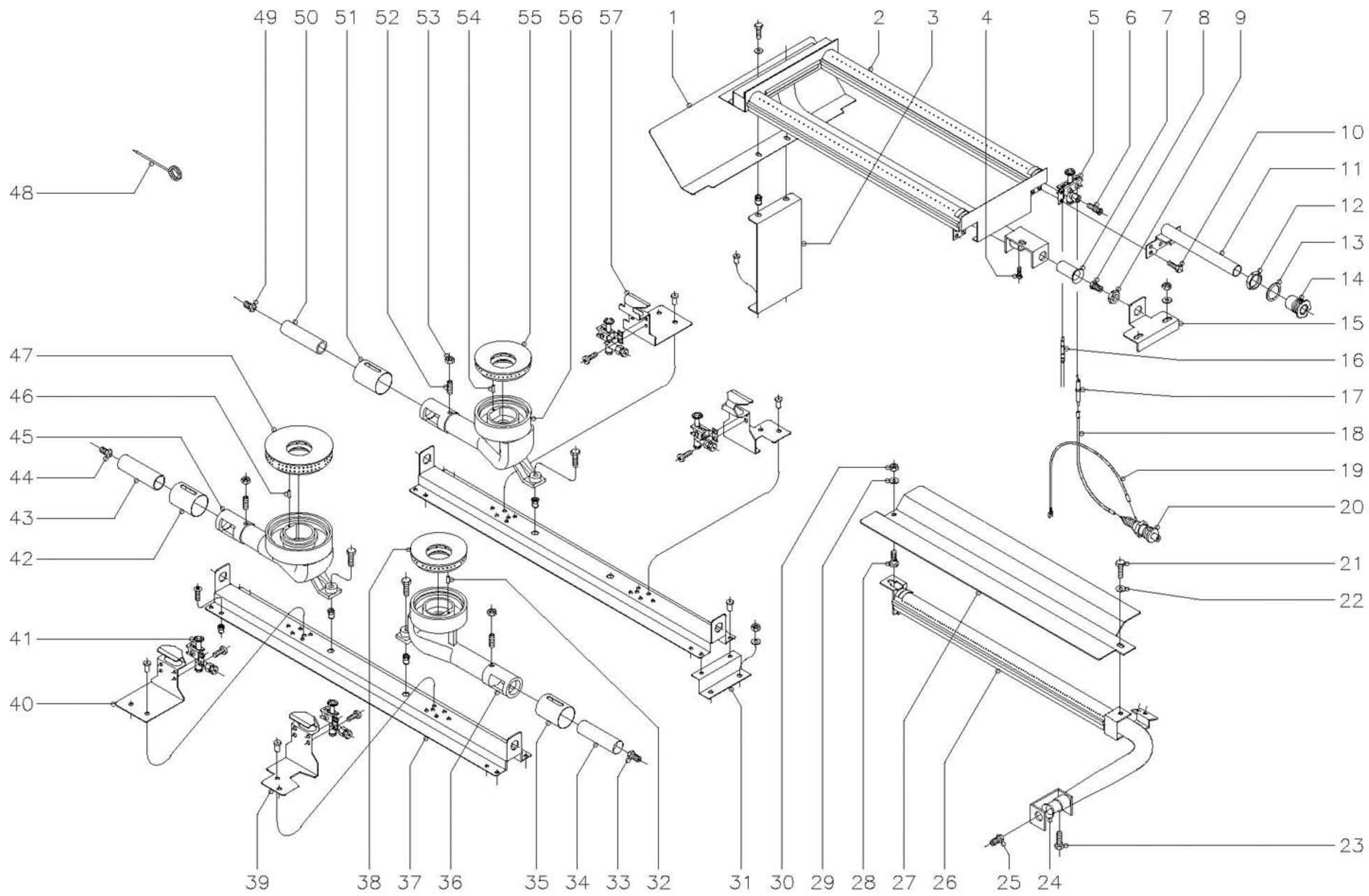

N plano	Firma	Fecha	Aparato	Lamina	Fagor Industrial S.Coop.	FAGOR
C-757		9-99	COCINA CG9-51	2	Olate	

MOD.

COCINA

ZONA

QUEMADORES

PLANO

C-757

ITEM	CODIGO	DENOMINACION	TEXTO	CG9-51									NOTAS
1	R152610	Conduccion de humos		1									
2	R635700	Quegador fry-top		1									
	Q012031	Tornillo exagonal M-5x10		2									
	Q302022	Arandela plana Ø 16xØ 6x1,2		2									
	Q221342	Remache exagonal M-5		2									
3	R162603	Soporte quemador		1									
	Q419005	Remache tubular Ø 4x8		2									
4	Q012042	Tornillo exagonal M-6x15		1									
5	U322118	Piloto completo		1									
6	U134323	Racord con bicono Ø 6		1									
7	U325707	Regulador de aire		1									
8	U112401	Tobera Ø 1,55 (But.-Prop.)		1									
8	9105100	Tobera Ø 1,50 (But.-Prop.) Cromod.		1									( SOLO CROMODURO )
8	1011600	Tobera Ø 2,25 ( Gas Natural )		1									
8	U262400	Tobera Ø 2,15 ( Gas Natural )Cromo		1									(SOLO CROMODURO )
9	Q223019	Tuerca exagonal 3/8		1									
10	Q012031	Tornillo exagonal M-5x10		2									
11	R165011	Tubo de encendido		1									
12	Q221324	Tuerca exagonal 3/4"		1									
13	Q306027	Arandela junta Ø 33,8xØ27x1,5		1									
14	S112804	Embellecedor tubo encendido		1									
15	U845007	Escuadra amarre quemador		1									
	Q302022	Arandela plana Ø 16xØ 6x1,2		2									
	Q162040	Tuerca exagonal M-6		2									
16	U562130	Termopar L = 850		1									
17	X012101	Bujia de encendido		1									
18	U323030	Cable bujia a piezoelectrico		1									
19	U333003	Cable masa a piezoelectrico		1									
20	S113034	Piezoelectrico		1									



MOD.												
COCINA			ZONA	QUEMADORES					PLANO	C-757		
ITEM	CODIGO	DENOMINACION	TEXTO	CG9-51								NOTAS
21	Q012041	Tornillo exagonal M-6x10		1								
22	Q302022	Arandela plana Ø 16xØ 6x1,2		1								
23	Q012031	Tornillo exagonal M-5x10		1								
24	U325707	Regulador de aire horno		1								
25	U052401	Tobera Ø 1,45 (B. P.) Horno		1								
25	9101160	Tobera Ø 2,25 (G. N.) Horno		1								
25	9424600	Tobera Ø 4,23 (G. V.) Horno		1								
26	U745700	Quemador horno		1								
27	U745705	Difusor quemador horno		1								
28	R252624	Piton soporte		1								
29	Q302022	Arandela plana Ø 16xØ 6x1,2		1								
30	Q162040	Tuerca exagonal M-6		1								
31	U562655	Escuadra soporte liston		2								
	Q302022	Arandela plana Ø 16xØ 6x1,2		4								
	Q162040	Tuerca exagonal M-6		4								
32	Q371026	Manguito Ø 4x14		2								
33	U122407	Tobera Ø 1,05 ( B. P.) 4000		2								
33	9105100	Tobera Ø 1,50 ( G. N.) 4000		2								
33	R302401	Tobera Ø 2,90 ( G. V.) 4000		2								
34	U125720	Venturi quemador 4000		2								
35	U265702	Regulador de aire 4000		2								
36	U445730	Cuerpo quemador 4000		2								
37	U562654	Liston amarre quemadores		2								
	Q419005	Remache tubular Ø 4x8		4								
	Q152004	Tornillo aplastado M-5x13		4								
	Q221342	Remache exagonal M-5		4								
38	U445731	Quemador 4000		2								
39	U505440	Soporte piloto 4000		2								
	Q419005	Remache tubular Ø 4x8		4								

MOD.

COCINA

ZONA

QUEMADORES

PLANO

C-757

ITEM	CODIGO	DENOMINACION	TEXTO	CG9-51															NOTAS
40	U445441	Soporte piloto 8000 y 10500		1															
	Q419005	Remache tubular Ø 4x8		2															
41	U442134	Conjunto piloto mesa		4															
	Q032021	Tornillo alomado M-4x10		8															
42	U235704	Regulador de aire 10500		1															
43	U235702	Venturi quemador 10500		1															
44	U112401	Tobera Ø 1,55 ( B. P.) 10500		1															
44	R275050	Tobera Ø 2,35 ( G. N.) 10500		1															
44	U192402	Tobera Ø 4,90 ( G. V.) 10500		1															
45	U235700	Cuerpo quemador 10500		1															
46	Q371028	Manguito Ø 3x14		2															
47	U235701	Quemador 10500		1															
48	6235000	Aguja limpieza quemadores		1															
49	0631000	Tobera Ø 1,40 ( B. P.) 8000		1															
49	R614500	Tobera Ø 2,00 ( G. N.) 8000		1															
49	U262401	Tobera Ø 4,10 ( G. V.) 8000		1															
50	U565700	Venturi quemador 8000		1															
51	U265702	Regulador de aire 8000		1															
52	Q131542	Varilla roscada M-6x15		4															
53	Q162040	Tuerca exagonal M-6		4															
54	Q371026	Manguito Ø 4x14		1															
55	U135702	Quemador 8000		1															
56	U565701	Cuerpo quemador 8000		1															
	Q012044	Tornillo exagonal M-6x25		4															
	Q221343	Remache exagonal M-6		4															
57	U445441	Soporte piloto 8000 y 10500		1															
	Q419005	Remache tubular Ø 4x8		2															

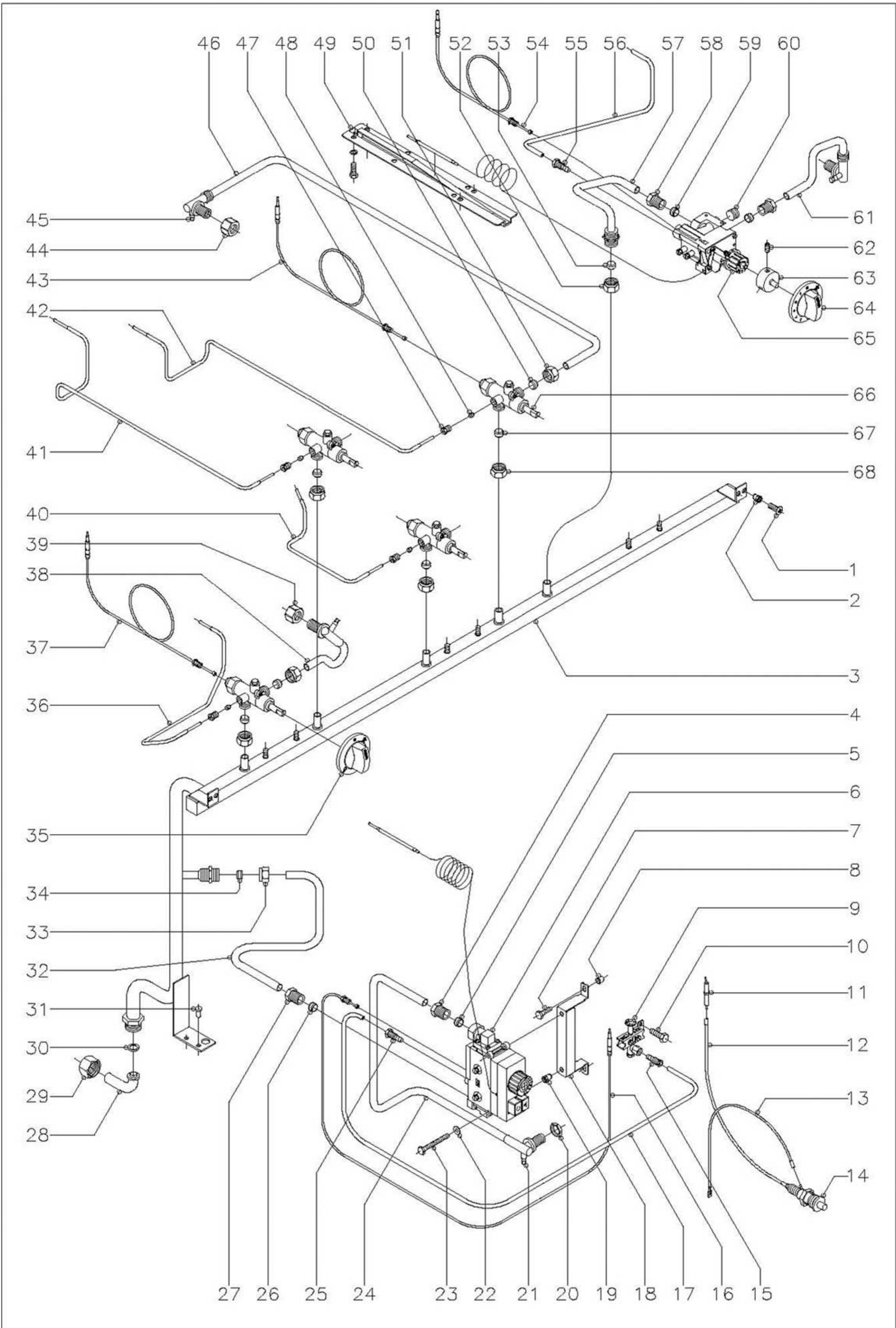

MOD.

COCINA

ZONA

PARTE FUNCIONAL GAS

PLANO

C-758

ITEM	CODIGO	DENOMINACION	TEXTO	CG9-51																NOTAS
1	Q152004	Tornillo aplastado M-5x13		2																
2	Q221342	Remache exagonal M-5		2																
3	U845000	Tubo distribuidor general		1																
4	U264310	Manguito 3/8		1																
5	U055043	Bicono Ø 12		1																
6	U264315	Valvula minisit completa		1																
	U134316	Cuerpo valvula		1																
	U134317	Mando negro		1																
	U134318	Cubierta		1																
	U264300	Racord 3/8"		2																
	Q031322	Tornillo alomado M-4x15		8																
	Q307041	Junta torica Ø 25,4xØ 20,2xØ 2,6		2																
	U264398	Bulbo termostato horno		1																
	U264399	Grupo electromagnetico		1																
7	Q012032	Tornillo exagonal M-5x15		2																
8	Q221304	Remache redondo M-5		2																
9	U322118	Piloto completo		1																
10	Q012031	Tornillo exagonal M-5x10		2																
11	X012101	Bujia de encendido		1																
12	U323030	Cable bujia a piezoelectrico		1																
13	U333003	Cable masa a piezoelectrico		1																
14	S113034	Piezoelectrico		1																
15	U134323	Racord con bicono Ø 6		1																
16	U562130	Termopar L=850		1																
17	U565036	Conduccion a piloto de horno		1																
18	U565620	Soporte valvula minisit		1																
19	Q221343	Remache exagonal M-6		2																
20	Q223019	Tuerca exagonal 3/8"		1																
21	Q153002	Tornillo toma presion		1																

MOD.

COCINA

ZONA

PARTE FUNCIONAL GAS

PLANO

C-758

ITEM	CODIGO	DENOMINACION	TEXTO	CG9-51															NOTAS
22	Q302022	Arandela plana Ø 16xØ 6x1,2		2															
23	Q011348	Tornillo exagonal M-6x60		2															
24	U565024	Conduccion a quemador de horno		1															
25	U134323	Racord con bicono Ø 6		1															
26	U055043	Bicono Ø 12		1															
27	U264310	Manguito 3/8"		1															
28	U725005	Codo entrada gas		1															
29	U725006	Tuerca 3/4"		1															
30	Q306012	Arandela junta Ø 18xØ 13x1,5		1															
31	Q411304	Remache avibulb Ø 4,8		2															
32	U565023	Tubo entrada a valvula		1															
33	Q221334	Tuerca 1/2"		1															
34	U055043	Bicono Ø 12		1															
35	U542100	Boton de mando Ø 10		4															
36	U565034	Tubo piloto anterior izquierdo		1															
37	U222100	Termopar anterior L=600		2															
38	U565027	Tubo a quemador anterior		2															
39	U565011	Tuerca guia quemador 4000 y 8000		2															
40	U565033	Tubo piloto anterior derecho		1															
41	U565032	Tubo piloto posterior izquierdo		1															
42	U565031	Tubo piloto posterior derecho		1															
43	U262103	Termopar posterior L=1000		2															
44	U565011	Tuerca guia quemador 4000 y 8000		1															
44	U235703	Tuerca guia quemador 10500		1															
45	Q153002	Tornillo toma presion		4															
46	U565029	Tubo a quemador posterior		2															
47	U322109	Racord 1/8 ( Para tubo Ø 4 )		4															
48	U265026	Bicono Ø 4		4															
49	R162630	Conjunto soporte bulbo		1															

MOD.

COCINA

ZONA

PARTE FUNCIONAL GAS

PLANO

C-758

ITEM	CODIGO	DENOMINACION	TEXTO	CG9-51																	NOTAS
	Q242030	Arandela muelle A-5		4																	
	Q012032	Tornillo exagonal M-5x15		4																	
50	U055043	Bicono Ø 12		4																	
51	Q221336	Tuerca M-18x1,5 ( Para tubo Ø 12 )		4																	
52	Q221334	Tuerca 1/2"		1																	
53	U055043	Bicono Ø 12		1																	
54	U562130	Termopar L=850		1																	
55	U134323	Racord con bicono Ø 6		1																	
56	U845006	Tubo piloto fry-top		1																	
57	U845004	Tubo entrada a Eurosit		1																	
58	U264310	Manguito 3/8"		2																	
59	U055043	Bicono Ø 12		2																	
60	T982102	Tapon 3/8"		2																	
61	U845002	Tubo salida de Eurosit a quemador		1																	
62	Q131502	Varilla roscada M-5x6		3																	
63	U842100	Suplemento para Eurosit		1																	
64	U842101	Boton de mando Ø 8		1																	
65	T982100	Valvula 630 Eurosit		1																	
66	U249401	Grifo CAL-3200 (min. 0,55)		2																	
66	U249402	Grifo CAL-3200 (min. 0,90)		1																	
66	U702101	Grifo CAL-3200 (min. 1,30)		1																	
67	U055043	Bicono Ø 12		4																	
68	Q221336	Tuerca M-18x1,5 ( Para tubo Ø 12 )		4																	

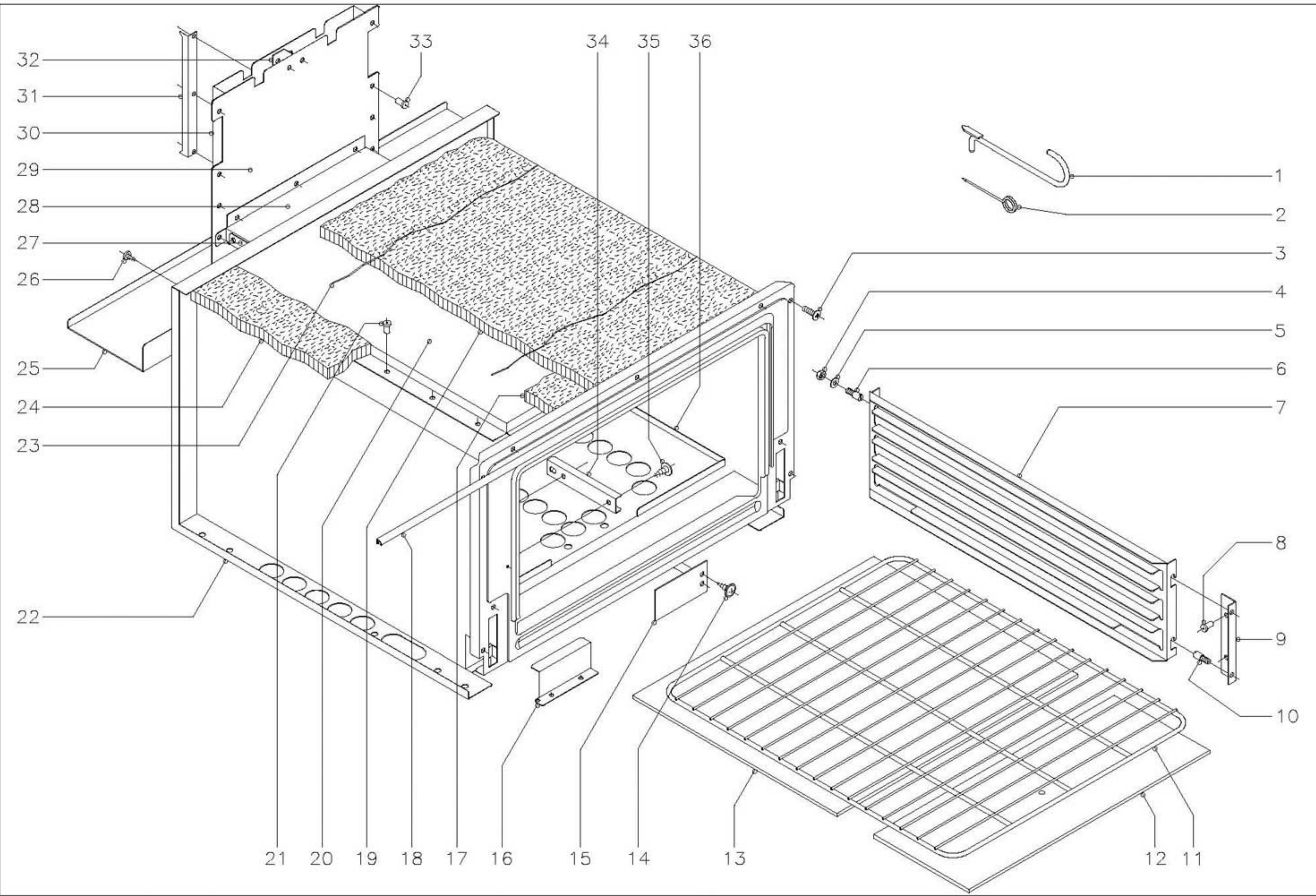

N plano	Firma	Fecha	Aparato	Lamina	Fagor Industrial S.Coop. <b>FAGOR</b>
C-759		9-99	COCINA CG9-51	4	Ocate

MOD.

COCINA

ZONA

HORNO

PLANO

C-759

ITEM	CODIGO	DENOMINACION	TEXTO	CG9-51																NOTAS
1	0623600	Palanca levantaplacas		1																
2	0623500	Aguja limpieza quemadores		1																
3	Q152004	Tornillo aplastado M-5x13		4																
	Q221304	Remache redondo M-5		4																
4	Q162040	Tuerca exagonal M-6		4																
5	Q302022	Arandela plana Ø 16xØ 6x1,2		4																
6	Q151336	Tornillo soporte guias		4																
7	U325608	Guia de bandejas		2																
8	Q419005	Remache tubular Ø 4x8		4																
9	U325611	Escuadra soporte guia bandejas		2																
10	Q151336	Tornillo soporte guias		4																
11	U135635	Parrilla de horno		1																
12	U745630	Cabeza placa de horno		1																
13	U745631	Placa de horno		1																
14	Q151401	Tornillo alomado		2																
15	U325618	Tapa salida humos		1																
16	U742610	Protector quemador horno		1																
17	U745610	Vitrofib 390x70x20		1																
18	U745626	Junta puerta horno		1																
19	U325621	Vitrofib 1455x670x20		1																
20	U745613	Camara conduccion de humos		1																
21	Q419005	Remache tubular Ø 4x8		17																
22	U745620	Cuerpo de horno		1																
23	-	Alambre amarre aislante		2																
24	R660530	Vitrofib 680x95x20		2																
25	U562656	Evacuacion calor mesa		1																
26	Q081365	Tornillo alomado 4,8x19		2																
27	U565610	Union chimenea inferior		1																
28	U565609	Union chimenea superior		1																





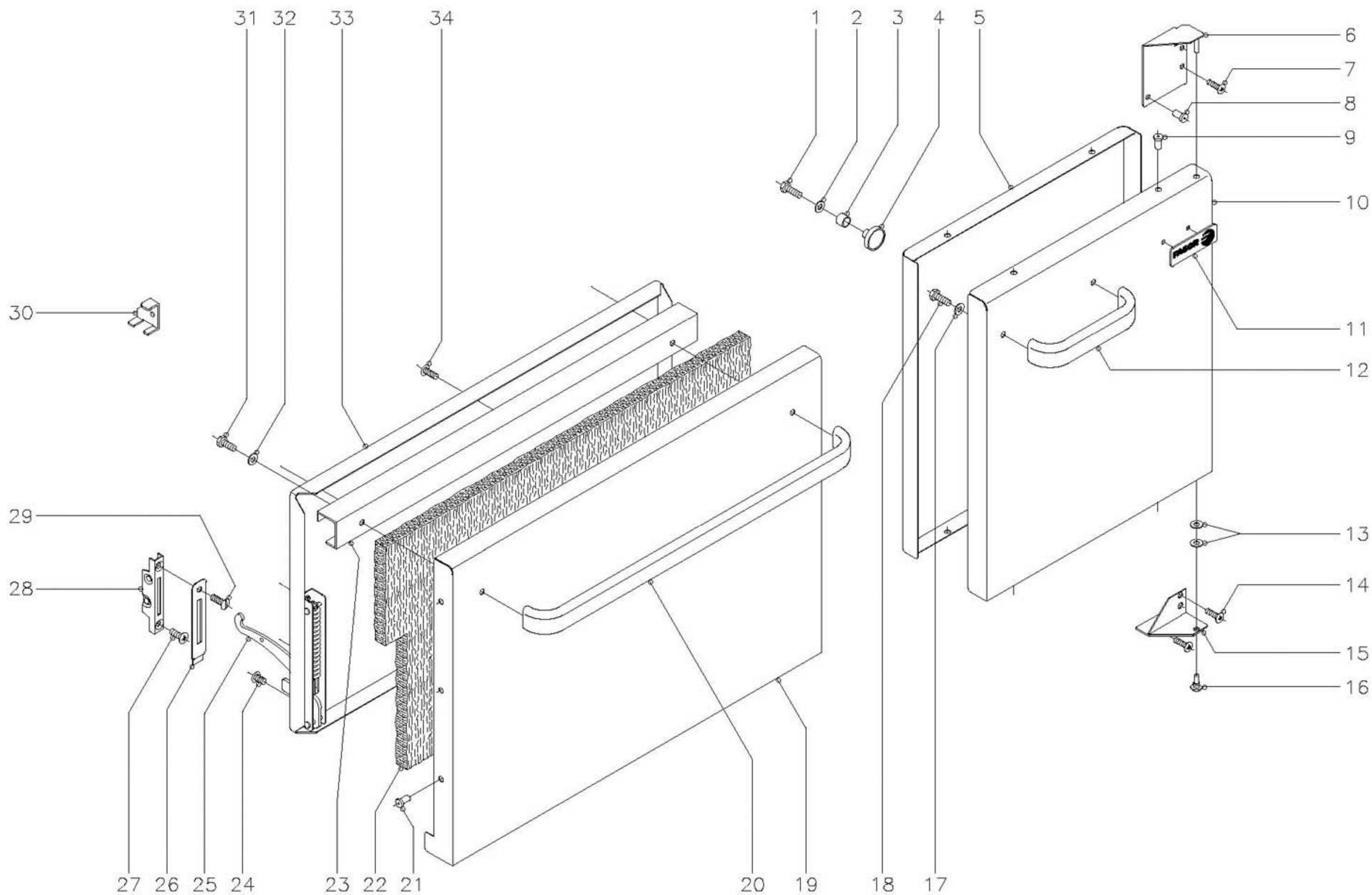

N plano C-760	Firma 	Fecha 9-99	Aparato COCINA CG9-51	Lamina 5	Fagor Industrial S.Coop. <b>FAGOR</b>
------------------	-----------	---------------	--------------------------	-------------	---------------------------------------

MOD.

COCINA

ZONA

PUERTAS

PLANO

C-760

ITEM	CODIGO	DENOMINACION	TEXTO	CG9-51										NOTAS
1	Q012021	Tornillo exagonal M-4x10		2										
2	Q232020	Arandela plana A-4		2										
3	X960502	Fijacion iman		2										
4	X960501	Iman		2										
5	X160532	Contrapuerta		1										
6	U842603	Bisagra superior derecha		1										
7	Q152004	Tornillo aplastado M-5x13		2										
8	Q419005	Remache tubular Ø 4x8		1										
9	Q419005	Remache tubular Ø 4x8		4										
10	X160531	Puerta derecha		1										
11	U262806	Escudo FAGOR		1										
	Q221023	Clips sujecion escudo		2										
12	U580521	Asa puerta		1										
13	Q232040	Arandela plana A-6		2										
14	Q152004	Tornillo aplastado M-5x13		3										
15	U582662	Bisagra inferior derecha		1										
16	X960504	Tornillo de giro M-8		1										
17	Q302022	Arandela plana Ø 16xØ 6x1,2		2										
18	Q012041	Tornillo exagonal M-6x10		2										
19	U750500	Puerta de horno		1										
20	U580520	Asa puerta horno		1										
21	Q419005	Remache tubular Ø 4x8		6										
22	U260502	Aislante vitrofib 680x380x20		1										
23	U320507	Refuerzo de puerta		1										
24	Q152022	Tornillo amarre M-6x8		6										
25	U010511	Bisagra izquierda		1										
S/N	U010504	Bisagra derecha		1										
26	U010510	Embellecedor guia bisagra		2										
27	Q042043	Tornillo alomado M-6x20		2										



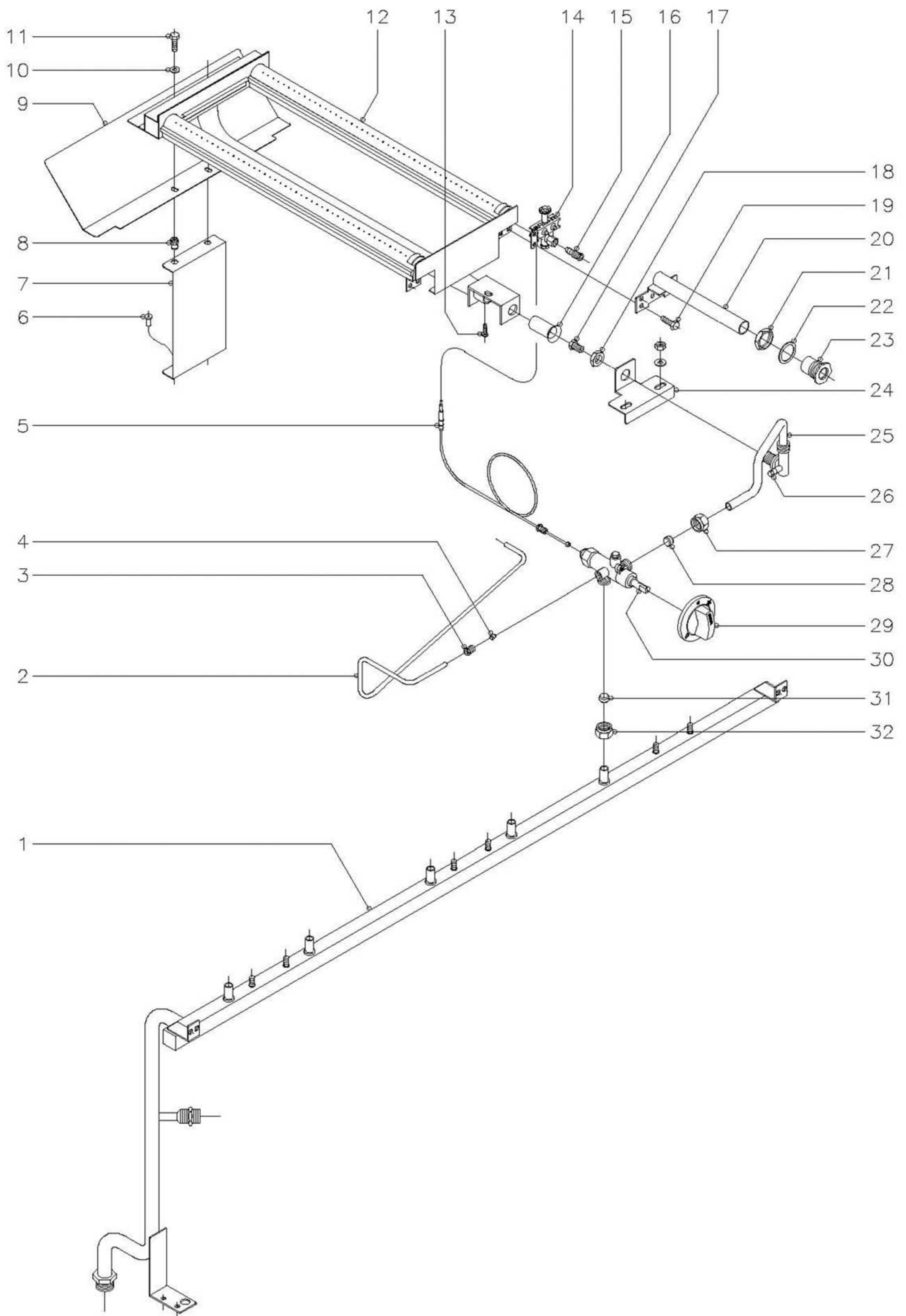

N plano  
C-761

Firma  
*[Signature]*

Fecha  
9-99

Aparato  
COCINA CG9-51 (GAS VILLA)

Lamina  
6

Fagor Industrial S.Coop.  
D<ate



MOD.		COCINA		ZONA	PARTE FUNCIONAL A GAS VILLA EN FRY-TOP					PLANO	C-761	
ITEM	CODIGO	DENOMINACION	TEXTO	CG9-51								NOTAS
1	U845008	Tubo distribuidor general		1								
2	U845012	Tubo piloto		1								
3	U322109	Racord 1/8" ( Para tubo Ø 4 )		1								
4	U265026	Bicono Ø 4		1								
5	U222100	Termopar L=500		1								
6	Q419005	Remache tubular Ø 4x8		2								
7	R162603	Soporte quemador		1								
8	Q221342	Remache exagonal M-5		2								
9	R152610	Conduccion de humos		1								
10	Q302022	Arandela plana Ø 16xØ 6x1,2		2								
11	Q012031	Tornillo exagonal M-5x10		2								
12	R635700	Quemador fry-top		1								
13	Q012042	Tornillo exagonal M-6x15		1								
14	U322118	Piloto completo		1								
15	U134323	Racord con bicono Ø 6		1								
16	U325707	Regulador de aire		1								
17	U842400	Tobera Ø 4,40		1								
18	Q223019	Tuerca exagonal 3/8"		1								
19	Q012031	Tornillo exagonal M-5x10		2								
20	R165011	Tubo de encendido		1								
21	Q221324	Tuerca exagonal 3/4"		1								
22	Q306027	Arandela junta Ø 33,8x27x1,5		1								
23	S112804	Embellecedor tubo encendido		1								
24	U845007	Escuadra amarre quemador		1								
25	U845010	Conduccion grifo a quemador		1								
26	Q153002	Tornillo toma presion		1								
27	Q221336	Tuerca M-18x1,5 ( Para tubo Ø 12 )		1								
28	U055043	Bicono Ø 12		1								
29	U542100	Boton de mando Ø 10		1								







MOD.

COCINA

ZONA

PIEZAS ESPECIFICAS PARA LOS  
DISTINTOS GASES

PLANO

C-756  
C-757 C-761

ITEM	CODIGO	DENOMINACION	TEXTO	CG9-51									NOTAS
		<b><u>BUTANO - PROPANO</u></b>											
8	U112401	Tobera Ø 1,55 ( Fry-top )		1									( C-757 )
8	9105100	Tobera Ø 1,50 ( Fry-top )		1									(C-757) ( CROMODURO )
24	U052401	Tobera Ø 1,45 ( Horno )		1									( C-757 )
32	U122407	Tobera Ø 1,05 ( 4000 )		2									( C-757 )
43	U112401	Tobera Ø 1,55 ( 10500 )		1									( C-757 )
48	0631000	Tobera Ø 1,40 ( 8000 )		1									( C-757 )
	U136501	Indicador ( But. Pro. )		1									
		<b><u>GAS NATURAL</u></b>											
8	1011600	Tobera Ø 2,25 ( Fry-top )		1									( C-757 )
8	U262400	Tobera Ø 2,15 ( Fry-top )		1									(C-757) ( CROMODURO )
24	9101160	Tobera Ø 2,25 ( Horno )		1									( C-757 )
32	9105100	Tobera Ø 1,50 ( 4000 )		2									( C-757 )
43	R275050	Tobera Ø 2,35 ( 10500 )		1									(C-757)
48	R614500	Tobera Ø 2,00 ( 8000 )		1									( C-757 )
	U134402	Indicador ( Gas Natural )		1									
		<b><u>GAS VILLA</u></b>											
17	U842400	Tobera Ø 4,40 ( Fry-top )											( C-761 )
-	-	( NO HAY VERSION CROMODURO )		-									
24	9424600	Tobera Ø 4,23 ( Horno )		1									( C-757 )
32	R302401	Tobera Ø 2,90 ( 4000 )		2									( C-757 )
43	U192402	Tobera Ø 4,90 ( 10500 )		1									( C-757 )
48	U262401	Tobera Ø 4,10 ( 8000 )		1									( C-757 )
	U134310	Indicador ( Gas Villa )		1									
22	U842802	Panel portamandos ( Gas Villa )		1									( C-756 )