DESPIECE TECNICO

**Cocinas
Fourneaux
Ranges
Cucine
Fogões
Herde**

GAMA 900

Modelos:

CE9-20

CE9-40

CE9-41

Junio 2009 June

Revisado Septiembre 2010



Fagor Industrial

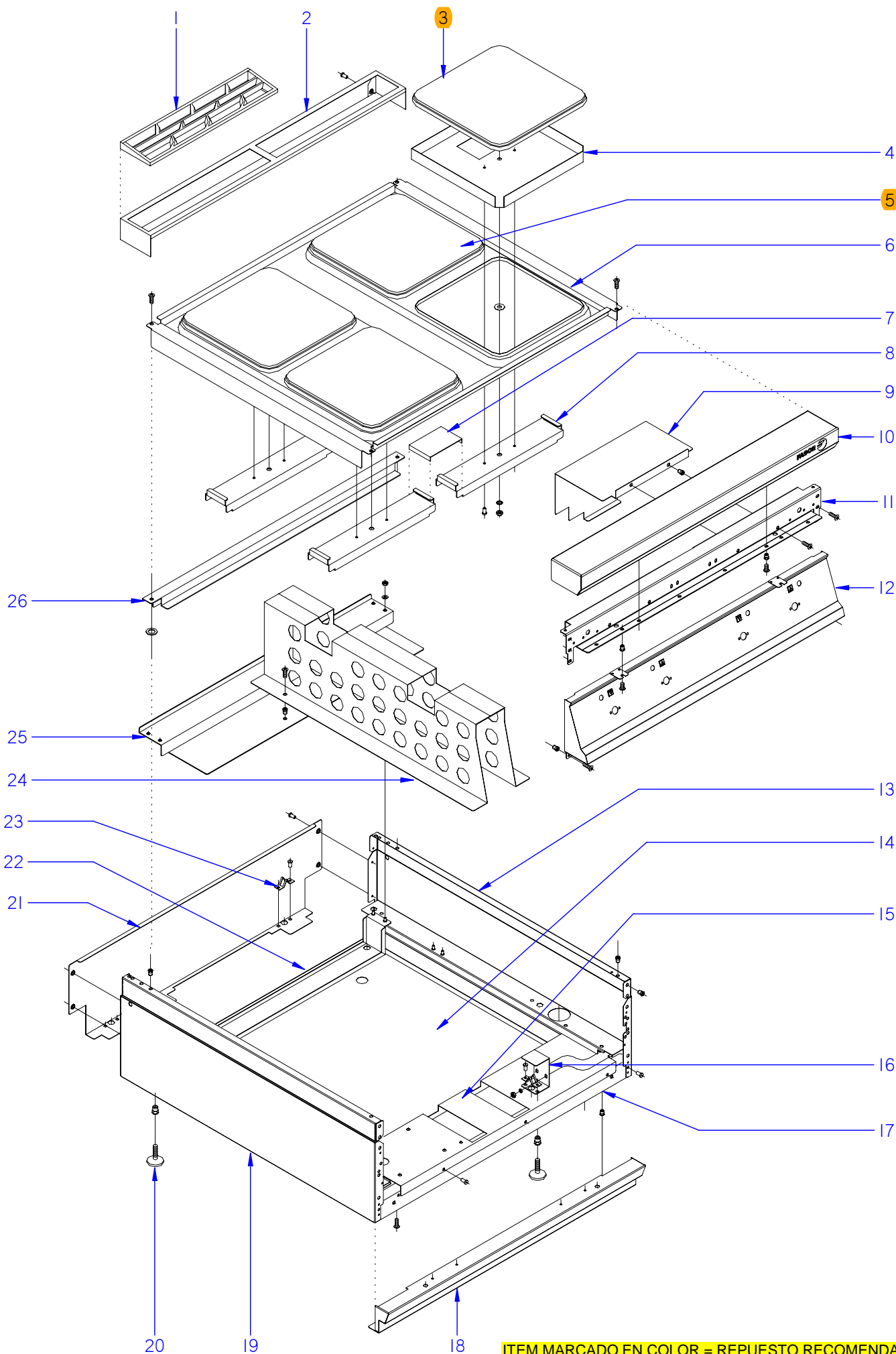

ITEM MARCADO EN COLOR = REPUESTO RECOMENDADO
 COLOURED ITEM = RECOMMENDED SPARE PART

N plano	Firma	Fecha	Aparato	MUEBLE	Lamina	Fagor Industrial S.Coop. FAGOR
C-1757	<i>(Signature)</i>	2007-01		COCINA CE9-40	1	Oñate

MOD.		COCINAS		ZONA	MUEBLE					PLANO	C-1757
ITEM	CODIGO	DENOMINACION	TEXTO	CE9-20	CE9-40						NOTAS
1	R205425000	EMBELLECEDOR ESMALTE	ENAMEL TRIM	1	2						
2	R205438000	SOPORTE EMBELLECEDOR 1/2 M	TRIM SUPPORT 1/2 M	1	—						
2	R205439000	SOPORTE EMBELLECEDOR 1 M	TRIM SUPPORT 1 M	—	1						
	Q419005000	REMACHE 4x8 ALMG3 / ALUMINIO	RIVET 4X8 ALMG3 / ALUMINIUM	2	2						
3	U673011000	PLACA 3000W 230V	PLATE 3000W 230V	1	3						
4	U675404000	CAZOLETA DE PLACAS	PLATE CASING	2	4						
	Q162050000	TUERCA EXAGONAL M8x1 INOX	HEXAGONAL NUT M8X1 INOX	2	4						
	Q262050000	ARANDELA GROW. A8 A304	WASHER GROW. A8 A.304	2	4						
	Q232050000	ARANDELA A8	WASHER A8	2	4						
5	U673010000	PLACA 4000W 230V	PLATE 4000W 230V	1	1						
6	U655450000	MESA DE 1/2 M	BENCH 1/2 M	1	—						
6	U675450000	MESA DE 1M	BENCH 1 M	—	1						
	Q152004000	TORNIL, APLASTADO M5x13 A304	FLAT HEADED BOLT M5x13 A304	4	4						
7	U675455000	APOYO PUENTE AMARRE PLACAS	PLATE FASTENING BRIDGE SUP	—	2						
8	U655404000	PUENTE AMARRE PLACAS	PLATE FASTENING BRIDGE	2	4						
9	U802602000	CHAPA PROTEC.COMUTADORAS	SWITCH PROTECTION PLATE	1	2						
	Q152004000	TORNIL, APLASTADO M5x13 A304	FLAT HEADED BOLT M5x13 A304	4	4						
	Q221341000	REMACHE EXAGONAL M 4	HEXAGONAL RIVET M4	1	1						
10	R045416000	ANTERIOR DE MESA 1/2 M	BENCH FRONT 1/2 M	1	—						
10	S105402000	ANTERIOR MESA 1 M	BENCH FRONT 1 M	—	1						
	Q152004000	TORNIL, APLASTADO M5x13 A304	FLAT HEADED BOLT M5x13 A304	2	2						
	Q302022000	ARANDELA 16x6x1,2 A304	WASHER 16x6x1,2 A304	2	2						
11	X162680000	ESCUADRA INTE. ANT. MESA 1/2M	BENCH FR. INT. BRACKET 1/2M	1	—						ELIMINADO 01.09.09
11	X162690000	ESCUADRA INTE. ANT. MESA 1/2M	BENCH FR. INT. BRACKET 1/2M	1	—						INTRODUCIDO 01.09.09
11	U022605000	ESCUADRA INTER. ANT. MESA 1M	BENCH FR. INT. BRACKET 1M	—	1						ELIMINADO 01.09.09
11	U022632000	ESCUADRA INTER. ANT. MESA 1M	BENCH FR. INT. BRACKET 1M	—	1						INTRODUCIDO 01.09.09
	Q221342000	REMACHE EXAGONAL M5	HEXAGONAL RIVET M5	3	2						
	Q152004000	TORNIL, APLASTADO M5x13 A304	FLAT HEADED BOLT M5x13 A304	6	6						
	Q221343000	REMACHE EXAGONAL M6	HEXAGONAL RIVET M6	2	2						
	Q302022000	ARANDELA 16x6x1,2 A304	WASHER 16x6x1,2 A304	4	4						
	Q221342000	REMACHE EXAGONAL M5	HEXAGONAL RIVET M5	4	4						

MOD.		COCINAS		ZONA	MUEBLE				PLANO	C-1757
ITEM	CODIGO	DENOMINACION	TEXTO	CE9-20	CE9-40					NOTAS
12	U142814000	PORTAMANDOS CE9-20	CONTROL HOLDER CE9-20	1	-					
12	U172807000	PORTAMANDOS CE9-41	CONTROL HOLDER CE9-41	-	1					
	U022836000	ESCUDO FAGOR	FAGOR EMBLEM	1	1					
	Q221023000	CLIP SUJECIÓN RÁPIDA Ø5	RAPID CONNECT CLIP Ø5	2	2					
	Q152004000	TORNIL, APLASTADO M5x13 A304	FLAT HEADED BOLT M5x13 A304	2	2					
13	R062810000	PANEL LATERAL DERECHO	RIGHT SIDE PANEL	1	1					
	Q221343000	REMACHE EXAGONAL M6	HEXAGONAL RIVET M6	5	5					
	Q221342000	REMACHE EXAGONAL M5	HEXAGONAL RIVET M5	2	2					
	Q221342000	REMACHE EXAGONAL M5	HEXAGONAL RIVET M5	3	3					
14	U652820000	BASE INFERIOR CE9-20	LOWER BASE CE9-20	1	-					
14	U662850000	BASE INFERIOR CE9-40	LOWER BASE CE9-40	-	1					
	Q152004000	TORNIL, APLASTADO M5x13 A304	FLAT HEADED BOLT M5x13 A304	4	2					
	Q302022000	ARANDELA 16x6x1,2 A304	WASHER 16x6x1,2 A304	4	-					
	Q419007000	REMACHE TUBULAR C/V Ø3.2X6	TUBULAR RIVET C/V Ø3.2X6	-	8					
15	U672652000	ESCUADRA SOPOR. REGLETA CE	JPP. BRACKET TERMINAL STRIP	-	1					
15	U652650000	ESCUADRA SOPOR. REGLETA CE	JPP. BRACKET TERMINAL STRIP	1	-					
	Q419005000	REMACHE 4x8 ALMG3 / ALUMINIO	RIVET 4X8 ALMG3 / ALUMINIUM	3	3					
16	H012805000	ESCUADRA AMARRE PATA	LEG FASTENING BRACKET	2	2					
	Q162030000	TUERCA EXAGONAL M5	HEXAGONAL NUT M5	4	4					
	Q302022000	ARANDELA 16x6x1,2 A304	WASHER 16x6x1,2 A304	4	4					
17	U652651000	LISTON AMARRE ZOCALO 1/2M	SKIRTING FASTENING STRIP	1	-					
17	H022604000	LISTON AMARRE ZOCALO	SKIRTING FASTENING STRIP	-	1					
	Q419005000	REMACHE 4x8 ALMG3 / ALUMINIO	TUBULAR RIVET C/V Ø3.2X6	4	4					
	Q221342000	REMACHE EXAGONAL M5	HEXAGONAL RIVET M5	4	4					
18	R062805000	ZOCALO COMPLETO 1/2M	COMPLETE SKIRTING 1/2M	1	-					
18	H352817000	ZOCALO COMPLETO	COMPLETE SKIRTING	-	1					
	Q151336000	TORNILLO SOPORTE GUIAS	TORNILLO SOPORTE GUIAS	2	2					
	Q221343000	REMACHE EXAGONAL M6	HEXAGONAL RIVET M6	2	2					
	Q152004000	TORNIL, APLASTADO M5x13 A304	FLAT HEADED BOLT M5x13	2	2					
	Q302022000	ARANDELA 16x6x1,2 A304	WASHER 16x6x1,2 A304	2	2					

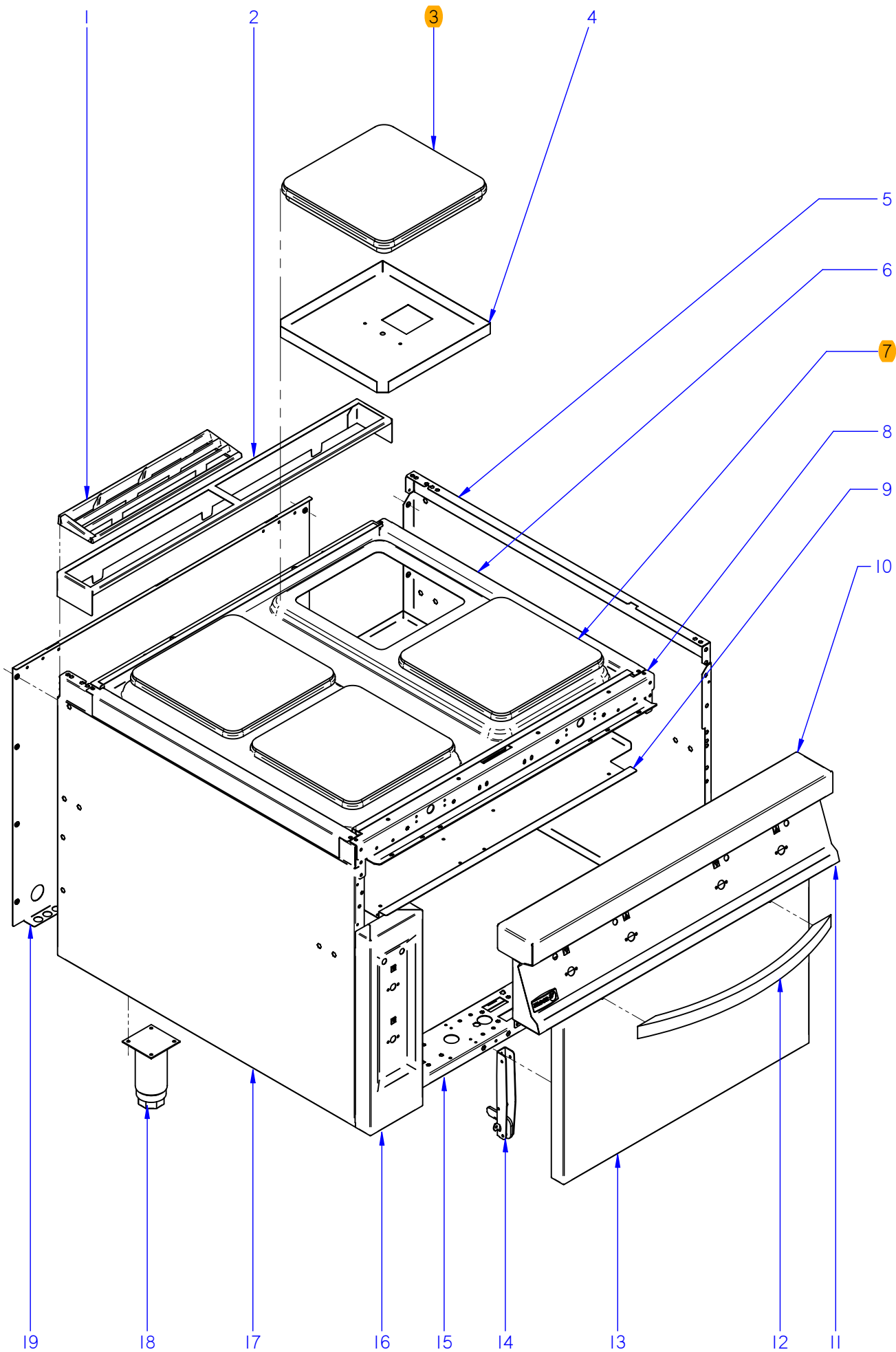

ITEM MARCADO EN COLOR = REPUESTO RECOMENDADO
 COLOURED ITEM = RECOMMENDED SPARE PART

N plano	Firma	Fecha	Aparato	MUEBLE	Lamina	Fagor Industrial S.Coop. FAGOR
C-2356	<i>[Signature]</i>	2009-06	COCINA CE9-41		2	Oñate

MOD.		COCINAS		ZONA	MUEBLE / UNIT				PLANO	C-2356
ITEM	CODIGO	DENOMINACION	TEXTO	CE9-41					NOTAS	
1	R205425000	EMBELLECEDOR ESMALTE	ENAMEL TRIM	2						
2	R205439000	SOPORTE EMBELLECEDOR 1 M	TRIM SUPPORT 1 M	1						
3	U673010000	PLACA 4000W 230V	PLATE 4000W 230V	1						
4	U675404000	CAZOLETA DE PLACAS	PLATE CASING	4						
	Q162050000	TUERCA EXAGONAL M8X1 INOX	HEXAGONAL NUT M8X1 INOX	4						
	Q262050000	ARANDELEA GROW. A8 A.304	WASHER GROW. A8 A.304	4						
	Q232050000	ARANDELA A8	WASHER A8	4						
5	U022842000	PANEL LATERAL DERECHO G9-00	RIGHT SIDE PANEL G9-00	1						
	Q221343000	REMACHE EXAGONAL M6	HEXAGONAL RIVET M6	11						
	Q221342000	REMACHE EXAGONAL M5	HEXAGONAL RIVET M5	11						
	Q152004000	TORNILLO APLASTADO M5x13 A304	FLAT HEADED BOLT M5x13	4						
6	U675450000	MESA 1M	BENCH 1 M	1						
	Q012032000	TORNILLO EXAGONAL M5x15	HEXAGONAL BOLT M5x15	4						
7	U673011000	PLACA 3000W 230V	PLATE 3000W 230V	3						
8	U022632000	ESCUA INTER AMAR ANTE 1 M	BRACKET INTER FASTE. FRONT	1						
	Q221342000	REMACHE EXAGONAL M5	HEXAGONAL RIVET M5	4						
	Q012032000	TORNILLO EXAGONAL M5x15	HEXAGONAL BOLT M5x15	4						
	Q152004000	TORNIL, APLASTADO M5x13 A304	FLAT HEADED BOLT M5x13 A304	6						
	Q302022000	ARANDELA 16x6x1,2 A304	WASHER 16x6x1.2 A304	6						
9	U022613000	BASE BANDEJAS 1 M	TRAY BASE 1 M	1						
	Q419005000	REMACHE 4x8 ALMG3 / ALUMINIO	RIVET 4X8 ALMG3 / ALUMINIUM	2						
10	S105402000	ANTERIOR MESA 1 M	BENCH FRONT 1 M	1						
	Q152004000	TORNIL, APLASTADO M5x13 A304	FLAT HEADED BOLT M5x13 A304	2						
	Q302022000	ARANDELA 16x6x1,2 A304	WASHER 16x6x1.2 A304	2						
11	U172810000	PORTAMANDOS COMPL. CE9-41	CONTROL HOLDER CE9-41	1						
	U022836000	ESCUDO FAGOR	FAGOR EMBLEM	1						
	Q221023000	CLIP SUJECIÓN RÁPIDA Ø5	RAPID CONNECT CLIP Ø5	2						
	Q152004000	TORNIL, APLASTADO M5x13 A304	FLAT HEADED BOLT M5x13	4						
12	U020504000	ASA DE HORNO COMPLETA G900	COMPL. OVEN HANDLE G900	1						
	Q012041000	TORNILLO EXAGONAL M6x10	HEXAGONAL BOLT M6x10	2						
	Q302022000	ARANDELA 16x6x1,2 A304	WASHER 16x6x1.2 A304	2						

N plano	Firma	Fecha	Aparato	HORNO	Lamina	Fagor Industrial S. Coop.
C-2357		2009-06	COCINA CE9-41		3	Onate

ITEM MARCADO EN COLOR = REPUESTO RECOMENDADO
 COLOURED ITEM = RECOMMENDED SPARE PART

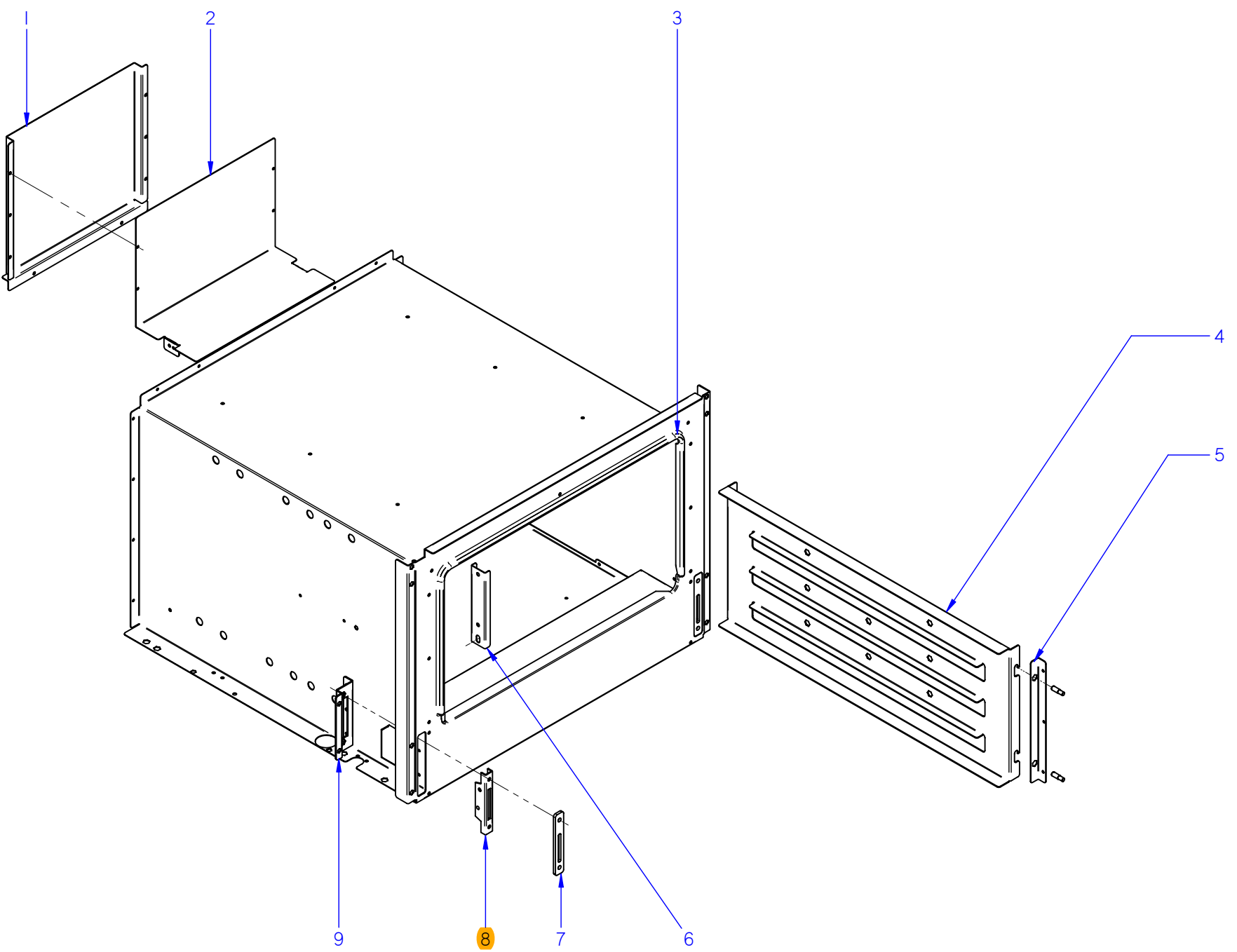

MOD.	COCINAS	ZONA	HORNO / OVEN	PLANO	C-2357
------	---------	------	--------------	-------	--------

ITEM	CODIGO	DENOMINACION	TEXTO	CE9-41							NOTAS
1	U675614000	POSTERIOR CHIMENEA CGE9-41	REAR FLUEPIPE CGE9-41	1							
	Q419005000	REMACHE 4x8 ALMG3 / ALUMINIO	RIVET 4X8 ALMG3 / ALUMINIUM	16							
2	U675615000	ANTERIOR DE CHIMENEA CGE9-41	FRONT FLUEPIPE CGE9-41	1							
3	U025623000	JUNTA PUERTA HORNO INOX	OVEN DOOR SEAL INOX.	1							
4	U915607000	GUIA LATERAL HORNO G700	OVEN SIDE GUIDE G700	2							
	Q151336000	TORNILLO SOPORTE GUIAS	GUIDE SUPPORT BOLT	4							
	Q302022000	ARANDELA 16X6X1.2 A.304	WASHER 16X6X1.2 A.304	4							
	Q221321000	REMACHE ROSCAD.NUTSERT.M6	THREADED RIVET .NUTSERT.M6	4							
5	U915616000	SUPLEMENTO AMARRE GUIA LAT.	SIDE GUIDE FAST. SUPPL.	2							
	Q412000000	REMACHE TUBULAR 4x8	TUBULAR RIVET 4x8	6							
6	U055644000	FIJACION BULBO	FASTENING BULB	1							
	Q412000000	REMACHE TUBULAR 4x8	TUBULAR RIVET 4x8	2							
7	U915619000	EMBELLECED GUIA BISAGRA	HINGE GUIDE TRIM	2							
	Q152045000	TORNILLO AMARRE M6X25	FASTENING BOLT M6X25	4							
8	U010512000	GUIA DE BISAGRA	HINGE GUIDE	2							
9	U915604000	AMARRE GUIA BISAGRA HORNO	OVEN HINGE GUIDE FASTENING	2							
	Q221342000	REMACHE EXAGONAL M5	HEXAGONAL RIVET M5	2							
	Q412000000	REMACHE TUBULAR 4x8	TUBULAR RIVET 4x8	6							
	Q222042000	REMACHE EXAGONAL ROSCA M6	HEXAGONAL RIVET THREAD M6	4							

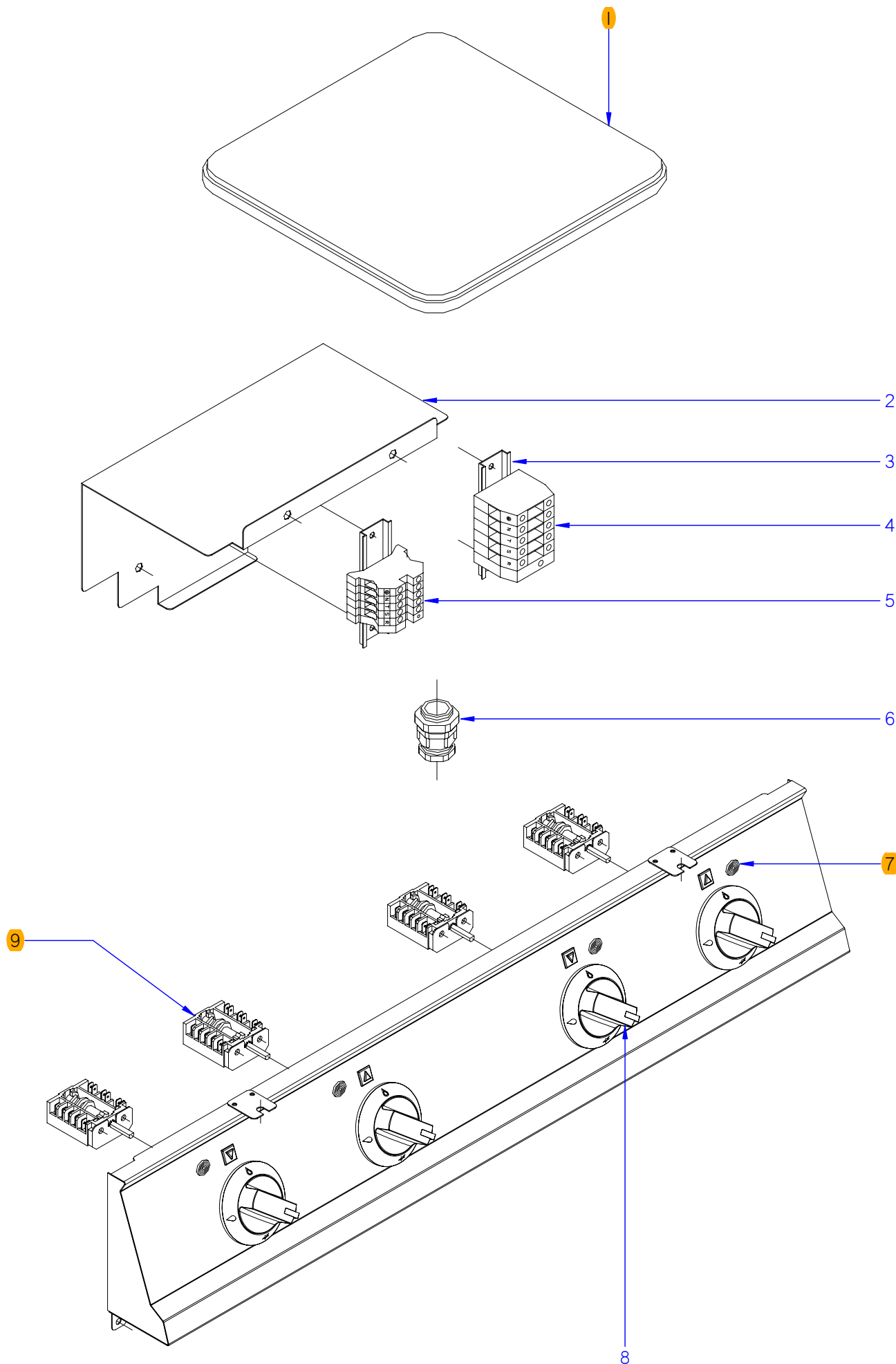

ITEM MARCADO EN COLOR = REPUESTO RECOMENDADO
 COLOURED ITEM = RECOMMENDED SPARE PART

N plano	Firma	Fecha	Aparato	PARTE FUNCIONAL	Lamina	Fagor Industrial S.Coop. FAGOR
C-1761	<i>[Signature]</i>	2007-01		COCINA CE9-40	5	Oñate

MOD.	COCINAS		ZONA	PARTE FUNCIONAL ELECTRICA				PLANO	C-1761
ITEM	CODIGO	DENOMINACION	TEXTO	CE9-20	CE9-40				NOTAS
1	U673011000	PLACA 3000W 230V	PLATE 3000W 230V	1	3				
1	U673012000	PLACA 3000W 400V SIN NEUTRO	PLATE 3000W 400V S/N	1	3				
1	U673010000	PLACA 4000W 230V	PLATE 4000W 230V	1	1				
1	U673013000	PLACA 4000W 400V SIN NEUTRO	PLATE 4000W 400V S/N	1	1				
2	U802602000	CHAPA PROTEC.CONMUTADORAS	SWITCH PROTECTION PLATE	1	2				
	Q152004000	TORNIL, APLASTADO M5x13 A304	FLAT HEADED BOLT M5x13	4	4				
	Q221341000	REMACHE EXAGONAL M 4	HEXAGONAL RIVET M4	1	1				
3	R663055000	GUIA CONTACTOR L-120	CONTACTOR GUIDE L-120	1	1				
	Q419005000	REMACHE 4x8 ALMG3 / ALUMINIO	RIVET 4X8 ALMG3 / ALUMINIUM	2	4				
4	R263003000	BORNA PASO 35 MM.	TAP TERMINAL 35 MM	-	3				
	R673010000	BORNA PASO AZUL 35 MM.	BLUE TAP TERMINAL 35 MM	-	1				
	Z103035000	BORNA TIERRA 35 MM.	TERMINAL TIER 35 MM.	-	1				
	Z683096000	TOPE FINAL WEW35 10590.0	END STOP WEW35 10590.0	-	1				
	Z683068000	SEÑALIZ.DEK-6 WEIDMULLER	SIGNAL.DEK-6 WEIDMULLER	-	1				
5	P453025000	BORNES 10 WDU-10203.0	TERMINAL 10 WDU-10203.0	3	-				
	Z263302000	BORNA PASO AZUL	BLUE TAP TERMINAL	1	-				
	P453026000	BORNA TIERRA 10 WPE-10103.3	TERMINAL TIER 10 WPE-10103.3	1	-				
	Z263303000	TOPE FINAL	END STOP	1	-				
	Z683068000	SEÑALIZ.DEK-6 WEIDMULLER	SIGNAL.DEK-6 WEIDMULLER	1	-				
6	R023013000	PRENSA ESTOPAS	STUFFING BOX	1	1				
	R023025000	CONTRATUERCA (GAES)	COUNTERNUT (GAES)	1	1				
	R023026000	JUNTA DE GOMA (GAES)	RUBBER SEAL (GAES)	1	1				
7	R693056000	PILOTO AMBAR	PILOTO AMBAR	2	4				
8	U173007000	BOTON DE MANDO Ø 6	CONTROL Ø6	2	4				
9	U673007000	CONMUTADOR EGO	SWITCH EGO	2	4				
	Q151320000	TORNILLO ALOMADO M4x6 H.ZINC.	CURVED SCREW M4X6 H. ZINC	4	8				

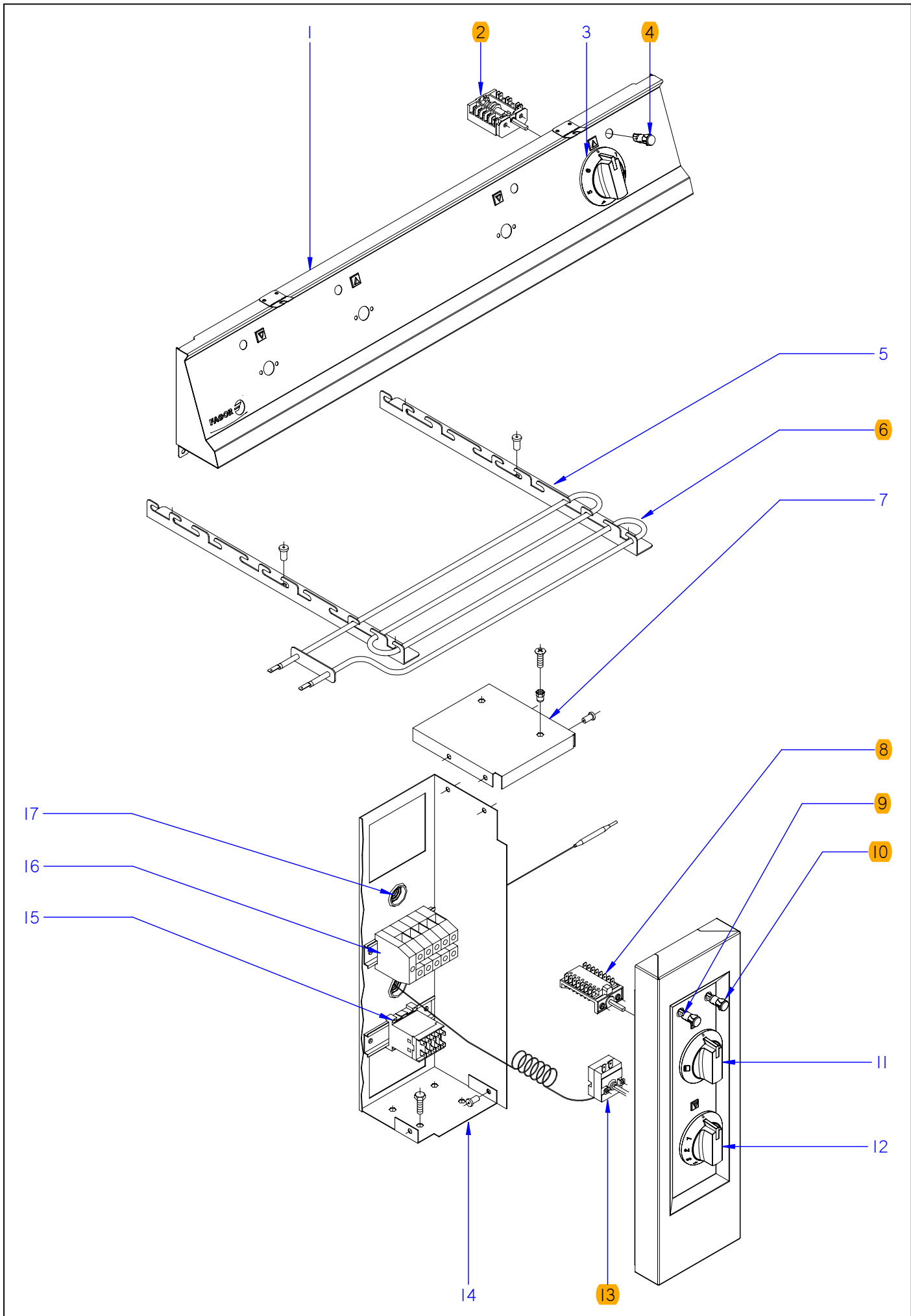

ITEM MARCADO EN COLOR = REPUESTO RECOMENDADO
 COLOURED ITEM = RECOMMENDED SPARE PART

N plano	Firma	Fecha	Aparato	CONJUNTO FUNCIONAL ELECTRICO	Lamina	Fagor Industrial S.Coop. FAGOR
C-2358	<i>[Signature]</i>	2009-06	COCINA CE9-41		5	Oñate

MOD.		COCINAS		ZONA	CONJUNTO FUNCIONAL ELECTRICO				PLANO	C-2358
ITEM	CODIGO	DENOMINACION	TEXTO	CE9-41					NOTAS	
1	U172810000	PORTAMANDOS COMPL. CE9-41	CONTROL HOLDER CE9-41	1						
2	U673007000	CONMUTADOR EGO	SWITCH EGO	4						
	Q151320000	TORNILLO ALOMADO M4x6 H.ZINC.	CURVED SCREW M4X6 H. ZINC	8						
3	U173007000	MANDO MONTADO CE Ø6	CONTROL CE Ø6	4						
4	R693056000	PILOTO AMBAR	AMBER PILOT	4						
5	U805613000	ESCUADRA SOPOR. RESISTENCIAS	SUPP. BRACKET RESISTORS	4						
	Q419005000	REMACHE 4x8 ALMG3 / ALUMINIO	RIVET 4X8 ALMG3 / ALUMINIUM	12						
6	U803004000	RESISTENCIA 1000W/230V	RESISTOR 1000W -230V	6						
7	U673051000	TAPA DE CUADRO ELECTRICO	ELECTRIC PANEL COVER	1						
	Q419005000	REMACHE 4x8 ALMG3 / ALUMINIO	RIVET 4X8 ALMG3 / ALUMINIUM	4						
	Q419005000	REMACHE 4x8 ALMG3 / ALUMINIO	RIVET 4X8 ALMG3 / ALUMINIUM	2						
	Q221342000	REMACHE EXAGONAL M5	HEXAGONAL RIVET M5	2						
	Q012032000	TORNILLO EXAGONAL M5x15 A304	HEXAGONAL BOLT M5x15	2						
	Q012032000	TORNILLO EXAGONAL M5x15 A304	HEXAGONAL BOLT M5x15	2						
8	U673006000	CONMUTADOR	SWITCH	1						
	Q151320000	TORNILLO ALOMADO M4x6 H.ZINC.	CURVED SCREW M4X6 H. ZINC	2						
9	R693055000	PILOTO VERDE	GREEN PILOT	1						
10	R693056000	PILOTO AMBAR	AMBER PILOT	1						
11	U173006000	MANDO MONTADO CE Ø6	CONTROL CE Ø6	1						
12	U173005000	MANDO CE Ø6 TERMOSTATO	CONTROL Ø6 THERMOSTAT	1						
13	X153000000	TERMOSTATO 50-310° C	THERMOSTAT 50-310 C	1						
	Q151320000	TORNILLO ALOMADO M4x6 H.ZINC.	CURVED SCREW M4X6 H. ZINC	2						
14	U673050000	CUADRO ELECTRICO	ELECTRICAL PANEL	1						
15	Z213007000	CONTACTOR 3TF2010-3AL2	CONTACTOR 3TF2010-3AL2	1						
	R663055000	GUIA CONTACTOR L-120	CONTACTOR GUIDE L-120	1						
	Q419005000	REMACHE 4x8 ALMG3 / ALUMINIO	RIVET 4X8 ALMG3 / ALUMINIUM	4						
16	R263003000	BORNA PASO 35 MM.	TAP TERMINAL 35 MM	3						
	R673010000	BORNA PASO AZUL 35 MM.	BLUE TAP TERMINAL 35 MM	1						
	Z103035000	BORNA TIERRA 35 MM.	TERMINAL TIER 35 MM.	1						
	Z683069000	TOPE FINAL WEW35 10590.0	END STOP WEW35 10590.0	1						
17	X723014000	PASAMUROS AMETRO 30	BUSHING AMETRO 30	2						

MOD.		COCINAS		ZONA	VARIOS / MISCELLANEOUS			PLANO		
ITEM	CODIGO	DENOMINACION	TEXTO	CE9-20	CE9-40	CE9-41				NOTAS
	U176501000	FOLLETO DE INSTRUCCIONES CE	INSTRUCTION LEAFLET CE	1	1	1				
	U653001000	ESQUEMA TEORICO ADHESIVO	THEOR. DIAGRAM LABEL	1	_	_				PLANO HC-72730
	U663000000	ESQUEMA TEORICO ADHESIVO	THEOR. DIAGRAM LABEL	_	1	_				PLANO HC-72734
	U673001000	ESQUEMA TEORICO ADHESIVO	THEOR. DIAGRAM LABEL	_	_	1				PLANO HC-71190
	U653003000	CABLEADO PORTAMANDOS MESA	BENCH CTRL HOLDER WIRING	1	_	_				
	U673052000	CABLEADO PORTAMANDOS MESA	BENCH CTRL HOLDER WIRING	_	1	1				
	U673014000	CABLEADO A PLACAS	WIRING TO PLATES	2	4	4				
	U673008000	CABLEADO HORNO	OVEN WIRING	_	_	1				

MOD.		COCINAS		ZONA	PIEZAS ESPECIFICAS PARA LOS DISTINTOS VOLTAJES			PLANO	
ITEM	CODIGO	DENOMINACION	TEXTO	CE9-20	CE9-40	CE9-41			NOTAS
VERSION: 380 / 415 V									
1	U673011000	PLACA 3000W 230V	PLATE 3000W 230V	1	3	3			
1	U673010000	PLACA 4000W 230V	PLATE 4000W 230V	1	1	1			
VERSION: 440 V 3									
1	U673012000	PLACA 3000W 400V	PLATE 3000W 400V	1	3	3			
1	U673013000	PLACA 4000W 400V	PLATE 4000W 400V	1	1	1			
S/N	U803072000	RESISTENCIA 150K, 1/4W	RESISTOR 150K 1/4W	2	4	6			PARA PILOTOS
S/N	U803073000	RESISTENCIA 8K2, 6W	RESISTOR 8K2, 6W	-	-	1			PARA CONTACTOR HORNO

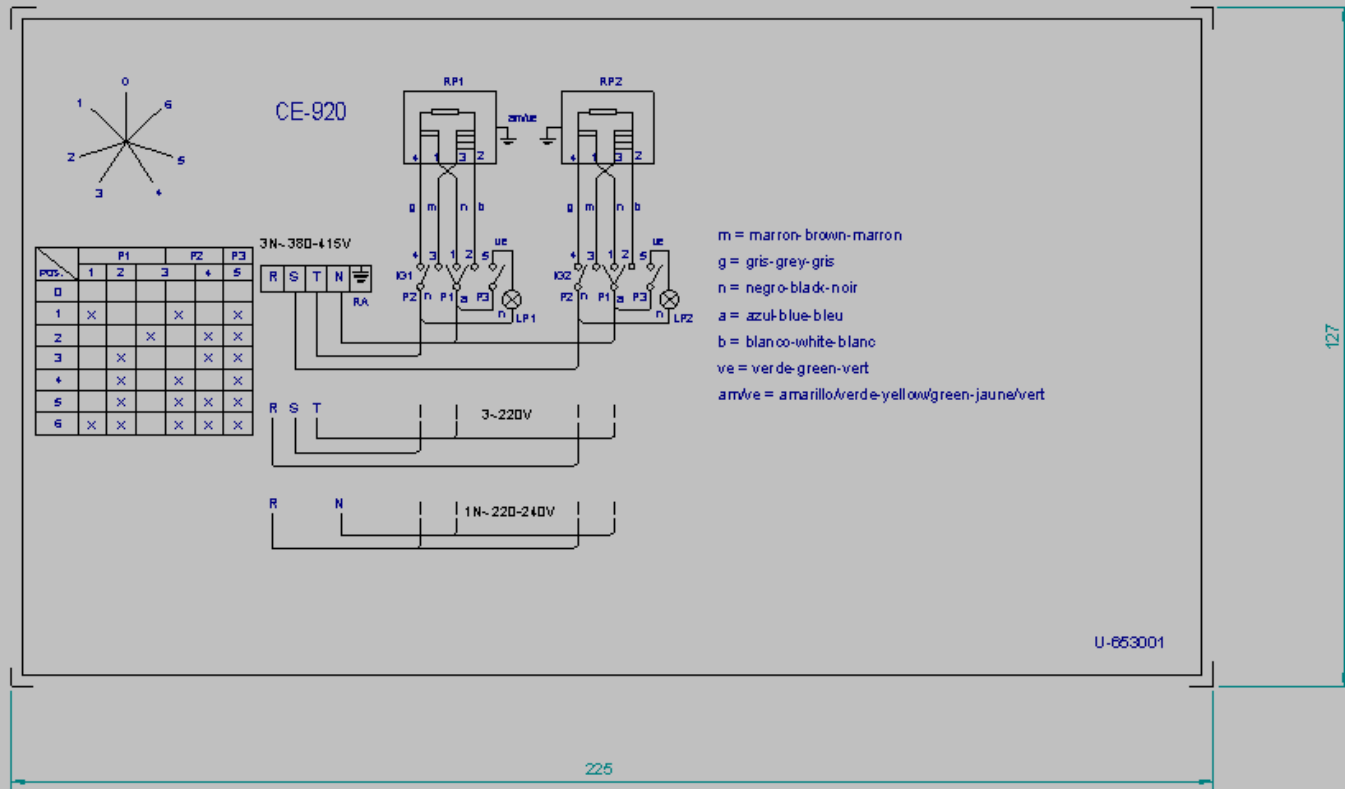

NOTA

- Las inscripciones resistirán sin modificación apreciable el frotamiento durante 15 seg. de un algodón impregnado en gasolina.

RA: Regleta de Alimentación

IG1, IG2: Conmutadores de placas eléctricas

RP1, RP2: Placas eléctricas

LP1, LP2: Lámpara Calentamiento de Placas

Plastico blanco alto brillo

Esquema teorico		U-653001	
N°	Pieza	Carit.	Material
N°	Modificaci.	Propuesta de	
		Fecha	
		Toleancias generales	
		<3±	50-100±
		5-25±	>100±
		25-50±	∞±
Dibujado		Firma	Fecha
Proyectado		P. Izquierdo	21-4-97
Comprobado		FAGOR	
Ejecuto		Fagor Industrial, Koop. Ek., Miragüta	
1/1		COCINAS ELECTRICAS	
Plano numero		HC-72730	
Sustituye al N°		HB-70038	
Sustituido por			

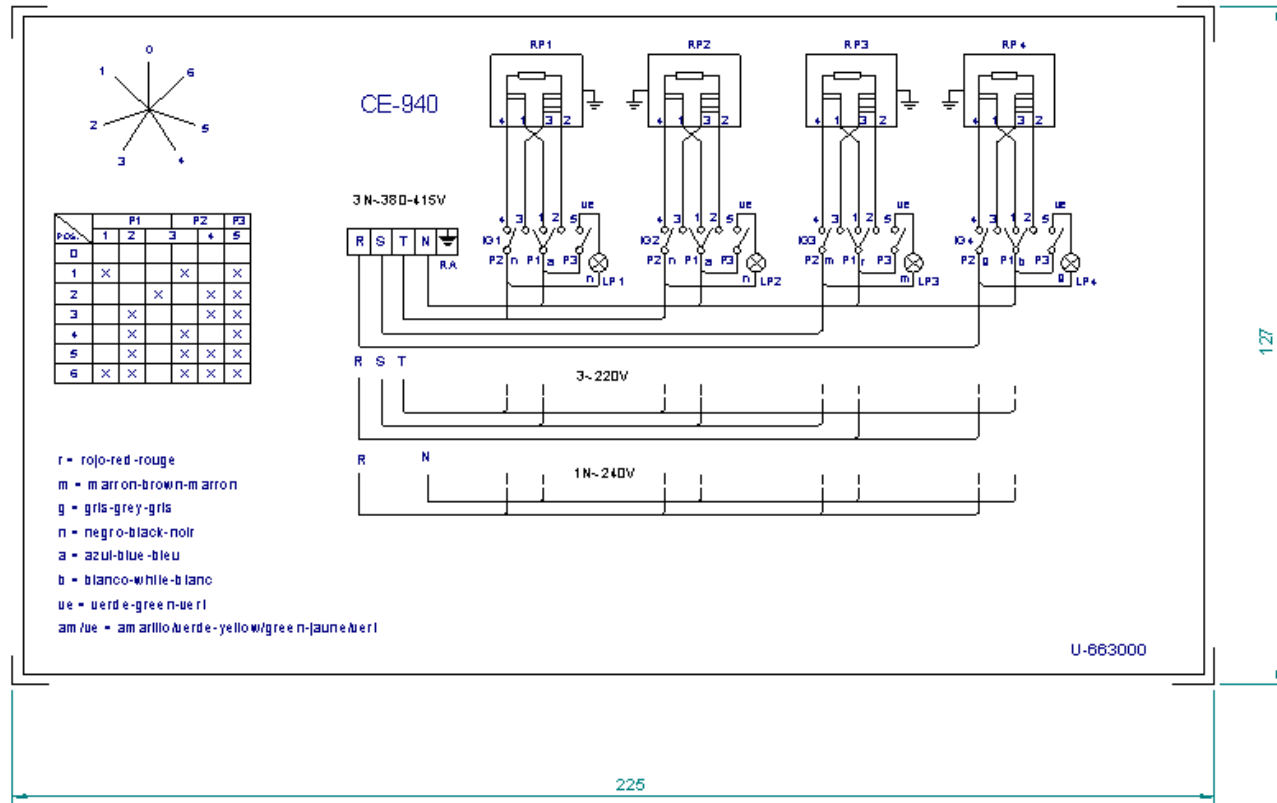

NOTA

- Las inscripciones resistirán sin modificación apreciable el frotamiento durante 15 seg. de un algodón impregnado en gasolina.

- RA: Regleta de Alimentación
- IG1, IG2, IG3, IG4: Conmutadores de placas eléctricas
- RP1, RP2, RP3, RP4: Placas eléctricas
- LP1, LP2, LP3, LP4: Lámpara Calentamiento de Placas

Plastico blanco alto brillo

Esquema teorico		U-663000	
Nº	Pieza	Cant.	Material
Nº	Modificacio	Propiedad de	
		Fecha	Tolerancias generales
			<5±
			5-25±
			25-50±
			50-100±
			>100±
			∞±
Dibujado		Firma	Fecha
Proyectado		P. Izquierdo	22-4-97
Comprobado		FAGOR	
Escala		Fagor Industrial, Koop. Ek., Magaña	
1/1		COCINAS ELECTRICAS	
Plano número		HC-72734	
Sistema al N°		HB-70039	
Sistema por			

CE 941

CE 741

CE 641

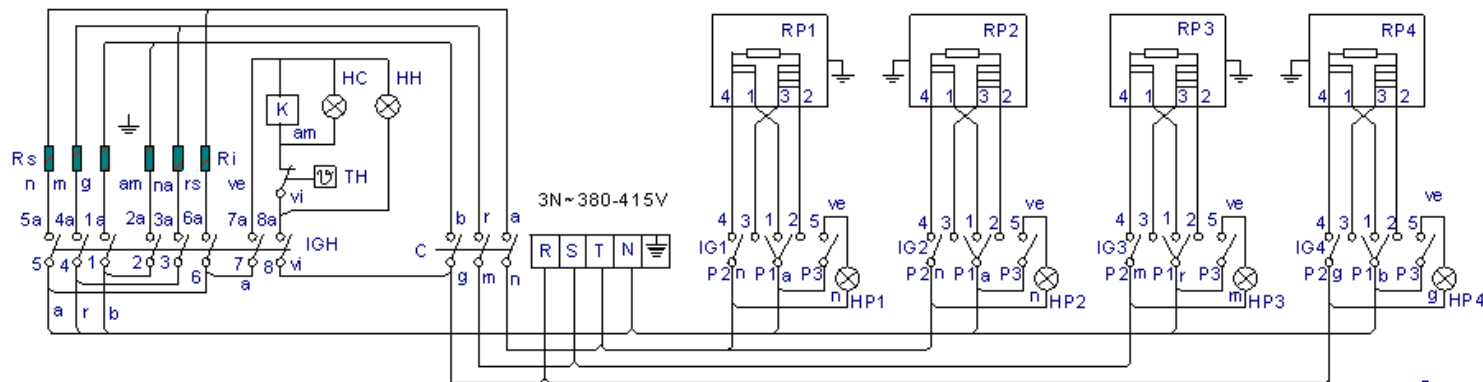

- r = rojo-red-rouge
- m = marron-brown-m arron
- g = gris-grey-gris
- n = negro-black-noir
- a = azul-blue-bleu
- b = blanco-white-blanc
- vi = violeta-violette-violet
- am = amarillo-yellow-jaune
- na = naranja-orange-orange
- rs = rosa-rose-pink
- ve = verde-green-vert
- am /ve = amarillo/verde-yellow w/green-jaune /vert

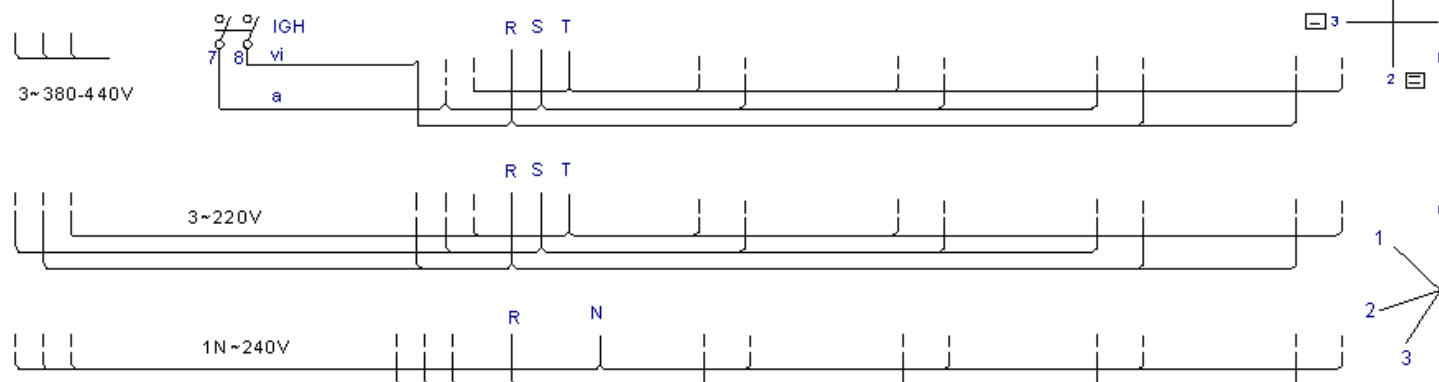

	1_2	3_4	5_6	7	8
	1a	2a	3a	4a	5a
0					
1	X		X	X	X
2	X	X	X	X	X
3	X	X		X	X

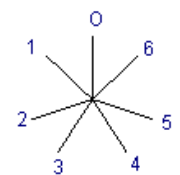

IG		P1	P2	P3
POS.	1	2	3	4
0				
1	X		X	X
2		X		X
3	X		X	X
4	X	X		X
5	X	X	X	X
6	X	X	X	X

- HPx: Lampara Calentamiento Placas / Heating lamp (electrical plates)
- HC : Lampara Calentamiento Horno / Heating lamp (oven)
- IGx: Conmutadores de placas electricas / Main switch (electrical plates)
- Ri : Resistencia Horno Inferior / Lower resistance (oven)
- TFR: Transformador / Transformer
- IGH : Conmutador General Horno / Oven main switch
- Rs: Resistencia Horno Superior / Top resistance (oven)
- K: Contactor / Contactor
- HH : Lam para Horno Encendido / Main lamp (oven)
- RPx: Placas electricas / Electrical plates

U673001000

Esquema teorico adhesivo		U-673001	
Nº	Pieza	Cart.	Material
Nº	Modificacio	Propuesta de	
		Fecha	
		Tole rancias generales	
		<3±	
		5-25±	
		25-50±	
		50-100±	
		>100±	
		X±	
Dibujado		Firma	Fecha
Proye ctado		Imp rtado	31.05.05
Com probado		FAGOR	
Escrib		Fagor Industrial, Koop. Ek., Miragiba	
1/1		COCINAS	
Falso hueco caldero eral es hermetico calentamiento		Mecanizado superior	
		Plano numero HC-71190	
		Sustituye al N°	
		Sustituido por	