

**Cocinas Eléctricas  
Fourneaux Électriques  
Electric Ranges  
Cucine Elettriche  
Fogões Elétricos  
Elektro-Herde**

**GAMA SANCK**

**Modelos:**

**CE6-20**

**CE6-40**

**CE6-41**

*Junio 2009 June*

*Revisado Abril 2010 April*



**Fagor Industrial**

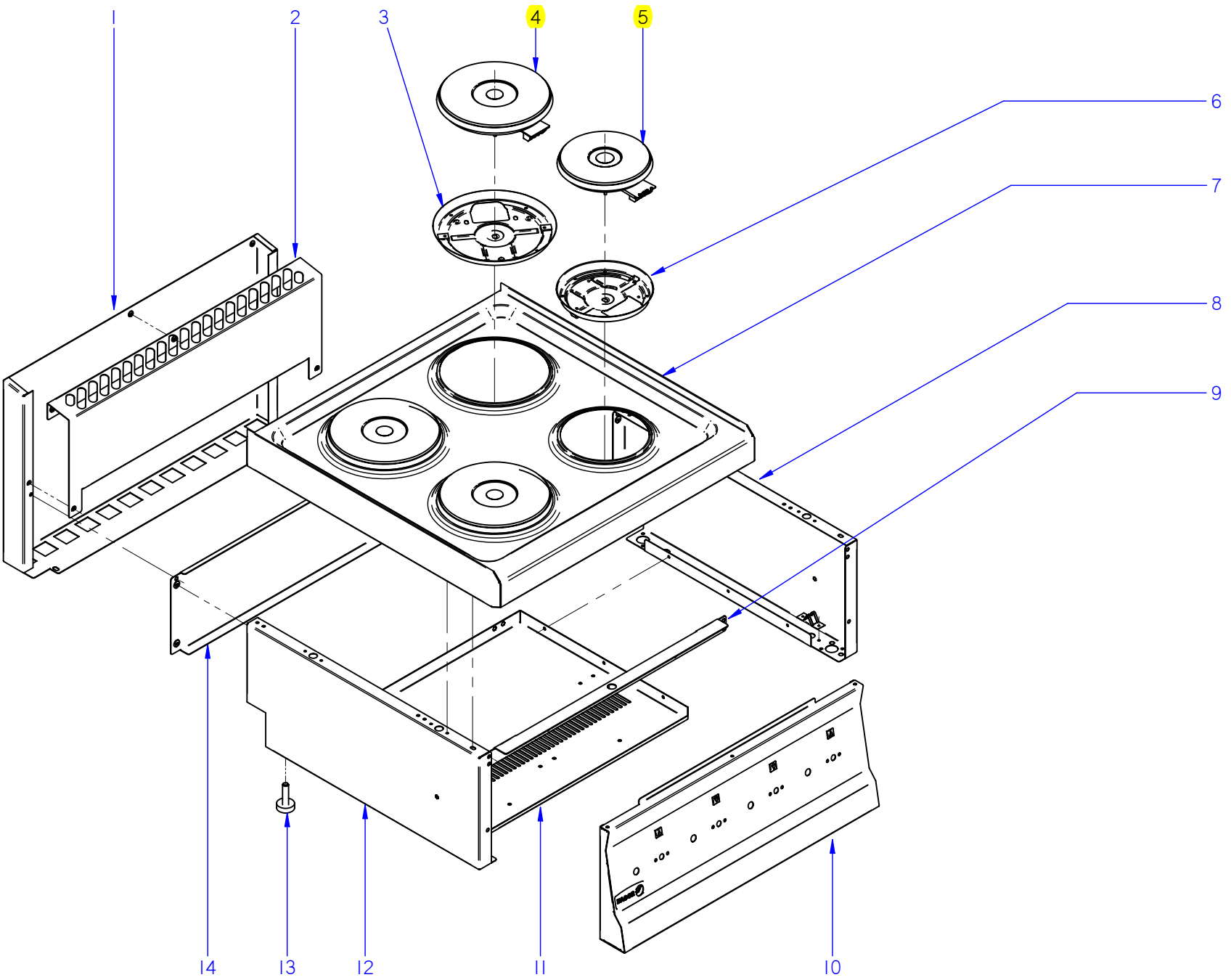

ITEM MARCADO EN COLOR = REPUESTO RECOMENDADO  
 COLOURED ITEM = RECOMMENDED SPARE PART

N plano	Firma	Fecha	Aparato	MUEBLE	Lamina	Fagor Industrial S. Coop.
C-2376	<i>(Firma)</i>	2009-06	COCINAS CE6-20 / CE6-40		1	Ondate <b>FAGOR</b>

MOD.		COCINAS /RANGES		ZONA	MUEBLE / UNIT				PLANO	C-2376
ITEM	CODIGO	DENOMINACION	TEXTO	CE6-20	CE6-40				NOTAS	
1	J142809000	PROTECCION CHIMENEA POS. 400	PROTECTION CHIMEMEY POS.	1	1					
1	J142812000	PROTECCION CHIMENEA POS. 600	PROTECTION CHIMEMEY POS.	1	1					
	Q419005000	REMACHE 4X8 ALMG3 / ALUMINIO	RIVET 4X8 ALMG3 / ALUMINIUM	2	2					
2	J142810000	PROTECCION CHIMENEA ANT. 400	PROTECTION CHIMENEY ANT	1	1				ELIMINADA 01.04.2010	
2	J142829000	PROTECCION CHIMENEA FREID.	PROTECTION CHIMENEY	1	1				INTRODUC. 01.04.2010	
2	J142813000	PROTECCION CHIMENEA ANT. 600	PROTECTION CHIMENEY ANT	1	1				ELIMINADA 01.04.2010	
2	J142830000	PROTECCION CHIMENEA ANT. 600	PROTECTION CHIMENEY ANT	1	1				INTRODUC. 01.04.2010	
	Q012031000	TORNILLO EXAGONAL M5x10 A304	HEXAGONAL BOLT M5x10 A304	4	4					
	Q302022000	ARANDELA 16x6x1,2 A304	WASHER 16x6x1.2 A304	4	4					
	Q221342000	REMACHE EXAGONAL M5	HEXAGONAL RIVET M5	3	3					
3	J032601000	CAZOLETA 2000W	CASING 2000W	2	3					
4	J033001000	PLACA PUNTO ROJO 2000W-230V	RED POINT PLATE 2000W-230V	2	3					
5	U803002000	PLACA PUNTO ROJO 1500W-230V	RED POINT PLATE 500W-230V	1	1					
6	U793031000	CAZOLETA 1500W.ULGOR	CASING1500W.ULGOR	1	1					
	Z608410000	CASQUILLO AMARRE TECLADO	KEYBOARD ANCHORAGE BUSH	2	4					
	Q162040000	TUERCA EXAGONAL M6	HEXAGONAL NUT M6	2	4					
	Q302022000	ARANDELA 16X6X1.2 A.304	WASHER 16X6X1.2 A.304	2	4					
7	J035409000	ENCIMERA CE6-20 COMPL.	TOP CE6-20 COMPL.	1	1					
7	J035410000	ENCIMERA CE6-40 COMPL.	TOP CE6-40 COMPL.	1	1					
	Q221342000	REMACHE EXAGONAL M5	HEXAGONAL RIVET M5	4	4					
	X012612000	PITON CIERRE	LOCK SPIKE	2	4				ELIMINADA 01.04.2010	
	Z442919000	PITON CIERRE	LOCK SPIKE	2	4				INTRODUC. 01.04.2010	
	Q221342000	REMACHE EXAGONAL M5	HEXAGONAL RIVET M5	2	2					
8	J002802000	PANEL LATERAL DERECHO	RIGHT SIDE PANEL	1	1				ELIMINADA 01.04.2010	
8	J002834000	PANEL LATERAL DERECHO	RIGHT SIDE PANEL	1	1				INTRODUC. 01.04.2010	
	Q221342000	REMACHE EXAGONAL M5	HEXAGONAL RIVET M5	1	1					
	Q419007000	REMACHE TUBULAR C/V D3.2X6	TUBULAR RIVET C/V D3.2X6	8	8					
	X010503000	CIERRE MUELLE	LOCK SPRING	4	4				ELIMINADA 01.04.2010	
	Z442918000	CLIP CIERRE	LOCK SPRING	4	4				INTRODUC. 01.04.2010	

MOD.		COCINAS /RANGES		ZONA	MUEBLE / UNIT					PLANO	C-2376
ITEM	CODIGO	DENOMINACION	TEXTO	CE6-20	CE6-40						NOTAS
9	J002610000	GUÍA PANEL PORTAMANDOS	GUIDE PANEL OF CONTROLS	1	—						
9	J002612000	GUÍA PANEL PORTAMANDOS 600	GUIDE PANEL OF CONTROLS	—	1						
	Q221342000	REMACHE EXAGONAL M5	HEXAGONAL RIVET M5	4	4						
	Q012031000	TORNILLO EXAGONAL M5x10 A304	HEXAGONAL BOLT M5x10 A304	4	4						
10	J242802000	PORTAMANDOS COMPL. CE6-20	CONTROL HOLDER CE6-20	1	—						
10	J242804000	PORTAMANDOS COMPL. CE6-40	CONTROL HOLDER CE6-40	—	1						
	U022836000	ESCUDO FAGOR	FAGOR EMBLEM	1	1						
	Q221023000	CLIP SUJECIÓN RÁPIDA Ø5	RAPID CONNECT CLIP Ø5	2	2						
	Q419005000	REMACHE 4x8 ALMG3 / ALUMINIO	RIVET 4X8 ALMG3 / ALUMINIUM	6	6						
	Q012031000	TORNILLO EXAGONAL M5x10 A304	HEXAGONAL BOLT M5x10 A304	2	2						
	Q302022000	ARANDELA 16x6x1,2 A304	WASHER 16x6x1.2 A304	2	2						
11	J002604000	BASE INFERIOR 400	LOWER BASE 400	1	—						
11	J002607000	BASE INFERIOR 600	LOWER BASE 600	—	1						
	Q419005000	REMACHE 4x8 ALMG3 / ALUMINIO	RIVET 4X8 ALMG3 / ALUMINIUM	6	6						
12	J002801000	PANEL LATERAL IZQUIERDO	LEFT SIDE PANEL	1	1						ELIMINADA 01.04.2010
12	J002833000	PANEL LATERAL IZQUIERDO	LEFT SIDE PANEL	1	1						INTRODUC. 01.04.2010
	Q221342000	REMACHE EXAGONAL M5	HEXAGONAL RIVET M5	1	1						
	Q419007000	REMACHE TUBULAR C/V D3.2X6	TUBULAR RIVET C/V D3.2X6	8	8						
	X010503000	CIERRE MUELLE	LOCK SPRING	4	4						ELIMINADA 01.04.2010
	Z442918000	CLIP CIERRE	LOCK SPRING	4	4						INTRODUC. 01.04.2010
13	Z200107000	PATA REGULABLE	ADJUSTABLE LEG	4	4						
14	J002803000	PANEL POSTERIOR 400	REAR PANEL 400	1	—						
14	J002804000	PANEL POSTERIOR 600	REAR PANEL 600	—	1						
	Q419005000	REMACHE 4x8 ALMG3 / ALUMINIO	RIVET 4X8 ALMG3 / ALUMINIUM	4	4						

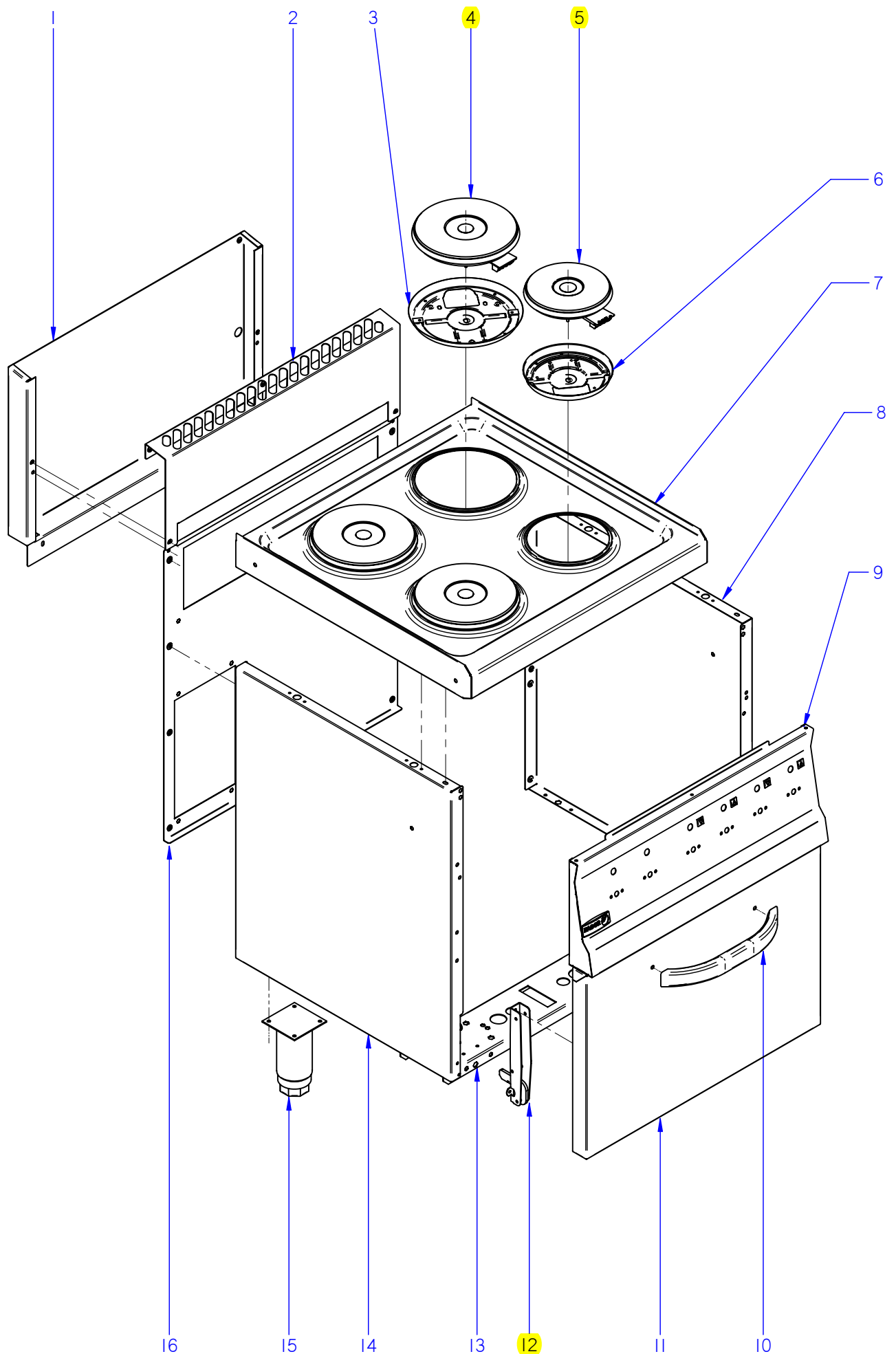

ITEM MARCADO EN COLOR = REPUESTO RECOMENDADO  
 COLOURED ITEM = RECOMMENDED SPARE PART

N plano	Firma	Fecha	Aparato	MUEBLE	Lamina	Fagor Industrial S.Coop. <b>FAGOR</b>
C-2377	<i>(Signature)</i>	2009-06	COCINA CE6-41		2	Oñate

MOD.		COCINAS /RANGES		ZONA	MUEBLE / UNIT						PLANO	C-2377
ITEM	CODIGO	DENOMINACION	TEXTO	CE6-41							NOTAS	
1	J042801000	PROTECCION CHIMENEA POST.	PROTECTION CHIMEMEY POS.	1								
	Q419005000	REMACHE 4X8 ALMG3 / ALUMINIO	RIVET 4X8 ALMG3 / ALUMINIUM	2								
2	J142813000	PROTECCION CHIMENEA ANT. 600	PROTECTION CHIMENEY ANT	1							ELIMINADA 01.04.2010	
2	J142830000	PROTECCION CHIMENEA ANT. 600	PROTECTION CHIMENEY ANT	1							INTRODUC. 01.04.2010	
	Q012031000	TORNILLO EXAGONAL M5x10 A304	HEXAGONAL BOLT M5x10 A304	4								
	Q302022000	ARANDELA 16x6x1,2 A304	WASHER 16x6x1.2 A304	4								
3	J032601000	CAZOLETA 2000W	CASING 2000W	3								
4	J033001000	PLACA PUNTO ROJO 2000W-230V	RED POINT PLATE 2000W-230V	3								
5	U803002000	PLACA PUNTO ROJO 1500W-230V	RED POINT PLATE 500W-230V	1								
6	U793031000	CAZOLETA 1500W.ULGOR	CASING1500W.ULGOR	1								
	Z608410000	CASQUILLO AMARRE TECLADO	KEYBOARD ANCHORAGE BUSHI	4								
	Q162040000	TUERCA EXAGONAL M6	HEXAGONAL NUT M6	4								
	Q302022000	ARANDELA 16X6X1.2 A.304	WASHER 16X6X1.2 A.304	4								
7	J035410000	ENCIMERA CE6-40 COMPL.	TOP CE6-40 COMPL.	1								
	Q221342000	REMACHE EXAGONAL M5	HEXAGONAL RIVET M5	4								
	X012612000	PITON CIERRE	LOCK SPIKE	2							ELIMINADA 01.04.2010	
	Z442919000	PITON CIERRE	LOCK SPIKE	2							INTRODUC. 01.04.2010	
	Q221342000	REMACHE EXAGONAL M5	HEXAGONAL RIVET M5	2								
8	J022802000	PANEL LATERAL DCHO CG6-41	LATERAL RIGHT RANGE CG6-41	1							ELIMINADA 01.04.2010	
8	J022816000	PANEL LATERAL DCHO CG6-41	LATERAL RIGHT RANGE CG6-41	1							INTRODUC. 01.04.2010	
	Q419005000	REMACHE 4X8 ALMG3 / ALUMINIO	RIVET 4X8 ALMG3 / ALUMINIUM	4								
	X010503000	CIERRE MUELLE	LOCK SPRING	2							ELIMINADA 01.04.2010	
	Z442918000	CLIP CIERRE	LOCK SPRING	2							INTRODUC. 01.04.2010	
	Q419007000	REMACHE TUBULAR C/V D3.2X6	TUBULAR RIVET C/V D3.2X6	4								
	Q221342000	REMACHE EXAGONAL M5	HEXAGONAL RIVET M5	1								
9	J042803000	PORTAMANDOS COMPL. CE6-41	CONTROL HOLDER CE6-41	1								
	U022836000	ESCUDO FAGOR	FAGOR EMBLEM	1								
	Q221023000	CLIP SUJECIÓN RÁPIDA Ø5	RAPID CONNECT CLIP Ø5	2								
	Q419005000	REMACHE 4x8 ALMG3 / ALUMINIO	RIVET 4X8 ALMG3 / ALUMINIUM	6								
	Q012031000	TORNILLO EXAGONAL M5x10 A304	HEXAGONAL BOLT M5x10 A304	2								
	Q302022000	ARANDELA 16x6x1,2 A304	WASHER 16x6x1.2 A304	2								

MOD.		COCINAS /RANGES		ZONA	MUEBLE / UNIT					PLANO	C-2377
ITEM	CODIGO	DENOMINACION	TEXTO	CE6-41							NOTAS
10	Z400542000	ASA LVS.	HANDLE LVS.	1							
	Q012041000	TORNILLO EXAGONAL M6x10	HEXAGONAL BOLT M6x10	2							
	Q302022000	ARANDELA 16x6x1,2 A304	WASHER 16x6x1.2 A304	2							
11	J040501000	PUERTA DE HORNO	OVEN DOOR	1							
12	U020528000	BISAGRA CIERRE HORNO	OVEN LOCK HINGE	2							
	Q152022000	TORNILLO M6x8	BOLT M6x8	6							
13	J002613000	LISTON SOPORTE PATAS	TIEDOWN SUPPORTS MB6-40	2							
	Q221343000	REMACHE EXAGONAL M6	HEXAGONAL RIVET M6	4							
	Q221342000	REMACHE EXAGONAL M5	HEXAGONAL RIVET M5	1							
14	J022801000	PANEL LATERAL IZDO. CG6-41	LATERAL LEFT RANGE CG6-41	1							ELIMINADA 01.04.2010
14	J022815000	PANEL LATERAL IZDO. CG6-41	LATERAL LEFT RANGE CG6-41	1							INTRODUC. 01.04.2010
	Q419005000	REMACHE 4X8 ALMG3 / ALUMINIO	RIVET 4X8 ALMG3 / ALUMINIUM	4							
	X010503000	CIERRE MUELLE	LOCK SPRING	2							ELIMINADA 01.04.2010
	Z442918000	CLIP CIERRE	LOCK SPRING	2							INTRODUC. 01.04.2010
	Q419007000	REMACHE TUBULAR C/V D3.2X6	TUBULAR RIVET C/V D3.2X6	4							
	Q221342000	REMACHE EXAGONAL M5	HEXAGONAL RIVET M5	1							
15	X260151000	PATA REGULABLE	ADJUSTABLE LEG	4							
	Q411304000	REMACHE AVIBULB Ø 4,8	AVIBULB RIVET Ø 4.8	16							
16	J022805000	PANEL POSTERIOR CE6-41	REAR PANEL CE6-41	1							
	Q419005000	REMACHE 4X8 ALMG3 / ALUMINIO	RIVET 4X8 ALMG3 / ALUMINIUM	8							
	Q221342000	REMACHE EXAGONAL M5	HEXAGONAL RIVET M5	2							

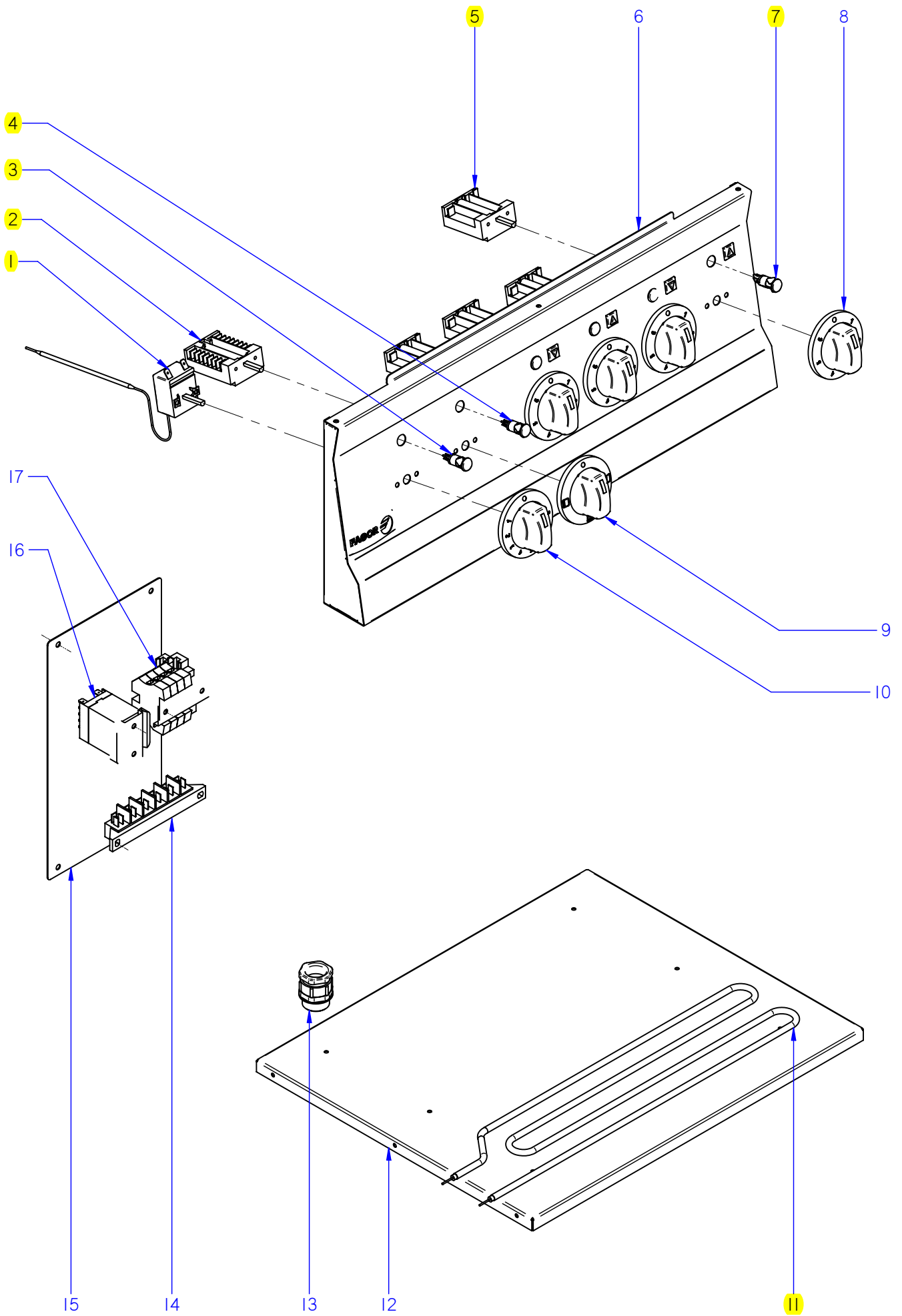

ITEM MARCADO EN COLOR = REPUESTO RECOMENDADO  
 COLOURED ITEM = RECOMMENDED SPARE PART

N plano	Firma	Fecha	Aparato	CONJUNTO FUNCIONAL	Lamina	Fagor Industrial S.Coop. <b>FAGOR</b>
C-2378	<i>(Signature)</i>	2009-06	COCINAS	CE6-20 / 40 / 41	3	Oñate



MOD.		COCINAS /RANGES		ZONA	CONJUNTO FUNCIONAL / FUNCTIONAL UNIT			PLANO	C-2378	
ITEM	CODIGO	DENOMINACION	TEXTO	CE6-20	CE6-40	CE6-41				NOTAS
1	X153000000	TERMOSTATO 50-310 C	THERMOSTAT 50-310 C	-	-	1				
	Q151320000	TOR. ALOMADO M4X6 H.ZINCADO	CURVED SCREW M4X6 H. ZINC	-	-	2				
2	U673006000	CONMUTADOR	SWITCH	-	-	1				
	Q151320000	TOR. ALOMADO M4X6 H.ZINCADO	CURVED SCREW M4X6 H. ZINC	-	-	2				
3	R693055000	PILOTO VERDE 41227000C7	GREEN PILOT 41227000C7	-	-	1				
4	R693056000	PILOTO AMBAR 41227000A4	AMBER PILOT 41227000A4	-	-	1				
5	U673007000	CONMUTADOR EGO	EGO SWITCH	2	4	4				
	Q151320000	TOR. ALOMADO M4X6 H.ZINCADO	CURVED SCREW M4X6 H. ZINC	4	8	8				
6	J242802000	PORTAMANDOS COMPL. CE6-20	CONTROL HOLDER CE6-20	1	-	-				
6	J242804000	PORTAMANDOS COMPL. CE6-40	CONTROL HOLDER CE6-40	-	1	-				
6	J042803000	PORTAMANDOS COMPL. CE6-41	CONTROL HOLDER CE6-41	-	-	1				
7	R693056000	PILOTO AMBAR 41227000A4	AMBER PILOT 41227000A4	2	4	4				
8	U952101000	MANDO Ø6 CONMUTADOR-MESA	CONTROL Ø6 SWITCH-BENCH	2	4	4				
9	U952102000	MANDO Ø6 CONMUTAD.-HORNO	CONTROL Ø6 SWITCH-OVEN	-	-	1				
10	X482101000	MANDO Ø6 TERMOSTAO-HORNO	CONTROL Ø6 THERM. -OVEN	-	-	1				
11	J043002000	RESISTENCIA 1000W-230V SNACK	RESISTOR 1000W-230V SNACK	-	-	6				
12	J042603000	BASE RESISTENCIAS CE6-41	SUPP. RESISTORS	-	-	1				
	Q419005000	REMACHE 4X8 ALMG3 / ALUMINIO	RIVET 4X8 ALMG3 / ALUMINIUM	-	-	8				
13	R023013000	PRENSA ESTOPAS PG-21	STUFFING BOX PG-21	1	1	1				
14	R253044000	REGLETA AUXILIAR FV-122	AUXILIARY TERMINAL STRIP FV-	1	1	1				
	Q152004000	TORNIL. APLASTADO M5X13 A 304	FLAT HEADED SCREW M5x13 A 3	2	2	4				
15	J052805000	TAPA POSTERIOR CE6-41	REAR COVER CE6-41	-	-	1				
	Q152004000	TORNIL. APLASTADO M5X13 A 304	FLAT HEADED SCREW M5x13 A 3	-	-	4				
16	Z213007000	CONTACTOR 230 V. 50-60 HZ	CONTACTOR 230 V. 50-60 HZ	-	-	1				
	Z123018000	GUIA CONTACTOR L-55	CONTACTOR GUIDE L-55	-	-	1				
	Q419005000	REMACHE 4X8 ALMG3 / ALUMINIO	RIVET 4X8 ALMG3 / ALUMINIUM	-	-	2				

MOD.		COCINAS /RANGES		ZONA		CONJUNTO FUNCIONAL / FUNCTIONAL UNIT					PLANO		C-2378
ITEM	CODIGO	DENOMINACION	TEXTO	CE6-20	CE6-40	CE6-41							NOTAS
17	P453025000	BORNES 10 WDU-10203.O	TERMINALS 10 WDU-10203.O	3	3	3							
	P453026000	BORNE TIER 10 WPE-10103.O	TERMINAL TIER 10 WPE-10103.O	1	1	1							
	Z263302000	BORNA PASO AZUL	BLUE TAP TERMINAL	1	1	1							
	Z263303000	TOPE FINAL	END STOP	1	1	1							
	Z103083000	GUIA CONTACTOR L-73 "	CONTACTOR GUIDE L-73 "	1	1	1							
	Q419005000	REMACHE 4X8 ALMG3 / ALUMINIO	RIVET 4X8 ALMG3 / ALUMINIUM	2	2	2							

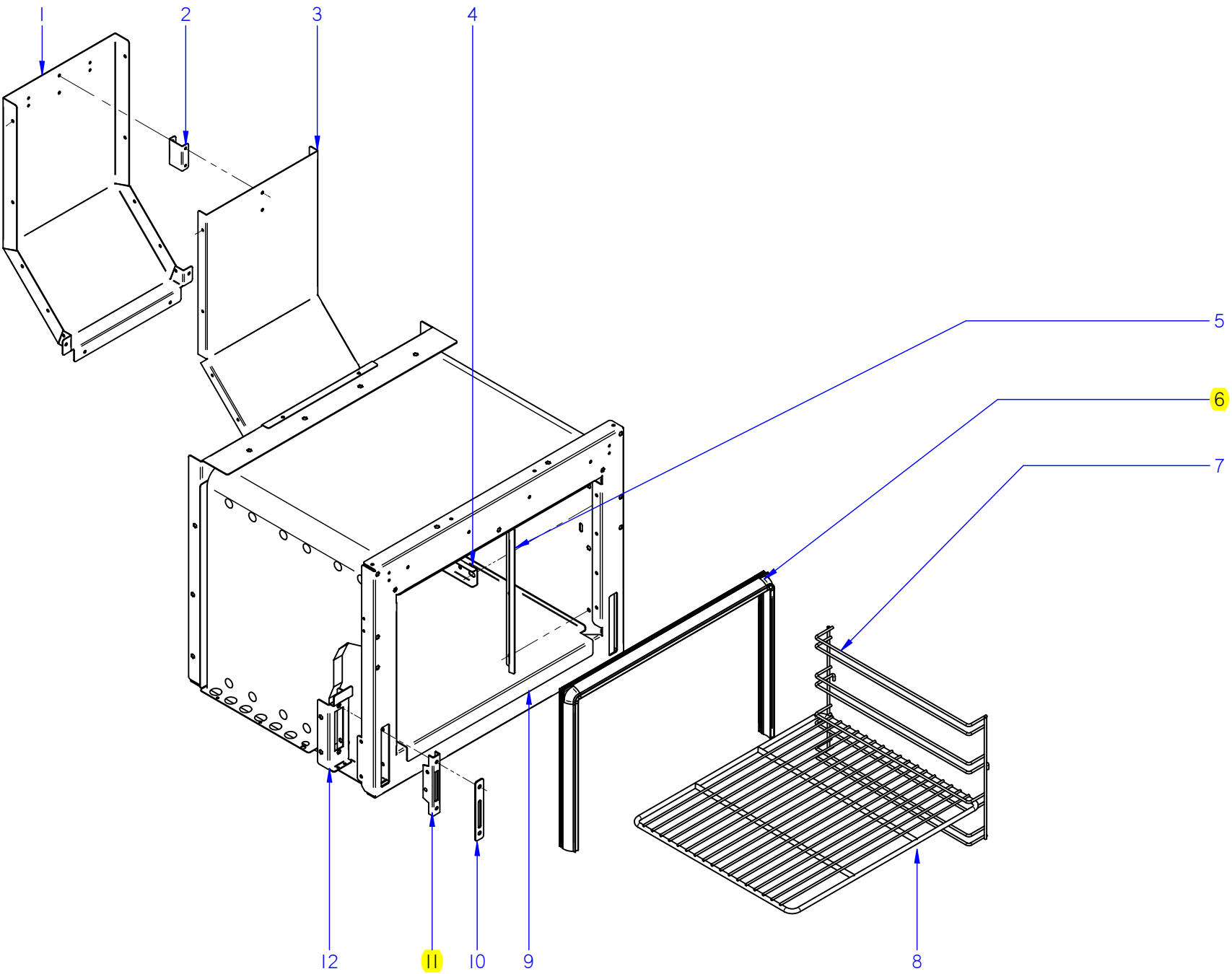

N plano	Firma	Fecha	Aparato	HORNO	Lamina	Fagor Industrial S. Coop.
C-2379	<i>(Firma)</i>	2009-06	COCINA CE6-41		4	Onate

ITEM MARCADO EN COLOR = REPUESTO RECOMENDADO  
 COLOURED ITEM = RECOMMENDED SPARE PART



MOD.		COCINAS /RANGES		ZONA	HORNO / OVEN					PLANO	C-2379
ITEM	CODIGO	DENOMINACION	TEXTO	CE6-41							NOTAS
1	J022602000	POSTERIOR CHIMENEA CG6-41	REAR FLUEPIPE CG6-41	1							
	Q419005000	REMACHE 4X8 ALMG3 / ALUMINIO	RIVET 4X8 ALMG3 / ALUMINIUM	4							
2	J022608000	SEPAR. CHIMENEA HORNO SNACK	SEPAR. OVEN FLUEPIPE SNACK	1							
	Q419005000	REMACHE 4X8 ALMG3 / ALUMINIO	RIVET 4X8 ALMG3 / ALUMINIUM	4							
3	J022603000	ANTERIOR CHIMENEA CG6-41	FRONT FLUEPIPE CG6-41	1							
	Q419005000	REMACHE 4X8 ALMG3 / ALUMINIO	RIVET 4X8 ALMG3 / ALUMINIUM	12							
4	U055644000	FIJACION BULBO	FASTENING BULB	1							
	Q412000000	REMACHE TUBULAR 4x8	TUBULAR RIVET 4x8	2							
5	J045610000	SUJECCION JUNTA PUERTA	DOOR SEAL FASTENING	2							
	Q012031000	TORNILLO EXAGONAL M5x10 A304	HEXAGONAL BOLT M5x10 A304	6							
	Q302022000	ARANDELA 16x6x1,2 A304	WASHER 16x6x1.2 A304	6							
6	J025610000	JUNTA HORNO COMPL.SNACK	OVEN DOOR SEAL SNACK	1							
7	J045609000	GUIA BANDEJAS HORNO SNACK	OVEN TRAY GUIDE SNACK	2							
8	J045613000	PARRILLA DE HORNO SNACK	SNACK OVEN GRILLE	1							
9	J045608000	SOLERA DE HORNO	OVEN FLOOR SNACK	1							ELIMINADA 02.11.2009
9	J045614000	SOLERA DE HORNO	OVEN FLOOR SNACK	1							INTRODUC. 02.11.2009
10	J045612000	EMBELLEC. GUIA BISAGRA SNACK	TRIM HINGE GUIDE SNACK	4							
	Q152045000	TORNILLO AMARRE M6X25	FASTENING BOLT M6X25	4							
11	U010512000	GUIA DE BISAGRA	HINGE GUIDE	2							
12	J042604000	SOPORTE BISAGRA PUERTA	SUPPORT DOOR HINGE	2							
	Q221342000	REMACHE EXAGONAL M5	HEXAGONAL RIVET M5	4							
	Q419005000	REMACHE 4X8 ALMG3 / ALUMINIO	RIVET 4X8 ALMG3 / ALUMINIUM	2							
	Q012031000	TORNILLO EXAGONAL M5X10 A304	HEXAGONAL BOLT M5X10 A304	2							
	Q302022000	ARANDELA Ø16X6X1.2 A.304	WASHER 16X6X1.2 A.304	5							

MOD.	COCINAS /RANGES	ZONA	VARIOS / MISCELLANEOUS	PLANO	
------	-----------------	------	------------------------	-------	--

ITEM	CODIGO	DENOMINACION	TEXTO	CE6-20	CE6-40	CE6-41					NOTAS
	J036501000	FOLLETO INSTRUCCIÓN. CE-600	INSTRUCTION LEAFLE. CE-600	1	1	1					
	J033004000	ESQUEMA TEORICO ADH. CE6-20	THEO. DIAGRAM LABELCE6-20	1	_	_					HB-80553
	J033005000	ESQUEMA TEORICO ADH. CE6-40	THEO. DIAGRAM LABELCE6-40	_	1	_					HC-81207
	U673001000	ESQUEMA TEORICO ADH. CE6-41	THEO. DIAGRAM LABELCE6-41	_	_	1					HC-71190
	J033007000	PLANO DE MONTAJE CE6-	CE6- ASSEMBLY PLAN	1	1	1					HC-81209
	U653003000	CABLEADO PORTAM. MESA	CONTROL HOLDER WIRING TAB	1	_	_					
	U673009000	CABLEADO BORNAS A CONMUT.	TERMINAL WIRING TO SWITCH	_	1	1					
	U803010000	CABLEADO A PLACA	WIRING TO PLATE	2	4	4					
	U803007000	CABLEADO HORNO CE-741	OVEN WIRING CE-741	_	_	1					
	U803008000	CABLEADO AUXILIAR CE-741	AUX. WIRING CE-741	_	1	1					

# CE6-20

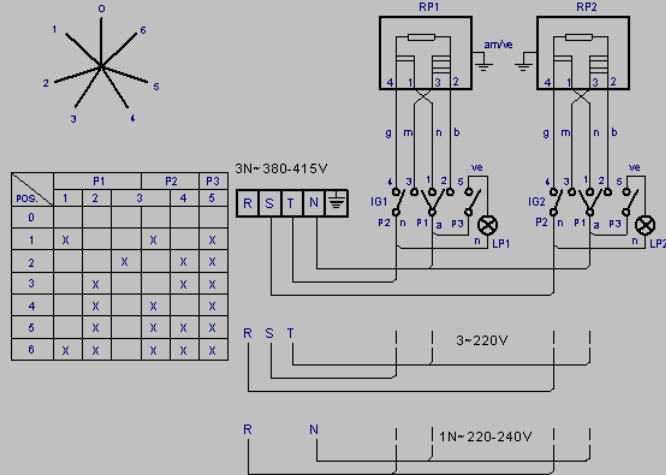

- m = marron-brown
- g = gris-grey
- n = negro-black
- a = azul-blue
- b = blanco-white
- ve = verde-green
- am/ve = amarillo/verde-yellow/green

-	<b>Theoretical diagram: CE6-20</b>		-	-	<b>J033004000</b>	-
Zk./N°	Pieza	Cant.	Material/Material	Klas. zk./N° Clas.	Gainazal akabera/Tratamiento	
Zk./N°	Aldaketa/Modificaciones		Nork proposatua/Propuesta de	Data/Fecha	Perdoi orokorrak Tolerancias generales	
-	-		-	-	-	
-	-		-	-	$\leq 5 \pm 0.2$   $50 - 100 \pm 0.8$ $5 + 25 \pm 0.4$   $> 100 \pm 1$ $25 + 50 \pm 0.6$   $\alpha \pm 1$	
-	-		-	-	-	
-	-		-	-	-	
Marratzua/Dibujado	<b>e.carrascal</b>	<b>2008-11-25</b>	 Fagor Industrial, Koop. Elk., Mugatua		Gainazal perdoia Mecanizado superficial	
Proiektatua/Proyectado	<b>e.carrascal</b>	<b>2008-11-25</b>			-	
Egiaztatua/Comprobado	<i>r.iberdi</i>	<b>2008-11-25</b>			-	
Eskala/Escala	<b>COOKING</b>				Plano Zk./Plano N° <b>HB-80553</b>	
-	Plano hau ezin daiteke erabili, ez berrizatu, gure baimenik gabe.				-	Zk. ord. du
-					-	Zk.gaitik ord.

# CE6-40

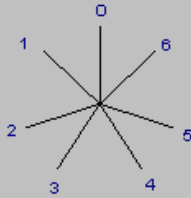

POS.	P1		P2		P3
	1	2	3	4	5
0					
1	X			X	X
2			X		X
3		X		X	X
4		X		X	X
5		X		X	X
6	X	X		X	X

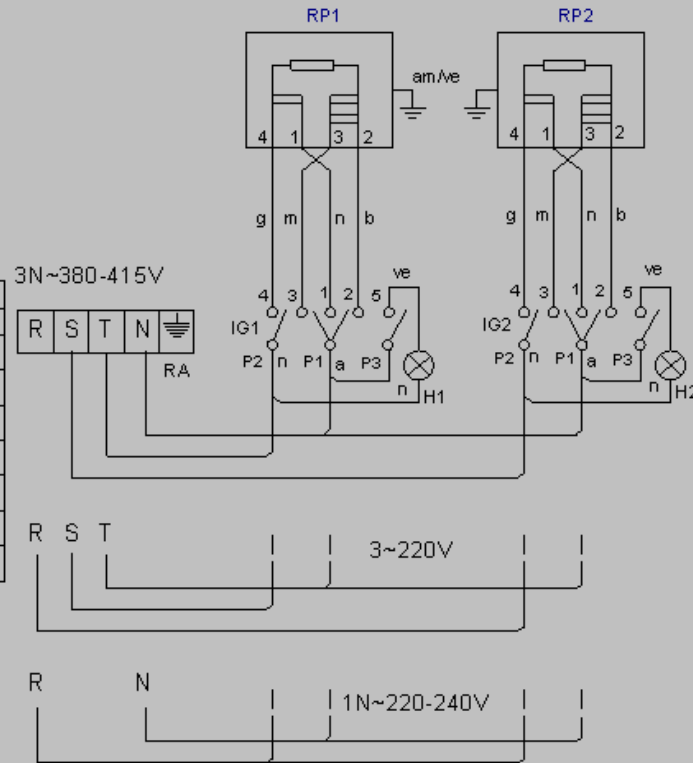

- m = marron-brown
- g = gris-grey
- n = negro-black
- a = azul-blue
- b = blanco-white
- ve = verde-green
- am/ve = amarillo/verde-yellow/green

HP1, HP2: Lámpara Calentamiento de Placas/Heating lamps  
 IG1, IG2: Conmutadores de placas eléctricas/Main switch (elect)  
 RP1, RP2: Placas eléctricas/Electrical plates

-	Theoretical diagram: CE6-40	-	-	J033005000	-	
Zk./Nº	Peza	Cant.	Materia/Material	Klas. zk./Nº Clas.	Gaiazal akaberatutarak	
Zk./Nº	Aldaketak/Modificaciones	Noiz proposatuta/Propuesta de	Data/Fecha	Perdiorokorrak Tolerantziak generales		
-	-	-	-	-	-	
-	-	-	-	-	-	
-	-	-	-	-	-	
-	-	-	-	-	-	
-	-	-	-	-	-	
-	-	-	-	-	-	
-	-	-	-	-	-	
	Sinaduta/Firma	Data/Fecha	 Fagor Indus trial, Koop. Ek., Murgatia		Gaiazal perdob Mecanizado superficial	
	Marraztutadutad	e. carrazal			2008-11-21	Plano Zk./Plano Nº HC-81207
	Proiektatuta/Proyectado	e. carrazal			2008-11-21	- Zk. ord. dt
	Egiaztatuta/Comprobado	J. Aguirre			2008-11-21	- Zk. gaitk. ord.
	Eskaia/Escala	-	<b>COOKING</b>			
	Plano kate ezko datuak erabiliz, ez berrikatu, gure balmea ikus gabe.					

# CE 941

# CE 741

# CE 641

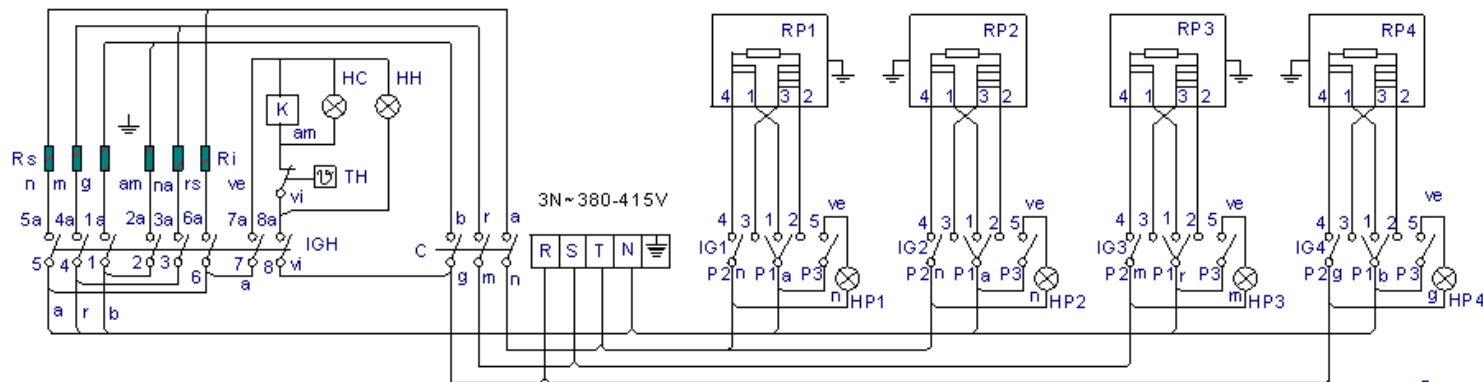

- r = rojo-red-rouge
- m = marron-brown-m arron
- g = gris-grey-gris
- n = negro-black-noir
- a = azul-blue-bleu
- b = blanco-white-blanc
- vi = violeta-violette-violet
- am = amarillo-yellow-jaune
- na = naranja-orange-orange
- rs = rosa-rose-pink
- ve = verde-green-vert
- am /ve = amarillo/verde-yellow w/green-jaune /vert

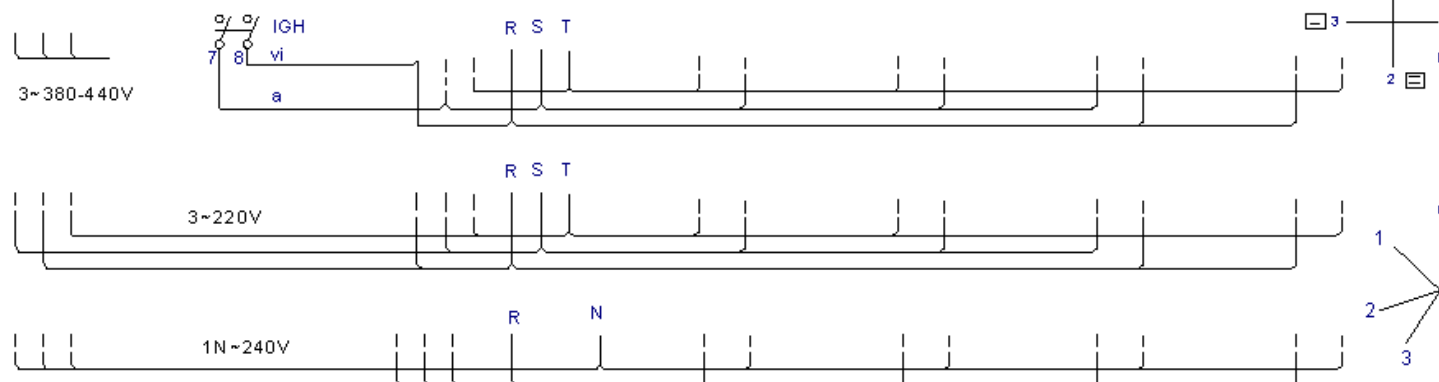

	1_2	3_4	5_6	7	8
	1a	2a	3a	4a	5a
0					
1	X		X	X	X
2	X	X	X	X	X
3	X	X		X	X

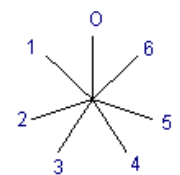

IG		P1	P2	P3
POS.	1	2	3	4
0				
1	X		X	X
2		X		X
3	X		X	X
4	X	X		X
5	X	X	X	X
6	X	X	X	X

- HPx: Lampara Calentamiento Placas / Heating lamp (electrical plates)
- HC : Lampara Calentamiento Horno / Heating lamp (oven)
- IGx: Conmutadores de placas electricas / Main switch (electrical plates)
- Ri : Resistencia Horno Inferior / Lower resistance (oven)
- TFR: Transformador / Transformer
- IGH : Conmutador General Horno / Oven main switch
- Rs: Resistencia Horno Superior / Top resistance (oven)
- K: Contactor / Contactor
- HH : Lam para Horno Encendido / Main lamp (oven)
- RPx: Placas electricas / Electrical plates

U673001000

Esquema teorico adhesivo		U-673001	
Nº	Pieza	Cart.	Material
Nº	Modificacio	Propuesta de	
		Fecha	
		Tole rancias generales	
		<3±	
		5-25±	
		25-50±	
		50-100±	
		>100±	
		X±	
Dibujado		Firma	Fecha
Proye ctado		Imp rtado	31.05.05
Com probado		FAGOR	
Escrib		Fagor Industrial, Koop. Ek., Miragiba	
1/1		COCINAS	
		Plano numero HC-71190	
		Sustituye al N°	
		Sustituido por	



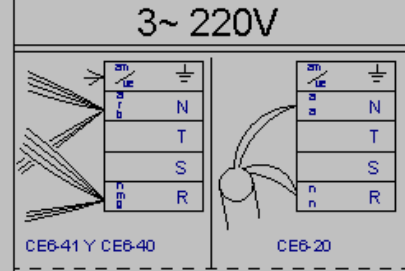
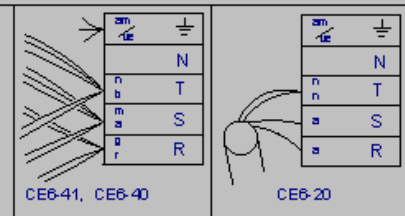
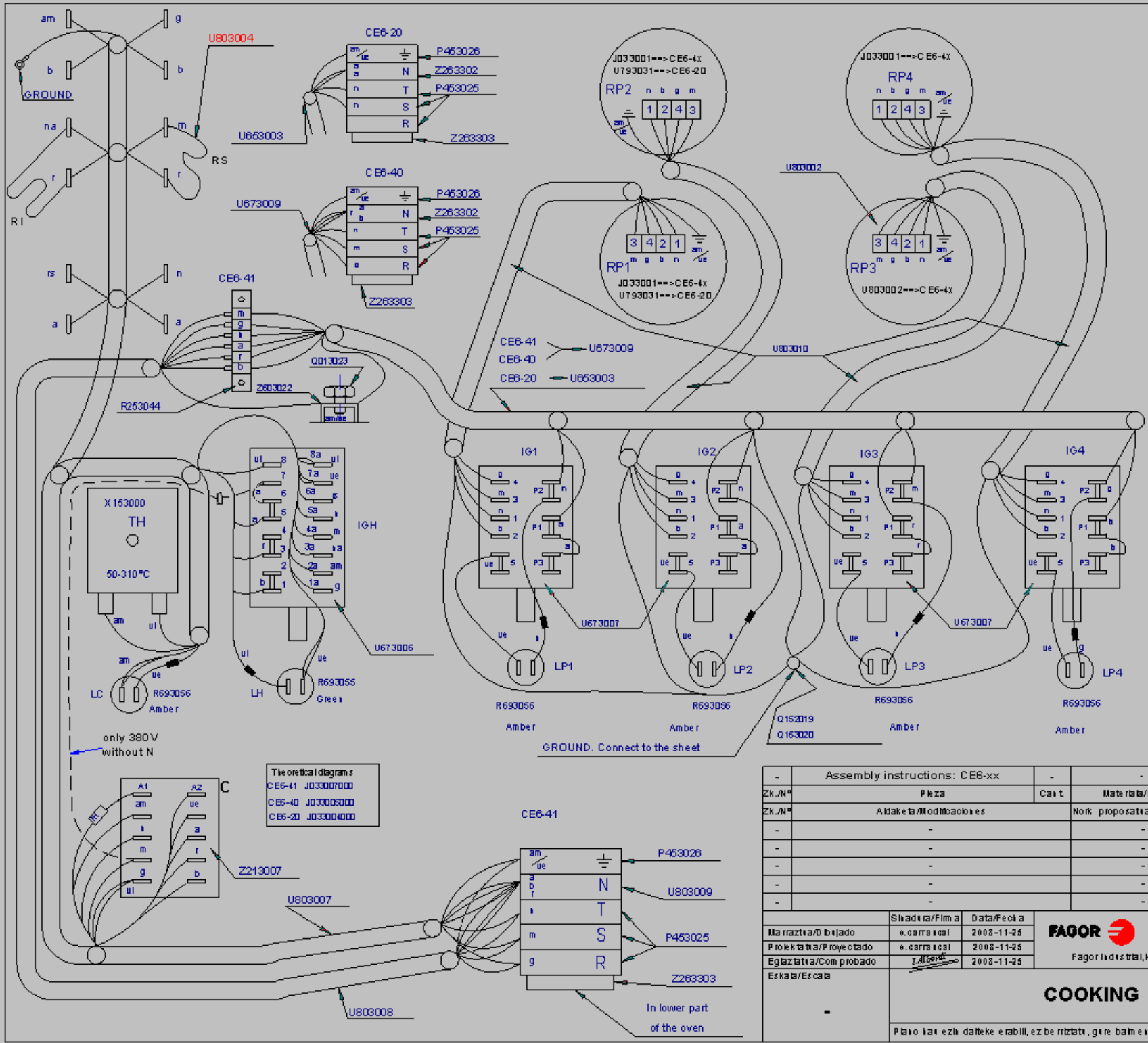

3 ~ 380-440V WITHOUT N  
 RP1, RP2, RP4= U803070  
 RP3, ..... = U803071  
 U803072= R:150KOhm1/4W  
 R1 U803073 = R:8K2Ohm6W

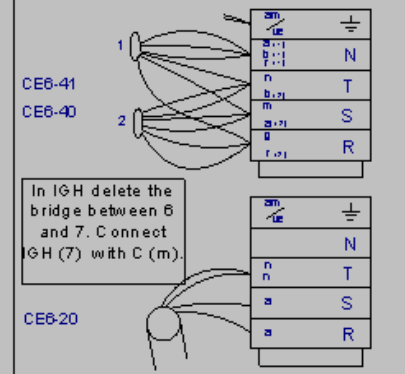

Theoretical diagrams  
 CE6-41 J033007000  
 CE6-40 J033005000  
 CE6-20 J033004000

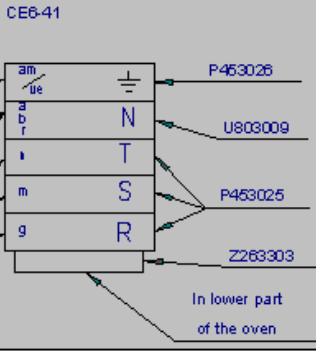

Assembly instructions: CE6-xx				J033007000		
Zk./N°	Plaza	Cau t.	Mate rias/Mate rial	Klas. zk./N° Cks	Gaiuzal akabe ra/T raiam ke rto	
Zk./N°	Aldake ta/Modifkazio nes		Nork proposatza/Prop esta de	Data/Fe cha	Pe diol orokorra k Tok e raiotas ge ne rales	
-	-	-	-	-	± 5 ± 0.2	50 + 100 ± 0.8
-	-	-	-	-	5 + 25 ± 0.4	> 100 ± 1
-	-	-	-	-	25 + 50 ± 0.6	Cl. ± 1

	Sikidra/Firma	Data/Fe cha	FAGOR		Gaiuzal pe diol b Me ka lizado spe ziala t
Ma rraztia/D b tado	e. carra sosal	2008-11-25	Fagor Indus trial, Koop. Ek., Mi gasta		Plazo Zk./Plazo N° HC-81209
Pro keta ta/Pro yek tado	e. carra sosal	2008-11-25			
Eg aztatza/Com probado	T. Al gort	2008-11-25			
Es kala/Es kala			<p><b>COOKING</b></p>		- Zk. ord. dt - Zk. gaitk ord.
Plazo kate eziz da ite ke erabili, ez be rritatzi, gure bal me k gabe.					