DESPIECE TECNICO

**Barbacoa a gas
Gas charcoal grills
Charcoal á gaz
Gas lavastein grills
Griglie pietra lavica a gas
Grelhadores de pedra l vica**

GAMA 900

Modelos:

BG9-05 PLUS

BG9-10 PLUS

Noviembre 2011 November

Revisado Junio 2013 June Revised



F A G O R I N D U S T R I A L

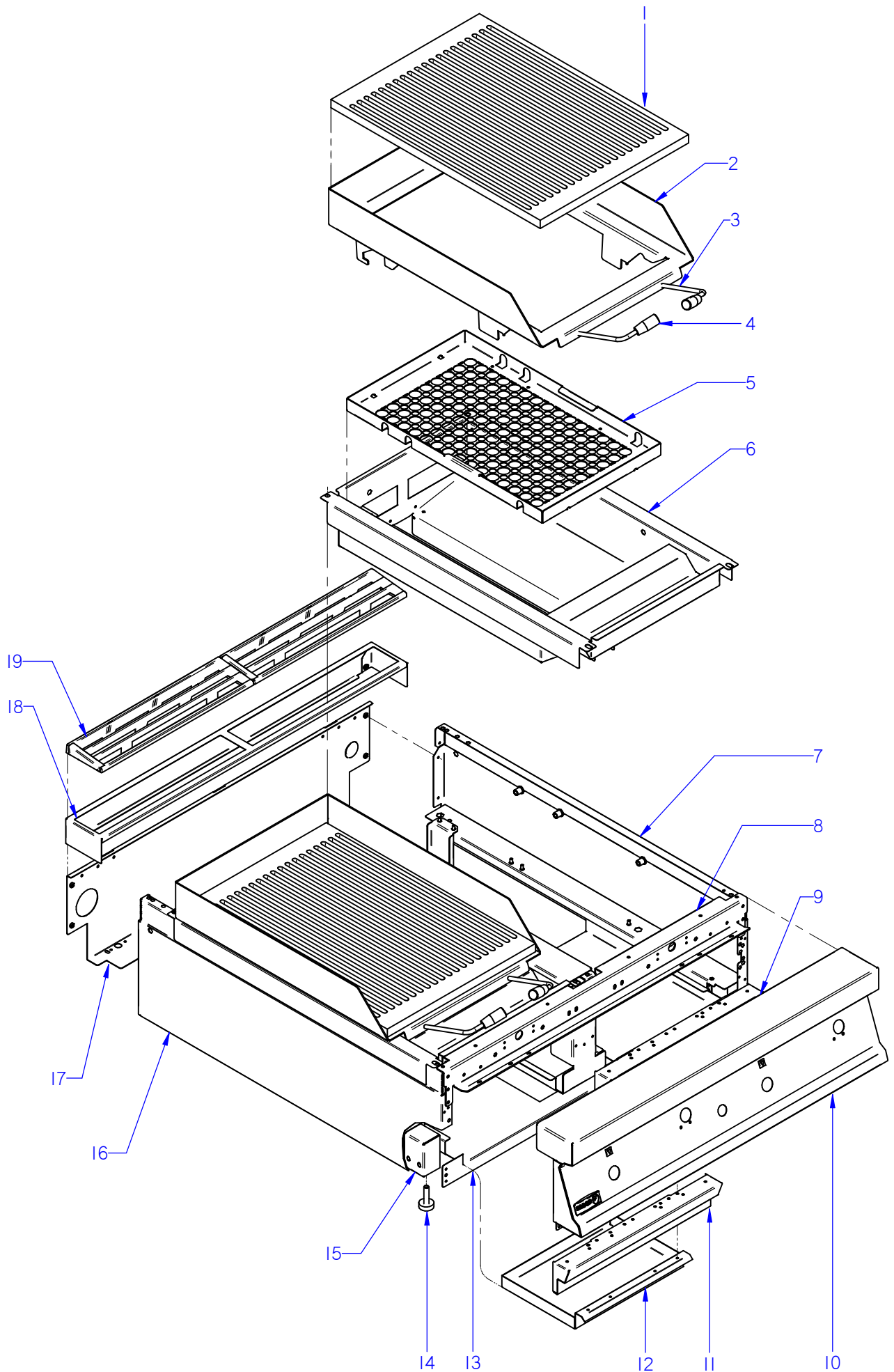

ITEM MARCADO EN COLOR = REPUESTO RECOMENDADO
 COLOURED ITEM = RECOMMENDED SPARE PART

Nº plano / N° plane	Firma	Fecha / Date	Denominación / Denomination: MUEBLE / FITTING	Lamina / Sheet	Fagor Industrial S.Coop. FAGOR
C-2932	<i>[Signature]</i>	2011-10	BARBACOA BG9-05 / 9-10 PLUS	1	Oñate

MOD.		BARBACOA / CHARCOAL GRILLS	ZONA / ZONE	MUEBLE / FITTING							PLANO DIAGRAM	C-2932	
ITEM	CODIGO REFERENCE	DENOMINACION	DENOMINATION	BG9-05 PLUS	BG9-10 PLUS						ELIMINADO ELIMINATED	INTRODUCID. INTRODUCED	NOTAS
1	T055470000	PARRILLA INOXIDABLE G900	STAINLESS STEEL GRILLE G900	1	2								
2	H015408000	SOPORTE PARRILLA G900	GRILLE SUPPORT G900	1	2						02.04.12		
2	12044203	SOPORTE PARRILLA G900 MEK	GRILLE SUPPORT G900 MEK	1	2							02.04.12	
	Q162040000	TUERCA EXAGONAL M6	HEXAGONAL NUT M6	2	4								
	Q261040000	ARANDELA MUELLE A6	SPRING WASHER A6	2	4								
3	H125419000	ASA BARBACOA 900	BARBECUE HANDLE 900	2	4						02.04.12		
4	T065460000	EMPUÑADURA	HANDLE	2	4								
5	H015407000	REJILLA INOX G900	INOX GRILLE G900	1	2								
	H012617000	LATERAL REJILLA AD	GRILLE SIDE AD	2	4								
	Q419005000	REMACHE 4x8 ALMG3 / ALUMINIO	RIVET 4X8 ALMG3 / ALUMINIUM	6	12								
6	H015413000	CAJA INTERIOR BG9-05 AD	INTERIOR BOX BG9-05 AD	1	2								
	N100322000	COJINETE AUTOLUBRICADO	SELF LUBRICATED BEARING	6	12								
	Q221343000	REMACHE EXAGONAL M6	HEXAGONAL RIVET M6	6	12								
	Q012032000	TORNILLO EXAGONAL M5X15 A304	HEXAGONAL BOLT M5X15	4	8								
	Q242030000	ARANDELA ABANICO A5 A304	FAN WASHER A5 A304	2	4								
	H125418000	TORNILLO SIST. ELEVACION	SCREW SYSTEM. LIFT	6	12								
7	R062810000	PANEL LATERAL DERECHO G-900	RIGHT SIDE PANEL G-900	1	1								
	Q221342000	REMACHE EXAGONAL M5	HEXAGONAL RIVET M5	9	9								
	Q419005000	REMACHE 4x8 ALMG3 / ALUMINIO	RIVET 4X8 ALMG3 / ALUMINIUM	3	3								
	Q162030000	TUERCA EXAGONAL M5	HEXAGONAL NUT M5	1	1								
	Q242030000	ARANDELA ABANICO A5 A304	FAN WASHER A5 A304	1	1								
8	R042611000	ESCUA. AMARRE ANTER.1/2 M AD	FRONT FAS. BRACKET 1/2 M AD	1	-								
8	U042610000	ESCUAD. AMARRE ANTERI.1 M AD	FRONT FAST. BRACKET 1 M AD	-	1								
	Q221342000	REMACHE EXAGONAL M5	HEXAGONAL RIVET M5	4	4								
	Q012032000	TORNILLO EXAGONAL M5X15 A304	HEXAGONAL BOLT M5X15 A304	6	6								
9	U965415000	ANTERIOR DE MESA 1/2 M	FRONT BENCH 1/2 M	1	-						03.10.11		
9	12006768	ANTERIOR DE MESA 1/2M (AD)	FRONT BENCH 1/2M (AD)	1	-							03.10.11	
9	S105403000	ANTERIOR DE MESA 1 M	FRONT BENCH 1 M	-	1								
	Q152004000	TORN. APLASTADO M5x13 A304	HEXAGONAL FLAT SCREW M5x13	2	2								
	Q302022000	ARANDELA 16x6x1,2 A304	WASHER 16x6x1.2 A304	2	2								

MOD.		BARBACOA / CHARCOAL GRILLS		ZONA / ZONE		MUEBLE / FITTING						PLANO DIAGRAM		C-2932	
ITEM	CODIGO REFERENCE	DENOMINACION	DENOMINATION	BG9-05 PLUS	BG9-10 PLUS							ELIMINADO ELIMINATED	INTRODUCID. INTRODUCED	NOTAS	
10	H012829000	PORTAMANDOS BG9-05 AD	CONTROL HOLDER BG9-05 AD	1	—										
10	H022814000	PORTAMANDOS BG9-10 AD	CONTROL HOLDER BG9-10 AD	—	1										
	U022836000	ESCUDO FAGOR	FAGOR EMBLEM G700	1	1										
	Q221023000	CLIP SUJECIÓN RÁPIDA Ø5	RAPID CONNECT CLIP Ø5	2	2										
	Q152004000	TORNILLO APLASTADO M5x13	FLAT HEAD SCREW M5X13	4	4										
S/Nº	12044303	LAGRIMA	IGNITOR WINDON COVER	1	1								01,04,12		
S/Nº	12025252	MUELLE 07777	SPRING 07777	1	1								01,04,12		
11	H012821000	ASA BANDEJA IZQUIER. DERECHA	LEFT TRAY HANDLE RIGHT	1	2										
	Q419005000	REMACHE 4x8 ALMG3 / ALUMINIO	RIVET 4X8 ALMG3 / ALUMINIUM	2	4										
12	H012620000	CAJON RECOGEGRAS. BG9-05 AD	GREASE COLLECTION DRAWER	1	2										
S/Nº	H012621000	REFUERZO CAJON AD	DRAWER REINFORCEMENT AD	1	2										
13	H012619000	BASE BG9-05 COMPLETA AD	BASE BG9-05 COMPLETE AD	1	—										
13	H022812000	BASE BG9-10 COMPLETA AD	BASE BG9-10 COMPLETE AD	—	1										
14	Z200107000	PATA REGULABLE	ADJUSTABLE LEG	4	4										
	Q221345000	REMACHE EXAGONAL M10	HEXAGONAL RIVET M10	4	4										
15	U962627000	ESCUADRA AMARRE PATA AD	LEG FASTENING BRACKET AD	2	2										
	X010503000	CIERRE MUELLE	LOCK SPRING	2	2										
	Q419007000	REMACHE TUBULAR C/V Ø3,2x6	TUBULAR RIVET C/V Ø3.2X6	4	4										
	Q162030000	TUERCA EXAGONAL M5	HEXAGONAL NUT M5	4	4										
	Q262030000	ARANDELA GROW. A5 A304	WASHER GROW. A5 A.304	4	4										
16	R062811000	PANEL LATERA IZQUIERDO G-900	LEFT SIDE PANEL G-900	1	1										
	Q221342000	REMACHE EXAGONAL M5	HEXAGONAL RIVET M5	9	9										
	Q419005000	REMACHE 4x8 ALMG3 / ALUMINIO	RIVET 4X8 ALMG3 / ALUMINIUM	3	3										
	Q162030000	TUERCA EXAGONAL M5	HEXAGONAL NUT M5	1	1										
	Q242030000	ARANDELA ABANICO A5 A304	FAN WASHER A5 A304	1	1										
17	R042838000	PANEL POSTERIOR 0,5 M	REAR PANEL 0.5 M	1	—										
17	U042805000	PANEL POSTERIOR 1 M	REAR PANEL 1 M	—	1										
	Q419005000	REMACHE 4x8 ALMG3 / ALUMINIO	RIVET 4X8 ALMG3 / ALUMINIUM	4	4										
	X010503000	CIERRE MUELLE	LOCK SPRING	2	2										
	Q419005000	REMACHE 4X8 ALMG3 / ALUMINIO	RIVET 4X8 ALMG3 / ALUMINIUM	4	4										

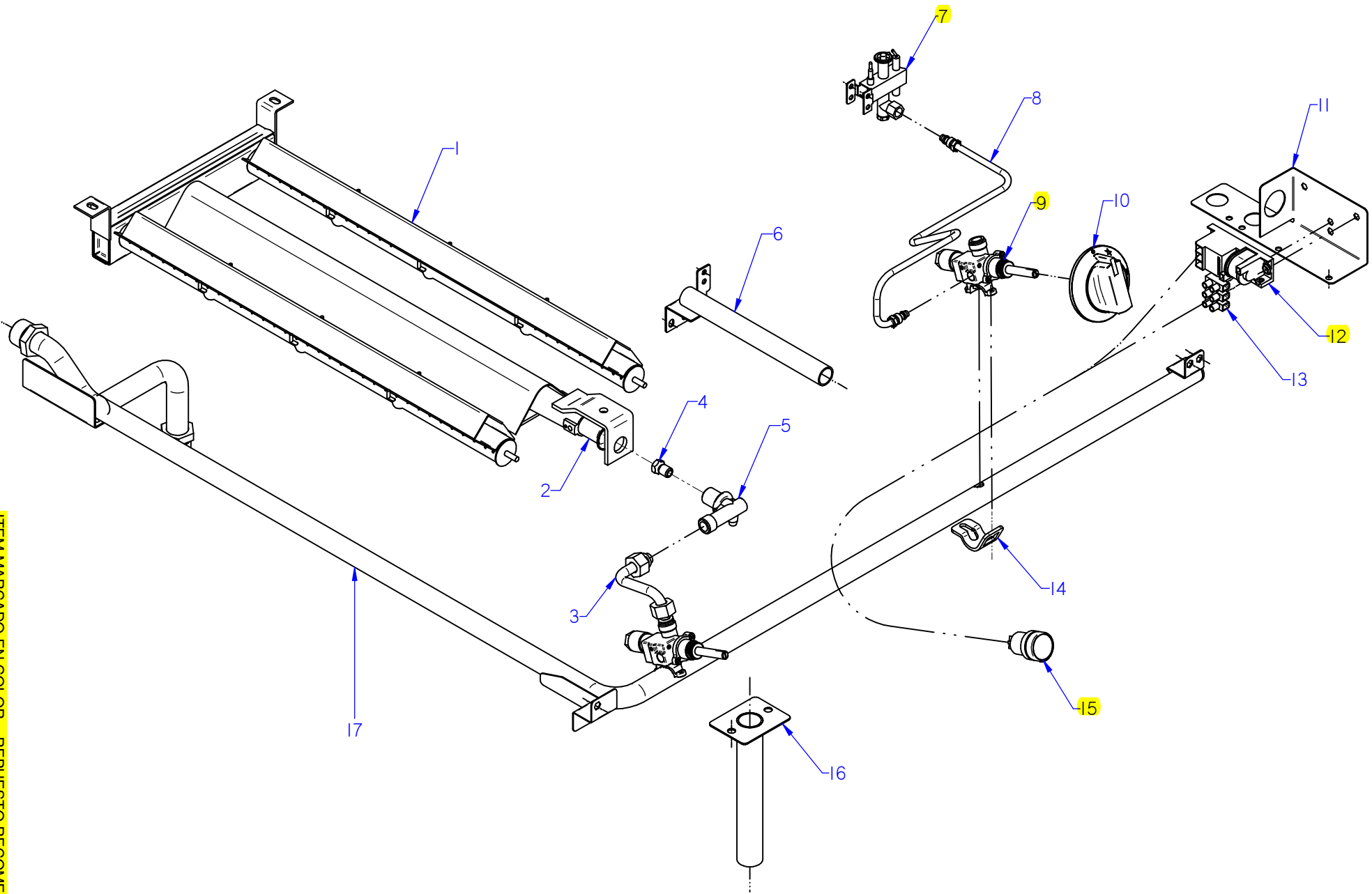



ITEM MARCADO EN COLOR = REPUESTO RECOMENDADO
 COLOURED ITEM = RECOMMENDED SPARE PART

Nº plano / N° plane	Firma	Fecha / Date	Denominación / Denomination:	Lamina / Sheet	Fogor Industrial S. Coop.
C-2933	<i>(Signature)</i>	2011-10	BARBACOA BG9-05 / 9-10 PLUS	2	Onate
			PARTIE FUNCIONAL / FUNCTIONAL PART		

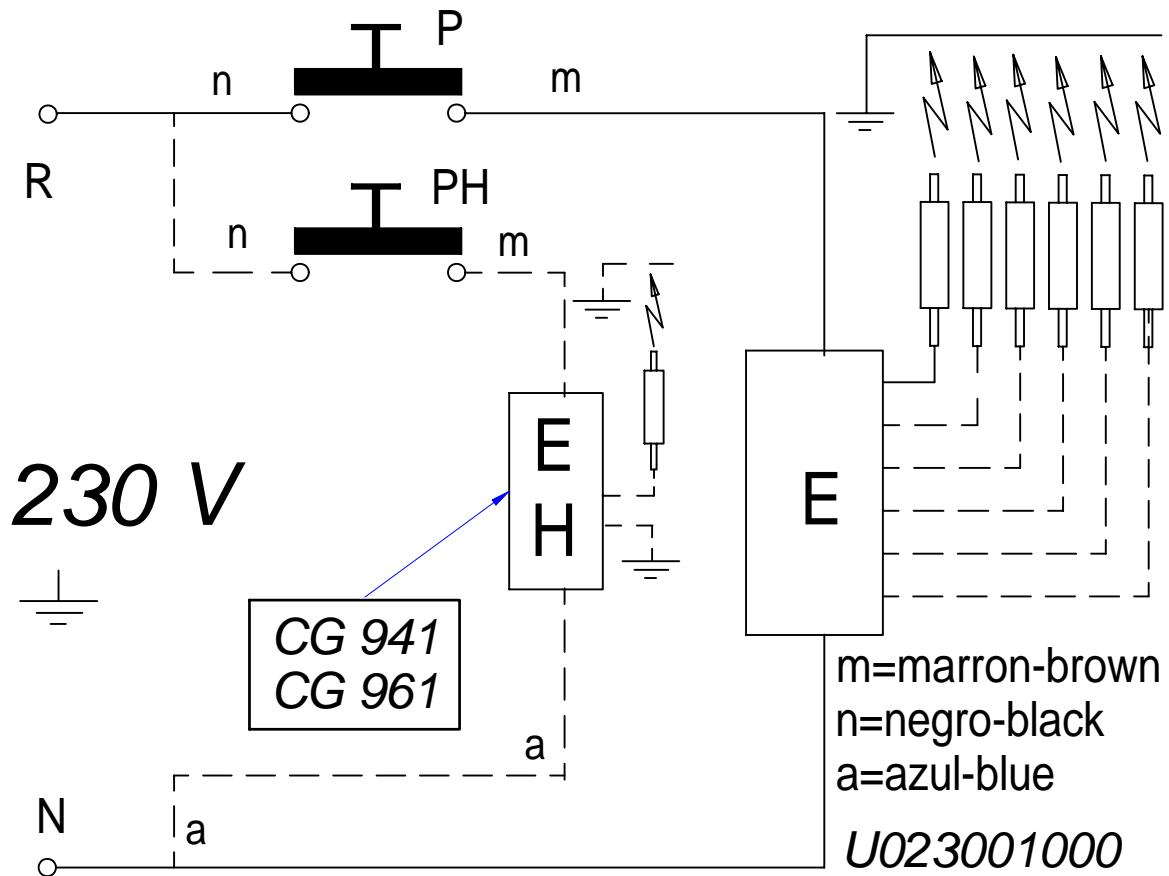

MOD.		BARBACOA / CHARCOAL GRILLS	ZONA / ZONE	PARTE FUNCIONAL / FUNCTIONAL PART							PLANO DIAGRAM	C-2933	
ITEM	CODIGO REFERENCE	DENOMINACION	DENOMINATION	BG9-05 PLUS	BG9-10 PLUS						ELIMINADO ELIMINATED	INTRODUCID. INTRODUCED	NOTAS
1	T055703000	QUEMADOR BARBACOA	BARBECUE BURNER	1	2								
	Q162030000	TUERCA EXAGONAL M5	HEXAGONAL NUT M5	1	2								
	Q302022000	ARANDELA 16x6x1,2 A304	WASHER 16x6x1.2 A304	1	2								
2	U325707000	REGULADOR DE AIRE	AIR REGULATOR	1	2								
	Q012031000	TORNILLO EXAGONAL M5x10 A304	HEXAGONAL BOLT M5x10 A304	1	2								
3	H015030000	CONDUCCION A QUEMADOR COM.	COMP. BURNER PIPE	1	2								
	Q153002000	TORNILLO TAPON	CAP BOLT	1	2								
	Q223019000	TUERCA 3/8 GAS LATÓN	NUT 3/8 GAS BRASS	1	2								
4	R302400000	TOBERA Ø 1,65 B-P	NOZZLE Ø 1.65 B-P	1	2								
4	U054400000	TOBERA Ø 2,5 G-N	NOZZLE Ø 2.5 G-N	1	2								
5	U915014000	PORTATOVERAS HORNO	OVEN NOZZLE HOLDER	1	2								
	Q306055000	ARANDELA16X10,3X1	WASHER 16X10.3X1	1	2								
	Q223019000	TUERCA 3/8 GAS LATÓN	NUT 3/8 GAS BRASS	1	2								
6	H015039000	TUBO ENCENDIDO COMPLETO	COMPLETE IGNITION PIPE	1	2								
S/Nº	X082831000	TAPA TUBO ENCENDIDO COMPLET	FULL COVER ON TUBE	1	2							31.03.12	
7	U322118000	PILOTO COMPLETO 100.062	COMPLETE PILOT LIGHT 100,062	1	2								
	U442137000	INYECTOR Ø 0,40 G-N	INJECTOR Ø 0.40 G-N	1	2								
	U222130000	TERMOPAR L=600	THERMOCOUPLE L=600	1	2								
	X022131000	BUJIA	SPARK PLUG	1	2								
8	H015026000	TUBO PILOTO BARBACOA	BARBECUE PILOT PIPE	1	2								
9	U022119000	GRIFO 18700 BY-PASS 1,30	TAP 18700 BY-PASS 1.30	1	2								
10	U022117000	MANDO MONTADO Ø8	MOUNTED CONTROL Ø8	1	2								
11	R042634000	SOPORTE CONEXIÓN	SUPPORT CONNECTION	1	1						03.06.12		
11	12045050	SOPORTE TREN-CHISPAS AD	SUPPORT TRAIN SPARK AD	1	1						10.09.12		
11	12046891	SOPORTE TREN-CHISPAS AD MEK	SUPPORT TRAIN SPARK AD MEK	1	1							31,10,11	
	Q012031000	TORNILLO EXAGONAL M5x10 A304	HEXAGONAL BOLT M5x10 A304	2	2								
	Q221342000	REMACHE EXAGONAL M5	HEXAGONAL RIVET M5	2	2								
12	X163014000	ENCENDEDOR PARA 2 BUJIAS	LIGHTER FOR 2 PLUGS	1	1								
13	Z713035000	REGLETA 6MM	C6MM STRIP	1	1								
	Q151301000	PHILIPS 8x5/8	PHILIPS 8X5/8	1	2								



-	Eskema teorikoa: ADVANCE		-	-	U023001000	-
Zk./Nº	Pieza		Cant.	Materiala/Material	Klas. zk/Nº Clas.	Gainazal akabera/Tratamiento
Zk./Nº	Aldaketa/Modificaciones			Nork proposatua/Propuesta de	Data/Fecha	Perdoi orokorrak Tolerancias generales
-	-	-	-	-	-	< 5 ± 0.2
-	-	-	-	-	-	50 ÷ 100 ± 0.8
-	-	-	-	-	-	5 ÷ 25 ± 0.4
-	-	-	-	-	-	>100 ± 1
-	-	-	-	-	-	25 ÷ 50 ± 0.6
-	-	-	-	-	-	α ± 1
Marratzua/Dibujado	Sinadura/Firma	Data/Fecha	FAGOR  Fagor Industrial, Koop. Elk, Mugatua			Gainazal perdoia Mecanizado superficial
Proiektatua/Proyectado	e.carrascal	2008-11-25				-
Egiaztatua/Comprobado	I. Alberdi	2008-11-25				-
Eskala/Escala	EGOSKETA					Plano Zk./Plano Nº HB-80558
-	Plano hau ezin daiteke erabili, ez berriztatu, gure baimenik gabe.					- Zk. ord. du
-						- Zk.gaitik ord.