

---

DESPIECE TECNICO

---

**Freidoras a gas  
Gas deep fat fryers  
Friteuses a gaz  
Gas-fritteusen  
Friggitrici a gas  
Fritadeiras a gás**

**GAMA 900**

**Modelos:**

**FG9-05 PLUS**

**FG9-10 PLUS**

**FG9-05 PLUS S**

***Noviembre 2011 November***

*Revisado Marzo 2014 March Revised*



---

F A G O R I N D U S T R I A L

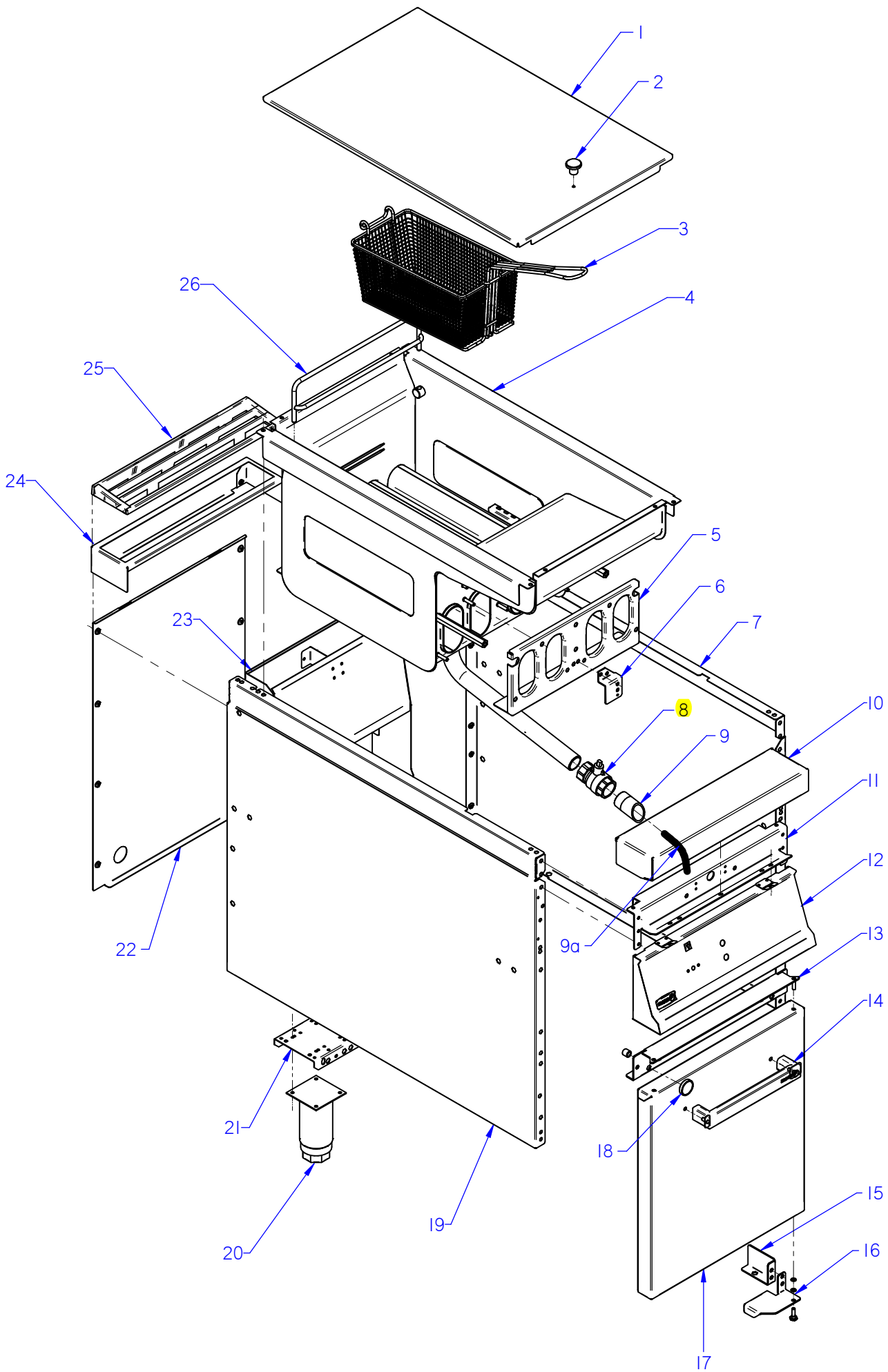

ITEM MARCADO EN COLOR = REPUESTO RECOMENDADO  
 COLOURED ITEM = RECOMMENDED SPARE PART

Nº plano / N° plane	Firma	Fecha / Date	Denominación / Denomination:	MUEBLE / FITTING	Lamina / Sheet	Fagor Industrial S.Coop. <b>FAGOR</b>
C-2915	<i>[Signature]</i>	2011-11	FREIDORAS FG9-05 / FG9-10 PLUS		1	Oñate

MOD.		FREIDORAS / FRYERS		ZONA / ZONE		MUEBLE / FITTING						PLANO DIAGRAM		C-2915
ITEM	CODIGO REFERENCE	DENOMINACION	DENOMINATION	FG9-05 PLUS	FG9-05 PLUS S	FG9-10 PLUS						ELIMINADO ELIMINATED	INTRODUCID. INTRODUCED	NOTAS
1	X166144000	TAPA DE CUBA	COVER FG9-00	1	1	2						03.10.11		
1	12040854	TAPA FREIDORA AD	TOP FRYER AD	1	1	2							03.10.11	
2	X166154000	POMO PARA TAPA	COVER KNOB	1	1	2								
	Q152004000	TORNIL. APLASTADO M5X13 A 304	FLAT HEADED SCREW M5x13 A 304	2	2	2								
	Q302022000	ARANDELA 16X6X1.2 A.304	WASHER 16X6X1.2 A.304	1	1	2								
3	X166525000	CESTILLO PEQUEÑO G900	SMALL BASKET G900	2	2	4								
S/Nº	X166522000	REJILLA COMPLETA	COMPLETE GRILLE	1	1	2								
4	X166156000	CUBA COMPLETA	COMPLETE TUB FG9-05	1	1	2								
	Q012043000	TORNILLO EXAGONAL M6X20	HEXAGONAL BOLT M6X20	1	1	2								
	Q302022000	ARANDELA 16X6X1.2 A.304	WASHER 16X6X1.2 A.304	1	1	2								
	Q012032000	TORNILLO EXAGONAL M5X15	HEXAGONAL BOLT M5X15	6	6	12								
5	12006775	PROTECCION FRENTE FG9-00	FRONT PROTECTION FG9-00	1	1	2								
6	12002561	SOPORTE PILOTO FG9-00	PILOT SUPPORT FG9-00	1	1	2								
7	X162814000	PANEL LATERAL DERECHO G900	RIGHT SIDE PANEL G900	1		2								
7	S142806000	PANEL LATERAL DERECHO G900S	RIGHT SIDE PANEL G900S		1									
	Q221343000	REMACHE EXAGONAL M6	HEXAGONAL RIVET M6	4	4	8								
	Q221342000	REMACHE EXAGONAL M5	HEXAGONAL RIVET M5	6	6	12								
8	X036107000	VALVULA ESFERA PASO TOTAL 1	SPHERICAL VALVE TOTAL PASS	1	1	2								
9	X506129000	PUNTA DESAGÜE (CUBA LIMPIA)	DRAINAGE POINT (CLEAN TUB)	1	1	2								
9a	11000006	TUBO SILICONA BAJA Tª D 38*31	SILICONE PIPE Tª D 38 * 31	1	1	2								
10	U965415000	ANTERIOR MESA 0,5 M AD	BENCH FRONT 0.5 M AD	1	1									
10	S105403000	ANTERIOR MESA 1 M AD	BENCH FRONT 1 M AD			1								
11	R042611000	ESCUA INTER AMAR ANTE 0,5 M	BRACKET INTER FASTE. FRONT	1	1									
11	U042610000	ESCUA INTER AMAR ANTE 1 M	BRACKET INTER FASTE. FRONT			1								
	Q012032000	TORNILLO EXAGONAL M5X15	HEXAGONAL BOLT M5X15	6	6	12								
	Q302022000	ARANDELA 16X6X1.2 A.304	WASHER 16X6X1.2 A.304	1	1	2								
	Q162040000	TUERCA EXAGONAL M6	HEXAGONAL NUT M6	2	2	4								
12	X502811000	PORTAMANDOS COMP. FG-905	CONTROL HOLDER FG-905	1	1									
12	X702811000	PORTAMANDOS COMP. FG-910	CONTROL HOLDER FG-910			1								
	U022836000	ESCUDO FAGOR	FAGOR EMBLEM	1	1	1								
	Q221023000	CLIP SUJECIÓN RÁPIDA Ø5	RAPID CONNECT CLIP Ø5	2	2	2								

MOD.		FREIDORAS / FRYERS		ZONA / ZONE		MUEBLE / FITTING						PLANO DIAGRAM		C-2915	
ITEM	CODIGO REFERENCE	DENOMINACION	DENOMINATION	FG9-05 PLUS	FG9-05 PLUS S	FG9-10 PLUS						ELIMINADO ELIMINATED	INTRODUCID. INTRODUCED	NOTAS	
13	X162669000	LISTON BISAGRA SUPERIOR DCH.	UPPER RIGHT HINGE STRIP	1	1	1									
S/Nº	X172602000	LISTON BISAGRA SUPERIOR IZDO.	UPPER LEFT HINGE STRIP			1									
	Q221342000	REMACHE EXAGONAL M5	HEXAGONAL RIVET M5	6	6	12									
	Q152004000	TORNIL. APLASTADO M5X13 A 304	FLAT HEADED SCREW M5x13 A 304	2	2	4									
14	Z710558000	ASA CAPOTA AD	AD HOOD HANDLE	1	1	2									
	Q162040000	TUERCA EXAGONAL M6	HEXAGONAL NUT M6	2	2	4									
	Q302022000	ARANDELA 16X6X1.2 A.304	WASHER 16X6X1.2 A.304	2	2	4									
15	U020526000	ESCUADRA REFUERZO BISAG DE.	R. HINGE REINFORCE. BRACKET	1		1									
15	U020527000	ESCUADRA REFUERZO BISAG IZQ.	L. HINGE REINFORCE. BRACKET			1									
	Q221343000	REMACHE EXAGONAL M6	HEXAGONAL RIVET M6	1		1									
	Q221342000	REMACHE EXAGONAL M5	HEXAGONAL RIVET M5	2		2									
	Q152004000	TORNIL. APLASTADO M5X13 A 304	FLAT HEADED SCREW M5x13 A 304	2		2									
16	U020511000	BISAGRA DERECHA INFERIOR	LOWER RIGHT HINGE	1		1									
16	X190504000	BISAGRA DERECHA INFERIOR SUS	LOWER RIGHT HINGE S		1										
16	U020517000	BISAGRA IZQUIERDA INFERIOR	LEFT LOWER HINGE			1									
	X960504000	TORNILLO DE GIRO M8	ROTATION BOLT M8	1	1	2									
	Q232040000	ARANDELA A6	WASHER A6	2	2	4									
	Q232050000	ARANDELA A8	WASHER A8	2	2	4									
	Q221342000	REMACHE EXAGONAL M5	HEXAGONAL RIVET M5	2		4									
	Q012042000	TORNILLO EXAGONAL M6X15	HEXAGONAL BOLT M6X15	2		4									
	Q302022000	ARANDELA 16X6X1.2 A.304	WASHER 16X6X1.2 A.304	2		4									
17	U960501000	PUERTA LATERAL AD	SIDE DOOR AD	1		2									
17	U492803000	PUERTA LATERAL SUS AD	SIDE DOOR AD		1										
S/Nº	U020537000	CONTRAPUERTA LATERAL G900	SIDE DOOR REVERSE G900	1		2									
S/Nº	U020514000	CONTRAPUERTA LATE. SUS AD	SIDE DOOR REVERSE US AD		1										
	Q412000000	REMACHE TUBULAR 4X8	RIVET 4X8	4	4	8									
18	X960501000	IMAN	MAGNET	2	2	4									
S/Nº	X960502000	FIJACION IMAN	MAGNET ATTACHMENT	2	2	4									
	Q012021000	TORNILLO EXAGONAL M4X10	HEXAGONAL BOLT M4x10	2	2	4									
	Q232020000	ARANDELA A4	WASHER A4	2	2	4									

MOD.		FREIDORAS / FRYERS		ZONA / ZONE		MUEBLE / FITTING						PLANO DIAGRAM		C-2915	
ITEM	CODIGO REFERENCE	DENOMINACION	DENOMINATION	FG9-05 PLUS	FG9-05 PLUS S	FG9-10 PLUS						ELIMINADO ELIMINATED	INTRODUCID. INTRODUCED	NOTAS	
19	X162813000	PANEL LATERAL IZQUIERDO G900	LEFT SIDE PANEL G900	1	-	2									
19	S142805000	PANEL LATERAL IZQUIERD. G900S	LEFT SIDE PANEL G900S	-	1	-									
	Q221342000	REMACHE EXAGONAL M5	HEXAGONAL RIVET M5	6	6	12									
	Q221343000	REMACHE EXAGONAL M6	HEXAGONAL RIVET M6	4	4	8									
20	X260151000	PATA REGULABLE	ADJUSTABLE LEG	4	-	4									
	Q411304000	REMACHE AVIBULB Ø 4,8	AVIBULB RIVET Ø 4.8	16	-	16									
21	E052603000	LISTON SOPORTE PATAS 1/2 M AD	LEG SUPPORT STRIP 1/2 M AD	2	-	-									
21	X492611000	LISTON SOPORTE PATAS 1 M	LEG SUPPORT STRIP 1 M	-	-	2									
	Q012042000	TORNILLO EXAGONAL M6X15	HEXAGONAL BOLT M6X15	8	8	8									
	Q302022000	ARANDELA 16X6X1.2 A.304	WASHER 16X6X1.2 A.304	1	1	1									
S/Nº	X192808000	BASE INFERIOR COMPLETA	COMPLETE LOWER BASE	-	1	-									
S/Nº	X492612000	REFUERZO BASE INFERIOR SUSP.	SUSP. LOWER BASE REINFORCE	-	1	-									
	Q012041000	TORNILLO EXAGONAL M6X10	HEXAGONAL BOLT M6X10	-	2	-									
	Q302022000	ARANDELA 16X6X1.2 A.304	WASHER 16X6X1.2 A.304	-	1	-									
	Q221342000	REMACHE EXAGONAL M5	HEXAGONAL RIVET M5	-	2	-									
22	X492801000	PANEL POSTERIOR 0,5 M AD	REAR PANEL 0.5 M AD	1	-	-									
22	X492804000	PANEL POSTERIOR 0,5 M SUS AD	REAR PANEL 0.5 M SUS AD	-	1	-									
22	X492802000	PANEL POSTERIOR 1M AD	FRYER REAR PANEL1M AD	-	-	1									
	Q419005000	REMACHE 4X8 ALMG3 / ALUMINIO	RIVET 4X8 ALMG3 / ALUMINIUM	8	6	12									
23	X492601000	ANTERIOR CHIMENEA AD	FLUEPIPE FRONT AD	1	1	2									
S/Nº	X492609000	POSTERIOR CHIMENEA FG AD	FG REAR FLUE AD	1	1	2									
S/Nº	X492610000	DISTANCIADOR CHIMENEA AD	FLUEPIPE SPACER AD	1	1	2									
	Q221343000	REMACHE EXAGONAL M6	HEXAGONAL RIVET M6	2	2	4									
	Q012041000	TORNILLO EXAGONAL M6X10	HEXAGONAL BOLT M6X10	2	2	4									
	Q302022000	ARANDELA 16X6X1.2 A.304	WASHER 16X6X1.2 A.304	1	1	2									
	Q419005000	REMACHE 4X8 ALMG3 / ALUMINIO	RIVET 4X8 ALMG3 / ALUMINIUM	20	20	20									
24	R205438000	SOPORTE EMBELLECEDOR 1/2M	1/2M TRIM SUPPORT	1	1	2									
25	R205425000	EMBELLECEDOR ESMALTE	1/2M TRIM	1	1	2									
26	X166527000	SOPORTE COMPLETO CESTILLO	COMPLETE BASKET SUPPORT	1	1	1									

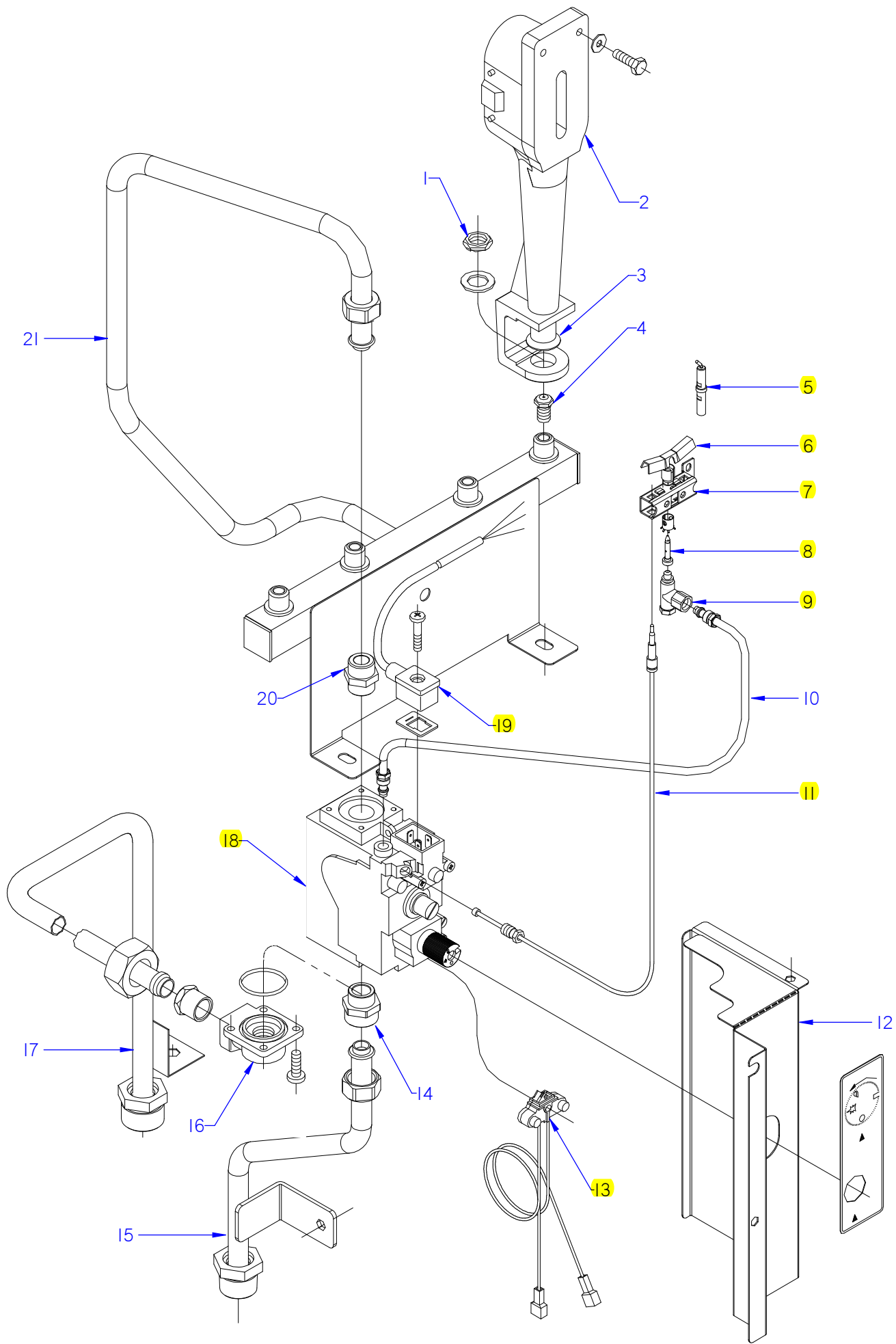

ITEM MARCADO EN COLOR = REPUESTO RECOMENDADO  
 COLOURED ITEM = RECOMMENDED SPARE PART

Nº plano / N° plane	Firma	Fecha / Date	Denominación / Denomination:	PARTE FUNCIONAL GAS / FUNTIONAL PART GAS	Lamina / Sheet	Fagor Industrial S.Coop. <b>FAGOR</b>
C-2916	<i>[Signature]</i>	2011-11	FREIDORAS	FG9-05 / FG9-10 PLUS	2	Oñate

MOD.		FREIDORAS / FRYERS		ZONA / ZONE		PARTE FUNCIONAL GAS / FUNCTIONAL PART GAS					PLANO DIAGRAM		C-2916	
ITEM	CODIGO REFERENCE	DENOMINACION	DENOMINATION	FG9-05 PLUS	FG9-05 PLUS S	FG9-10 PLUS						ELIMINADO ELIMINATED	INTRODUCID. INTRODUCED	NOTAS
1	Q223021000	TUERCA EXAGONAL 15x1	HEXAGONAL NUT 15x1	4	4	8								
	Q301322000	ARANDELA PLANA 27x17x2	FLAT WASHER 27x17x2	4	4	8								
2	X015700000	QUEMADOR COMPLETO FG9-00	COMPLETE BURNER FG9-00	4	4	8								
	Q012043000	TORNILLO EXAGONAL M6x20 A304	HEXAGONAL BOLT M6x20 A304	8	8	16								
	Q302022000	ARANDELA 16x6x1,2 A.304	WASHER 16X6X1.2 A.304	8	8	16								
3	U325707000	REGULADOR DE AIRE	AIR REGULATOR	4	4	8								
	Q012031000	TORNILLO EXAGONAL M5X10 A304	HEXAGONAL BOLT M5x10 A304	4	4	8								
4	12008939	TOBERA Ø 1,25 (BUTANO-PROP.)	NOZZLE Ø1.25 (BUT-PROP.)	4	4	8								
4	12008808	TOBERA Ø 1,80 (GAS NATURAL)	NOZZLE Ø1.80 (GAS NATURAL)	4	4	8						03.10.13		
4	12095788	TOBERA Ø 1,80	NOZZLE Ø1.80	4	4	8						03.10.13		
4	12017441	TOBERA Ø 1,75 (GAS NATURAL)	NOZZLE Ø1,75 (GAS NATURAL)	4	4	8							03.10.13	
5	X012101000	BUJIA 915.037	SPARK PLUG 915.037	1	1	2								
6	X012117000	PILOTO	PILOT	1	1	2								
7	X012113000	AMARRE TRAS. PILOTO 978.003	REAR FASTENING PILOT 978.003	1	1	2								
S/Nº	X012114000	AMARRE DELANT. PILOTO 978.004	FRONT FASTENING PILOT 978.004	1	1	2								
S/Nº	X012122000	REGULADOR DE AIRE 912.001	AIR CONTROL 912.001	1	1	2								
8	U442137000	INYECTOR Ø 0.4 (GAS NATURAL)	NOZZLE Ø0.4 (GAS NATURAL)	1	1	2								
9	X012126000	CUERPO SIN RAC. 901.210	BODY WITHOUT CONNEC. 901.210	1	1	2								
	X012116000	TORNILLO AMARRE PILOTO	PILOT FASTENING BOLT	2	2	4								
10	X165068000	TUBO PILOTO COMPLE G900	COMPL PILOT PIPE FG-900	1	1	2								
11	U562130000	TERMOPAR L=850	THERMOCOUPLE L=850	1	1	2								
12	X492608000	PROT. ELECTROVALVULA AD	SOLENOID VALVE PROT. AD	1	1	2						01.10.12		
12	12046978	PROTECTOR VALVULA	VALVE PROTECTOR	1	1	2							01.10.12	
S/Nº	X162617000	PEGATINA POSICION MANDO	CONTROL POSITION STICKER	1	1	2								
13	R275027000	CABLEADO ELECTROSIT 927.012	WIRING ELECTROSIT 927.012	1	1	2								
14	S502106000	MANGUITO DOBLE 3/4"- 1/2"	DOUBLE SLEEVE 3/4"- 1/2"	1	1	2						22.10.12		
14	12046984	MANGUITO DOBLE 1/2"-3/4"	DOUBLE SLEEVE 1/2"-3/4"	1	1	2							22.10.12	
15	X165065000	TUBO ENTRADA GENERAL	COMPL GAS INPUT FG-900	1	—	2						01.10.12		
15	12046983	ENTRADA GAS FREIDORA	GAS INPUT FRYER	1	—	2							01.10.12	
	Q152004000	TORNIL. APLASTADO M5X13 A 304	FLAT HEADED SCREW M5x13 A 304	2	—	4								
	Q306013000	ARANDELA PLANA Ø30.4X22.4X3	FLAT WASHER Ø30.4X22.4X3	1	—	2								





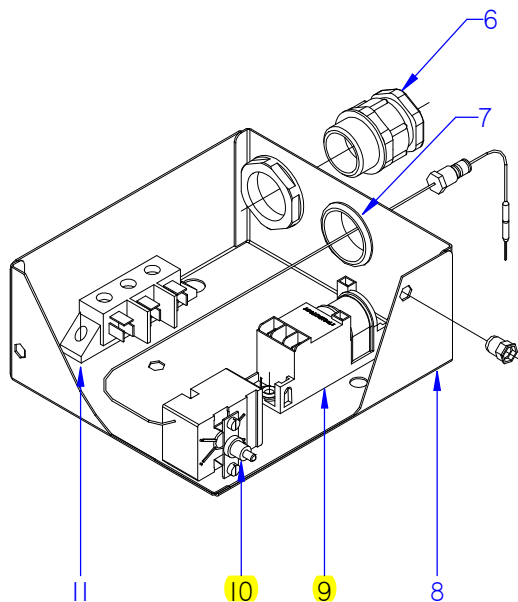
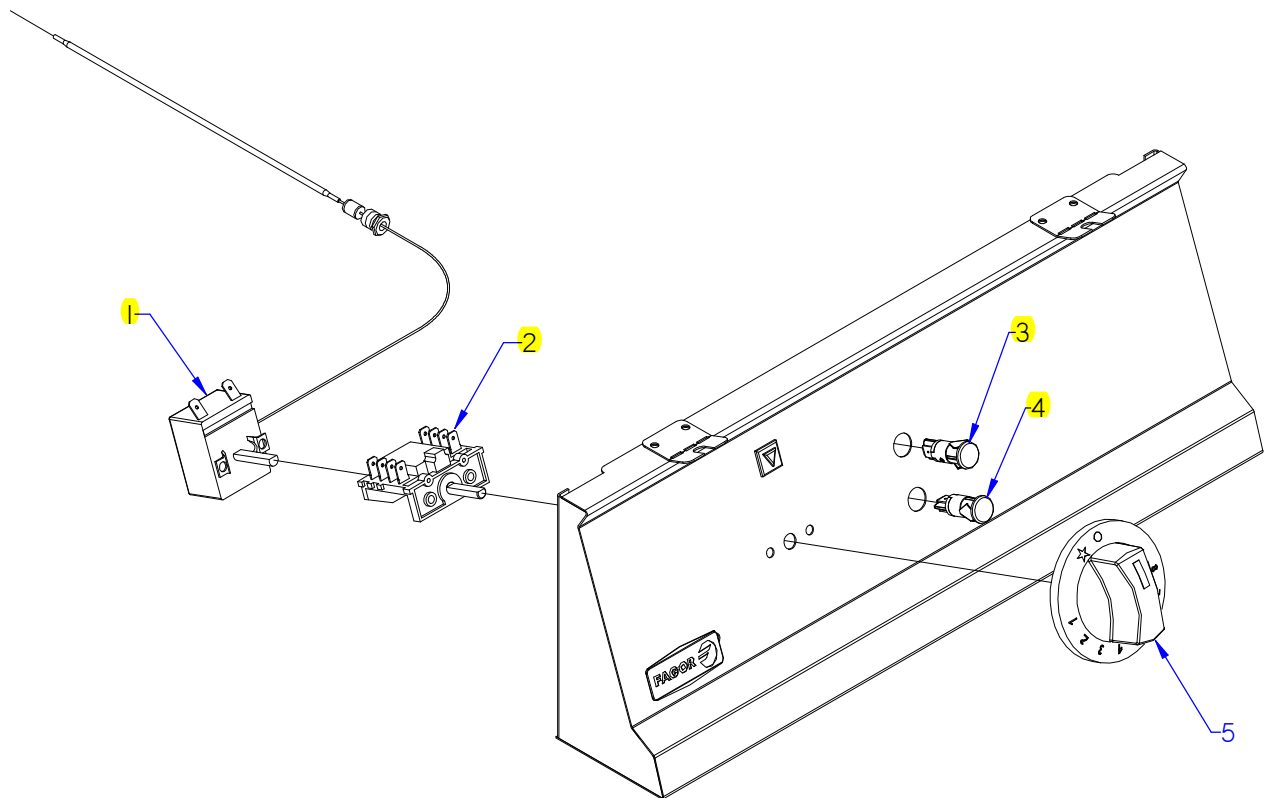

ITEM MARCADO EN COLOR = REPUESTO RECOMENDADO  
 COLOURED ITEM = RECOMMENDED SPARE PART

Nº plano / N° plane	Firma	Fecha / Date	Denominación / Denomination: FUNCIONAL ELECTRICA / FUNCTIONAL ELECTRICAL	Lamina / Sheet	Fagor Industrial S.Coop. <b>FAGOR</b>
C-2917	<i>[Signature]</i>	2011-11	FREIDORAS FG9-05 / FG9-10 PLUS	3	Oñate

MOD.		FREIDORAS / FRYERS		ZONA / ZONE		PARTE FUNCIONAL ELECTRICO FUNCTIONAL ELECTRICAL PART						PLANO DIAGRAM		C-2917	
ITEM	CODIGO REFERENCE	DENOMINACION	DENOMINATION	FG9-05 PLUS	FG9-05 PLUS S	FG9-10 PLUS						ELIMINADO ELIMINATED	INTRODUCID. INTRODUCED	NOTAS	
1	X163010000	TERMOSTATO	THERMOSTAT	1	1	2									
2	X163007000	CONMUTADOR ACOPLA TERMOS.	THERMOSTAT CONNECT SWITCH	1	1	2									
3	R693055000	PILOTO VERDE 41227000C7	GREEN PILOT 41227000C7	1	1	2						01.02.13			
3	12047390	PILOTO VERDE 230V AC 8KW 16MM	GREEN PILOT 230V AC 8KW 16MM	1	1	2							01.02.13		
4	R693056000	PILOTO AMBAR 41227000A4	AMBER PILOT 41227000A4	1	1	2						01.02.13			
4	12024669	PILOTO AMBAR Ø18	AMBER PILOT Ø18	1	1	2							01.02.13		
5	X503005000	MANDO MONTADO FG9 Ø6	CONTROL BUTTON Ø6 FG-900	1	1	2									
6	R023013000	PRENSA ESTOPAS	STUFFING BOX	1	1	2									
	R023025000	CONTRATUERCA GAES	COUNTERNUT GAES	1	1	2									
	R023026000	JUNTA DE GOMA GAES	RUBBER SEAL GAES	1	1	2									
7	X723014000	PASAMUROS Ø 30	WALL BUSHING Ø 30	1	1	2									
8	X493001000	CUADRO ELECTRICO FG9-00 AD	ELECTRIC PANEL FG9-00 AD	1	—	2						01.11.11			
8	12041209	CUADRO ELECTR. FG9-00 AD MEK	ELECTRIC PANEL FG9-00 A MEK	1	—	2							01.11.11		
8	X493003000	CUADRO ELECTRICO FG-905 S AD	ELECTRIC PANEL FG9-00 S AD	—	1	—									
S/Nº	X493002000	TAPA CUADRO ELECTRICO AD	ELECTRIC PANEL COVER AD	1	—	2						01.11.11			
S/Nº	12041208	TAPA CUADRO ELECTRI. AD MEK	ELECTRIC PANEL COVER ADMEK	1	—	2							01.11.11		
S/Nº	X493004000	TAPA CUADRO ELECTR.. AD SUSP	ELECTR. PANEL COVER AD SUS	—	1	—									
	Q152004000	TORNILLO APLASTADO M5x13 A304	FLAT HEADED BOLT M5x13 A304	9	9	12									
	Q221342000	REMACHE EXAGONAL M5	HEXAGONAL RIVET M5	3	3	12									
9	X163014000	ENCENDEDOR PARA 2 BUJIAS	LIGHTER FOR 2 PLUGS	1	1	2									
	Q082005000	TORNILLO CHAP. 4,2X13 4.2X13	PLATE BOLT 4.2X13 4.2X13	2	2	4									
10	X163001000	TERMOSTATO LIMITADOR	THERMOSTAT LIMITER	1	1	2						01.04.13			
10	12048400	TERMOSTATO SEGURIDAD 245°C	SECURITY THERMOSTAT 245°C	1	1	2							01.04.13		
	Q151320000	TORNILLO ALOM. M4X6 H.ZINCAD.	CURVED SCREW M4x6 H,ZINC.	2	2	4									
11	U183046000	REGLETA AUXILIAR	AUXILIARY STRIP	1	1	2									
	Q152004000	TORNILLO APLASTADO M5x13 A304	FLAT HEADED BOLT M5x13 A304	2	2	4									





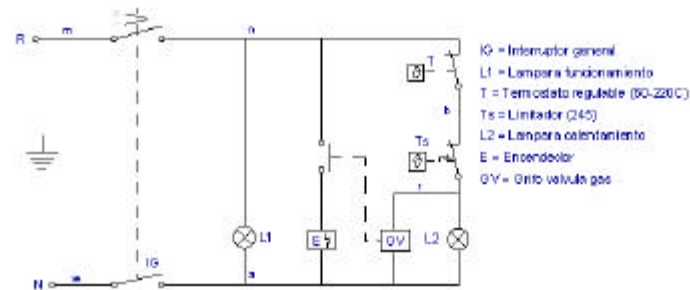

IG = Interruptor general  
 L1 = Lámpara funcionamiento  
 T = Termostato regulable (90-220°C)  
 Ts = Limitador (245)  
 L2 = Lámpara calentamiento  
 E = Encendedor  
 GV = Orificio válvula gas

m=marco-beige-marsh  
 n=negro-black-noir  
 r=rojo-red-rouge  
 b=blanco-white-blanc  
 v=verde-green-vert  
 g=gris-grey-gris  
 a=azul-blue-bleu

X 163005

**NOTAS:**

- GRADACIONES: C COLOR NEGRO
- FONDO: COLOR NATURAL
- LA PLACA SERA AUTOADHESIVA POR LA CARA POSTERIOR Y RECUBIERTO POR UN PAPEL PROTECTOR.
- LAS INSCRIPCIONES RESISTIR AN SIN MODIFICACION APRECIABLE, EL FROTAMIENTO DURANTE 15 SEG. DE UN ALGODON EMPAPADO EN GASOLINA.

ALUMINIO BRILLO (SOLID-FOIL)  
 e=ALUMINIO+PROTECTOR=0,2

4025  
-001

Esquema teorico adhesivo FG-91/20		X163005				
Nº	Pieza	Materia	Nº Clasificación	Acabado		
Nº	Modificación	Propuesta de	Fecha	Tolerancias generales		
1	Modificación general (pasar a fabri inferior)	Plazaola	23-5-97	<math>\leq +</math> 5 -25 ± 26 -50 ±	50-100 ± >100 ± <math>\times \pm</math>	
	Firma	Fecha			Mecanizado superficial	
	Dibujado	JON	93-9-14	Fagor Industrial, Rosp. E.I., Mugeluz		
	Proyectado			Plano numero <b>HB-14457-1</b>		
	Concebido			Sustituye al Nº		
	Escala	<b>FREIDORAS</b>			Sustituido por	
		Placa fabricada en metal cromado por laminación en caliente				