

Freidoras eléctricas
Electric fryers
Friteuse électrique
Elektro fritteusen
Friggitrici elettriche
Fritadeiras elétricas

GAMA 900

Modelos:

FE9-05 AD

FE9-10 AD

Noviembre 2011 November



F A G O R I N D U S T R I A L

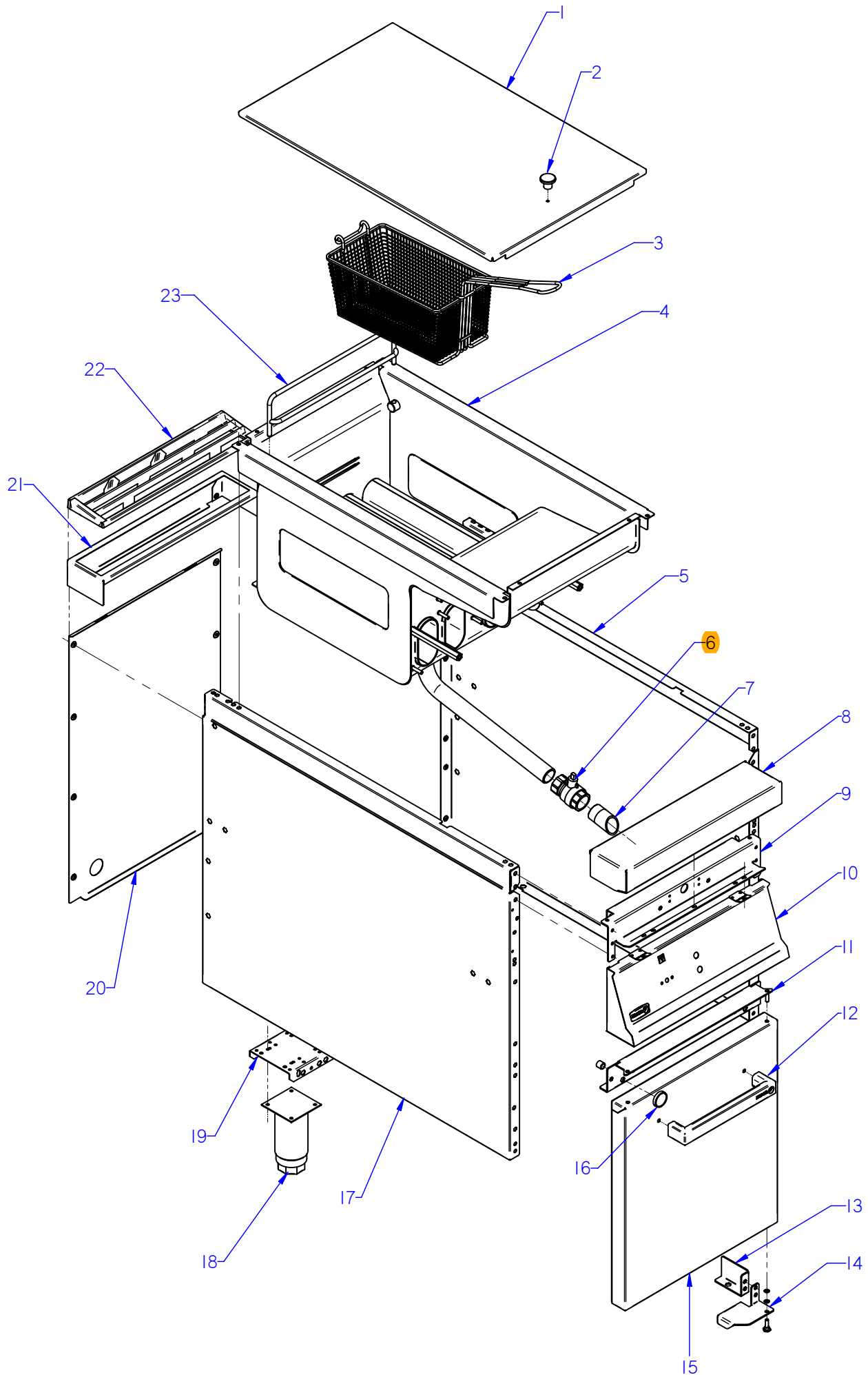

ITEM MARCADO EN COLOR = REPUESTO RECOMENDADO
 COLOURED ITEM = RECOMMENDED SPARE PART

Nº plano / N ° plane	Firma	Fecha / Date	Denominación / Denomination:	MUEBLE / FITTING	Lamina / Sheet	Fagor Industrial S.Coop. FAGOR
C-2918	<i>[Signature]</i>	2011-11	FREIDORAS FE9-05 AD / 10 AD		1	Oñate

MOD.		FREIDORAS / FRYERS	ZONA / ZONE	MUEBLE / FITTING							PLANO DIAGRAM	C-2918	
ITEM	CODIGO REFERENCE	DENOMINACION	DENOMINATION	FE9-05 AD	FE9-05 S AD	FE9-10 AD					ELIMINADO ELIMINATED	INTRODUCID. INTRODUCED	NOTAS
1	X186113000	TAPA DE CUBA	COVER FG9-00	1	1	2							
2	X166154000	POMO PARA TAPA	COVER KNOB	1	1	2							
	Q152004000	TORNIL. APLASTADO M5X13 A 304	FLAT HEADED SCREW M5x13 A 304	2	2	2							
	Q302022000	ARANDELA 16X6X1.2 A.304	WASHER 16X6X1.2 A.304	1	1	2							
3	X166525000	CESTILLO PEQUEÑO G900	SMALL BASKET G900	2	2	4							
S/Nº	X166522000	REJILLA COMPLETA	COMPLETE GRILLE	1	1	2							
4	X186114000	CUBA COMPLETA	COMPLETE TUB FG9-05	1	1	2							
	Q012043000	TORNILLO EXAGONAL M6X20	HEXAGONAL BOLT M6X20	1	1	2							
	Q302022000	ARANDELA 16X6X1.2 A.304	WASHER 16X6X1.2 A.304	1	1	2							
	Q012032000	TORNILLO EXAGONAL M5X15	HEXAGONAL BOLT M5X15	6	6	12							
5	X162814000	PANEL LATERAL DERECHO G900	RIGHT SIDE PANEL G900	1	—	2							
5	S142806000	PANEL LATERAL DERECHO G900S	RIGHT SIDE PANEL G900S	—	1	—							
	Q221343000	REMACHE EXAGONAL M6	HEXAGONAL RIVET M6	4	4	8							
	Q221342000	REMACHE EXAGONAL M5	HEXAGONAL RIVET M5	6	6	12							
6	X036107000	VALVULA ESFERA PASO TOTAL 1	SPHERICAL VALVE TOTAL PASS	1	1	2							
7	X506129000	PUNTA DESAGÜE (CUBA LIMPIA)	DRAINAGE POINT (CLEAN TUB)	1	1	2							
8	U965415000	ANTERIOR MESA 0,5 M AD	BENCH FRONT 0.5 M AD	1	1	—							
8	S105403000	ANTERIOR MESA 1 M AD	BENCH FRONT 1 M AD	—	—	1							
	Q152004000	TORNIL. APLASTADO M5X13 A 304	FLAT HEADED SCREW M5x13 A 304	2	2	2							
	Q302022000	ARANDELA 16X6X1.2 A.304	WASHER 16X6X1.2 A.304	1	1	1							
9	R042611000	ESCUA INTER AMAR ANTE 0,5 M	BRACKET INTER FASTE. FRONT	1	1	—							
9	U042610000	ESCUA INTER AMAR ANTE 1 M	BRACKET INTER FASTE. FRONT	—	—	1							
	Q221342000	REMACHE EXAGONAL M5	HEXAGONAL RIVET M5	3	3	6							
	Q012032000	TORNILLO EXAGONAL M5X15	HEXAGONAL BOLT M5X15	6	6	12							
	Q302022000	ARANDELA 16X6X1.2 A.304	WASHER 16X6X1.2 A.304	1	1	2							
	Q162040000	TUERCA EXAGONAL M6	HEXAGONAL NUT M6	2	2	4							
10	X502811000	PORTAMANDOS COMP. FG-905	CONTROL HOLDER FG-905	1	1	—							
10	X702811000	PORTAMANDOS COMP. FG-910	CONTROL HOLDER FG-910	—	—	1							
	Q152004000	TORNIL. APLASTADO M5X13 A 304	FLAT HEADED SCREW M5x13 A 304	2	2	2							
	U022836000	ESCUDO FAGOR	FAGOR EMBLEM	1	1	1							
	Q221023000	CLIP SUJECIÓN RÁPIDA Ø5	RAPID CONNECT CLIP Ø5	2	2	2							

MOD.		FREIDORAS / FRYERS	ZONA / ZONE	MUEBLE / FITTING							PLANO DIAGRAM	C-2918		
ITEM	CODIGO REFERENCE	DENOMINACION	DENOMINATION	FE9-05 AD	FE9-05 S AD	FE9-10 AD						ELIMINADO ELIMINATED	INTRODUCID. INTRODUCED	NOTAS
11	X162669000	LISTON BISAGRA SUPERIOR DCH.	UPPER RIGHT HINGE STRIP	1	1	1								
S/Nº	X172602000	LISTON BISAGRA SUPERIOR IZDO.	UPPER LEFT HINGE STRIP	-	-	1								
	Q221342000	REMACHE EXAGONAL M5	HEXAGONAL RIVET M5	6	6	12								
	Q152004000	TORNIL. APLASTADO M5X13 A 304	FLAT HEADED SCREW M5x13 A 304	2	2	4								
12	Z710558000	ASA CAPOTA AD	AD HOOD HANDLE	1	1	2								
	Q162040000	TUERCA EXAGONAL M6	HEXAGONAL NUT M6	2	2	4								
	Q302022000	ARANDELA 16X6X1.2 A.304	WASHER 16X6X1.2 A.304	2	2	4								
13	U020526000	ESCUADRA REFUERZO BISAG DE.	R. HINGE REINFORCE. BRACKET	1	-	1								
13	U020527000	ESCUADRA REFUERZO BISAG IZQ.	L. HINGE REINFORCE. BRACKET	-	-	1								
	Q221343000	REMACHE EXAGONAL M6	HEXAGONAL RIVET M6	1	-	1								
	Q221342000	REMACHE EXAGONAL M5	HEXAGONAL RIVET M5	2	-	2								
	Q152004000	TORNIL. APLASTADO M5X13 A 304	FLAT HEADED SCREW M5x13 A 304	2	-	2								
14	U020511000	BISAGRA DERECHA INFERIOR	LOWER RIGHT HINGE	1	-	1								
14	X190504000	BISAGRA DERECHA INFERIOR SUS	LOWER RIGHT HINGE S	-	1	-								
14	U020517000	BISAGRA IZQUIERDA INFERIOR	LEFT LOWER HINGE	-	-	1								
	X960504000	TORNILLO DE GIRO M8	ROTATION BOLT M8	1	1	2								
	Q232040000	ARANDELA A6	WASHER A6	2	2	4								
	Q232050000	ARANDELA A8	WASHER A8	2	2	4								
	Q221342000	REMACHE EXAGONAL M5	HEXAGONAL RIVET M5	2	-	4								
	Q012042000	TORNILLO EXAGONAL M6X15	HEXAGONAL BOLT M6X15	2	-	4								
	Q302022000	ARANDELA 16X6X1.2 A.304	WASHER 16X6X1.2 A.304	2	-	4								
15	U960501000	PUERTA LATERAL AD	SIDE DOOR AD	1	-	2								
15	X492803000	PUERTA LATERAL SUS AD	SIDE DOOR AD	-	1	-								
S/Nº	U020537000	CONTRAPUERTA LATERAL G900	SIDE DOOR REVERSE G900	1	-	2								
S/Nº	U020514000	CONTRAPUERTA LATE. SUS AD	SIDE DOOR REVERSE US AD	-	1	-								
	Q412000000	REMACHE TUBULAR 4X8	RIVET 4X8	4	4	8								
16	X960501000	IMAN	MAGNET	2	2	4								
S/Nº	X960502000	FIJACION IMAN	MAGNET ATTACHMENT	2	2	4								
	Q012021000	TORNILLO EXAGONAL M4X10	HEXAGONAL BOLT M4x10	2	2	4								
	Q232020000	ARANDELA A4	WASHER A4	2	2	4								

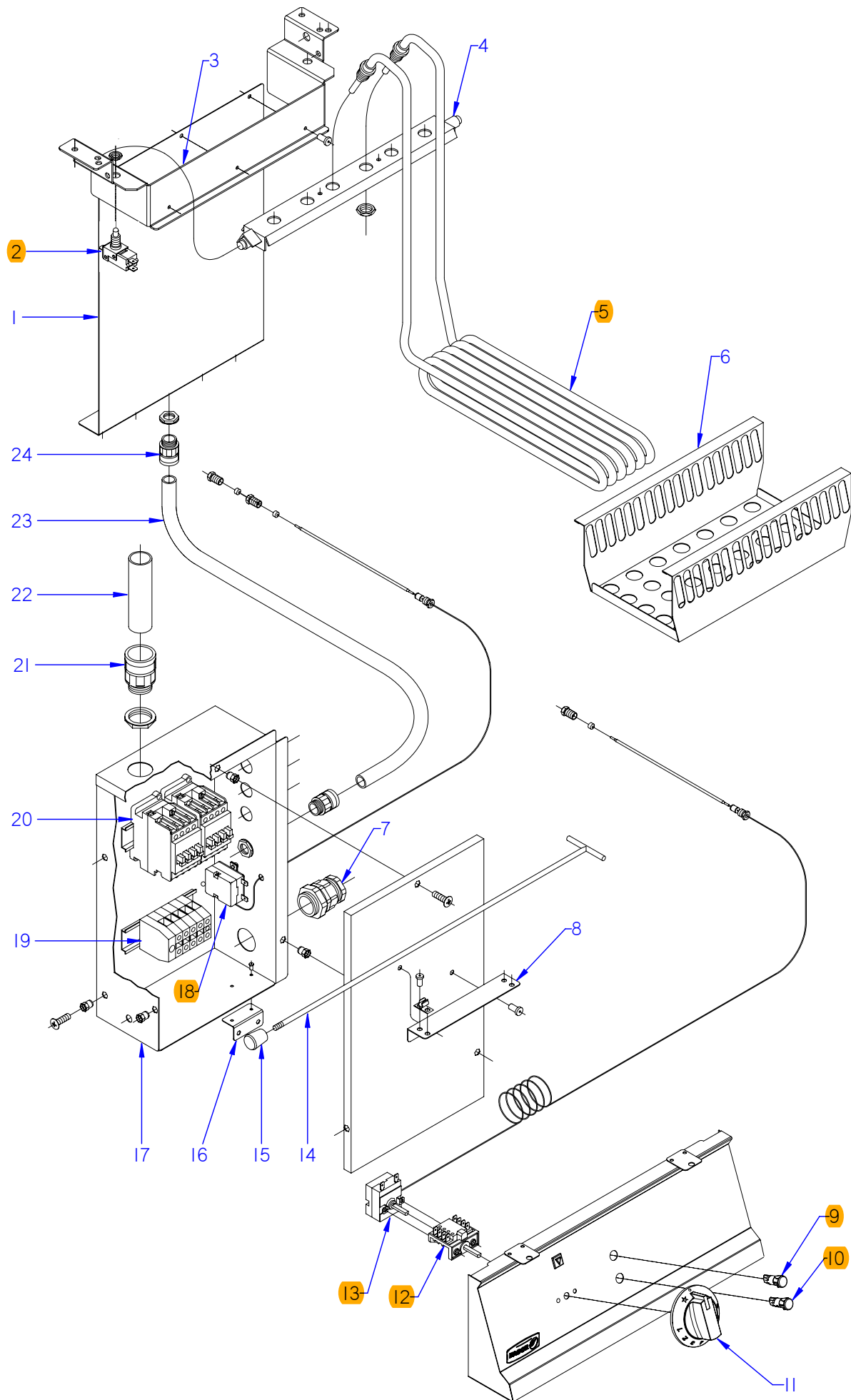

ITEM MARCADO EN COLOR = REPUESTO RECOMENDADO
 COLOURED ITEM = RECOMMENDED SPARE PART

Nº plano / N° plane	Firma	Fecha / Date	Denominación / Denomination: FUNCIONAL ELECTRICO / FUNCTIONAL ELECTRICAL	Lamina / Sheet	Fagor Industrial S.Coop. FAGOR
C-2919	<i>[Signature]</i>	2011-11	FREIDORAS FE9-05 AD / 10 AD	2	Oñate

MOD.		FREIDORAS / FRYERS		ZONA / ZONE		PARTE FUNCIONAL ELECTRICO FUNCTIONAL ELECTRICAL PART						PLANO DIAGRAM		C-2919	
ITEM	CODIGO REFERENCE	DENOMINACION	DENOMINATION	FE9-05 AD	FE9-05 S AD	FE9-10 AD						ELIMINADO ELIMINATED	INTRODUCID. INTRODUCED	NOTAS	
1	X492615000	SUPLEMENTO GUIA CABLES AD	CABLE GUIDE SUPPLEMENT AD	1	1	2									
2	X343015000	MICRORRUPTOR COD.32280001	MICROSWITCH COD.32280001	1	1	2									
	Q306055000	ARANDELA 16x10,3x1	WASHER 16x10.3x1	1	1	2									
3	X492613000	SOPORTE GIRO RESISTENCIAS ad	RESISTOR ROTATION SUPPORT	1	1	2									
4	X182633000	GIRO RESISTENCIAS COMPLETO	COMPLETE RESISTOR ROTATION	1	1	2									
5	X183068000	RESISTENCIA 6 KW	RESISTOR 6 KW	3	3	6									
6	X183023000	CHAPA FIJACION RESISTENCIAS	RESISTOR FASTENING PLATE	1	1	2									
7	R023013000	PRENSA ESTOPAS	STUFFING BOX	1	1	2									
	R023025000	CONTRATUERCA GAES	COUNTERNUT GAES	1	1	2									
	R023026000	JUNTA DE GOMA GAES	RUBBER SEAL GAES	1	1	2									
8	X183054000	ESCUADRA SOPORTE GANCHO	HOOK SUPPORT BRACKET	1	1	2									
	Q419005000	REMACHE 4x8 ALMG3 / ALUMINIO	RIVET 4X8 ALMG3 / ALUMINIUM	2	2	4									
S/Nº	X183055000	PINZA JEBE 6-7	CLIP	2	2	4									
	Q419006000	REM.TUBULAR C/VASTAGO 3,2x10	REM.TUBULAR C/VASTAGO 3,2x10	4	4	8									
9	R693055000	PILOTO VERDE 41227000C7	GREEN PILOT 41227000C7	1	1	2									
10	R693056000	PILOTO AMBAR	AMBAR PILOT	1	1	2									
11	X183064000	BOTON DE MANDO Ø6	CONTROL BUTTON Ø6	1	1	2									
12	X163007000	CONMUTADOR ACOPLE TERMOS.	THERMOSTAT CONNECT SWITCH	1	1	2									
13	X163010000	TERMOSTATO	THERMOSTAT	1	1	2									
14	X183056000	GANCHO SOPOR. RESISTENCIAS	RESISTOR SUPPORT HOOK	1	1	2									
15	X183057000	POMO M6 (ELESA-REF.23901)	KNOB M6 (ELESA-REF.23901)	1	1	2									
16	X183052000	ESC. AMARRE CUADRO ELECTRIC	ELEC. PANEL FASTEN. BRACKET	1	-	1									
	Q419005000	REMACHE 4x8 ALMG3 / ALUMINIO	RIVET 4X8 ALMG3 / ALUMINIUM	2	-	4									
17	X493007000	CUADRO ELECTRICO AD	ELECTRICAL PANEL AD	1	-	2									
17	X493009000	CUADRO ELECTRICO FE9-05 S AD	ELECTRICAL PANEL FE9-05 S AD	-	1	-									
S/Nº	X493006000	TAPA CUADRO ELECTRICO AD	ELECTR. PANEL COVER AD	1	-	2									
S/Nº	X493010000	TAPA CUADRO ELEC. FE9-05 S AD	ELECTR. PANEL COVER AD SUS	-	1	-									
	Q152004000	TORNILLO APLAST, M5x13 A304	FLAT HEADED BOLT M5x13 A304	3	3	6									
18	X163001000	TERMOSTATO LIMITADOR	THERMOSTAT LIMITER	1	1	2									
	Q151320000	TORNILLO ALOMADO M4x6 H,ZINC.	CURVED SCREW M4x6 H,ZINC.	2	2	4									

