

N.º Hoja	Forma	Fecha	Aprobado	Límite	Fabor Industrial S. Depr. Caste	FABOR
C-876		10-00	FREIDORAS ELECTRICAS:4,6,8	1		

MOD.		FREIDORAS ELECTRICAS		ZONA	MUEBLE			PLANO	C-876
ITEM	CODIGO	DENOMINACION	TEXTO	FE-1	FE-6	FE-8			NOTAS
1	X352826	Tapa		1	-	-			
1	X362820	Tapa		-	1	-			
1	X372820	Tapa		-	-	1			
2	X366502	Cestillo (252x130x100)		1	-	(2)*			*La FE-8 puede llevar dos cestillos X366502 como opcion
2	X366502	Cestillo (252x220x100)		-	1	-			
2	X376502	Cestillo (252x280x100)		-	-	1			
3	G152004	Tornillo aplastado M-5x13		1	1	1			
4	G221306	Tuerca exag. autoseguro M-5		1	1	1			
5	9616402	Cacha superior		1	1	1			
6	-	Asa (incluida en cestillo)		1	1	1			
7	G042031	Tornillo avellanado M-5x10		2	2	2			
8	9616401	Cacha inferior		1	1	1			
9	X352812	Encimera frontal		1	-	-			
9	X362803	Encimera frontal		-	1	-			
9	X372803	Encimera frontal		-	-	1			
10	G152004	Tornillo aplastado M-5x13		2	2	2			
11	X352803	Reforzo cuerpo		1	1	1			
12	G419005	Remache tubular Ø 4x8		4	4	4			
13	X352801	Cuerpo exterior		1	-	-			
13	X362801	Cuerpo exterior		-	1	-			
13	X372801	Cuerpo exterior		-	-	1			
14	X352833	Soporte micro izquierdo		1	1	1			
sin	X352831	Soporte micro derecho		1	1	1			
15	G419005	Remache tubular Ø 4x8		10	10	10			
16	Z200105	Pata regulable		4	4	4			
17	G221345	Remache exagonal M-10		4	4	4			
18	X352832	Escuadra pata posterior		2	2	2			
19	X352802	Soporte tapa		2	2	2			
20	G419005	Remache tubular Ø 4x8		2	2	2			

MOD.		FREIDORAS ELECTRICAS		ZONA	MUEBLE			PLANO	C-876
ITEM	CODIGO	DENOMINACION	TEXTO	FE-1	FE-6	FE-8			NOTAS
21	X366101	Cuba de fritura (Gastronom 1/3)		1	-	-			
21	X366101	Cuba de fritura (Gastronom 1/2)		-	1	-			
21	X376101	Cuba de fritura (Gastronom 2/3)		-	-	1			

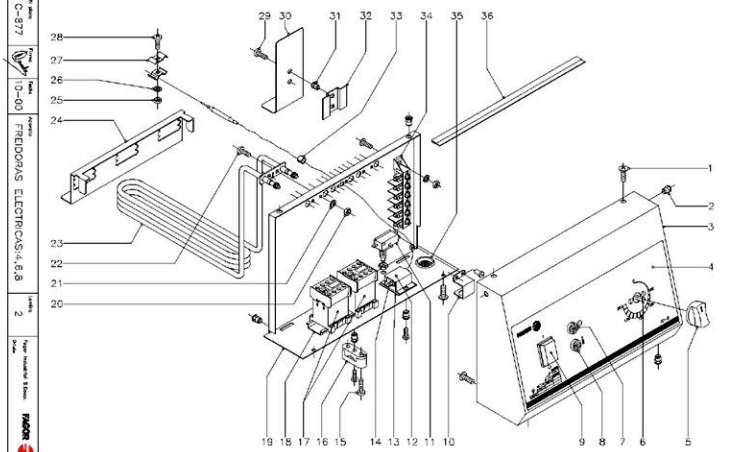

MOD.		FREIDORAS ELECTRICAS		ZONA	PARTE FUNCIONAL ELECTRICA			PLANO	C-877	
ITEM	CODIGO	DENOMINACION	TEXTO	FE-4	FE-6	FE-8				NOTAS
1	Q152004	Tornillo aplastado M-5x13		6	6	6				
2	Q221342	Remache exagonal M-5		6	6	6				
3	X363403	Panel frontal		1	-	-				
3	X363401	Panel frontal		-	-	-				
3	X373401	Panel frontal		-	-	1				
4	X362820	Embelleecedor adhesivo		1	-	-				
4	X362815	Embelleecedor adhesivo		-	-	-				
4	X372815	Embelleecedor adhesivo		-	-	-				
5	R663062	Boton de mando completo Ø66		1	1	1				
6	X033009	Termostato 60 - 200°C.		1	1	1				
6	Z403007	Casquillo distancador		2	2	2				
6	Q041323	Tornillo avellanado M-4x20		2	2	2				
7	Z203004	Piloto verde		1	1	1				(Maquina con corriente)
8	Z203005	Piloto ambar		1	1	1				(Calentamiento)
9	Z653001	Interruptor general		1	1	1				
10	X363020	Soporte microrruptor		1	1	1				
11	Q419005	Remache tubular Ø 4x8		2	2	2				
11	X343015	Microrruptor		1	1	1				
12	Q222005	Tuerca exagonal M-10x0.75		1	1	1				
12	X363007	Soporte termostato de seguridad		1	1	1				
12	Q221341	Remache exagonal M-4		2	2	2				
13	Q032021	Tornillo alomado M-4x10		2	2	2				
13	X363015	Placa aislante		1	1	1				
14	X033001	Termostato de seguridad		1	1	1				
15	Q032036	Tornillo alomado M-5x30		2	2	2				
16	U183029	Brida amarre manguera		1	1	1				
16	Q032021	Tornillo alomado M-4x10		1	1	1				
16	Q221341	Remache exagonal M-4		1	1	1				
17	F463023	Contacto (220/380 V)		-	-	2				
18	R663056	Guia contacto L=120		-	-	1				
18	Q419005	Remache tubular Ø 4x8		-	-	2				
19	X363004	Cuadro electrico		1	-	-				
19	X363004	Cuadro electrico		-	-	1				
19	X373004	Cuadro electrico		-	-	1				
20	Q162020	Tuerca exagonal M-4		2	6	6				
21	Q242020	Arandela abanico A-4		2	6	6				
22	Q032021	Tornillo alomado M-4x10		2	6	6				
23	X363024	Resistencia 3000 W., 250V.		1	-	-				
23	X363023	Resistencia 1500 W., 250/380 V.		-	3	-				
23	X373022	Resistencia 2000 W., 250/380 V.		-	-	3				
24	X363030	Separador de resistencias		1	-	-				
24	X363030	Separador de resistencias		-	-	1				
24	X373030	Separador de resistencias		-	-	1				
25	Q162020	Tuerca exagonal M-4		2	6	6				
26	Q242020	Arandela abanico A-4		2	6	6				
27	X033011	Brida sujecion bulbo		4	4	4				
28	Q032021	Tornillo alomado M-4x10		2	2	2				
29	Q032021	Tornillo alomado M-4x10		2	2	2				
30	X363008	Protector de resistencias		1	-	-				
31	Q221341	Remache exagonal M-4		2	2	2				
32	X363010	Amarre protector		1	-	-				
33	X033014	Anillo amarre capilar		4	4	4				
34	U183046	Regleta auxiliar		1	-	-				
34	R263044	Regleta auxiliar		-	-	1				
35	X723014	Pasamuros Ø 30		1	1	1				
36	3703500	Perfil goma en "Y" 16x3x150		1	-	-				
36	3703500	Perfil goma en "Y" 16x3x240		-	-	-				
36	3703500	Perfil goma en "Y" 16x3x330		-	-	1				

MOD.		FREIDORAS ELECTRICAS		ZONA	VARIOS				PLANO	
ITEM	CODIGO	DENOMINACION	TEXTO	FE-4	FE-6, FC-8 FA-7, TF-7	FE-8, FC-8 FA-7, TF-7	FE-8, FC-8 FA-9, TF-9			NOTAS
	X-356503	Folleto de instrucciones		1	1	1				

MOD.		FREIDORAS ELECTRICAS		ZONA	VERSION : 220 V. (III) Y 380/415 V. (III N) ; 50/60 Hz.				PLANO	
ITEM	CODIGO	DENOMINACION	TEXTO	FE-6, FC-6 FA-7, TF-7	FE-8, FC-8 FA-7, TF-7	FE-8, FC-8 FA-9, TF-9				NOTAS
	X363016	Cable de alimentacion 5x1,6		1	-	-				
	X363017	Cable de alimentacion 5x2,5		-	-	-				
	X373007	Cableado portamandos		1	1	1				
	X373008	Cableado regleta a contactor		-	-	1				
	X373009	Cableado contactor a resistencia		-	-	1				
	X363015	Esquema electrico adhesivo		1	1					(Plano HC-14145-3)

MOD.		FREIDORAS ELECTRICAS		ZONA	VERSION : 220/240 V. (I N) ; 50/60 Hz.				PLANO	
ITEM	CODIGO	DENOMINACION	TEXTO	FE-4	FE-6, FC-6 FA-7, TF-7	FE-8, FC-8 FA-9, TF-9				NOTAS
	Z660341	Cable de alimentacion 3x1,6		1	-	-				
	X363018	Cable de alimentacion 3x2,5		-	-	-				
	X363019	Cable de alimentacion 3x4		-	-	-				
	X363009	Cableado portamandos		1	1	1				
	X373007	Cableado portamandos		-	-	1				
	X373008	Cableado regleta a contactor		-	-	1				
	X373009	Cableado contactor a resistencias		-	-	1				
	X363013	Esquema electrico adhesivo		1	-	-				(Plano HB-13812-2)
	X363015	Esquema electrico adhesivo		-	-	1				(Plano HC-14145-3)

MOD.		FREIDORAS ELECTRICAS CORECO		ZONA	PIEZAS ESPECIFICAS		PLANO	C-877	
ITEM	CODIGO	DENOMINACION	TEXTO	FC-6	FC-8				
	X362835	Embelleecedor adhesivo		1	-				
	X372835	Embelleecedor adhesivo		-	1				

MOD.		FREIDORAS ELECTRICAS AZKOYEN		ZONA	PIEZAS ESPECIFICAS		PLANO	C-877	
ITEM	CODIGO	DENOMINACION	TEXTO	FA-7	FA-9				
	X363400	Embelleecedor adhesivo		1	-				
	X373400	Embelleecedor adhesivo		-	1				
	Z668813	Boton de mando completo Ø66		1	1				
s/n	Z668807	Indicador		1	1				
s/n	X363016	Casquillo distancador		2	2				
s/n	Q042022	Tornillo avellanado M-4x15		2	2				
s/n	X363401	Embelleecedor tapa		1	1				

MOD.		FREIDORAS ELECTRICAS EDESA		ZONA	PIEZAS ESPECIFICAS		PLANO	C-877	
ITEM	CODIGO	DENOMINACION	TEXTO	TF-7	TF-9				
	X362830	Embelleecedor adhesivo		1	-				
	X372830	Embelleecedor adhesivo		-	1				