

- Fry-Tops a gas con horno
- Grillades à gaz avec four
- Gas Fry-Tops with oven
- Gas Griddleplatten mit ofen

Mod.

FTG9-11 L

FTG9-11 R

FTG9-11 CL

FTG9-11 CR

ENERO 2000

FAGOR



Fagor Industrial, S. Coop.

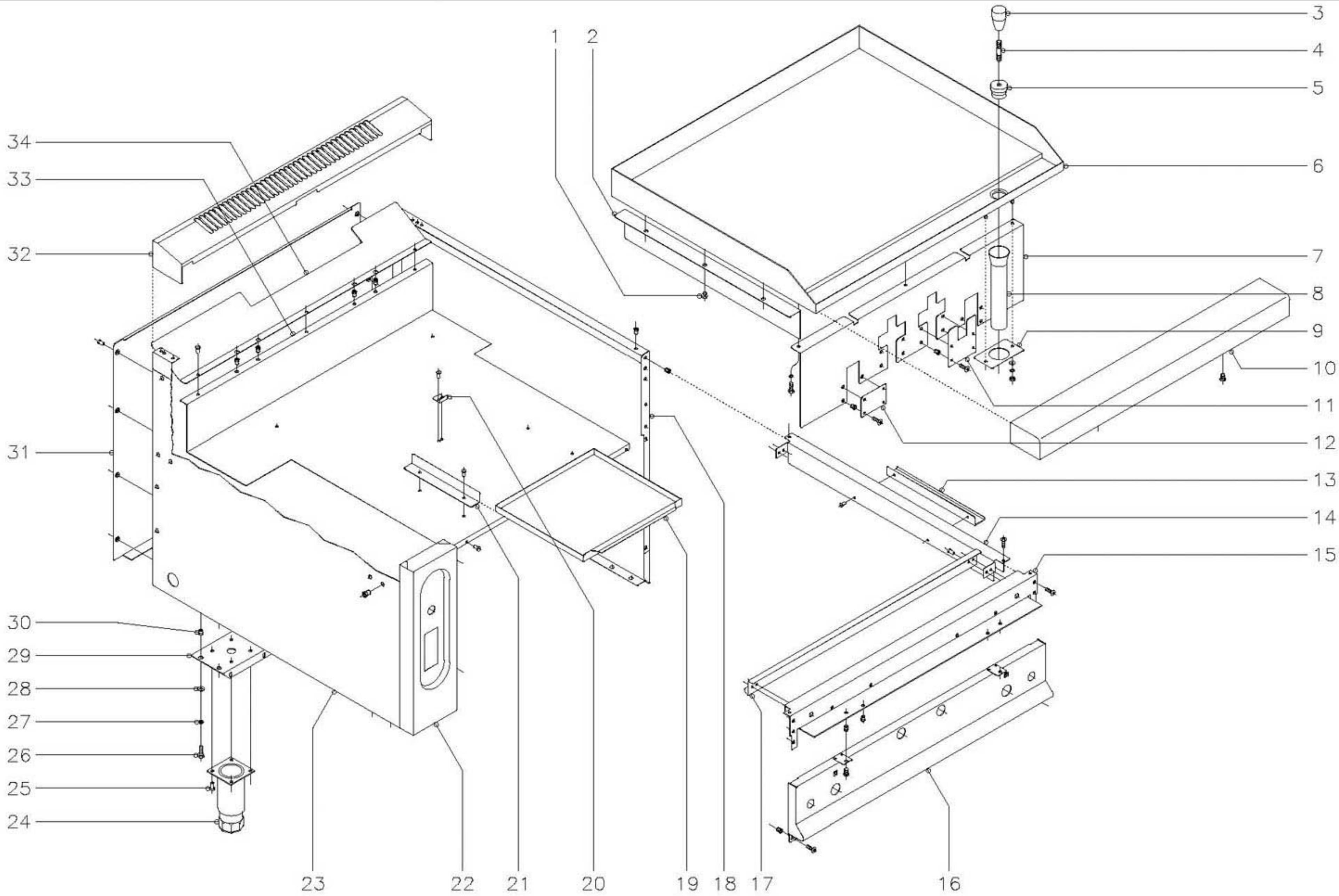

N plano C-768	Firma <i>[Signature]</i>	Fecha 1-00	Aparato FRYTOP + HORNO FTG9-11	Lamina 1	Fagor Industrial S.Coop. FAGOR 
------------------	-----------------------------	---------------	-----------------------------------	-------------	---

MOD.

FRYTOP + HORNO

ZONA

MUEBLE

PLANO

C-768

ITEM	CODIGO	DENOMINACION	TEXTO	FTG9-11									NOTAS
1	R165414	Apoyo lateral		6									
2	R152611	Liston lateral		2									
3	S116122	Mando pomo		1									(SOLO CROMODURO)
4	R619913	Alargadera		1									(SOLO CROMODURO)
5	R619912	Tapon rebosadero		1									(SOLO CROMODURO)
6	R165437	Plancha lisa		1									
6	R165443	Plancha lisa cromoduro		1									
6	R165446	Plancha rayada		1									
6	R165447	Plancha rayada cromoduro		1									
6	R165444	Plancha lisa + rayada		1									
6	R165441	Plancha lisa + rayada cromoduro		1									
7	R602605	Liston cubierta grifos		1									
	Q262040	Arandela muelle A-6		3									
	Q012042	Tornillo exagonal M-6x15		3									
8	R155010	Tubo desagüe		1									
9	R152607	Soporte tubo desagüe		1									
	Q302022	Arandela plana Ø16xØ6x1,2		2									
	Q262040	Arandela muelle A-6		2									
	Q162040	Tuerca exagonal M-6		2									
10	R165431	Anterior de mesa 1 M.		1									
	Q221342	Remache exagonal M-5		2									
	Q152004	Tornillo aplastado M-5x13		2									
11	R602602	Protector grifo		2									
	Q221342	Remache exagonal M-5		8									
	Q152004	Tornillo aplastado M-5x13		8									
12	R602604	Protector inferior		1									
	Q221342	Remache exagonal M-5		3									
	Q152004	Tornillo aplastado M-5x13		3									

MOD.

FRITOP + HORNO

ZONA

MUEBLE

PLANO

C-768

ITEM	CODIGO	DENOMINACION	TEXTO	FTG9-11																NOTAS
13	R152601	Tirante lateral		2																
	Q419005	Remache tubular Ø4x8		4																
14	R152807	Lateral de mesa		2																
	Q152004	Tornillo aplastado M-5x13		4																
	Q221342	Remache exagonal M-5		4																
15	R162613	Escuadra amarre anterior mesa		1																
	Q152004	Tornillo aplastado M-5x13		6																
	Q221342	Remache exagonal M-5		6																
16	R602801	Panel portamandos		1																
	Q152004	Tornillo aplastado M-5x13		4																
	Q221342	Remache exagonal M-5		4																
17	R602606	Anterior interior de mesa		1																
	Q419005	Remache tubular Ø4x8		4																
18	U562852	Panel lateral derecho		1																
19	R602600	Bandeja recoge grasas		1																
20	R202607	Escuadra tope recoge grasas		1																
	Q419005	Remache tubular Ø4x8		2																
21	R612702	Guia recoge grasas		2																
	Q419005	Remache tubular Ø4x8		4																
22	U562854	Portamandos lateral		1																
	Q152004	Tornillo aplastado M-5x13		2																
23	X162810	Panel lateral izquierdo		1																
24	X260150	Pata regulable		4																
25	Q411304	Remache avibulb Ø4,8		16																
26	Q012043	Tornillo exagonal M-6x20		8																
27	Q262040	Arandela muelle A-6		8																
28	Q302022	Arandela plana Ø16xØ6x1,2		8																
29	X172601	Liston soporte patas 1 M.		2																
30	Q221343	Remache exagonal M-6		8																

ITEM	CODIGO	DENOMINACION	TEXTO	FTG9-11										NOTAS
31	U562853	Panel posterior		1										
	Q419005	Remache tubular Ø4x8		8										
32	R165432	Embellecedor bajo 1 M.		1										
33	R602603	Base inferior		1										
	Q419005	Remache tubular Ø4x8		3										
	Q152004	Tornillo aplastado M-5x13		2										
	Q221304	Remache redondo M-5		2										
34	R602607	Salida de humos		1										
	Q419005	Remache tubular Ø4x8		3										

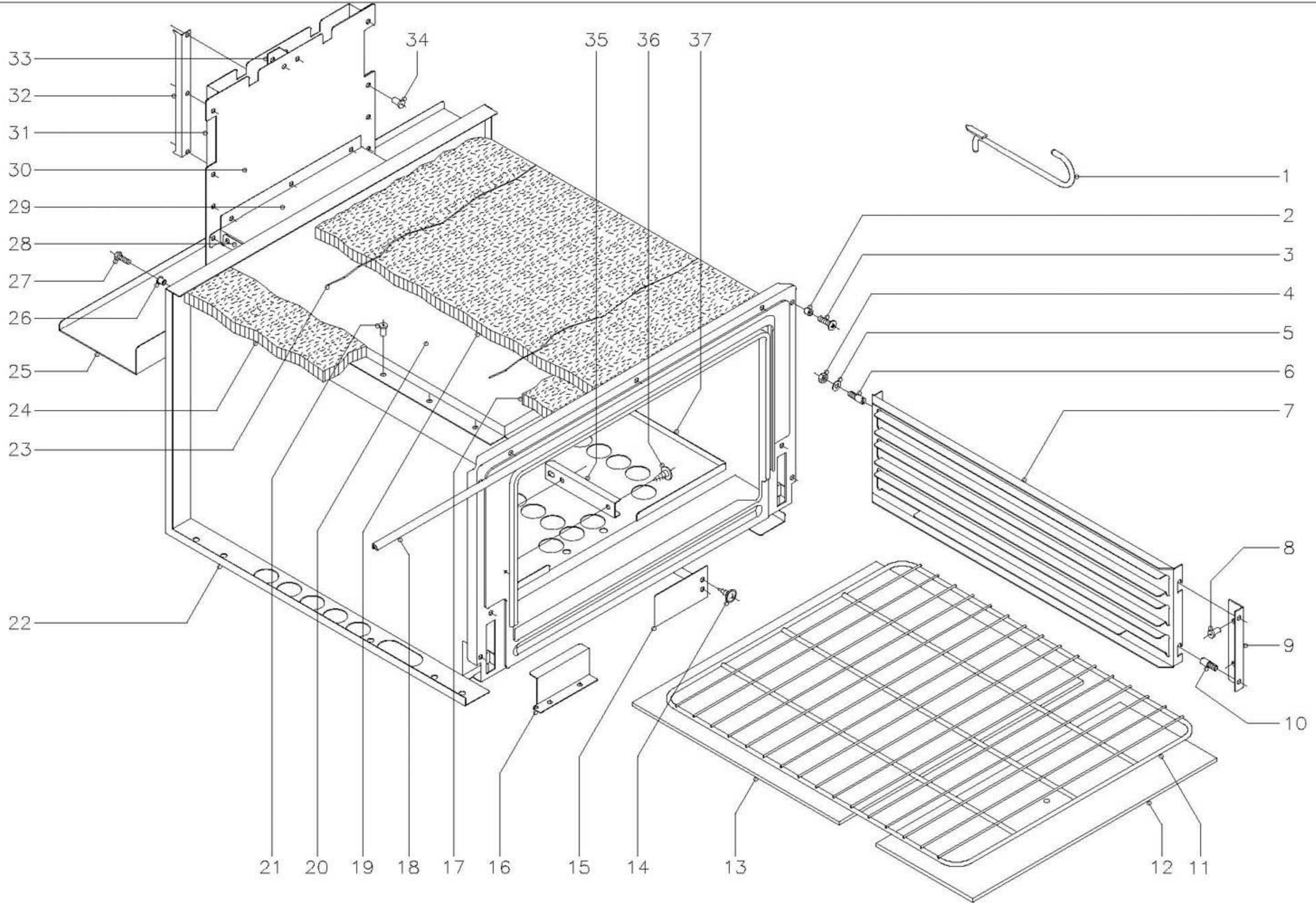

N plano	Firma	Fecha	Aparato	Lamina	Fagor Industrial S.Coop.	FAGOR 
C-769		1-00	FRYTOP + HORNO FTG9-11	2	0<ate	

MOD.

FRYTOP + HORNO

ZONA

HORNO

PLANO

C-769

ITEM	CODIGO	DENOMINACION	TEXTO	FTG9-11																NOTAS
1	0623600	Palanca levantaplacas		1																
2	Q221304	Remache redondo M-5		4																
3	Q152004	Tornillo aplastado M-5x13		4																
4	Q162040	Tuerca exagonal M-6		4																
5	Q302022	Arandela plana Ø16xØ6x1,2		4																
6	Q151336	Tornillo soporte guias		4																
7	U325608	Guia de bandejas		2																
8	Q419005	Remache tubular Ø4x8		4																
9	U325611	Escuadra soporte guia bandejas		2																
10	Q151336	Tornillo soporte guias		4																
11	U135635	Parrilla de horno		1																
12	U745630	Cabeza placa de horno		1																
13	U745631	Placa de horno		1																
14	Q151401	Tornillo alomado		2																
15	U325618	Tapa salida humos		1																
16	U742610	Protector quemador horno		1																
17	U745610	Vitrofib 390x70x20		1																
18	U745626	Junta puerta horno		1																
19	U325621	Vitrofib 1455x670x20		1																
20	U745613	Camara conduccion de humos		1																
21	Q419005	Remache tubular Ø4x8		17																
22	U745620	Cuerpo de horno		1																
23	-	Alambre amarre aislante		2																
24	R660530	Vitrofib 680x95x20		2																
25	U562656	Evacuacion calor mesa		1																
26	Q221321	Remache redondo M-6		2																
27	Q012043	Tornillo exagonal M-6x20		2																
28	U565610	Union chimenea inferior		1																
29	U565609	Union chimenea superior		1																

MOD.

FRYTOP + HORNO

ZONA

HORNO

PLANO

C-769

ITEM	CODIGO	DENOMINACION	TEXTO	FTG9-11									NOTAS
30	U745605	Anterior de chimenea		1									
31	U745606	Posterior de chimenea		1									
32	U565611	Distanciador de chimenea a panel		1									
33	U745607	Distanciador de chimenea		1									
34	Q419005	Remache tubular Ø4x8		18									
35	U055644	Conjunto fijacion bulbo		1									
36	Q151401	Tornillo alomado		2									
37	U565608	Base de horno		1									

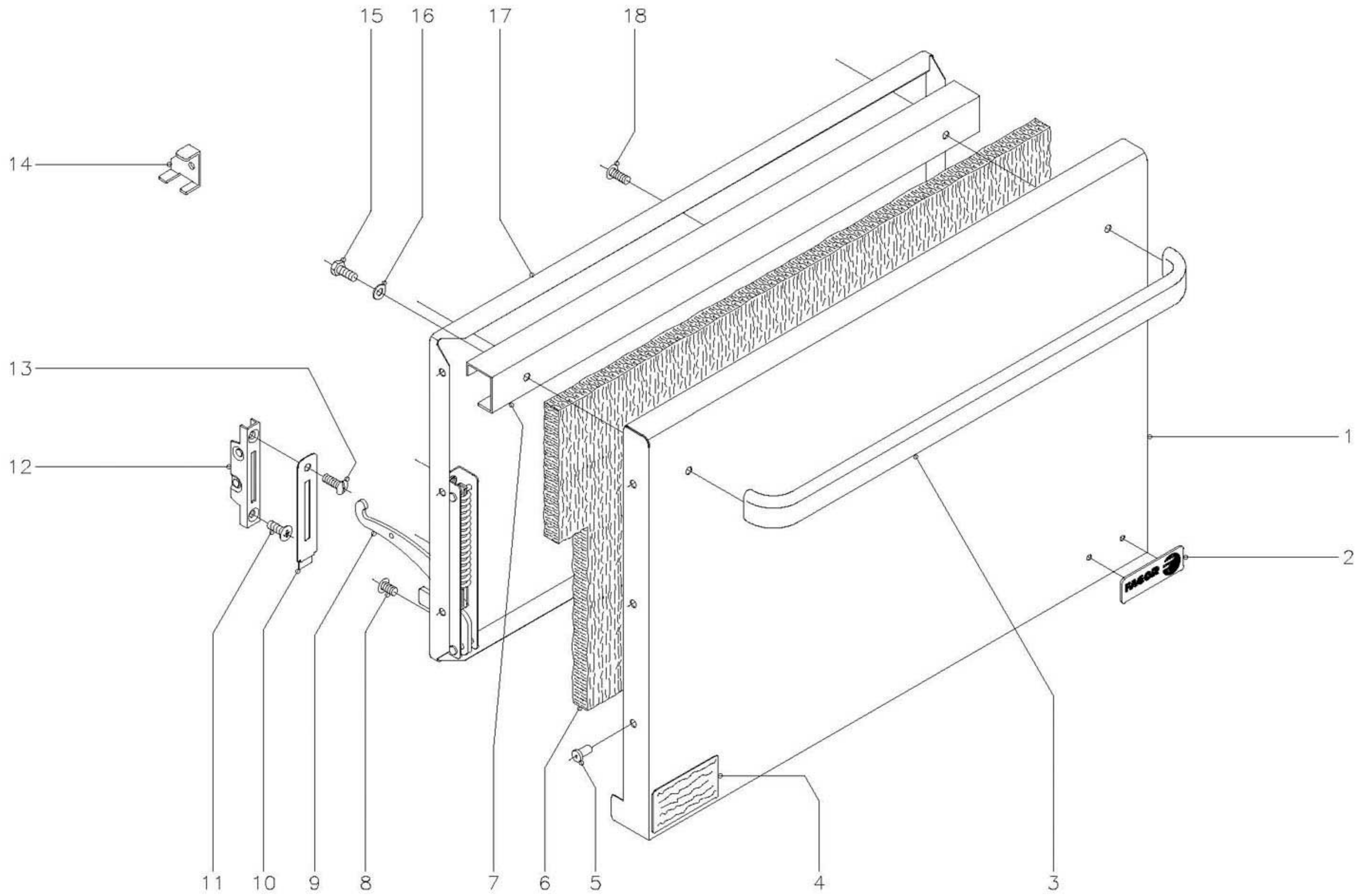

N plano	Firma	Fecha	Aparato	Lamina	Fagor Industrial S.Coop.	FAGOR 
C-770		1-00	FRYTOP + HORNO FTG9-11	3	Ocate	

MOD.

FRYTOP + HORNO

ZONA

PUERTA

PLANO

C-770

ITEM	CODIGO	DENOMINACION	TEXTO	FTG9-11																NOTAS
1	U740501	Puerta de horno		1																
2	U262806	Escudo FAGOR		1																
	Q221023	Clips sujecion escudo		2																
3	U580520	Asa puerta horno		1																
4	S326530	Placa matricula		1																
5	Q419005	Remache tubular Ø4x8		6																
6	U260502	Aislante vitrofib 680x380x20		1																
7	U320507	Refuerzo de puerta		1																
8	Q152022	Tornillo amarre M-6x8		6																
9	U010511	Bisagra izquierda		1																
s/n	U010504	Bisagra derecha		1																
10	U010510	Embellecedor guia bisagra		2																
11	Q042043	Tornillo avellanado M-6x20		2																
12	U010512	Guia de bisagra		2																
13	Q152017	Tornillo amarre M-6x13		2																
14	U746501	Escuadra montaje puerta		2																
15	Q012041	Tornillo exagonal M-6x10		2																
16	Q302022	Arandela plana Ø16xØ6x1,2		2																
17	U260501	Contrapuerta de horno		1																
18	Q152017	Tornillo amarre M-6x13		3																

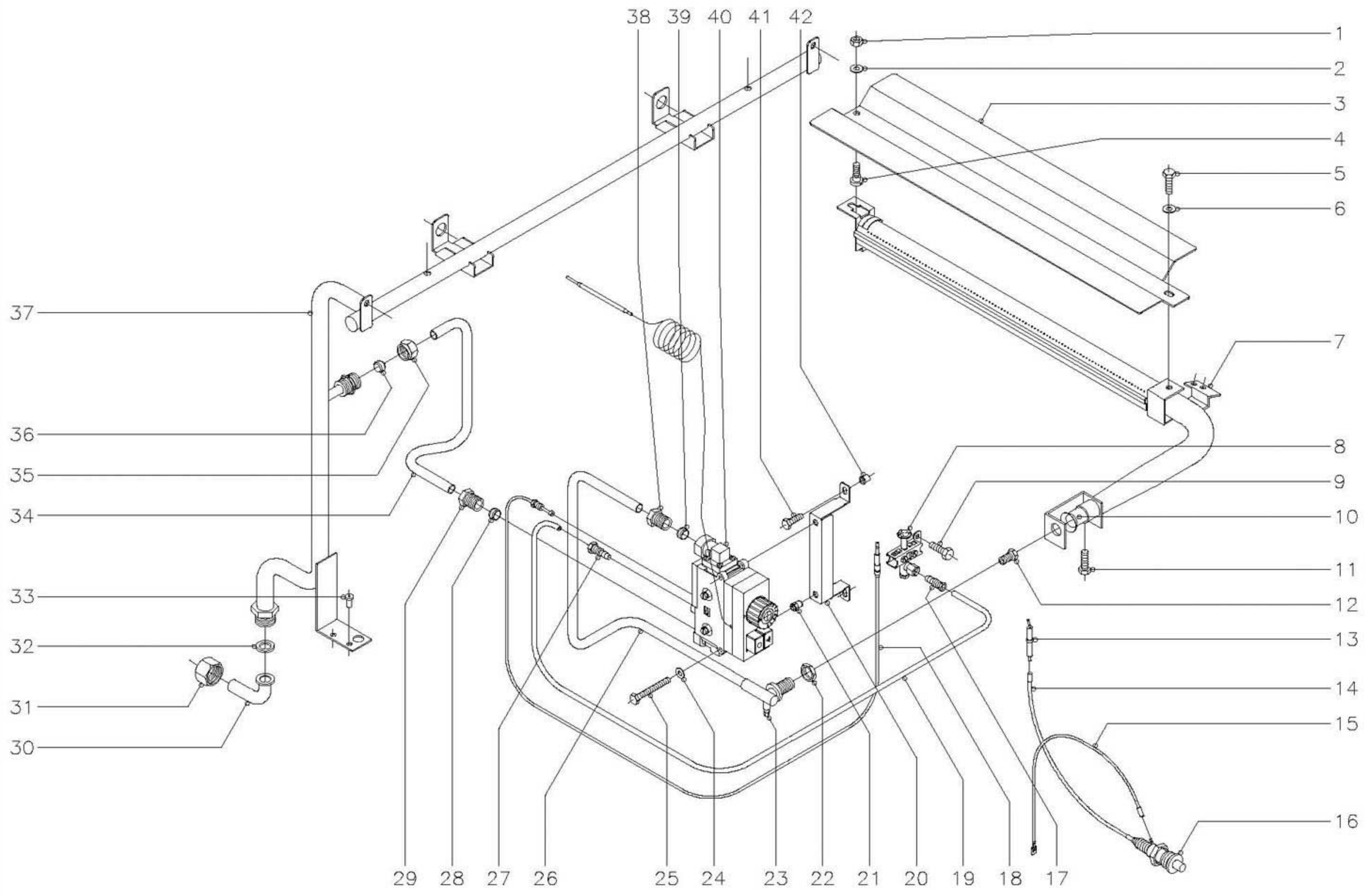

N plano	Firma	Fecha	Aparato	Lamina	Fagor Industrial S.Coop.	FAGOR
C-771	<i>[Signature]</i>	1-00	FRYTOP + HORNO FTG9-11	4	Dcate	

MOD.

FRYTOP + HORNO

ZONA

PARTE FUNCIONAL HORNO

PLANO

C-771

ITEM	CODIGO	DENOMINACION	TEXTO	FTG9-11																		NOTAS
1	Q162040	Tuerca exagonal M-6		1																		
2	Q302022	Arandela plana Ø16xØ6x1,2		1																		
3	U745705	Difusor quemador horno		1																		
4	R252624	Piton soporte		1																		
5	Q012041	Tornillo exagonal M-6x10		1																		
6	Q302022	Arandela plana Ø16xØ6x1,2		1																		
7	U745700	Quemador de horno		1																		
8	U322118	Piloto completo		1																		
9	Q012031	Tornillo exagonal M-5x10		2																		
10	U325707	Regulador de aire		1																		
11	Q012031	Tornillo exagonal M-5x10		1																		
12	U052401	Tobera Ø1,45 (B.P.) Horno		1																		
12	1011600	Tobera Ø2,25 (G.N.) Horno		1																		
12	9424600	Tobera Ø4,23 (G.V.) Horno		1																		
13	X012101	Bujia de encendido		1																		
14	U323030	Cable bujia a piezoelectrico		1																		
15	U333003	Cable masa a piezoelectrico		1																		
16	S113034	Piezoelectrico		1																		
17	U134323	Racord con bicono Ø6		1																		
18	U562130	Termopar L=850		1																		
19	U565036	Conduccion a piloto de horno		1																		
20	U565620	Soporte valvula minisit		1																		
21	Q221343	Remache exagonal M-6		2																		
22	Q223019	Tuerca exagonal 3/8"		1																		
23	Q153002	Tornillo toma presion		1																		
24	Q302022	Arandela plana Ø16xØ6x1,2		2																		
25	Q011348	Tornillo exagonal M-6x60		2																		
26	U565024	Conduccion a quemador horno		1																		
27	U134323	Racord con bicono Ø6		1																		

MOD.

FRYTOP+ HORNO

ZONA

PARTE FUNCIONAL HORNO

PLANO

C-771

ITEM	CODIGO	DENOMINACION	TEXTO	FTG9-11																NOTAS
28	U055043	Bicono Ø12		1																
29	U264310	Manguito 3/8"		1																
30	U565007	Codo entrada gas		1																
31	U725006	Tuerca 3/4"		1																
32	Q306052	Arandela junta Ø23xØ15x2,5		1																
33	Q411304	Remache avibulb Ø4,8		2																
34	U565023	Tubo entrada a valvula		1																
35	Q221334	Tuerca 1/2"		1																
36	U055043	Bicono Ø12		1																
37	R605000	Conduccion general (B.P.y G.N.)		1																
38	U264310	Manguito 3/8"		1																
39	U055043	Bicono Ø12		1																
40	U264315	Valvula minisit completa		1																
	U134316	Cuerpo valvula		1																
	U134317	Boton de mando		1																
	U134318	Cubierta		1																
	U264300	Racord 3/8"		2																
	Q031322	Tornillo alomado M-4x15		8																
	Q307041	Junta torica Ø25,4xØ20,2xØ2,6		2																
	U264398	Bulbo termostato horno		1																
	U264399	Grupo electromagnetico		1																
41	Q012032	Tornillo exagonal M-5x15		2																
42	Q221304	Remache redondo M-5		2																

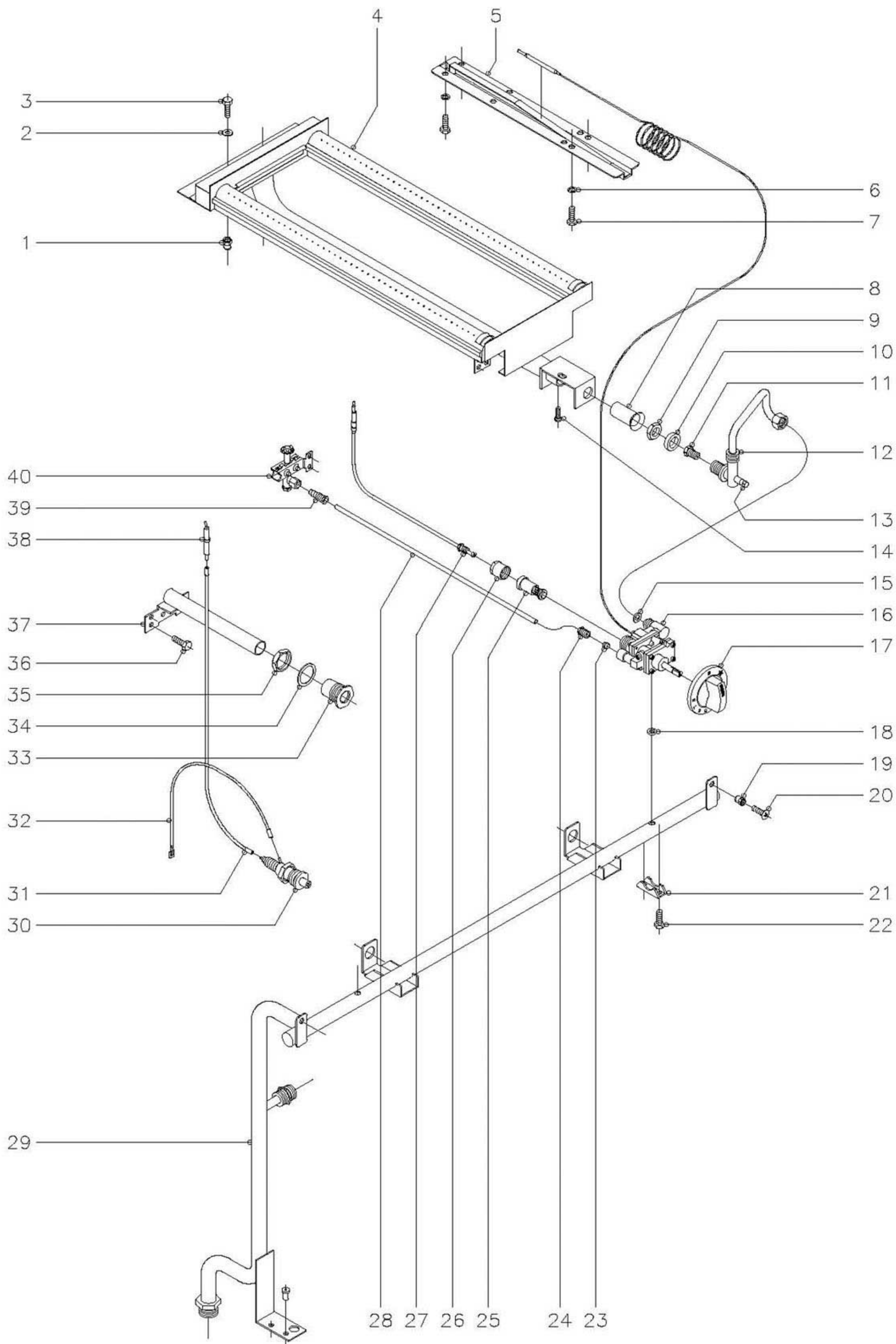

N plano
C-772

Firma
[Signature]

Fecha
1-00

Aparato (B.P.; G.N.)
FRYTOP + HORNO FTG9-11

Lamina
5

Fagor Industrial S.Coop.
Ocate



MOD.

FRYTOP + HORNO

ZONA

PARTE FUNCIONAL FRYTOP (B.P.y G.N.)

PLANO

C-772

ITEM	CODIGO	DENOMINACION	TEXTO	FTG9-11															NOTAS
1	Q221342	Remache exagonal M-5		4															
2	Q302022	Arandela plana Ø16xØ6x1,2		4															
3	Q012031	Tornillo exagonal M-5x10		4															
4	R635700	Quemador frytop		2															
5	R162630	Conjunto soporte bulbo		2															
6	Q242030	Arandela muelle A-5		8															
7	Q012032	Tornillo exagonal M-5x15		8															
8	U325707	Regulador de aire		2															
9	Q223019	Tuerca exagonal 3/8"		2															
10	Q301323	Arandela Ø25xØ17x6		2															
11	9105100	Tobera Ø1,50 (Butano-Propano)		2															
11	U052401	Tobera Ø1,45 (Butano-Propano)		2															(VERSION CROMODURO)
11	1011600	Tobera Ø2,25 (Gas Natural)		2															
11	U262400	Tobera Ø2,15 (Gas Natural)		2															(VERSION CROMODURO)
12	R605008	Conduccion a quemador derecho		1															
s/n	R605003	Conduccion a quemador izquierdo		1															
13	Q153002	Tornillo toma presion		2															
14	Q012042	Tornillo exagonal M-6x15		2															
15	Q306026	Arandela junta Ø14xØ8,5x1,5		2															
16	R612101	Termostato MTZ-7200 (120-310°C)		2															
17	R202103	Boton de mando Ø 8		2															
18	Q307034	Junta de estanqueidad termostato		2															
19	Q221342	Remache exagonal M-5		2															
20	Q152004	Tornillo aplastado M-5x13		2															
21	Z982018	Brida amarre termostato		2															
22	Q151317	Tornillo exagonal M-5x22		4															
23	X205028	Bicono Ø 6		2															
24	U195009	Manguito empalme		2															
25	6002705	Grupo electromagnetico		2															

MOD.

FRYTOP + HORNO

ZONA

PARTE FUNCIONAL FRYTOP (B.P.y G.N.)

PLANO

C-772

ITEM	CODIGO	DENOMINACION	TEXTO	FTG9-11															NOTAS
26	6002706	Tapon grupo electromagnetico		2															
27	U222100	Termopar L=500		2															
28	R605010	Conduccion a piloto derecho		1															
s/n	R605007	Conduccion a piloto izquierdo		1															
29	R605000	Conduccion general (B.P.y G.N.)		1															
30	S113034	Piezoelctrico		2															
31	R613030	Cable bujia a piezoelctrico		2															
32	U333003	Cable masa a piezoelctrico		2															
33	S112804	Embellecedor tubo encendido		2															
34	Q306027	Arandela junta Ø33,8xØ27x1,5		2															
35	Q221324	Tuerca exagonal 3/4"		2															
36	Q012031	Tornillo exagonal M-5x10		4															
37	R165011	Tubo de encendido		2															
38	X012101	Bujia de encendido		2															
39	U134323	Racord con bicono Ø 6		2															
40	U322118	Piloto completo		2															

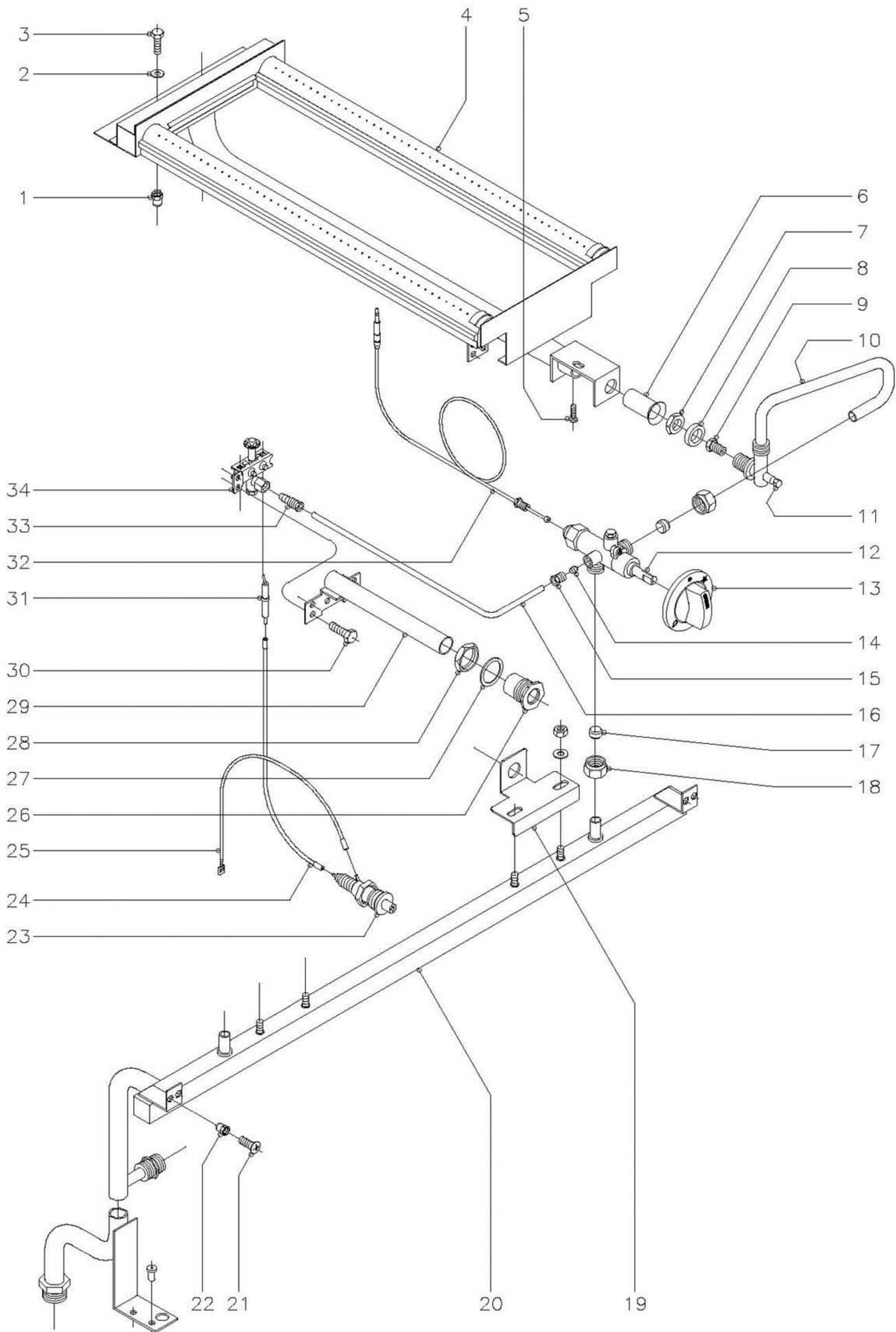

MOD.

FRYTOP + HORNO

ZONA

PARTE FUNCIONAL FRYTOP (GAS VILLA)

PLANO

C-773

ITEM	CODIGO	DENOMINACION	TEXTO	FTG9-11															NOTAS
1	Q221342	Remache exagonal M-5		4															
2	Q302022	Arandela plana Ø16xØ6x1,2		4															
3	Q012031	Tornillo exagonal M-5x10		4															
4	R635700	Quemador frytop		2															
5	Q012042	Tornillo exagonal M-6x15		2															
6	U325707	Regulador de aire		2															
7	Q223019	Tuerca exagonal 3/8"		2															
8	Q301323	Arandela Ø 25xØ17x6		2															
9	X102403	Tobera Ø 4,58 (Gas Villa)		2															(NO HAY VERSION CROMODURO)
10	R605011	Conduccion a quemador derecho		1															
s/n	R605013	Conduccion a quemador izquierdo		1															
11	Q153002	Tornillo toma presion		2															
12	R612100	Grifo CAL-3200 (min. 0,8)		2															
13	U542100	Boton de mando Ø 10		2															
14	X205028	Bicono Ø 6		2															
15	U195009	Manguito empalme		2															
16	R605015	Conduccion a piloto derecho		1															
s/n	R605016	Conduccion a piloto izquierdo		1															
17	U055043	Bicono Ø 12		4															
18	Q221336	Tuerca M-18x1,5		4															
19	U845007	Escuadra amarre quemador		2															
	Q302022	Arandela plana Ø16xØ6x1,2		4															
	Q162040	Tuerca exagonal M-6		4															
20	R605005	Tubo distribuidor gen.(GAS VILLA)		1															
21	Q152004	Tornillo aplastado M-5x13		2															
22	Q221342	Remache exagonal M-5		2															
23	S113034	Piezoeléctrico		2															
24	R613030	Cable bujia a piezoeléctrico		2															
25	U333003	Cable masa a piezoeléctrico		2															

MOD.

FRITOP + HORNO

ZONA

PARTE FUNCIONAL FRYTOP (GAS VILLA)

PLANO

C-773

ITEM	CODIGO	DENOMINACION	TEXTO	FTG9-11													NOTAS
26	S112804	Embellecedor tubo encendido		2													
27	Q306027	Arandela junta Ø33,8xØ27x1,5		2													
28	Q221324	Tuerca exagonal 3/4"		2													
29	R165011	Tubo de encendido		2													
30	Q012031	Tornillo exagonal M-5x10		4													
31	X012101	Bujia de encendido		2													
32	U222100	Termopar L=500		2													
33	U134323	Racord con bicono Ø 6		2													
34	U322118	Piloto completo		2													

MOD.

FRYTOP + HORNO

ZONA

VARIOS

PLANO

ITEM	CODIGO	DENOMINACION	TEXTO	FTG9-11																NOTAS
	R606500	Folleto de instrucciones		1																

MOD.		FRYTOP + HORNO		ZONA	PIEZAS ESPECIFICAS PARA LOS DISTINTOS GASES							PLANO	C-771 C-772 C-773	
ITEM	CODIGO	DENOMINACION	TEXTO	FTG9-11									NOTAS	
		<u>BUTANO - PROPANO</u>												
12	U052401	Tobera Ø 1,45 (Horno)		1									(C-771)	
11	9105100	Tobera Ø 1,50 (Frytop)		2									(C-772)	
11	U052401	Tobera Ø 1,45 (Frytop)		2									(C-772) VERSION CROMODURO	
s/n	U136501	Indicador (But. Pro.)		1										
		<u>GAS NATURAL</u>												
12	1011600	Tobera Ø 2,25 (Horno)		1									(C-771)	
11	1011600	Tobera Ø 2,25 (Frytop)		2									(C-772)	
11	U262400	Tobera Ø 2,15 (Frytop)		2									(C-772) VERSION CROMODURO	
s/n	U134402	Indicador (Gas Natural)		1										
		<u>GAS VILLA</u>												
12	9424600	Tobera Ø 4,23 (Horno)		1									(C-771)	
9	X102403	Tobera Ø 4,58 (Frytop)		2									(C-773)	
		NO HAY VERSION CROMODURO												
s/n	U134310	Indicador (Gas Villa)		1										