

**Frytop
Fry-Tops
Grillades
Griddleplatten
Frytop**

Gama 700

Modelos:

FTG-705

FTG-710

FTE-705

FTE-710



Diciembre 2002 December

FAGOR

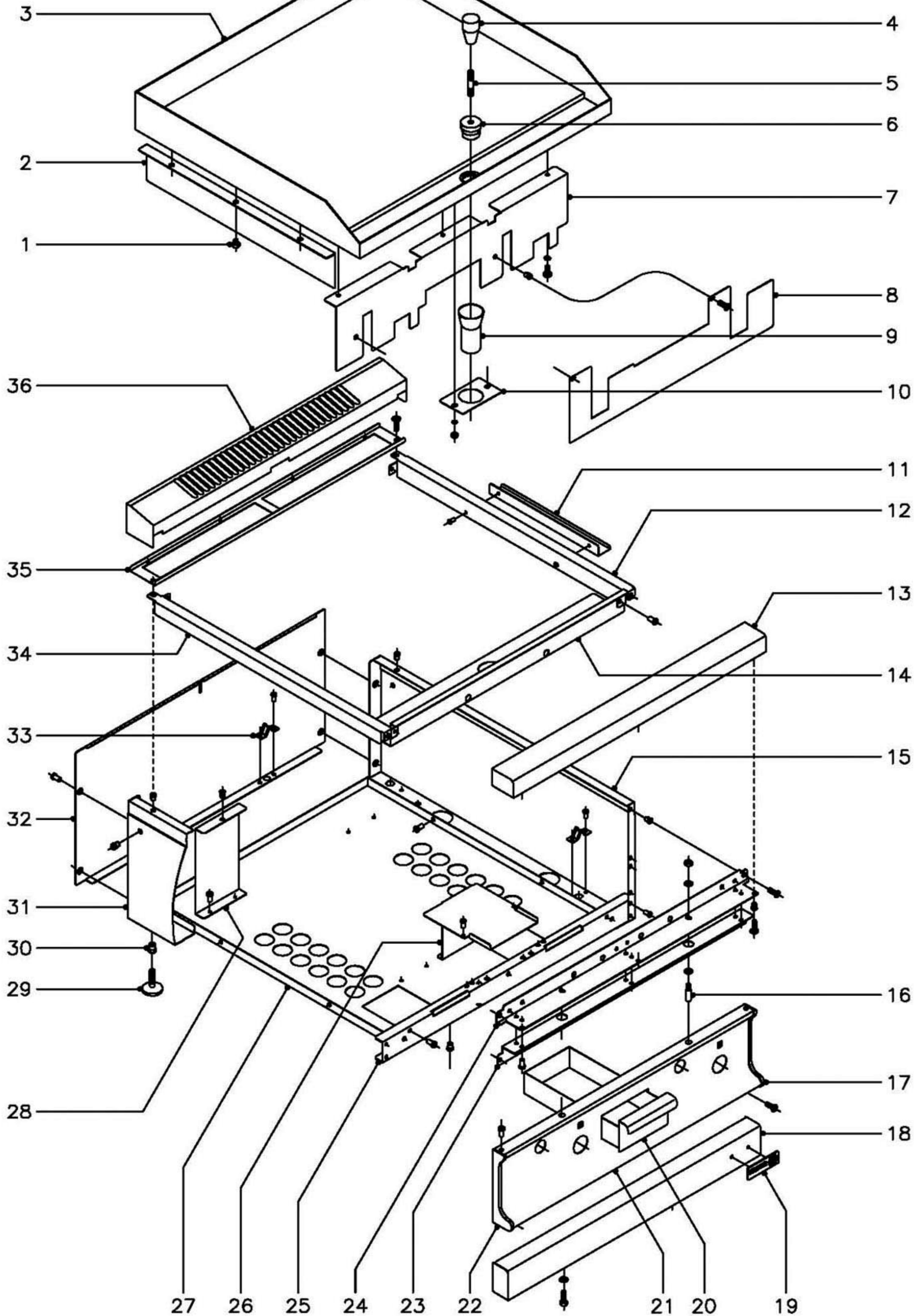

Fagor Industrial



N plano C-1250	Firma 	Fecha 12-2002	Aparato MUEBLE FRY-TOP FTG-705, FTG-710	Lamina 1	Fagor Industrial S.Coop. FAGOR Ofite 
-------------------	--	------------------	---	-------------	--

MOD.

FRI-TOP

ZONA

MUEBLE

PLANO

C-1250

ITEM	CODIGO	DENOMINACION	TEXTO	FTG-705	FTG-710								NOTAS
1	R165414	Apoyo lateral		6	6								
2	R792603	Liston lateral		2	2								
3	R785416	Plancha de asado Lisa 705		1	-								
3	R795416	Plancha de asado Lisa 710		-	1								
3	R785420	Plancha de asado Cromoduro 705		1	-								
3	R795422	Plancha de asado Cromoduro 710		-	1								
3	R785418	Plancha de asado Rayada 705		1	-								
3	R795420	Plancha de asado Rayada 710		-	1								
3	R795418	Plancha de asado Lisa + Rayada		-	1								
4	S116122	Pomo		1	1								SOLO CROMODURO
5	R619913	Alargadera		1	1								SOLO CROMODURO
6	R619912	Rebosadero-tapon		1	1								SOLO CROMODURO
7	R782607	Liston frontal 705		1	-								
7	R792616	Liston frontal 710		-	1								
	Q262040	Arandela muelle A-6		2	3								
	Q012041	Tornillo exagonal M-6x10		2	3								
8	R782608	Proteccion inferior 705		1	-								
8	R792617	Proteccion inferior 710		-	1								
	Q221342	Remache exagonal M-5		2	2								
	Q152004	Tornillo aplastado M-5x13		2	2								
9	R795006	Tubo desagüe		1	1								
10	R152607	Soporte tubo desagüe		1	1								
	Q262040	Arandela muelle A-6		2	2								
	Q162040	Tuerca exagonal M-6		2	2								
11	R792605	Tirante lateral		2	2								
	Q419005	Remache tubular Ø4x8		4	4								
12	R792806	Lateral derecho de mesa		1	1								
13	X315400	Anterior de mesa 705		1	-								
13	U745407	Anterior de mesa 710		-	1								

MOD.

FRI-TOP

ZONA

MUEBLE

PLANO

C-1250

ITEM	CODIGO	DENOMINACION	TEXTO	FTG-705	FTG-710									NOTAS
	Q221342	Remache exagonal M-5		2	2									
	Q152004	Tornillo aplastado M-5x13		2	2									
14	R782606	Anterior interior de mesa 705		1	-									
14	R792612	Anterior interior de mesa 710		-	1									
	Q419005	Remache tubular Ø4x8		2	2									
15	U732802	Panel lateral derecho		1	1									
16	Q151336	Tornillo soporte guia		2	2									
	Q302022	Arandela plana Ø16xØ6x1,2		4	4									
	Q162040	Tuerca exagonal M-6		2	2									
17	U452804	Cantoneira derecha portamandos		1	1									
	Q419005	Remache tubular Ø4x8		2	2									
18	R962800	Zocalo anterior 705		1	-									
18	R972800	Zocalo anterior 710		-	1									
	Q302022	Arandela plana Ø16xØ6x1,2		2	2									
	Q012031	Tornillo exagonal M-5x10		2	2									
19	U262806	Escudo FAGOR		1	1									
	Q221023	Clip sujecion escudo		2	2									
20	R792606	Caja recoge grasas		1	1									
21	R782805	Panel portamandos 705		1	-									
21	R792810	Panel portamandos 710		-	1									
	Q152004	Tornillo aplastado M-5x13		2	2									
22	U452805	Cantoneira izquierda portamandos		1	1									
	Q419005	Remache tubular Ø4x8		2	2									
23	X312630	Refuerzo amarre mesa 705		1	-									
23	U742620	Refuerzo amarre mesa 710		-	1									
	Q419005	Remache tubular Ø4x8		4	6									
	Q221342	Remache exagonal M-5		2	2									
	Q152004	Tornillo aplastado M-5x13		2	2									
24	X312600	Escuadra amarre mesa 705		1	-									

MOD.

FRI-TOP

ZONA

MUEBLE

PLANO

C-1250

ITEM	CODIGO	DENOMINACION	TEXTO	FTG-705	FTG-710								NOTAS
24	U742607	Escuadra amarre mesa 710		-	1								
	Q221342	Remache exagonal M-5		2	2								
	Q152004	Tornillo aplastado M-5x13		2	2								
25	U722603	Escuadra anterior base bandejas		1	-								
25	R982600	Escuadra anterior base bandejas		-	1								
	Q419005	Remache tubular Ø4x8		4	4								
26	R792609	Guia recoge grasas		1	1								
	Q419005	Remache tubular Ø4x8		4	4								
27	R782803	Base inferior 705		1	-								
27	R792805	Base inferior 710		-	1								
	Q419005	Remache tubular Ø4x8		4	4								
28	R782600	Soporte quemador		1	2								
	Q221342	Remache exagonal M-5		1	2								
	Q419005	Remache tubular Ø4x8		2	4								
29	Z200105	Pata regulable		4	4								
30	Q221345	Remache exagonal M-10		4	4								
31	U732801	Panel lateral izquierdo		1	1								
32	U722803	Panel posterior 705		1	-								
32	U732803	Panel posterior 710		-	1								
	Q419005	Remache tubular Ø4x8		4	4								
33	X010503	Muelle enganche piton		3	4								
	Q419007	Remache tubular Ø3,2x6		6	8								
34	R792804	Lateral izquierdo de mesa		1	1								
35	R782601	Posterior interior de mesa 705		1	-								
35	R792610	Posterior interior de mesa 710		-	1								
	Q012031	Tornillo exagonal M-5x10		2	2								
	Q221342	Remache exagonal M-5		2	2								
36	X315425	Embelledor de chimenea 705		1	-								
36	U745425	Embelledor de chimenea 710		-	1								

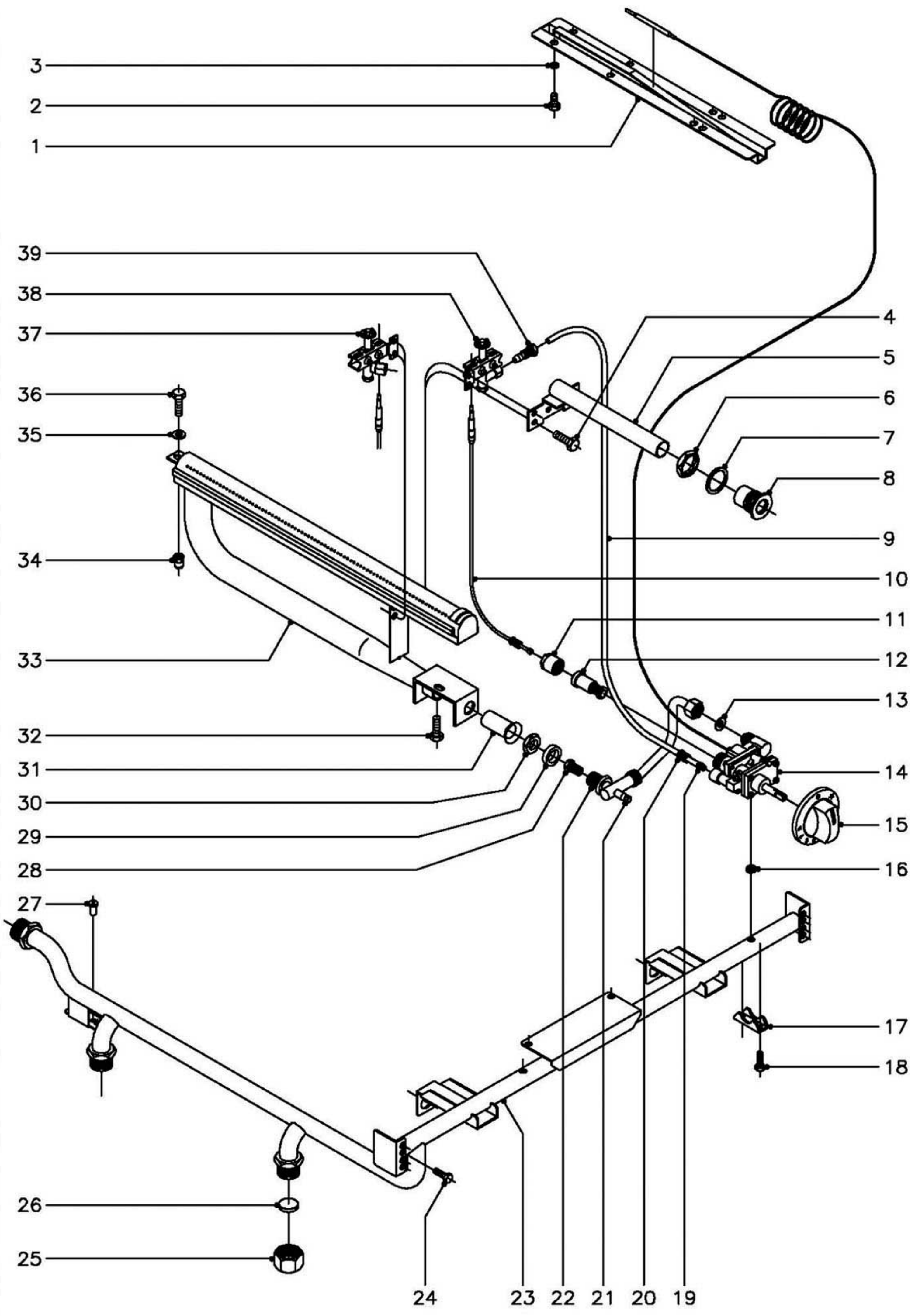

N plano	Firma	Fecha	Aparato	PARTE FUNCIONAL GAS	Lamina	Fager Industrial S.Coop. FAGOR
C-1251	<i>[Signature]</i>	12-2002	FRY-TOP	FTG-705, FTG-710	2	Orate

MOD.		FRI-TOP		ZONA		PARTE FUNCIONAL GAS						PLANO		C-1251	
ITEM	CODIGO	DENOMINACION	TEXTO	FTG-705	FTG-710									NOTAS	
1	R162630	Conjunto soporte bulbo		1	2										
2	Q012041	Tornillo exagonal M-6x10		4	8										
3	Q262040	Arandela muelle A-6		4	8										
4	Q012031	Tornillo exagonal M-5x10		2	4										
5	R165011	Tubo de encendido		1	2										
6	Q221324	Tuerca exagonal 3/4"		1	2										
7	Q306027	Arandela junta Ø33,8xØ27x1,5		1	2										
8	S112804	Embellecedor tubo de encendido		1	2										
9	R785012	Tubo piloto 705		1	-										
9	R795016	Tubo piloto 710		-	2										
10	U222130	Termopar L=600		1	2										
11	6002706	Tapon grupo electromagnetico		1	2										
12	6002705	Grupo electromagnetico		1	2										
13	Q306026	Arandela junta Ø14xØ8,5x1,5		1	2										
14	R782130	Termostato MTZ-7200 (min.-0,70)		1	2										
15	R202106	Boton de mando Ø8		1	2										
16	Q307034	Junta estanqueidad termostato		1	2										
17	Z982018	Brida amarre termostato		1	2										
18	Q151317	Tornillo exagonal M-5x22		2	4										
19	X205028	Bicono Ø6		1	2										
20	U195009	Manguito empalme 1/8" (p/tubo Ø6)		1	2										
21	Q153002	Tornillo tapon (toma presion)		1	2										
22	R785013	Conduccion a quemador 705		1	-										
22	R785004	Conduccion a quemador 710		-	2										
23	R785022	Conduccion general 705		1	-										
23	R795025	Conduccion general 710		-	1										
24	Q012031	Tornillo exagonal M-5x10		4	4										
25	U635008	Tuerca ciega 3/4"		2	2										
26	Q306051	Arandela tapon Ø23,5x3		2	2										

ITEM	CODIGO	DENOMINACION	TEXTO	FTG-705	FTG-710										NOTAS
27	Q419005	Remache tubular Ø4x8		2	2										
28	R422400	Tobera quemador Ø1,25 (B.P.)		1	2										
28	9429500	Tobera quemador Ø1,90 (G.N.)		1	2										
28	R792400	Tobera quemador Ø4,00 (G.V.)		1	2										
29	Q301323	Arandela Ø25xØ17x6		1	2										
30	Q223019	Tuerca exagonal 3/8"		1	2										
31	U325707	Regulador de aire		1	2										
32	Q012032	Tornillo exagonal M-5x15		1	2										
33	R795700	Quemador		1	2										
34	Q221342	Remache exagonal M-5		1	2										
35	Q302022	Arandela plana Ø16xØ6x1,2		1	2										
36	Q012031	Tornillo exagonal M-5x10		1	2										
37	U322118	Piloto completo		-	2										
38	U322118	Piloto completo		1	-										
	U442138	Inyector piloto Ø0,25 (B.P. y G.V.)		1	2									Regular para Gas Villa	
	U442137	Inyector piloto Ø0,40 (G.N.)		1	2										
39	U134323	Racord con bicono Ø6		1	2										

MOD.

FRI-TOP

ZONA

VARIOS

PLANO

ITEM

CODIGO

DENOMINACION

TEXTO

FTG-705

FTG-710

NOTAS

R166502

Folleto de instrucciones

1

1

R636500

Rasqueta Martor

1

1

SOLO CROMODURO

MOD.

FRI-TOP

ZONA

PIEZAS ESPECIFICAS PARA LOS DISTINTOS GASES

PLANO

C-1251

ITEM	CODIGO	DENOMINACION	TEXTO	FTG-705	FTG-710														NOTAS
		<u>BUTANO - PROPANO</u>																	
28	R422400	Tobera quemador Ø1,25		1	2														
37y38	U442138	Inyector piloto Ø0,25		1	2														
		<u>GAS NATURAL</u>																	
28	9429500	Tobera quemador Ø1,90		1	2														
37y38	U442137	Inyector piloto Ø0,40		1	2														
		<u>GAS VILLA</u>																	
28	R792400	Tobera quemador Ø4,00		1	2														
37y38	U442138	Inyector piloto Ø0,25		1	2														Regular para Gas Villa

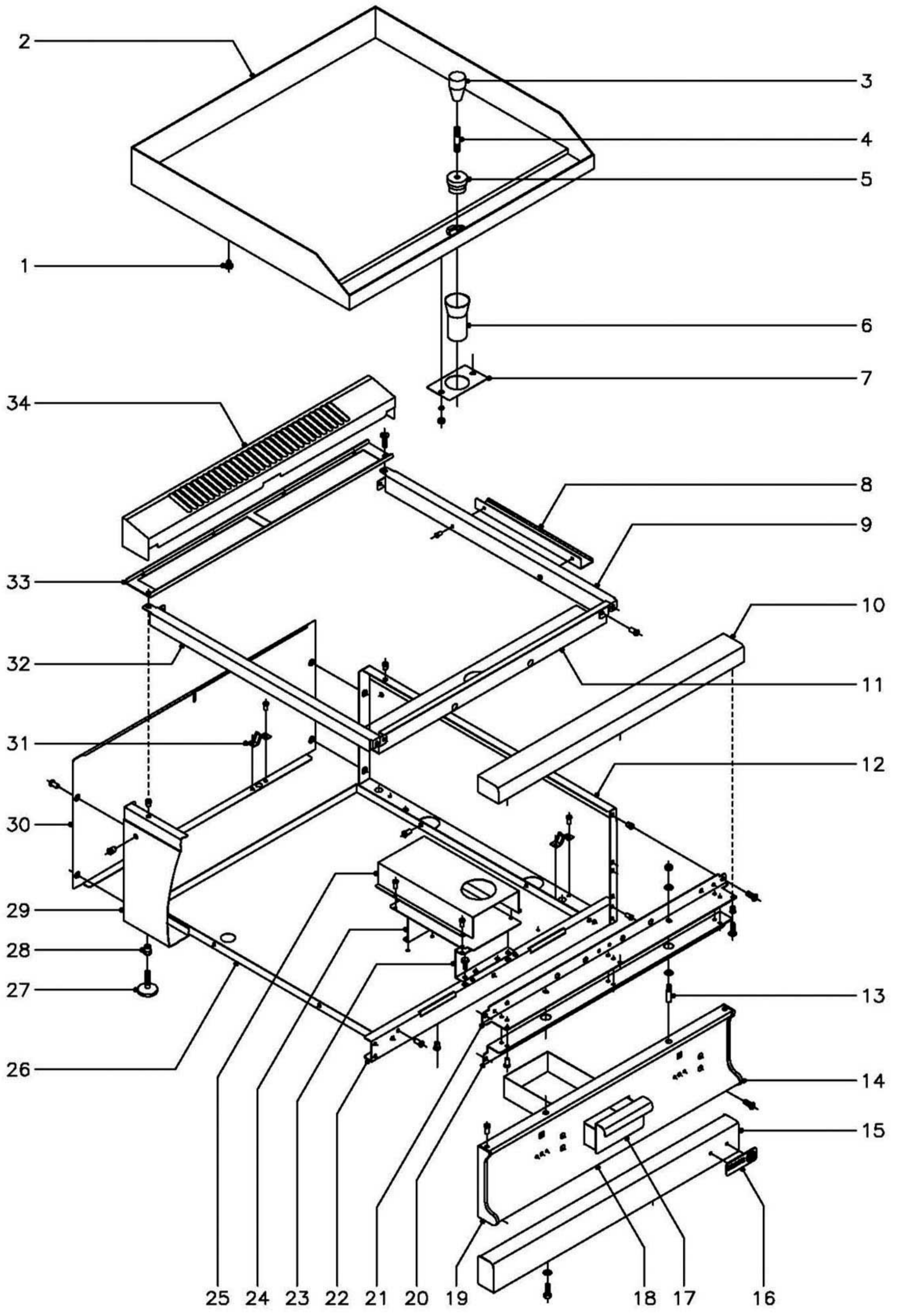

MOD.		FRI-TOP		ZONA	MUEBLE						PLANO	C-1252
ITEM	CODIGO	DENOMINACION	TEXTO	FTE-705	FTE-710							NOTAS
1	R165414	Apoyo lateral		6	6							
2	R885416	Plancha de asado Lisa 705		1	-							
2	R895416	Plancha de asado Lisa 710		-	1							
2	R885420	Plancha de asado Cromoduro 705		1	-							
2	R895422	Plancha de asado Cromoduro 710		-	1							
2	R885418	Plancha de asado Rayada 705		1	-							
2	R895420	Plancha de asado Rayada 710		-	1							
2	R895418	Plancha de asado Lisa + Rayada		-	1							
3	S116122	Pomo		1	1							SOLO CROMODURO
4	R619913	Alargadera		1	1							SOLO CROMODURO
5	R619912	Rebosadero-tapon		1	1							SOLO CROMODURO
6	R795006	Tubo desagüe		1	1							
7	R152607	Soporte tubo desagüe		1	1							
	Q262040	Arandela muelle A-6		2	2							
	Q162040	Tuerca exagonal M-6		2	2							
8	R792605	Tirante lateral		2	2							
	Q419005	Remache tubular Ø4x8		4	4							
9	R792806	Lateral derecho de mesa		1	1							
10	X315400	Anterior de mesa 705		1	-							
10	U745407	Anterior de mesa 710		-	1							
	Q221342	Remache exagonal M-5		2	2							
	Q152004	Tornillo aplastado M-5x13		2	2							
11	R782606	Anterior interior de mesa 705		1	-							
11	R792612	Anterior interior de mesa 710		-	1							
	Q419005	Remache tubular Ø4x8		2	2							
12	U732802	Panel lateral derecho		1	1							
13	Q151336	Tornillo soporte guia		2	2							
	Q302022	Arandela plana Ø16xØ6x1,2		4	4							
	Q162040	Tuerca exagonal M-6		2	2							

MOD.

FRI-TOP

ZONA

MUEBLE

PLANO

C-1252

ITEM	CODIGO	DENOMINACION	TEXTO	FTE-705	FTE-710								NOTAS
14	U452804	Cantoneira derecha portamandos		1	1								
	Q419005	Remache tubular Ø4x8		2	2								
15	R962800	Zocalo anterior 705		1	-								
15	R972800	Zocalo anterior 710		-	1								
	Q302022	Arandela plana Ø16xØ6x1,2		2	2								
	Q012031	Tornillo exagonal M-5x10		2	2								
16	U262806	Escudo FAGOR		1	1								
	Q221023	Clip sujecion escudo		2	2								
17	R792606	Caja recoge grasas		1	1								
18	R882800	Panel portamandos 705		1	-								
18	R892800	Panel portamandos 710		-	1								
	Q152004	Tornillo aplastado M-5x13		2	2								
19	U452805	Cantoneira izquierda portamandos		1	1								
	Q419005	Remache tubular Ø4x8		2	2								
20	X312630	Refuerzo amarre mesa 705		1	-								
20	U742620	Refuerzo amarre mesa 710		-	1								
	Q419005	Remache tubular Ø4x8		4	6								
	Q221342	Remache exagonal M-5		2	2								
	Q152004	Tornillo aplastado M-5x13		2	2								
21	X312600	Escuadra amarre mesa 705		1	-								
21	U742607	Escuadra amarre mesa 710		-	1								
	Q221342	Remache exagonal M-5		2	2								
	Q152004	Tornillo aplastado M-5x13		2	2								
22	U722603	Escuadra anterior base bandejas		1	-								
22	U732601	Escuadra anterior base bandejas		-	1								
	Q419005	Remache tubular Ø4x8		4	4								
23	R892603	Soporte guia recoge grasas		1	1								
	Q221342	Remache exagonal M-5		2	2								
	Q012031	Tornillo exagonal M-5x10		2	2								

MOD.

FRI-TOP

ZONA

MUEBLE

PLANO

C-1252

ITEM	CODIGO	DENOMINACION	TEXTO	FTE-705	FTE-710									NOTAS
24	R892604	Guia recoge grasas		1	1									
	Q419005	Remache tubular Ø4x8		2	2									
25	R892605	Cubierta recoge grasas		1	1									
	Q419005	Remache tubular Ø4x8		4	4									
26	R962601	Base inferior 705		1	-									
26	R972600	Base inferior 710		-	1									
	Q419005	Remache tubular Ø4x8		4	4									
27	Z200105	Pata regulable		4	4									
28	Q221345	Remache exagonal M-10		4	4									
29	U732801	Panel lateral izquierdo		1	1									
30	U722803	Panel posterior 705		1	-									
30	U732803	Panel posterior 710		-	1									
	Q419005	Remache tubular Ø4x8		4	4									
31	X010503	Muelle enganche piton		3	4									
	Q419007	Remache tubular Ø3,2x6		6	8									
32	R792804	Lateral izquierdo de mesa		1	1									
33	R782601	Posterior interior de mesa 705		1	-									
33	R792610	Posterior interior de mesa 710		-	1									
	Q012031	Tornillo exagonal M-5x10		2	2									
	Q221342	Remache exagonal M-5		2	2									
34	X315425	Embelledor de chimenea 705		1	-									
34	U745425	Embelledor de chimenea 710		-	1									

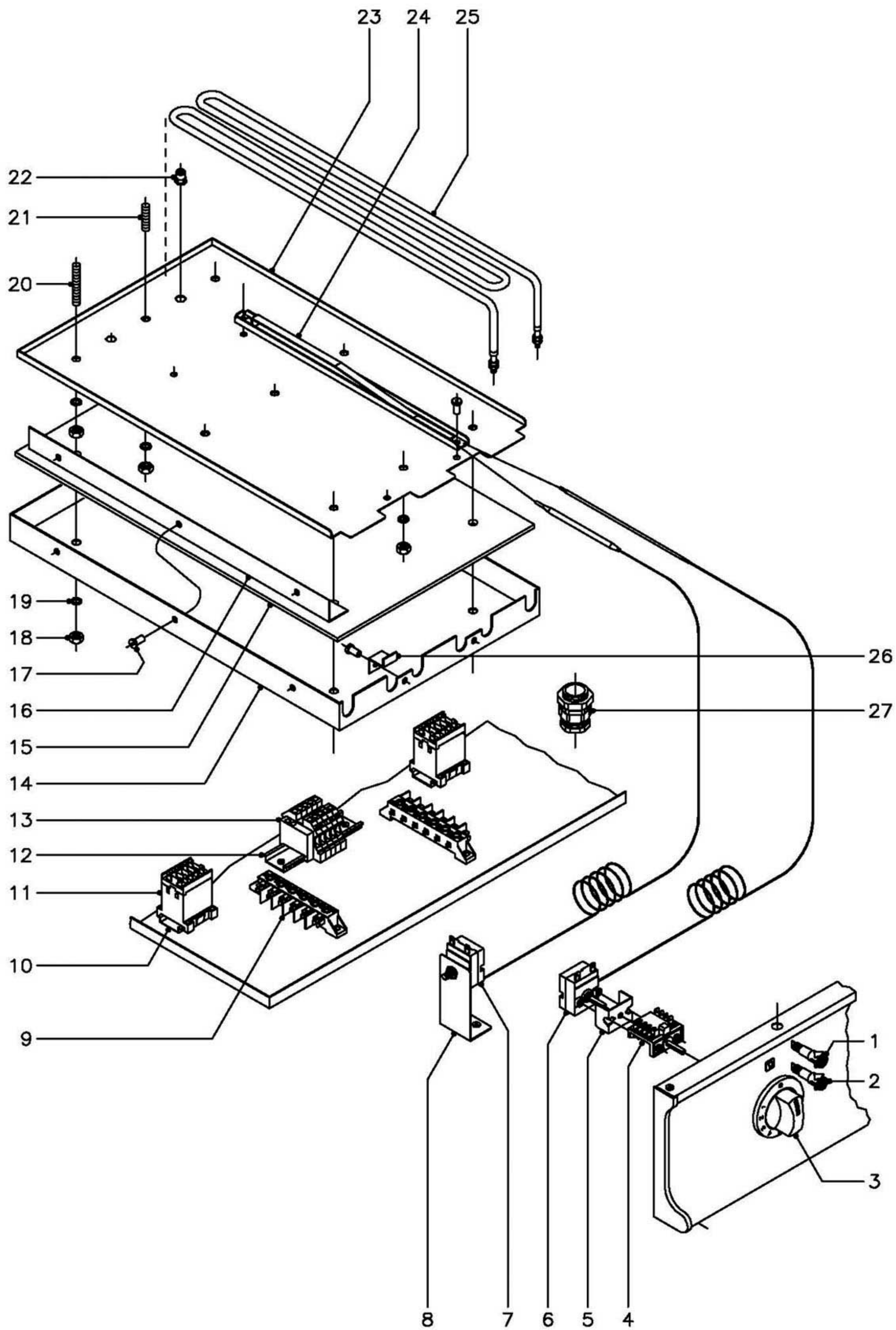

N plano
C-1253

Firma

Fecha
12-2002

Aparato
FRY-TOP FTE-705, FTE-710

PARTE FUNCIONAL ELECTRICA

Lamina
4

Fagor Industrial S.Coop. **FAGOR**
Onate

MOD.	FRI-TOP	ZONA	PARTE FUNCIONAL ELECTRICA	PLANO	C-1253
------	---------	------	---------------------------	-------	--------

ITEM	CODIGO	DENOMINACION	TEXTO	FTE-705	FTE-710								NOTAS
1	R693055	Piloto verde		1	2								
2	R693056	Piloto ambar		1	2								
3	U673017	Boton de mando Ø6		1	2								
	Q281000	Anillo de compresion para boton		1	2								
4	X163007	Conmutador acople termostato		1	2								
5	X313001	'U" soporte termostato		1	2								
6	X153000	Termostato 50 - 310° C.		1	2								
7	R612103	Termostato limitador		1	2								
8	R572607	Soporte limitador		1	2								
9	R253044	Regleta		1	2								
10	Z123018	Guia contactor L=55		1	2								
11	Z213007	Contacto 3TF2010 - 3AL2		1	2								
12	R663055	Guia contactor L=120		-	1								
13	P453025	Borna fases 10 (gris)		-	3								
	Z263302	Borna neutro 10 (azul)		-	1								
	P453026	Borna tierra 10 (verde - amarillo)		-	1								
	Z263303	Tope final		-	1								
14	R882600	Cubierta resistencias 705		1	-								
14	R892600	Cubierta resistencias 710		-	1								
15	R885410	Aislante resistencias 705		1	-								
15	R895410	Aislante resistencias 710		-	2								
16	R892602	Fijacion lateral aislante		2	4								
17	Q419005	Remache tubular Ø4x8		6	12								
18	Q162050	Tuerca exagonal M-8		13	26								
19	Q262050	Arandela muelle A-8		13	26								
20	Q131557	Varilla roscada M-8x50		4	8								
21	Q131555	Varilla roscada M-8x30		5	10								
22	Q221343	Remache exagonal M-6		2	4								
23	R882602	Amarre resistencias 705		1	-								

MOD.

FRI-TOP

ZONA

PARTE FUNCIONAL ELECTRICA

PLANO

C-1253

ITEM	CODIGO	DENOMINACION	TEXTO	FTE-705	FTE-710									NOTAS
23	R892606	Amarre resistencias 710		-	2									
24	R592630	Conjunto soporte bulbo		1	2									
	Q419005	Remache tubular Ø4x8		2	4									
25	R893000	Resistencia 1500 W., 230 V.		3	6									
26	U615409	Distanciadore		1	2									
	Q419005	Remache tubular Ø4x8		1	2									
27	R013022	Prensaestopas		1	-									
27	R023013	Prensaestopas		-	1									

MOD.

FRI-TOP

ZONA

VARIOS

PLANO

ITEM	CODIGO	DENOMINACION	TEXTO	FTE-705	FTE-710								NOTAS
	R596502	Folleto de instrucciones		1	1								
	R636500	Rasqueta Martor		1	1								SOLO CROMODURO
	R563000	Esquema electrico adhesivo		1	-								Plano HB-14936
	R573001	Esquema electrico adhesivo		-	1								Plano HC-71227
	R573005	Esquema electrico de montaje		1	1								Plano HC-71229
	R223000	Cableado portamandos		1	2								
	R223003	Cableado contactor a resistencias		1	2								
	R223002	Cableado regleta a contactor		1	2								
	R573003	Cable a limitador		1	2								
	R573002	Cableado regleta a bornas		-	2								
	X183008	Cableado regleta a contactor		-	2								

FTE-905 FTE-705

NOTAS

- Las inscripciones resistirán sin modificación apreciable el frotamiento durante 15 seg. de un algodón impregnado en gasolina.

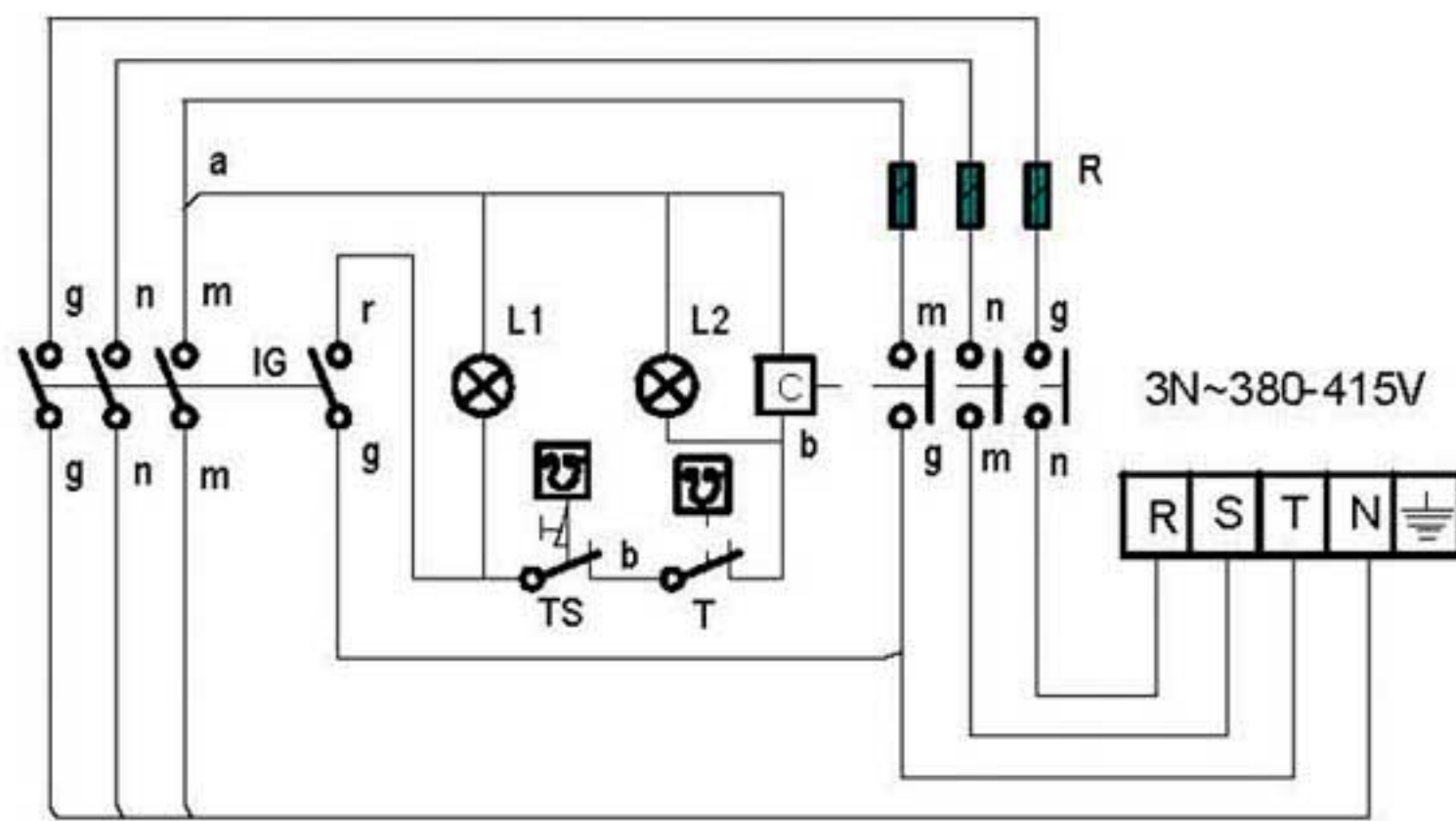

- IG: Interruptor general
- L1: Lámpara funcionamiento
- T: Termostato regulable (50-310°C)
- L2: Lámpara calentamiento
- C: Contactor de calentamiento
- R: Resistencias
- TS: Termostato seguridad (400°C)

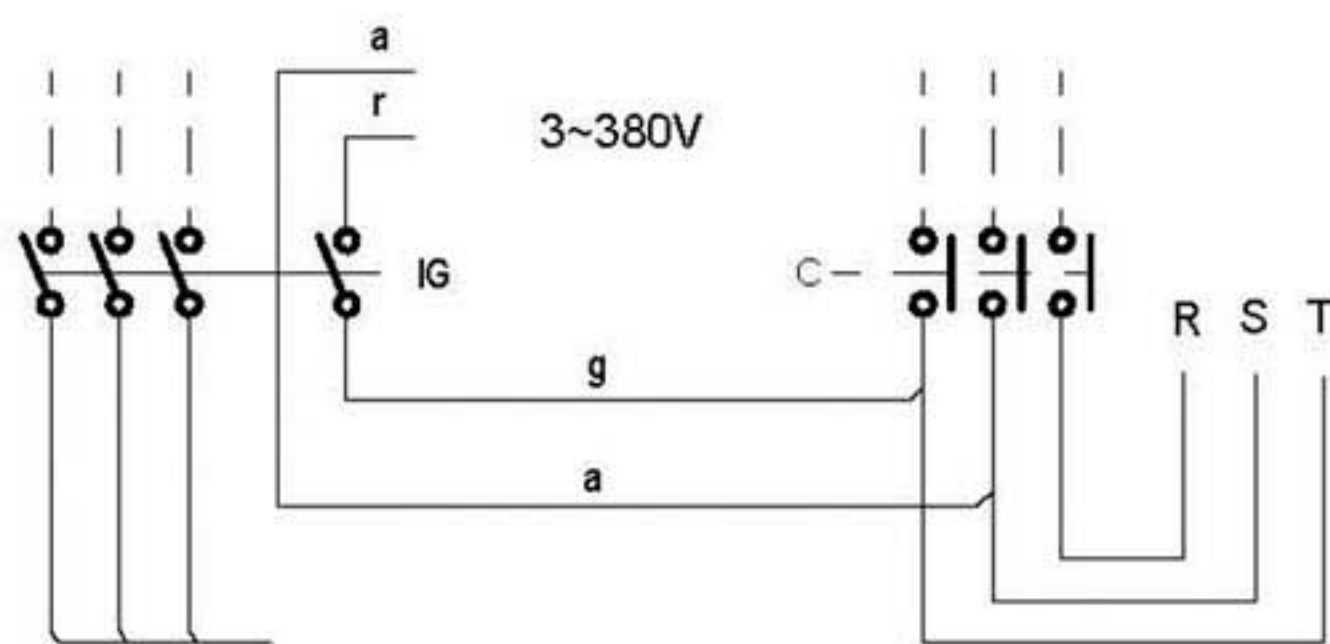
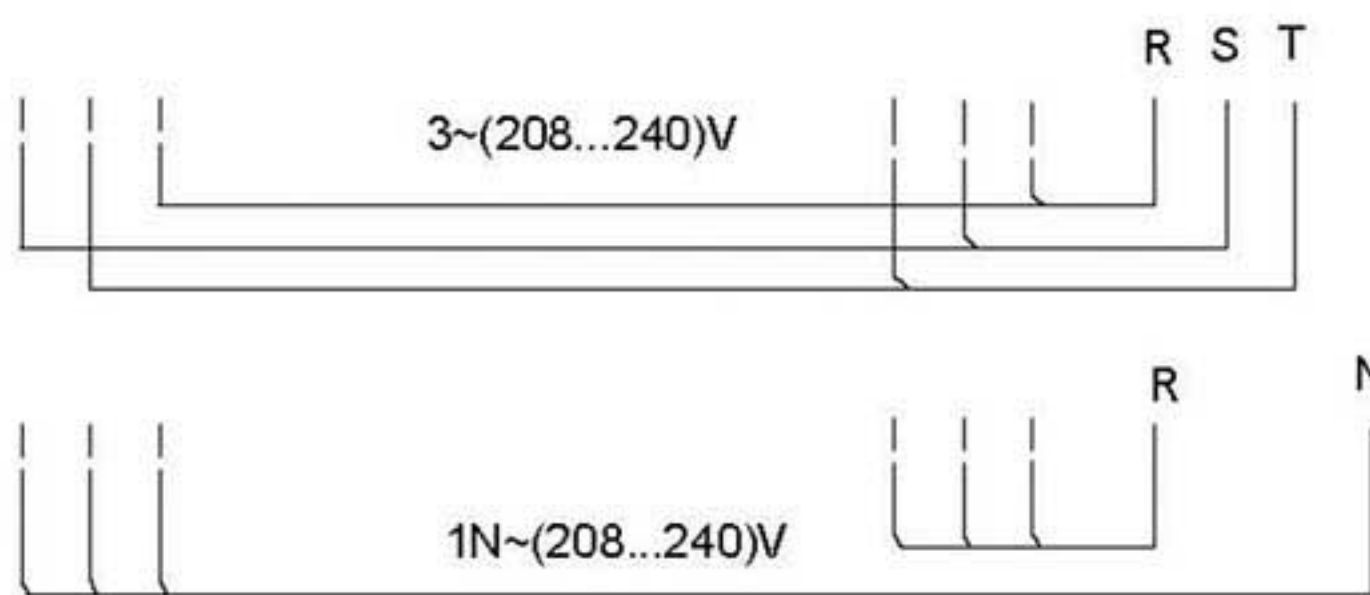

- r = rojo-red-rouge
- m = marron-brown-marron
- g = gris-grey-gris
- n = negro-black-noir
- a = azul-blue-bleu
- b = blanco-white-blanc
- vi = violeta-violette-violet
- am/ve = amarillo/verde
yellow/green
jaune/vert

Esquema teorico adhesivo				R-563000	
Nº	Pieza	Cant.	Material	Nº Clasificacion	Acabado
Nº	Modificacion	Propuesta de		Fecha	Tolerancias generales
①	Introducir TS	Maillo		95-6-14	$< 5 \pm$ $5 - 25 \pm$ $25 - 50 \pm$ $50 - 100 \pm$ $> 100 \pm$ $\infty \pm$
②	Introducir FTE-705	Etxeberria		1-7-97	
③	Introducir G-700	Etxeberria		8-7-97	
Firma		Fecha		Mecanizado superficial	
Dibujado		95-5-23			
Proyectado					
Comprobado					
Escala		FRY-TOP			Plano numero
					HB-14936 -3
		Plano hau ez daiteke erabil ez berrizta gure baimenitz gabe			Sustituye al Nº
					Sustituido por



Fagor Industrial, Koop. Elk, Mugatua

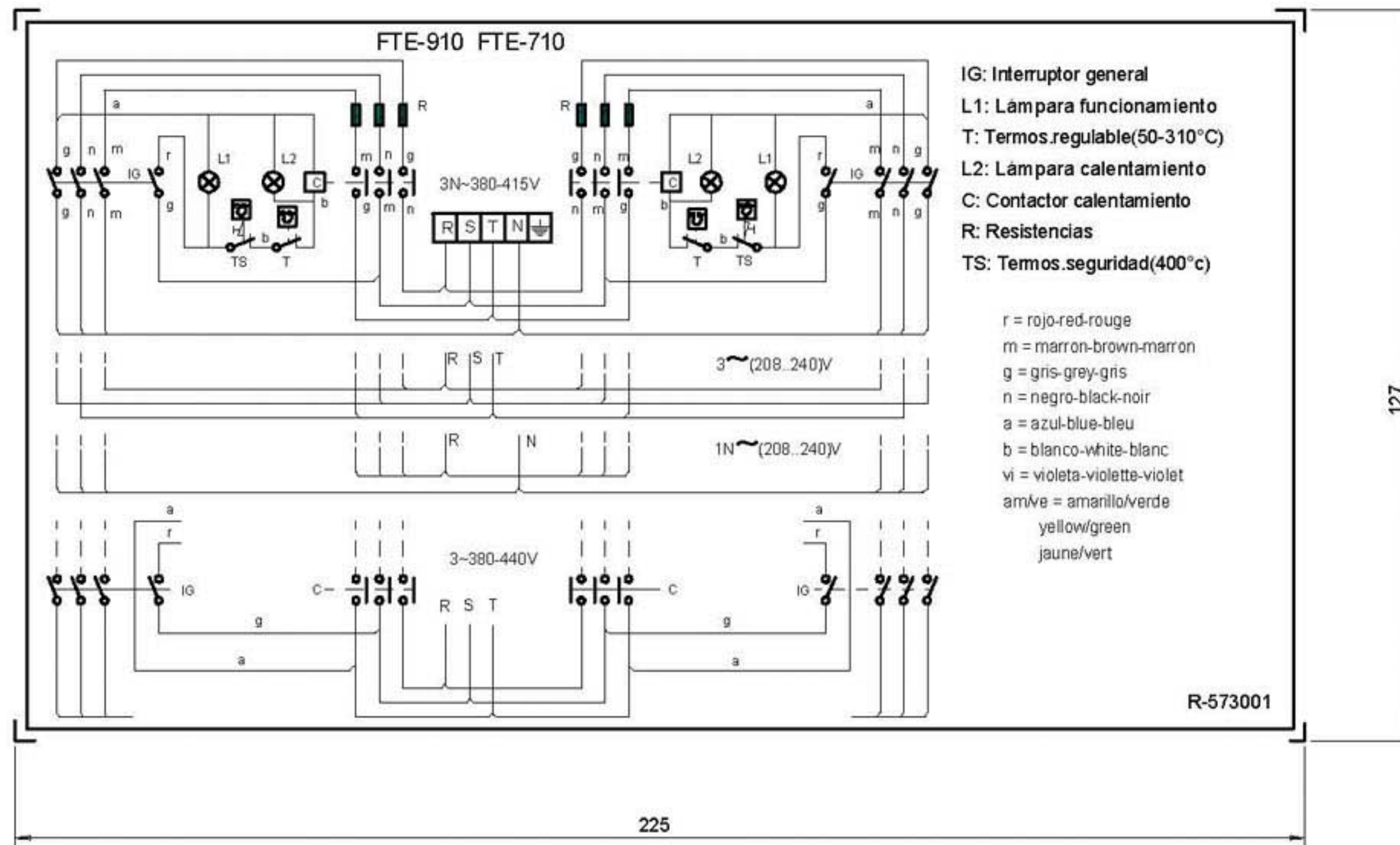

NOTA

- Las inscripciones resistirán sin modificación apreciable el frotamiento durante 15 seg. de un algodón impregnado en gasolina.

Plastico blanco alto brillo

Esquema teorico adhesivo		R-573001		
Nº	Pieza	Material	Nº Clasificacion	Acabado
Nº	Modificacion	Propuesta de	Fecha	Tolerancias generales
1	Introducir TS	Maillo	95-6-14	$\leq 5\pm$ $5-25\pm$ $25-50\pm$ $50-100\pm$ $> 100\pm$ $\infty\pm$
2	Modific.general(pasar a fabric.interior)	Plazaola	23-4-97	
3	Introducir FTE-705	Etzeberria	1-7-97	
4	Introducir G 700	Maillo	11/7/97	
Dibujado	JON	Fecha	95-5-23	Mecanizado superficial
Proyectado				
Comprobado	<i>Leticia</i>	Fagor Industrial,Koop Elk, Mugatua		
Escala	1/1	FRY-TOP		Plano numero HC-71227 -4
Plano hau ez dateke erabil ez berria gure baimentz gabe				Sustituido por

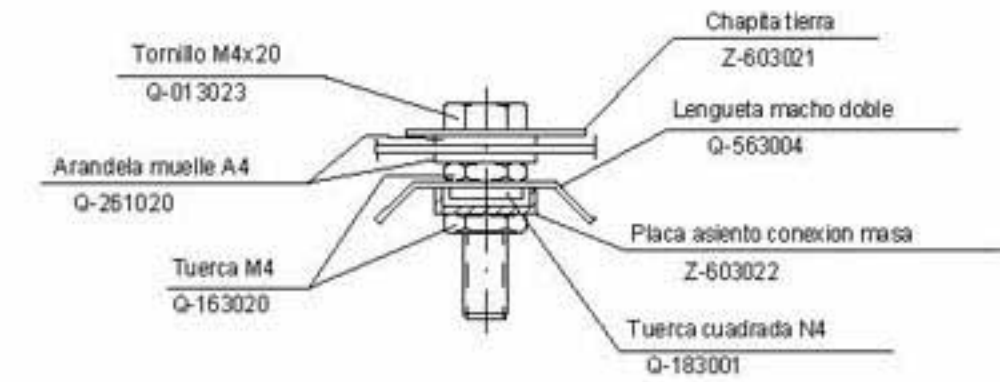
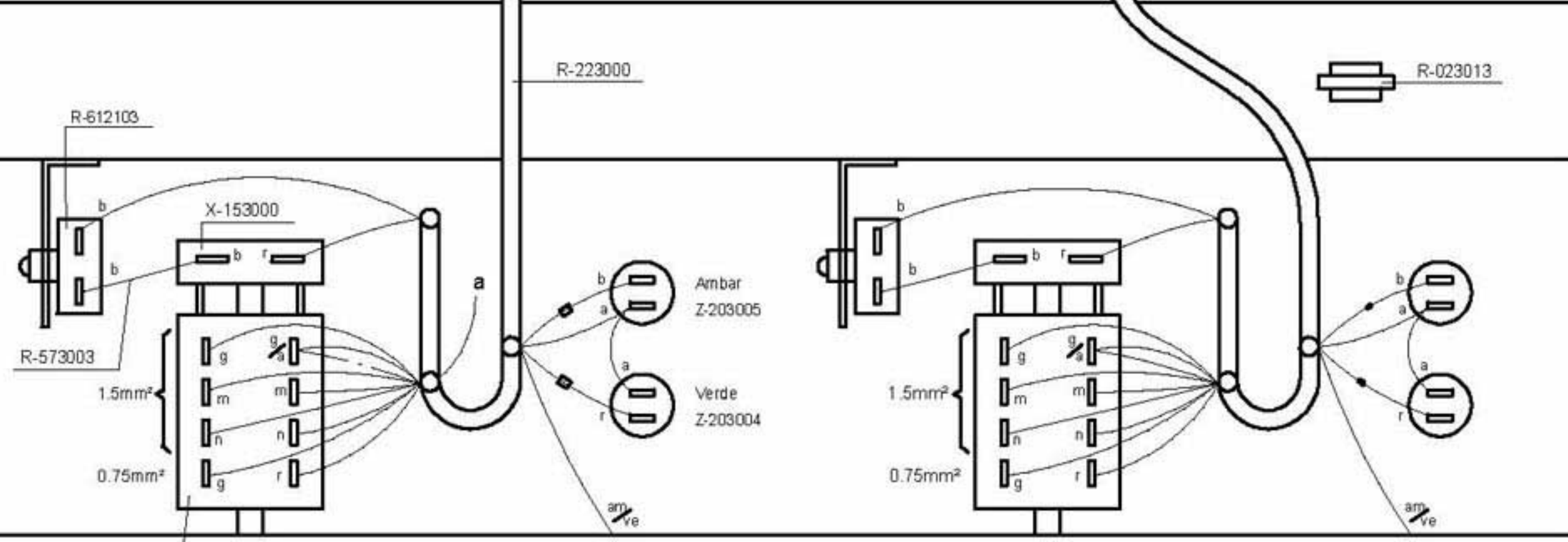
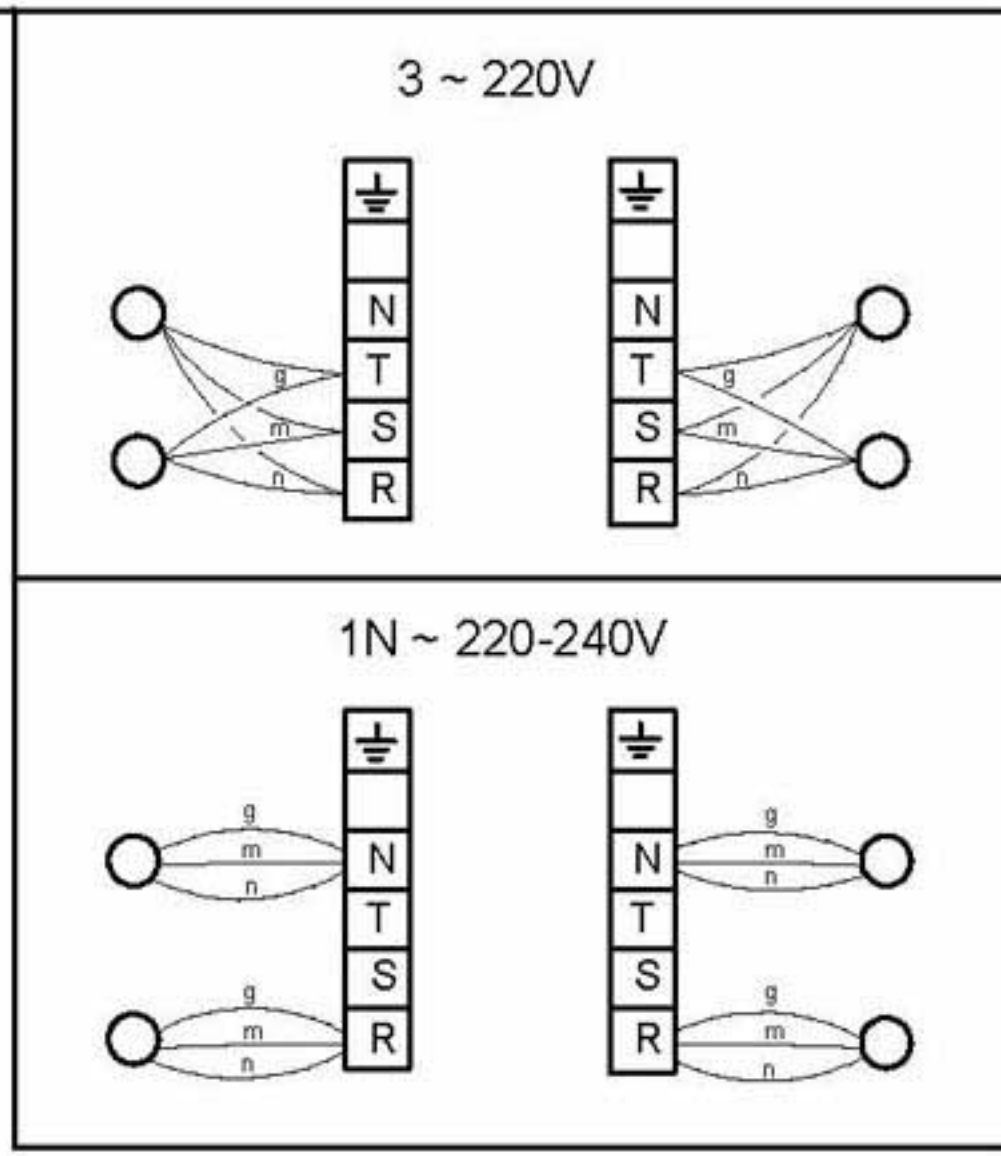
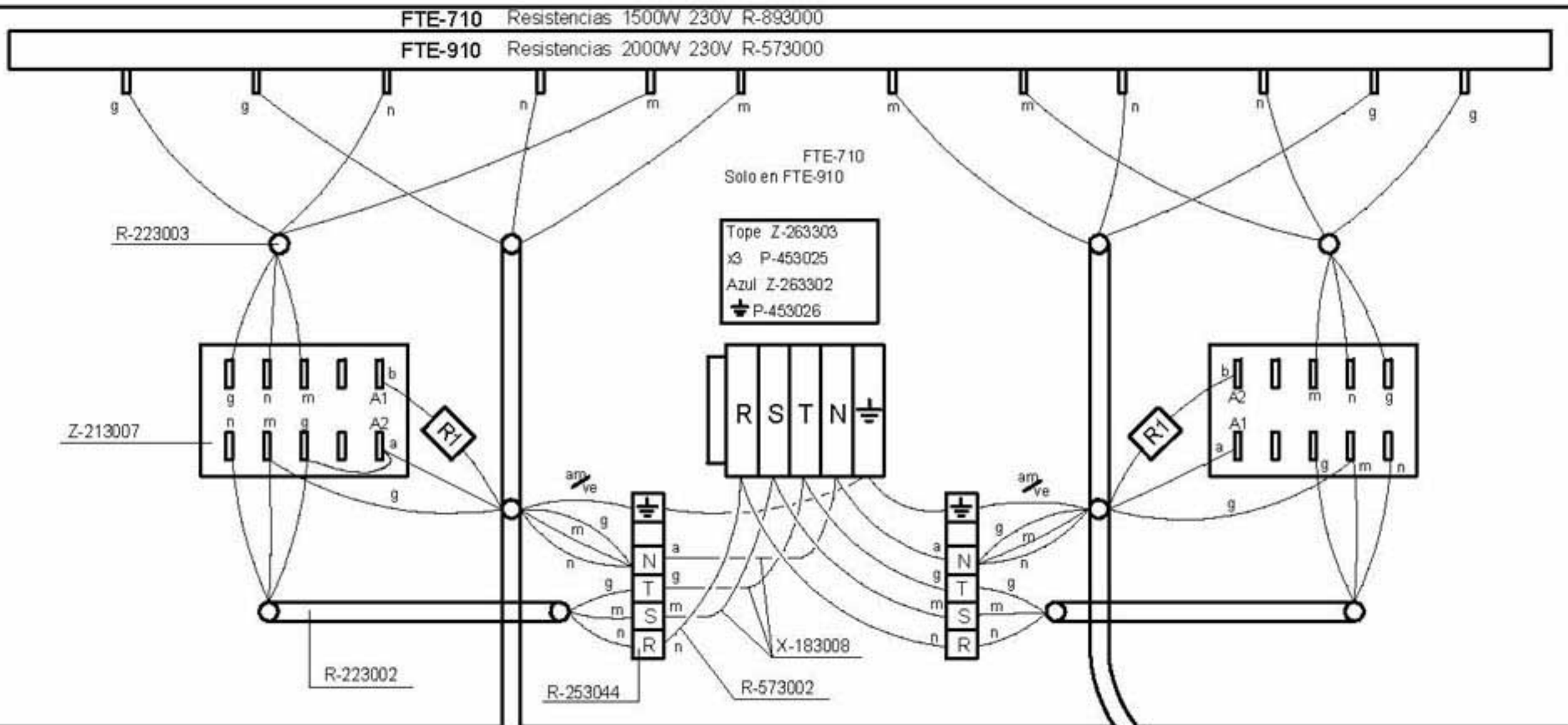

Esquema Adhesivo
 FTE-710 FTE-910 R-573001
 FTE-705 FTE-905 R-563000

VERSION SIN NEUTRO
 ----- Conexión
 ■ U-803072 R-150KOhm 1/4W
 □ U-803073 R-8K2Ohm 6W

Esquema de montaje 3N ~ 380V			R-573005		
Nº	Pieza	Cart.	Material	Nº Clasificación	Acabado
Nº	Modificación	Propuesta de		Fecha	Tolerancias generales
1	Introducir G-700	Maillo		14/7/97	<5± : 50-100± : 5-25± : >100± : 25-50± : CX±
Dibujado	Firma	Fecha	Fagor Industrial, Koop. Elk, Mugatua		
Proyectado	JON	95-9-25			
Comprobado					
Escala					
FRY-TOP ELECTRICO			Mecanizado superficial		
			Plano numero HC-71229 -1		
Plano hau ez datat e erabil ez berizta gure baimentz gabe			Sustituye al N°		
			Sustituido por		