

**Fry-tops eléctricos  
Electric fry-tops  
Fry-tops électriques  
Elektro griddle-platten  
Fry-tops elettrici  
Fry-tops elétricos**

**GAMA SNACK**

**Modelos:**

**FTE6-05**

**FTE6-10**

**FTE/C6-05**

**FTE/C6-10**

***Junio 2009 June***

***Revisado Mayo 2013 May Revised***



---

F A G O R I N D U S T R I A L

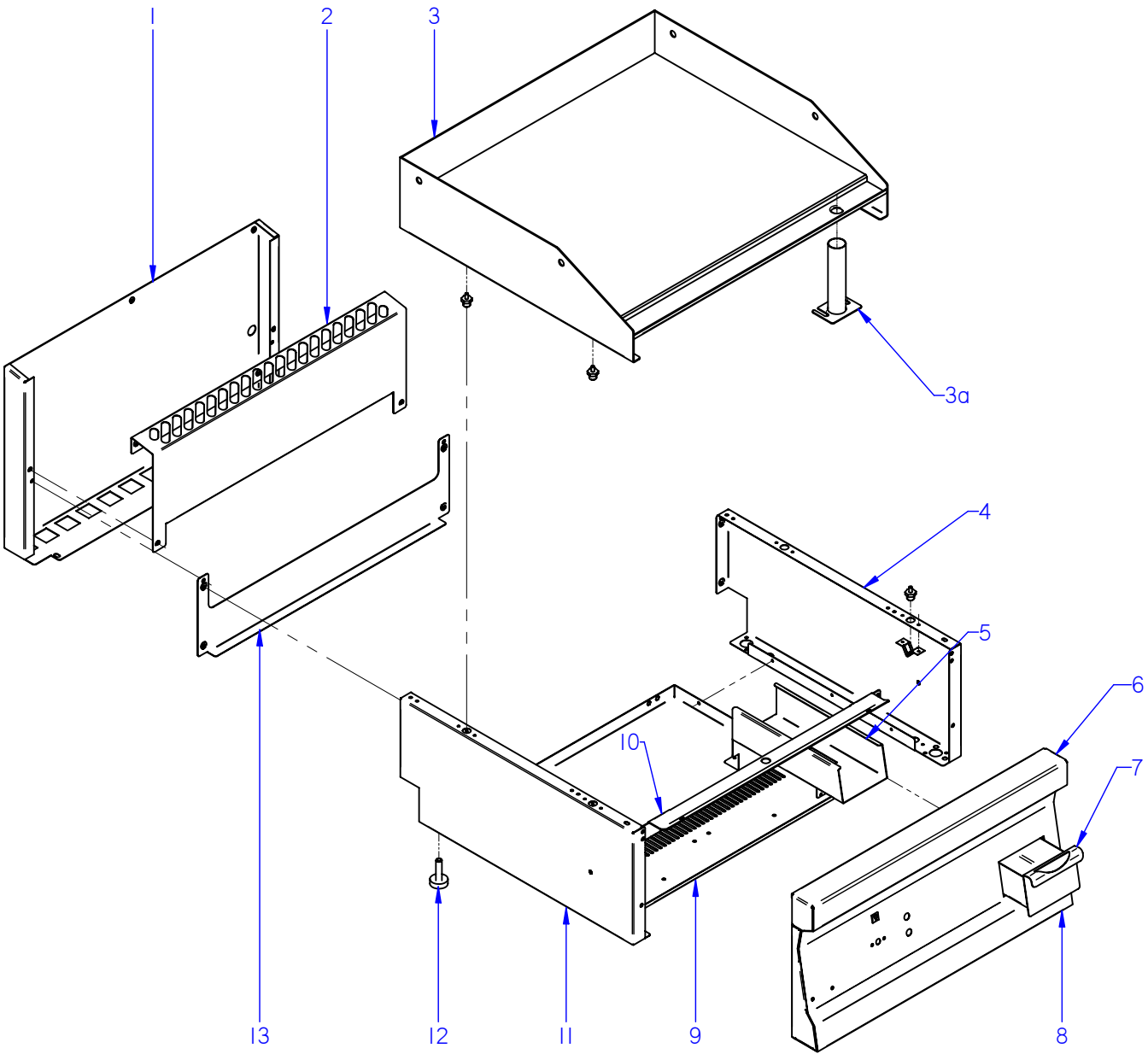

ITEM MARCADO EN COLOR = REPUESTO RECOMENDADO  
 COLOURED ITEM = RECOMMENDED SPARE PART

N plano C-2387	Firma <i>(Firma)</i>	Fecha 2009-06	Aparato FRY-TOP FTE6-05 / FTE6-10	MUEBLE	Lamina 1	Fagor Industrial S. Coop. Omate
-------------------	-------------------------	------------------	--------------------------------------	--------	-------------	------------------------------------



MOD.		FRY-TOP		ZONA	MUEBLE / UNIT					PLANO	C-2387
ITEM	CODIGO	DENOMINACION	TEXTO	FTE6-05	FTE6-10						NOTAS
1	J142809000	PROTECC. CHIMENEA POST. 400	PROTECTION CHIMEMEY POS.	1	_						ELIMINADO 27.11.11
1	J142815000	PROTECTOR CHIMENEA FRYES 400	PROTECTION CHIMEMEY POS.	1	_						INTRODUCIDO 27.11.11
1	J142812000	PROTECC. CHIMENEA POST. 600	PROTECTION CHIMEMEY POS.	_	1						ELIMINADO 27.11.11
1	J142816000	PROTECTOR CHIMENEA POST 600	PROTECTION CHIMEMEY POS.	_	1						INTRODUCIDO 27.11.11
	Q419005000	REMACHE 4X8 ALMG3 / ALUMINIO	RIVET 4X8 ALMG3 / ALUMINIUM	2	2						
2	J142810000	PROTECCION CHIMENEA ANT. 400	PROTECTION CHIMENEY ANT	1	_						ELIMINADA 01.04.2010
2	J142829000	PROTECCION CHIMENEA FREID.	PROTECTION CHIMENEY	1	_						ELIMINADO 27.11.11
2	12041345	PROT. CHIME. 400 FRY-TOP SNACK	400 FRY-TOP SNACK PROT.CHI.	1	_						INTRODUCIDO 27.11.11
2	J142813000	PROTECCION CHIMENEA ANT. 600	PROTECTION CHIMENEY ANT	_	1						ELIMINADA 01.04.2010
2	J142830000	PROTECCION CHIMENEA ANT. 600	PROTECTION CHIMENEY ANT	_	1						ELIMINADO 27.11.11
2	12041347	PROT. CHIME. 600 FRY-TOP SNACK	600 FRY-TOP SNACK PROT.CHI.	_	1						INTRODUCIDO 27.11.11
	Q012031000	TORNILLO EXAGONAL M5x10 A304	HEXAGONAL BOLT M5x10 A304	4	4						
	Q302022000	ARANDELA 16x6x1,2 A304	WASHER 16x6x1.2 A304	4	4						
	Q221342000	REMACHE EXAGONAL M5	HEXAGONAL RIVET M5	3	3						
3	J115432000	PLANCHA SNACK E 400 L	PLATE SNACK E 400 L	1	_						ELIMINADO 27.08.2012
3	12046163	PLANCHA FTE6-05 L COMPL.	PLATE FTE6-05 L COMPL.	1	_						INTRODUCIDO 27.08.2012
3	J115434000	PLANCHA SNACK E 400 R	PLATE SNACK E 400 R	1	_						ELIMINADO 27.08.2012
3	12046230	PLANCHA FTE6-05 R COMPL.	PLATE FTE6-05 R COMPL.	1	_						INTRODUCIDO 27.08.2012
3	J115435000	PLANCHA SNACK E 400 L CD	PLATE SNACK E 400 L CD	1	_						ELIMINADO 27.08.2012
3	12046232	PLANCHA FTE/C6-05 L COMPL.	PLATE FTE/C6-05 L COMPL.	1	_						INTRODUCIDO 27.08.2012
3	J115433000	PLANCHA SNACK E 600 L	PLATE SNACK E 600 L	_	1						ELIMINADO 27.08.2012
3	12046220	PLANCHA FTE6-10 L COMPL.	PLATE FTE6-10 L COMPL.	_	1						INTRODUCIDO 27.08.2012
3	J115436000	PLANCHA SNACK E 600 R	PLATE SNACK E 600 R	_	1						ELIMINADO 27.08.2012
3	12046238	PLANCHA FTE6-10 R COMPL.	PLATE FTE6-10 R COMPL.	_	1						INTRODUCIDO 27.08.2012
3	J115440000	PLANCHA SNACK E 600 L+R	PLATE SNACK E 600 L+R	_	1						ELIMINADO 27.08.2012
3	12046235	PLANCHA FTE6-10 L+ R COMPL.	PLATE FTE6-10 L+ R COMPL.	_	1						INTRODUCIDO 27.08.2012
3	J115437000	PLANCHA SNACK E 600 L CD	PLATE SNACK E 600 L CD	_	1						ELIMINADO 27.08.2012
3	12046243	PLANCHA FTE/C6-10 L COMPL.	PLATE FTE/C6-10 L COMPL.	_	1						INTRODUCIDO 27.08.2012
3	J115441000	PLANCHA SNACK E 600 L+R CD	PLATE SNACK E 600 L+R CD	_	1						ELIMINADO 27.08.2012
3	12046249	PLANCHA FTE/C6-10 L+R COMPL.	PLATE FTE/C6-10 L+R COMPL.	_	1						INTRODUCIDO 27.08.2012
3a	12040911	TUBO VACIADO FRY-TOP SNACK	FRY-TOP SNACK DRAIN PIPE	1	1						INTRODUCIDO 03.10.11

MOD.		FRY-TOP		ZONA	MUEBLE / UNIT					PLANO	C-2387
ITEM	CODIGO	DENOMINACION	TEXTO	FTE6-05	FTE6-10						NOTAS
S/Nº	J105436000	APOYO PLANCHA FRY-TOP	PLATE SUPPORT	4	4						
	Q221342000	REMACHE EXAGONAL M5	HEXAGONAL RIVET M5	6	6						
4	J002802000	PANEL LATERAL DERECHO	RIGHT SIDE PANEL	1	1						ELIMINADA 01.04.2010
4	J002834000	PANEL LATERAL DERECHO	RIGHT SIDE PANEL	1	1						INTRODUC. 01.04.2010
	Q221342000	REMACHE EXAGONAL M5	HEXAGONAL RIVET M5	1	1						
	Q419007000	REMACHE TUBULAR C/V D3.2X6	TUBULAR RIVET C/V D3.2X6	8	8						
	X010503000	CIERRE MUELLE	LOCK SPRING	4	4						ELIMINADA 01.04.2010
	Z442918000	CLIP CIERRE	LOCK SPRING	4	4						INTRODUC. 01.04.2010
5	J112602000	GUIA RECOGEGRASAS FRY-TOP	GREASE COLLECTION GUIDE	1	1						
	Q419005000	REMACHE 4X8 ALMG3 / ALUMINIO	RIVET 4X8 ALMG3 / ALUMINIUM	4	4						
6	J105432000	ANTERIOR FRY-TOP 400	FRONT FRY-TOP 400	1	—						ELIMINADO 27.08.2012
6	J105434000	ANTERIOR FRY-TOP 600	FRONT FRY-TOP 600	—	1						ELIMINADO 27.08.2012
7	J112810000	CAJA RECOGEGRASAS	GREASE COLLECTION TRAY	1	1						
8	J112806000	PORTAMANDOS COMPL. FTE6-05	CONTROL HOLDER FTE6-05	1	—						
8	J112808000	PORTAMANDOS COMPL. FTE6-10	CONTROL HOLDER FTE6-10	—	1						
	U022836000	ESCUDO FAGOR	FAGOR EMBLEM	1	1						
	Q221023000	CLIP SUJECIÓN RÁPIDA Ø5	RAPID CONNECT CLIP Ø5	2	2						
	Q419005000	REMACHE 4x8 ALMG3 / ALUMINIO	RIVET 4X8 ALMG3 / ALUMINIUM	6	6						
	Q012031000	TORNILLO EXAGONAL M5x10 A304	HEXAGONAL BOLT M5x10 A304	2	2						
	Q302022000	ARANDELA 16x6x1,2 A304	WASHER 16x6x1.2 A304	2	2						
9	J002604000	BASE INFERIOR FTE6-05 SNACK	LOWER BASE FTE6-05 SNACK	1	—						
9	J002607000	BASE INFERIOR FTE6-10 SNACK	LOWER BASE FTE6-10 SNACK	—	1						
	Q419005000	REMACHE 4X8 ALMG3 / ALUMINIO	RIVET 4X8 ALMG3 / ALUMINIUM	6	6						
10	J102616000	GUÍA PANEL FRY-TOP 400	GUIDE PANEL FRY-TOP 400	1	—						ELIMINADA 26.08.2012
10	12002559	GUÍA PANEL OF CONTROLS 400	GUIDE PAN. OF CONTROLS 400	1	—						INTRODUCIDA 26.08.2012
13	J102617000	GUÍA PANEL FRY-TOP 600	GUIDE PANEL FRY-TOP 600	—	1						ELIMINADA 26.08.2012
13	12002749	GUÍA PANEL OF CONTROLS 600	GUIDE PAN. OF CONTROLS 600	—	1						INTRODUCIDA 26.08.2012
10	J102617000	GUÍA PANEL FRY-TOP 600	GUIDE PANEL FRY-TOP 600	—	1						
	Q221342000	REMACHE EXAGONAL M5	HEXAGONAL RIVET M5	4	4						
	Q012031000	TORNILLO EXAGONAL M5x10 A304	HEXAGONAL BOLT M5x10 A304	4	4						

MOD.	FRY-TOP	ZONA	MUEBLE / UNIT	PLANO	C-2387
------	---------	------	---------------	-------	--------

ITEM	CODIGO	DENOMINACION	TEXTO	FTE6-05	FTE6-10								NOTAS
11	J002801000	PANEL LATERAL IZQUIERDO	LEFT SIDE PANEL	1	1								ELIMINADA 01.04.2010
11	J002833000	PANEL LATERAL IZQUIERDO	LEFT SIDE PANEL	1	1								INTRODUC. 01.04.2010
	Q221342000	REMACHE EXAGONAL M5	HEXAGONAL RIVET M5	1	1								
	Q419007000	REMACHE TUBULAR C/V D3.2X6	TUBULAR RIVET C/V D3.2X6	8	8								
	X010503000	CIERRE MUELLE	LOCK SPRING	4	4								ELIMINADA 01.04.2010
	Z442918000	CLIP CIERRE	LOCK SPRING	4	4								INTRODUC. 01.04.2010
12	Z200107000	PATA REGULABLE	ADJUSTABLE LEG	4	4								
13	J112803000	PANEL POSTERIOR FRY-TOP 400	REAR PANEL FRY-TOP 400	1	—								
13	J112809000	PANEL POSTERIOR FRY-TOP 600	REAR PANEL FRY-TOP 600	—	1								
	Q419005000	REMACHE 4x8 ALMG3 / ALUMINIO	RIVET 4X8 ALMG3 / ALUMINIUM	4	4								

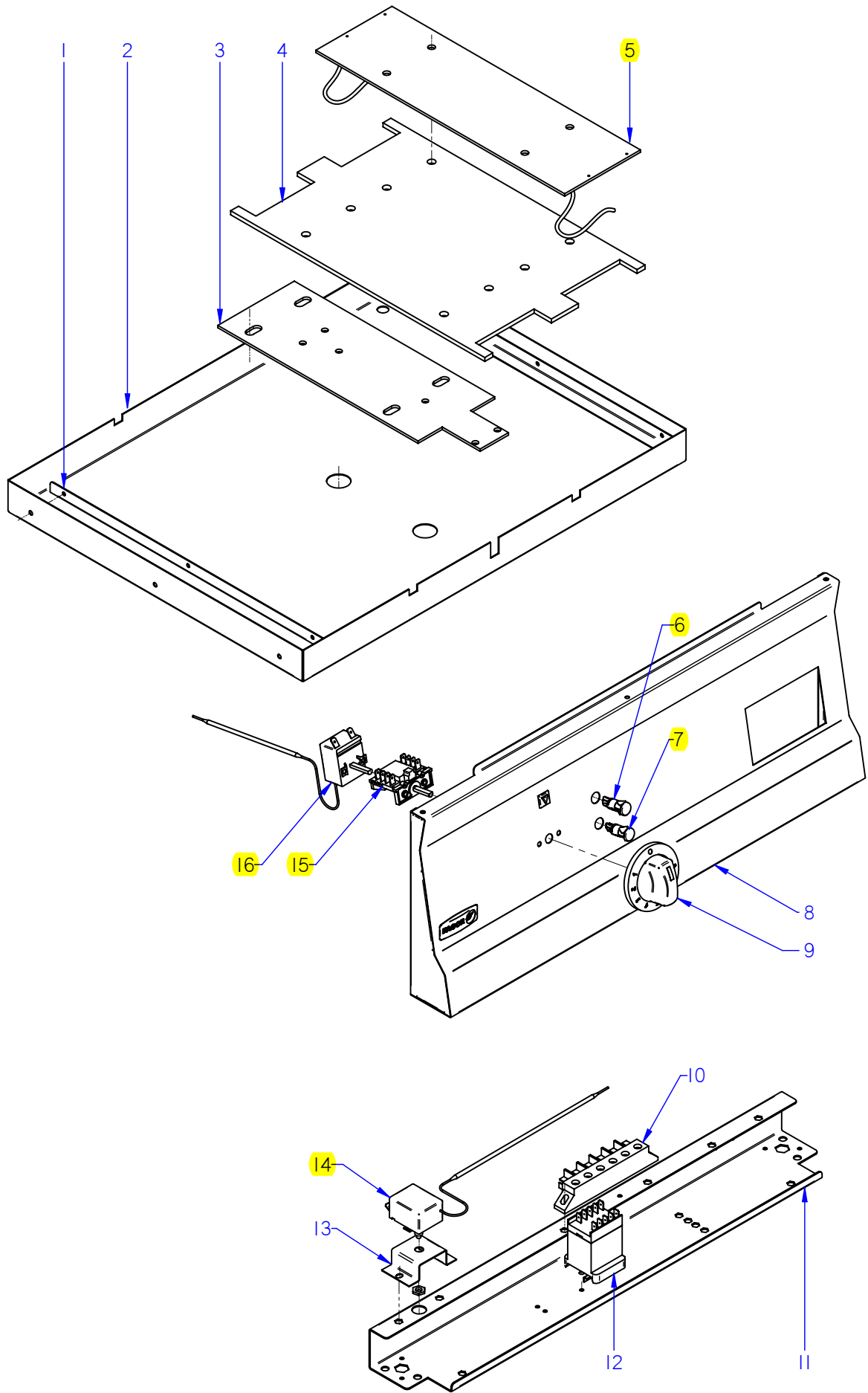

ITEM MARCADO EN COLOR = REPUESTO RECOMENDADO  
 COLOURED ITEM = RECOMMENDED SPARE PART

N plano	Firma	Fecha	Aparato	CONJUNTO FUNCIONAL	Lamina	Fagor Industrial S.Coop. <b>FAGOR</b>
C-2388	<i>[Signature]</i>	2009-06	FRY-TOP FTE6-05 / FTE6-10		2	Oñate

MOD.	FRY-TOP		ZONA	CONJUNTO FUNCIONAL / FUNCTIONAL UNIT					PLANO	C-2388
ITEM	CODIGO	DENOMINACION	TEXTO	FTE6-05	FTE6-10					NOTAS
1	J112609000	LISTON TOPE BARLAN	STRIP BARLAN	2	2					ELIMINADA 26.08.2012
	Q419005000	REMACHE 4X8 ALMG3 / ALUMINIO	RIVET 4X8 ALMG3 / ALUMINIUM	6	6					
2	J112608000	CUBIERTA RESISTENC. FTE6-05	RESISTOR COVER FTE6-05	1	-					ELIMINADA 27.08.2012
2	12046170	CUBIERTA RESISTENC. FTE6-05	RESISTOR COVER FTE6-05	1	-					INTRODUCIDA 27.08.2012
2	J112610000	CUBIERTA RESISTENC. FTE6-10	RESISTOR COVER FTE6-10	-	1					ELIMINADA 27.08.2012
2	12046222	CUBIERTA RESISTENC. FTE6-10	RESISTOR COVER FTE6-10	-	1					INTRODUCIDA 27.08.2012
	Q162040000	TUERCA EXAGONAL M6	HEXAGONAL NUT M6	4	4					
	Q302040000	ARANDELA A6	WASHER A6	4	4					
3	J112606000	SOPOR. TOPE BULBO FTE SNACK	BULB SUPPORT FTE SNACK	1	1					ELIMINADA 27.08.2012
3	12046226	BASE TOPE	BASE TOP	2	2					INTRODUCIDA 27.08.2012
4	J115413000	PLETINA RESIST. FTE SNACK	RESIST.PLATE FTE SNACK	1	2					ELIMINADA 26.08.2012
	Q162040000	TUERCA EXAGONAL M6	HEXAGONAL NUT M6	8	16					ELIMINADA 26.08.2012
	Q302040000	ARANDELA A6	WASHER A6	8	16					ELIMINADA 26.08.2012
5	J303001000	RESISTENCIA 1600W 230V	RESISTOR 1600W 230V	3	4					ELIMINADA 27.08.2012
5	12024620	RESISTENCIA 230V.1500W.SBE-710	RESISTOR 230V.1500W.SBE-710	3	-					INTRODUCIDA 27.08.2012
5	12046197	RESISTENCIA 230V 2,10KW 440MM	RESISTOR 30V 2,10KW 440MM	-	3					INTRODUCIDA 27.08.2012
6	R693055000	PILOTO VERDE 41227000C7	GREEN PILOT 41227000C7	1	1					ELIMINADO 01.02.13
6	12047390	PILOTO VERDE 230V AC 8KW 16MM	GREEN PILOT 230V AC 8KW 16MM	1	1					INTRODUCIDO 01.02.13
7	R693056000	PILOTO AMBAR 41227000A4	AMBER PILOT 41227000A4	1	1					ELIMINADO 01.02.13
7	12024669	PILOTO AMBAR Ø18	AMBER PILOT Ø18	1	1					INTRODUCIDO 01.02.13
8	J112806000	PORTAMANDOS COMPL. FTE6-05	CONTROL HOLDER FTE6-05	1	-					
8	J112808000	PORTAMANDOS COMPL. FTE6-10	CONTROL HOLDER FTE6-10	-	1					
9	X482101000	BOTON DE MANDO Ø6 G-750Q	CONTROL BUTTON Ø6 G-750Q	1	1					
10	R253044000	REGLETA AUXILIAR FV-122	AUXILIARY TERMINAL STRIP FV-	1	1					
	Q152004000	TORNIL. APLASTADO M5X13 A 304	FLAT HEADED SCREW M5x13 A 3	2	2					
11	J102601000	SOPORTE FRONTAL 400	FRONT SUPPORT 400	1	-					
11	J002605000	SOPORTE FRONTAL 600	FRONT SUPPORT 600	-	1					
12	Z213007000	CONTACTOR 230 V. 50-60 HZ	CONTACTOR 230 V. 50-60 HZ	1	1					
	Z123018000	GUIA CONTACTOR L-55	CONTACTOR GUIDE L-55	1	1					
	Q419005000	REMACHE 4X8 ALMG3 / ALUMINIO	RIVET 4X8 ALMG3 / ALUMINIUM	2	2					

MOD.

FRY-TOP

ZONA

CONJUNTO FUNCIONAL / FUNCTIONAL UNIT

PLANO

C-2388

ITEM	CODIGO	DENOMINACION	TEXTO	FTE6-05	FTE6-10							NOTAS
13	X152661000	SOPORTE LIMITADOR	LIMITER SUPPORT	1	1							
	Q221341000	REMACHE EXAGONAL M4	HEXAGONAL RIVET M4	2	2							
14	R612103000	TERMOSTATO LIMITADOR	THERMOSTAT LIMITER	1	1							
15	X163007000	CONMUTADOR ACOUPLE TERMOS	THERMOSTAT CONNECT SWITCH	1	1							
	Q151320000	TOR. ALOMADO M4X6 H.ZINCADO	CURVED SCREW M4X6 H. ZINC	2	2							
16	X153000000	TERMOSTATO 50-310 C	THERMOSTAT 50-310 C	1	1							



<b>MOD.</b>	<b>FRY-TOP</b>	<b>ZONA</b>	<b>VARIOS / MISCELLANEOUS</b>	<b>PLANO</b>	
-------------	----------------	-------------	-------------------------------	--------------	--

<b>ITEM</b>	<b>CODIGO</b>	<b>DENOMINACION</b>	<b>TEXTO</b>	<b>FTE6-05</b>	<b>FTE6-10</b>								<b>NOTAS</b>
	J116503000	FOLLETO DE INSTR. FTE SNACK	INSTRUC. LEAFLET FTE SNACK	1	1								
	J113001000	ESQUEMA TEORICO FTE6-05	THEOR. DIAGRAM FTE6-05	1	-								PLANO HB-80492
	J113002000	ESQUEMA TEORICO FTE6-10	THEOR. DIAGRAM FTE6-10	-	1								PLANO HB-80493
	J113007000	ESQUEMA MONTAJE FTE	ASSEMBLY DIAGRAM FTE	1	1								PLANO HC-81170
	J153006000	CABLEADO CONT. RESISTENCIAS	RESISTORS WIRING CONNECT.	-	1								
	R223002000	CABLEADO REGLETA CONTACT.	CONTACTOR CONTROL WIRING	1	1								
	J153005000	CABLEADO PORTAMANDOS	CONTROL HOLDER WIRING	1	1								
	R223003000	CABLEADO CONT. RESISTENCIAS	CONNECT. WIRING RESISTORS	1	1								
	12043762	CABLEADO TIERRA ELECTROVAL.	WIRING SOLENOID GROUND	1	1								INTRODUCIDA 15.10.12

MOD.	FRY-TOP	ZONA	REPUESTOS RECOMENDADOS RECOMMENDED SPARE PART	PLANO
------	---------	------	--	-------

ITEM	CODIGO	DENOMINACION	TEXTO	FTE6-05	FTE6-10							NOTAS
5	12024620	RESISTENCIA 230V.1500W.SBE-710	RESISTOR 230V.1500W.SBE-710	3								C-2388
5	12046197	RESISTENCIA 230V 2,10KW 440MM	RESISTOR 30V 2,10KW 440MM		3							C-2388
6	12047390	PILOTO VERDE 230V AC 8KW 16MM	GREEN PILOT 230V AC 8KW 16MM	1	1							C-2388
7	12024669	PILOTO AMBAR Ø18	AMBER PILOT Ø18	1	1							C-2388
14	R612103000	TERMOSTATO LIMITADOR	THERMOSTAT LIMITER	1	1							C-2388
15	X163007000	CONMUTADOR ACOPLA TERMOS	THERMOSTAT CONNECT SWITCH	1	1							C-2388
16	X153000000	TERMOSTATO 50-310 C	THERMOSTAT 50-310 C	1	1							C-2388

# FTE6-05

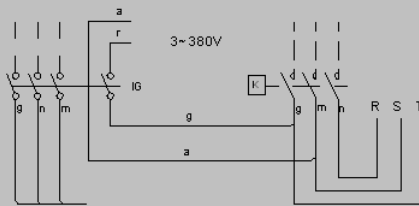
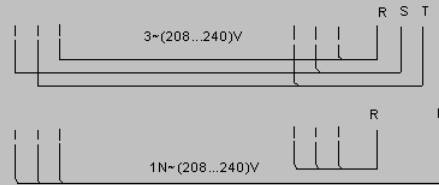
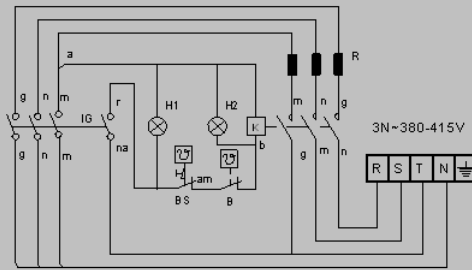

B: Termostato regulable/Adjustable thermostat regulable  
 BS: Termostato de seguridad/Security thermostat  
 IG: Interruptor general/Main switch  
 K: Contactor/Contactor  
 H1: Luz de encendido/Operation lamp  
 H2: Luz de calentamiento/Heating lamp  
 R: Resistencia/Resistance

a = azul-blue  
 am/ve = amarillo/verde - yellow/green  
 b = blanco-white  
 g = gris-grey  
 m = marron-brown  
 n = negro-black  
 na = naranja - orange  
 r = rojo-red

Theoretical diagram: FTE6-05				J11300 1000	-	
Zk /N°	Pieza	Cant.	Material/Material	Klas. zk/N° Clas.	Gainazal akabera/Tratamiento	
Zk /N°	Aldaketa/Modificaciones		Nork proposatua/Propuesta de	Data/Fecha	Perdoi orokorrak Tolerancias generales	
-	-		-	-		
-	-		-	-	$< 5 \pm 0.2$   $50 - 100 \pm 0.8$	
-	-		-	-	$5 + 25 \pm 0.4$   $> 100 \pm 1$	
-	-		-	-	$25 + 50 \pm 0.6$   $\varnothing \pm 1$	
	Sinadura/Firma	Data/Fecha	 Fagor Industrial, Koop. Elk., Mugatua		Gainazal perdoia Mecanizado superficial	
Marratzua/Dibujado	e.carrascal	2008-10-20				
Proiektatua/Proyectado	e.carrascal	2008-10-20				
Egiaztatua/Comprobado	<i>[Signature]</i>	2008-10-20				
Eskala/Escala	<b>COOKING</b>				Plano Zk./Plano N° <b>HB-80492</b>	
-	Plano hau ezin daiteke erabili, ez berrizatu, gure baimenik gabe.				- Zk. ord. du	
-					- Zk.gaitik ord.	

# FTE6-10

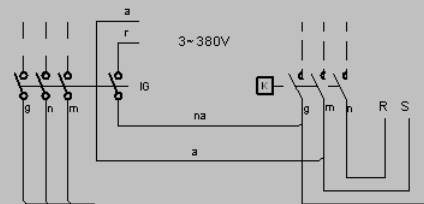
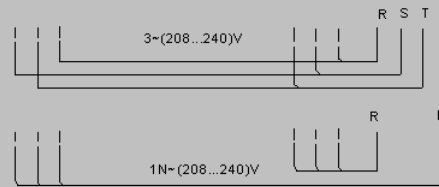
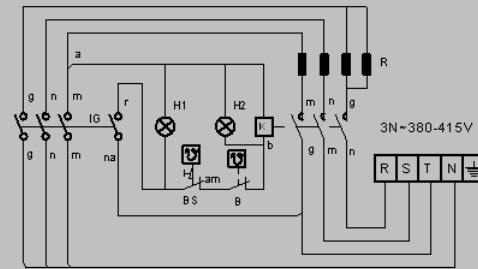

B: Termostato regulable/Adjustable thermostat regulable  
 BS: Termostato de seguridad/Security thermostat  
 IG: Interruptor general/Main switch  
 K: Contactor/Contactor  
 H1: Luz de encendido/Operation lamp  
 H2: Luz de calentamiento/Heating lamp  
 R: Resistencia/Resistance

a = azul-blue  
 am/ve = amarillo/verde - yellow/green  
 b = blanco-white  
 g = gris-grey  
 m = marron-brown  
 n = negro-black  
 na = naranja - orange  
 r = rojo-red

Theoretical diagram: FTE6-10				J113002000	-
Zk /N°	Pieza	Cant.	Material/Material	Klas. zk/N° Clas.	Gainazal akabera/Tratamiento
Zk /N°	Aldaketa/Modificaciones		Nork proposatua/Propuesta de	Data/Fecha	Perdoi orokorrak Tolerancias generales
-	-	-	-	-	-
-	-	-	-	-	$< 5 \pm 0.2$   $50 - 100 \pm 0.8$
-	-	-	-	-	$5 + 25 \pm 0.4$   $> 100 \pm 1$
-	-	-	-	-	$25 + 50 \pm 0.6$   $\varnothing \pm 1$
	Sinadura/Firma	Data/Fecha	 Fagor Industrial, Koop. Elk., Mugatua		Gainazal perdoia Mecanizado superficial
Marratzua/Dibujado	e.carrascal	2008-10-20			
Proiektatua/Proyectado	e.carrascal	2008-10-20			
Egiaztatua/Comprobado	<i>[Signature]</i>	2008-10-20			
Eskala/Escala	<b>COOKING</b>				Plano Zk./Plano N° <b>HB-80493</b>
-	Plano hau ezin daiteke erabili, ez berrizatu, gure baimenik gabe.				- Zk. ord. du
-					- Zk.gaitik ord.

FTE 610 4x1,6KW J303001000  
 FTE 605 3x1,6KW J303001000  
 CMF 605 2x1,6KW J303001000  
 FE 605 2x2,75KW J153007000  
 CPE 605 2x3KW J153002000

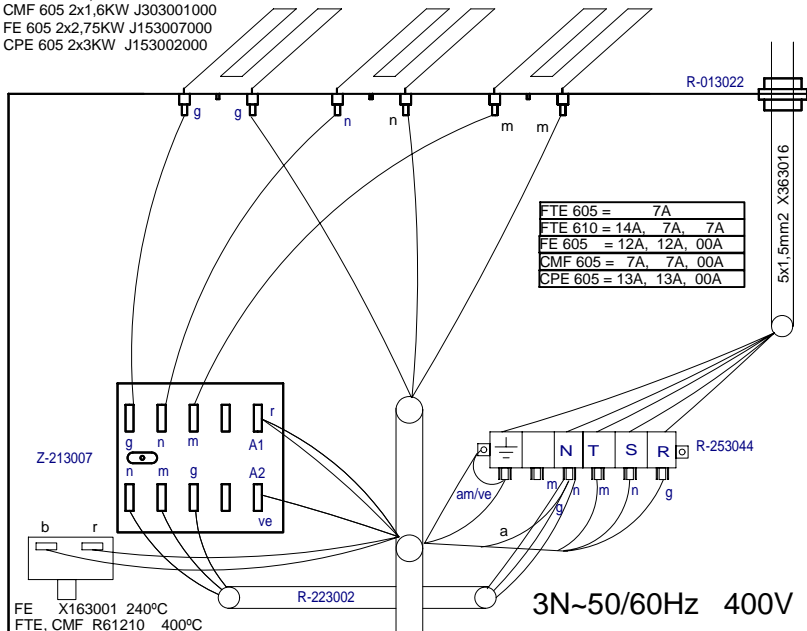

FE 610 x2

FTE 605 FT610,  
 FE 605, CMF 605

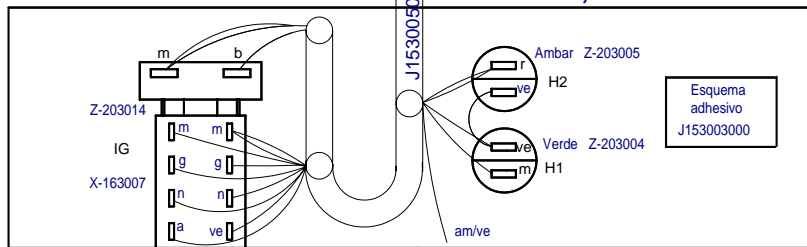

Esquema adhesivo J153003000

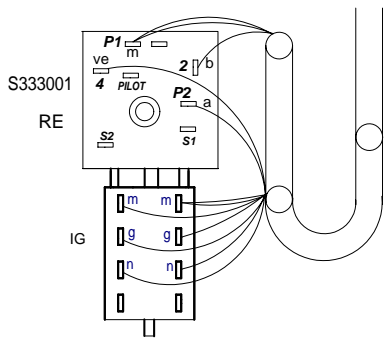

Esquema adhesivo J213001

CPE 605

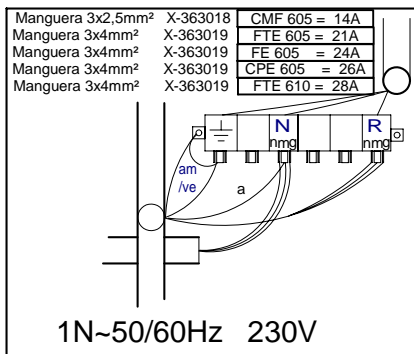

1N-50/60Hz 230V

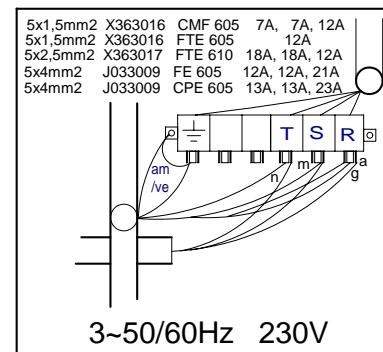
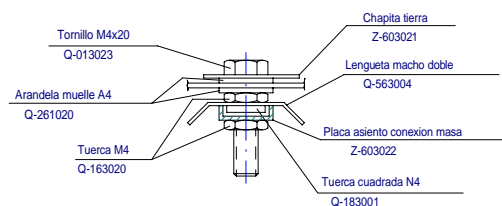

3~50/60Hz 230V

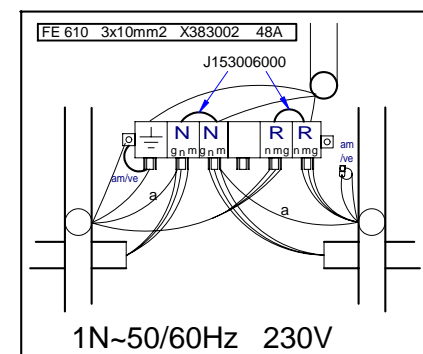

1N-50/60Hz 230V

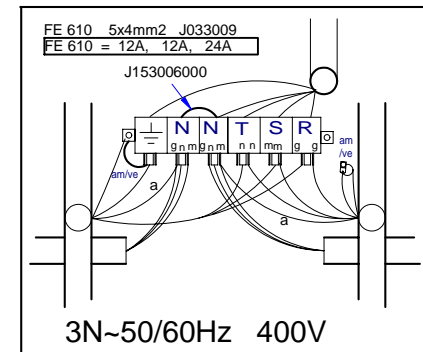

3N-50/60Hz 400V

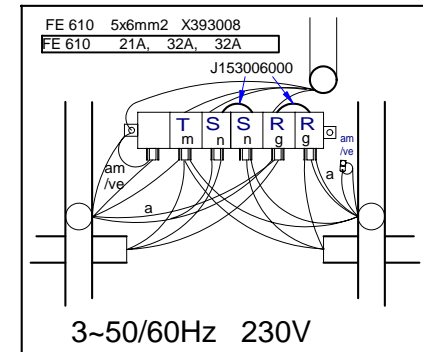

3~50/60Hz 230V

FE 610 Esquema adhesivo J153004000

FE 610

Plano Montaje				J113007000	
Zk./Nº	Pieza	Cant.	Materiala/Material	Klas. zk/Nº Clas.	Gainazal akabera/Tratamiento
Zk./Nº	Aldaketa/Modificaciones		Nork proposatua/Propuesta de	Data/Fecha	Perdoi orokorrak Tolerancias generales
-	-	-	-	-	< 5 ± 0.2   50 ÷ 100 ± 0.8
-	-	-	-	-	5 ÷ 25 ± 0.4   >100 ± 1
-	-	-	-	-	25 ÷ 50 ± 0.6   α ± 1°
Sinadura/Firma		Data/Fecha		Gainazal perdoia Mecanizado superficial	
Marraztua/Dibujado		M.Maïllo 2009-05-13		FAGOR	
Proiektatua/Proyectado		M.Maïllo 2009-05-13		Fagor Industrial, Koop. Elk. Mugatua	
Egiaztatua/Comprobado		I.Alberdi 2009-05-13		-	
Eskala/Escala				Plano Zk./Plano Nº HC-81170	
		COOKING		- Zk. ord. du	
		Plano hau ezin daiteke erabili, ez berrizatu, gure baimenik gabe.		- Zk. gaitik ord.	