

**Hornos Mixtos  
Fours Mixtes  
Combi Ovens  
HeiBluftdämpfer  
Forno Misti**

**Modelos:**

**COE-061**

**COE-101**

**VE-061**

**VE-101**

**VPE-061**

**VPE-101**

*Julio 2009 July*



**Fagor Industrial**

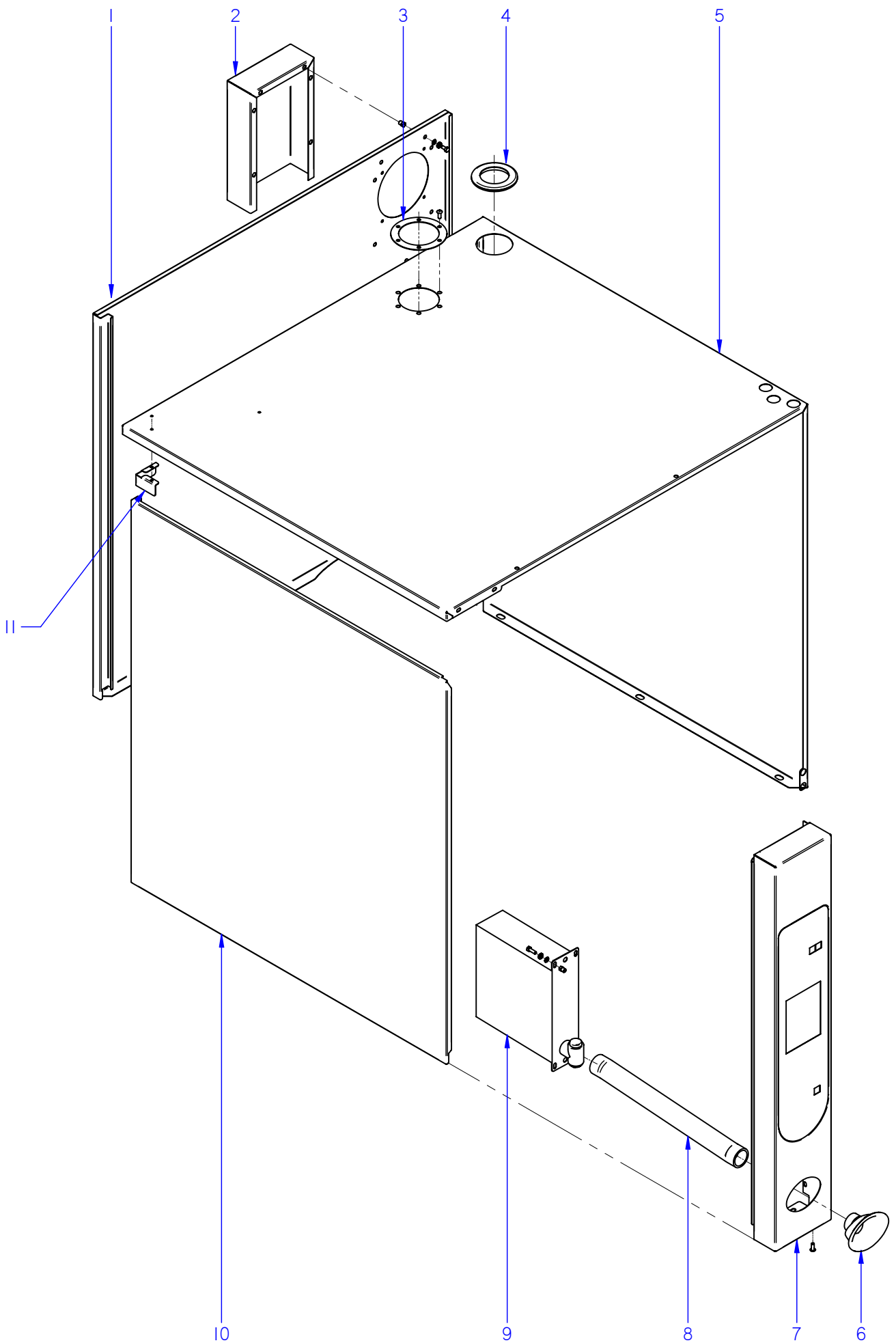

ITEM MARCADO EN COLOR = REPUESTO RECOMENDADO  
 COLOURED ITEM = RECOMMENDED SPARE PART

N plano	Firma	Fecha	Aparato	MUEBLE	Lamina	Fagor Industrial S.Coop. <b>FAGOR</b>
C-2405	<i>name (signature)</i>	2009-07	HORNOS COE; VE; VPE 6/11 - 10/11		1	Oñate

MOD.	HORNOS / OVEN		ZONA	MUEBLE / UNIT						PLANO	C-2405
ITEM	CODIGO	DENOMINACION	TEXTO	COE-061	COE-101	VE-061	VE-101	VPE-061	VPE-101		NOTAS
1	T902802000	PANEL POST EXTERIOR 6-11 EL	REAR EXTERIOR PANEL 6-11 E	1	-	1	-	1	-		
1	T812804000	PANEL POST EXTERIOR 10-11 EL	REAR EXTERIOR PANEL10-11 E	-	1	-	1	-	1		
2	T812806500	CHAPA SEPARACION IPX5	SEPARATION PLATE IPX5	1	1	1	1	1	1		
S/Nº	T812811000	JUNTA IPX5	SEAL IPX5	1	1	1	1	1	1		
3	T325057000	JUNTA BASE CHIMENEA	FLUEPIPE BASE SEAL	1	1	1	1	1	1		
4	R662813000	PASAMUROS CHIMENEA 101003361	FEED THROUGH FLUE PIPE 1010	1	1	1	1	1	1		
5	T902801000	CUERPO EXTERIOR 6/11 ELECT.	EXTERIOR BODY 6/11 ELECT.	1	-	1	-	1	-		
5	T812802000	CUERPO EXTERIOR 10/11 ELECT.	EXTERIOR BODY 10/11 ELECT.	-	1	-	1	-	1		
6	T922801000	EMBELLECEDOR DUCHA	SHOWER TRIM	-	-	1	1	1	1		
7	T902808000	PANEL PORTAMANDO 6-11 HEI	CONTROL PANEL 6-11 HEI	1	-	-	-	-	-		
7	T802802000	PANEL PORTAMANDO 10-11 HEI	CONTROL PANEL 10-11 HEI	-	1	-	-	-	-		
7	T912804000	PANEL PORTAMANDO 6-11 HEM	CONTROL PANEL 6-11 HEM	-	-	1	-	-	-		
7	T812808000	PANEL PORTAMANDO 10-11 HEM	CONTROL PANEL 10-11 HEM	-	-	-	1	-	-		
7	T922804000	PANEL PORTAMANDO 6-11 HEP	CONTROL PANEL 6-11 HEP	-	-	-	-	1	-		
7	T822803000	PANEL PORTAMANDO 10-11 HEP	CONTROL PANEL 10-11 HEP	-	-	-	-	-	1		
	Q221342000	REMACHE EXAGONAL M5	HEXAGONAL RIVET M.5	3	3	3	3	3	3		
S/Nº	T902807000	JUNTA PORTAMANDOS VERT 6/11	CONTROL HOLDER SEAL VERT 1	1	-	1	-	1	-		
S/Nº	T812809000	JUNTA PORTAMANDOS VERT 10/11	CONTROL HOLDER SEAL VERT 1	-	1	-	1	-	1		
S/Nº	T812810000	JUNTA PORTAMANDOS HORZ 10/11	CONTROL HOLDER SEAL HORZ 1	1	1	1	1	1	1		
8	3715700000	TUBO SILICONA ALTA Tº 30,5*37,5	HIGH SILICON PIPE Tº 30.5*37.5	-	-	1	1	1	1		
9	T452809000	DUCHA	SHOWER	-	-	1	1	1	1		
	Q232030000	ARANDELA A5	FLAT WASHER A.5	-	-	4	4	4	4		
	Q242030000	ARANDELA ABANICO A5 A.304	FAN SHAPED WASHER A.5	-	-	4	4	4	4		
	Q012031000	TORNILLO EXAGONAL M5x10 A304	HEXAGONAL SCREW M.5x10	-	-	4	4	4	4		
10	T902803000	PANEL EXTER. IZQUIERDO 6-11 E	REAR LEFT PANEL 6-11 E	1	-	1	-	1	-		
10	T812805000	PANEL EXTER. IZQUIERDO 10-11 E	REAR LEFT PANEL 10-11 E	-	1	-	1	-	1		
	Q302022000	ARANDELA 16X6X1.2 A.304	FLAT WASHER 16x6x1,2	6	6	6	6	6	6		
	Q242040000	ARANDELA ABANICO A6 A.304	FAN SHAPED WASHER A.6	6	6	6	6	6	6		
	Q012042000	TORNILLO EXAGONAL M6X15 A304	HEXAGONAL SCREW M6X15	6	6	6	6	6	6		
11	T922802000	SUJECCION PANELES EXTERIOR.	EXTERIOR PANEL FASTENING.	1	1	1	1	1	1		
	Q152004000	TORNIL. APLASTADO M5X13 A 304	FLAT SCREW M.5x13	2	2	2	2	2	2		

ITEM MARCADO EN COLOR = REPUESTO RECOMENDADO  
 COLOURED ITEM = RECOMMENDED SPARE PART

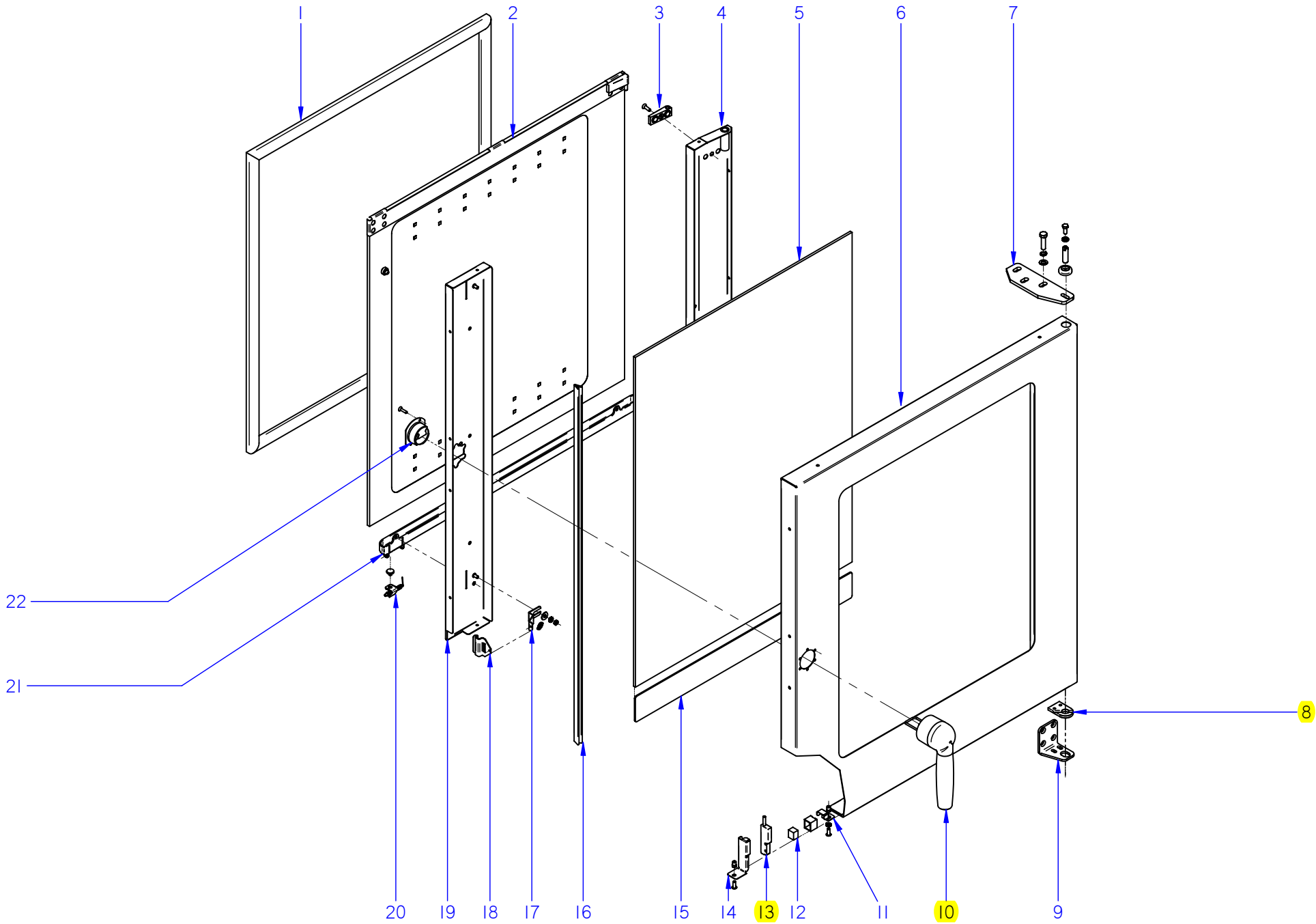

MOD.		HORNOS / OVEN		ZONA	PUERTA / DOOR					PLANO	C-2406
ITEM	CODIGO	DENOMINACION	TEXTO	COE-061	COE-101	VE-061	VE-101	VPE-061	VPE-101		NOTAS
	1100003139	KIT PUERTA 6/11 COMPL.	DOOR 6/11 KIT	1	-	1	-	1	-		
	1100003141	KIT PUERTA 10/11 COMPL.	DOOR 10/11 KIT	-	1	-	1	-	1		
1	R660503000	JUNTA DE PUERTA 6/11	DOOR JOINT 6/11	1	-	1	-	1	-		
1	R670500000	JUNTA DE PUERTA 10/11	DOOR JOINT 10/11	-	1	-	1	-	1		
S/Nº	R660526000	FIJACION JUNTA DE PUERTA 6/11	DOOR SEAL FASTENING 6/11	1	-	1	-	1	-		
S/Nº	R670513000	FIJACION JUNTA DE PUERTA 10/11	DOOR SEAL FASTENING 10/11	1	-	1	-	1	-		
	Q032021000	TORNILLO ALOMADO M4X10	CURVED SCREW M.4x10	24	28	24	28	24	28		
2	1100003130	KIT CRISTAL INTER. 6/11	6/11 INNER GLASS KIT	1	-	1	-	1	-		
2	1100003132	KIT CRISTAL INTER. 10/11	10/11 INNER GLASS KIT	-	1	-	1	-	1		
3	R670615000	BASE DE BISAGRA	HINGE BASE	2	2	2	2	2	2		
	Q042032000	TORNILLO AVELLANADO M5X15	COUNTERSUNK SCREW M.5x15	2	2	2	2	2	2		
4	T900505000	CONTRAPUERTA BISAGRA 6/11	INNER DOOR HINGE 6/11	1	-	1	-	1	-		
4	T840504000	CONTRAPUERTA BISAGRA 10/11	INNER DOOR HINGE 10/11	-	1	-	1	-	1		
	Q221341000	REMACHE EXAGONAL M.4	HEXAGONAL RIVET M.4	1	1	1	1	1	1		
	Q222011000	REMACHE EXAGONAL M.5	HEXAGONAL RIVET M.5	2	2	2	2	2	2		
5	R660610000	CRISTAL EXTERIOR 6/11	EXTERNAL GLASS 6/11	1	-	1	-	1	-		
5	R670627000	CRISTAL EXTERIOR 10/11	EXTERNAL GLASS 10/11	-	1	-	1	-	1		
	R670617000	TOPE CRISTAL INTERIOR	INTERIOR GLASS BUFFER	3	4	3	4	3	4		
6	T900501500	PANEL PUERTA 6/11	DOOR PANEL 6/11	1	-	1	-	1	-		
6	T840501500	PANEL PUERTA 10/11	DOOR PANEL 10/11	-	1	-	1	-	1		
S/Nº	T900508000	CALZO PUERTA	DOOR WEDGE	1	1	1	1	1	1		
	Q242040000	ARANDELA ABANICO A6 A.304	FAN SHAPED WASHER A.6	2	2	2	2	2	2		
	Q012041000	TORNILLO EXAGONAL M6x10	HEXAGONAL BOLT M6x10	2	2	2	2	2	2		
	Q062040000	TORNILLO AVELLANADO M6x16	COUNTERSUNK SCREW M6x16	4	4	4	4	4	4		
7	T130500000	BISAGRA SUPERIOR	UPPER HINGE	1	1	1	1	1	1		
	Q302025000	ARANDELA 8,4X20X1.5	FLAT WASHER 8,4X20X1.5	3	3	3	3	3	3		
	Q261050000	ARANDELA MUELLE A8	SPRING WASHER A8	3	3	3	3	3	3		
	Q012055000	TORNILLO EXAGONAL M8X30	HEXAGONAL BOLT M8X30	3	3	3	3	3	3		
S/Nº	R660534000	EJE SUPERIOR	UPPER SHAFT	1	1	1	1	1	1		
	R662807000	ARANDELA AMARRE	DOOR ANCHORING WASHER	1	1	1	1	1	1		
	Z850519000	RESORTE 06329	SPRING 06329	1	1	1	1	1	1		

MOD.	HORNOS / OVEN		ZONA	PUERTA / DOOR						PLANO	C-2406
ITEM	CODIGO	DENOMINACION	TEXTO	COE-061	COE-101	VE-061	VE-101	VPE-061	VPE-101		NOTAS
8	R660549000	GUIA EJE INFERIOR FUNDIDO	LOWER SHAFT GUIDE	1	1	1	1	1	1		
	Q062040000	TORNILLO AVELLANADO M6X16	COUNTERSUNK SCREW M.6x16	4	4	4	4	4	4		
9	R660551500	BISAGRA INFERIOR PLEGADA	LOWER FOLDER HINGE	1	1	1	1	1	1		
10	T900506000	MANILLA COMPLETA	HANDLE	1	1	1	1	1	1		
	Q042022000	TORNILLO AVELLANADO M4X15	COUNTERSUNK SCREW M.4x15	3	3	3	3	3	3		
11	T130513000	SOPORTE IMAN	MAGNET HOLDER	1	1	1	1	1	1		
	Q222011000	REMACHE EXAGONAL M.5	HEXAGONAL RIVET M.5	1	1	1	1	1	1		
	Q242030000	ARANDELA ABANICO A5 A.304	FAN SHAPED WASHER A.5	1	1	1	1	1	1		
	Q152004000	TORNIL. APLASTADO M5X13 A 304	FLAT SCREW M.5x13	1	1	1	1	1	1		
12	Z200506000	IMAN	MAGNET	1	1	1	1	1	1		
S/Nº	Z200507000	PROTECTOR IMAN	MAGNET PROTECTOR	1	1	1	1	1	1		
13	Z100522000	INTERRUPTOR MAGNETICO AC	MAGNETIC SWITCH AC	1	1	1	1	1	1		
14	T302819000	SOPORTE MICRO PUERTA	DOOR MICRO SWITCH	1	1	1	1	1	1		
	Q152004000	TORNIL. APLASTADO M5X13 A 304	FLAT SCREW M.5x13	1	1	1	1	1	1		
15	T800501000	TOPE CRISTAL EXTERIOR 10/11	EXTERNAL GLASS STOP	1	1	1	1	1	1		
16	3715200000	JUNTA CRISTAL	WINDOW SEAL	2	2	2	2	2	2		
17	R670612000	BASE DE PESTILLO	LATCH BASE	2	2	2	2	2	2		
18	R670613000	PESTILLO	LATCH	2	2	2	2	2	2		
	R660605000	MUELLE TENSOR	LATCH TENSOR SPRING	2	2	2	2	2	2		
	Q302022000	ARANDELA 16X6X1.2 A.304	FLAT WASHER 16x6x1,2	2	2	2	2	2	2		
	Q242030000	ARANDELA ABANICO A5 A.304	FAN SHAPED WASHER A.5	2	2	2	2	2	2		
	Q162030000	TUERCA EXAGONAL M5	HEXAGONAL NUT M.5	2	2	2	2	2	2		
	T900504000	CONTRAP MANILLA COMPL 6/11	COMPLETE HANDLE DOOR 6/11	1	-	1	-	1	-		
19	T840502000	CONTRAP MANILLA COMPL 10/11	COMPLETE HANDLE DOOR 10/11	-	1	-	1	-	1		
	Q221341000	REMACHE EXAGONAL M4	HEXAGONAL RIVET M.4	3	3	3	3	3	3		
20	T840508000	CIERRE RECOGEAGUAS	WATER COLLECTOR COVER	1	1	1	1	1	1		
	T300518000	TAPON CIERRE CANALETA	CAP CHANNEL COVER	1	1	1	1	1	1		
	T840509000	MUELLE CIERRE RECOGEAGUAS	SPRING WATER COLLECTOR CO	1	1	1	1	1	1		
21	T840506000	RECOGEAGUAS PUERTA 6-10/11	DOOR SPRING WATER COLLECT	1	1	1	1	1	1		
	Q042022000	TORNILLO AVELLANADO M4X15	COUNTERSUNK SCREW M.4x15	2	2	2	2	2	2		



ITEM MARCADO EN COLOR = REPUESTO RECOMENDADO  
 COLOURED ITEM = RECOMMENDED SPARE PART

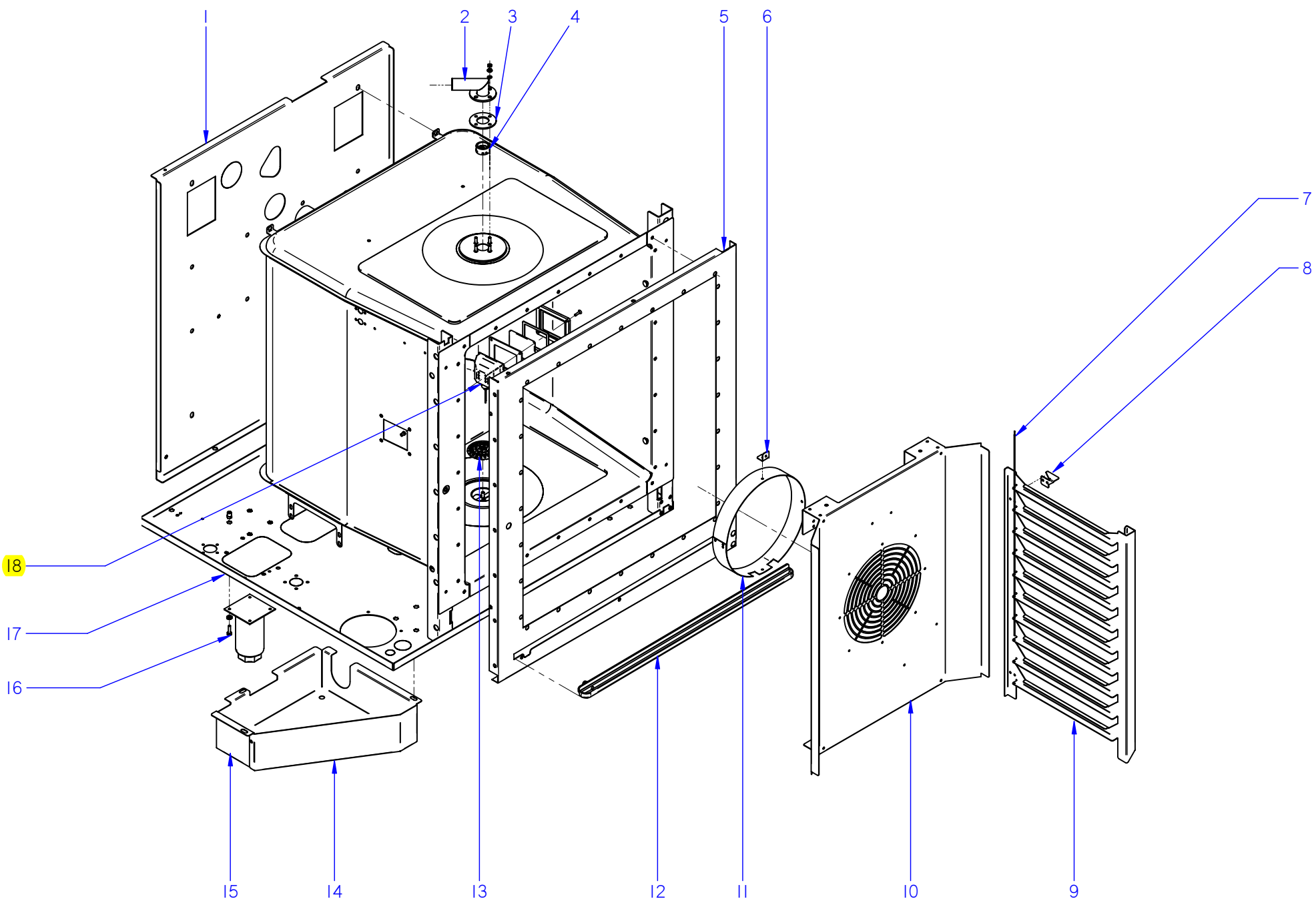



MOD.		HORNOS / OVEN		ZONA		MUEBLE INTERIOR / INTERIOR OVEN				PLANO		C-2407	
ITEM	CODIGO	DENOMINACION	TEXTO	COE-061	COE-101	VE-061	VE-101	VPE-061	VPE-101			NOTAS	
1	T912601000	SOPORTE AISLANTE POST 6-11E	REAR INSULATION SUPPORT	1	-	1	-	1	-				
1	T812611000	SOPORTE AISLANTE POST 10-11E	REAR INSULATION SUPPORT	-	1	-	1	-	1				
	Q221343000	REMACHE EXAGONAL M.6	HEXAGONAL RIVET M.6	3	3	3	3	3	3				
	Q221342000	REMACHE EXAGONAL M.5	HEXAGONAL RIVET M.5	3	3	3	3	3	3				
	Q232040000	ARANDELA A6	FLAT WASHER A.6	11	11	11	11	11	11				
	Q242040000	ARANDELA ABANICO A6 A.304	FAN SHAPED WASHER A.6	11	11	11	11	11	11				
	Q012042000	TORNILLO EXAGONAL M6x15	HEXAGONAL BOLT M6x15	11	11	11	11	11	11				
	Q242030000	ARANDELA ABANICO A5 A.304	FAN SHAPED WASHER A.5	4	4	4	4	4	4				
	Q012031000	TORNILLO EXAGONAL M5X10	HEXAGONAL BOLT M5X10	4	4	4	4	4	4				
2	T820702000	TUBO DIFUSOR LAVADO COMP.	COMPL. WASHING DISPENSER P	-	-	-	-	1	1				
	Q232030000	ARANDELA A5	FLAT WASHER A.5	-	-	-	-	4	4				
	Q242030000	ARANDELA ABANICO A5 A.304	FAN SHAPED WASHER A.5	-	-	-	-	4	4				
	Q162030000	TUERCA EXAGONAL M5	HEXAGONAL NUT M.5	-	-	-	-	4	4				
3	T330744000	CHAPA AMARRE TUBO LAVADO	WASHING PIPE FASTENING PLAT	-	-	-	-	1	1				
4	T360712000	PUNTA DIFUSORA LAVADO	WASHING DISPENSER POINT	-	-	-	-	1	1				
5	T912801000	CHAPA FRONTAL 6-11	FRONT PLATE 6-11	1	-	1	-	1	-				
5	T812801000	PANEL FRONTAL 10-11	FRONT PANEL 10-11	-	1	-	1	-	1				
	Q221342000	REMACHE EXAGONAL M.5	HEXAGONAL RIVET M.5	11	11	11	11	11	11				
	Q232040000	ARANDELA A6	FLAT WASHER A.6	3	3	3	3	3	3				
	Q242040000	ARANDELA ABANICO A6 A.304	FAN SHAPED WASHER A.6	3	3	3	3	3	3				
	Q012042000	TORNILLO EXAGONAL M6x15	HEXAGONAL BOLT M6x15	3	3	3	3	3	3				
	Q222041000	REMACHE EXAGONAL M.4 INOX	HEXAGONAL RIVET M.4 INOX	3	3	3	3	3	3				
6	T302643000	FIJACION SUPLEMENTO	FAN COVER SUPPLEMENT BINDI	4	8	4	8	4	8				
	Q412002000	REMACHE AVINOX Ø4x10MM	TUBULAR RIVET 4x7,5	8	20	8	20	8	18				
7	R662693000	TOPE PORTABANDEJAS 6/11	TRAY HOLDER BUFFER 6/11	2	-	2	-	2	-				
7	R672692000	TOPE PORTABANDEJAS 10/11	TRAY HOLDER BUFFER 10/11	-	2	-	2	-	2				
8	R672691000	ESCUADRA SUJECCION 6-10/11	FASTENING BRACKET	4	4	4	4	4	4				
	Q412002000	REMACHE AVINOX Ø4x10MM	TUBULAR RIVET 4x7,5	8	8	8	8	8	8				

MOD.		HORNOS / OVEN		ZONA		MUEBLE INTERIOR / INTERIOR OVEN				PLANO		C-2407	
ITEM	CODIGO	DENOMINACION	TEXTO	COE-061	COE-101	VE-061	VE-101	VPE-061	VPE-101			NOTAS	
9	R692616000	GUIA DE BANDEJA DCHA.6/11	RIGHT TRAY GUIDE 6/11	1	-	1	-	1	-				
9	R672612000	GUIA DE BANDEJA DCHA.10/11	RIGHT TRAY GUIDE 10/11	-	1	-	1	-	1				
S/Nº	R692617000	GUIA DE BANDEJA IZDA.6/11	LEFT TRAY GUIDE 6/11	1	-	1	-	1	-				
S/Nº	R672613000	GUIA DE BANDEJA IZDA.10/11	LEFT TRAY GUIDE 10/11	-	1	-	1	-	1				
10	T902603000	CUBREVENTILADOR 6/11 ELECT.	FAN COVER 6/11 ELECT.	1	-	1	-	1	-				
10	T802605000	CUBREVENTILADOR 10/11 ELECT.	FAN COVER 10/11 ELECT.	-	1	-	1	-	1				
11	T132644000	2011G SUPL. CUBREVENTILADOR	2011G SUPPL. FAN COVER	1	1	1	1	1	1				
12	T842809000	RECOGEAGUAS PLAST 6-10/11	PLAST SPRING WATER COLLE.	1	1	1	1	1	1				
	Q242040000	ARANDELA ABANICO A6 A.304	FAN SHAPED WASHER A.6	3	3	3	3	3	3				
	Q032021000	TORNILLO ALOMADO M4x10	CURVED SCREW M.4x10	3	3	3	3	3	3				
13	T302695000	FILTRO DESAGÜE	DRAINAGE FILTER	1	1	1	1	1	1				
14	T820706000	TAPA CAJA CUBRE SIST LAVADO	COVER WASHING SYSTEM BOX	-	-	-	-	1	1				
	Q152004000	TORNILLO APLAST. M5X13 A 304	FLAT SCREW M.5x13	-	-	-	-	2	2				
15	T820705000	CAJA CUBRE SISTEMA LAVADO	CLEANING SYSTEM BOX	-	-	-	-	1	1				
	Q221342000	REMACHE EXAGONAL M.5	HEXAGONAL RIVET M.5	-	-	-	-	2	2				
	Q232030000	ARANDELA A5	FLAT WASHER A.5	-	-	-	-	3	3				
	Q242030000	ARANDELA ABANICO A5 A.304	FAN SHAPED WASHER A.5	-	-	-	-	3	3				
	Q012031000	TORNILLO EXAGONAL M5X10	HEXAGONAL BOLT M5X10	-	-	-	-	3	3				
16	X260151000	PATA REGULABLE	REGULABLE LEG	4	4	4	4	4	4				
	Q232040000	ARANDELA A6	FLAT WASHER A.6	16	16	16	16	16	16				
	Q242040000	ARANDELA ABANICO A6 A.304	FAN SHAPED WASHER A.6	16	16	16	16	16	16				
	Q012043000	TORNILLO EXAGONAL M6x20	HEXAGONAL BOLT M6x20	16	16	16	16	16	16				
17	T912802000	BASE HORNO 6/11 10/11	OVEN BASE 6/11 10/11	1	1	1	1	1	1				
	Q221343000	REMACHE EXAGONAL M.6	HEXAGONAL RIVET M.6	30	30	30	30	30	30				
	Q221342000	REMACHE EXAGONAL M.5	HEXAGONAL RIVET M.5	12	12	12	12	12	12				



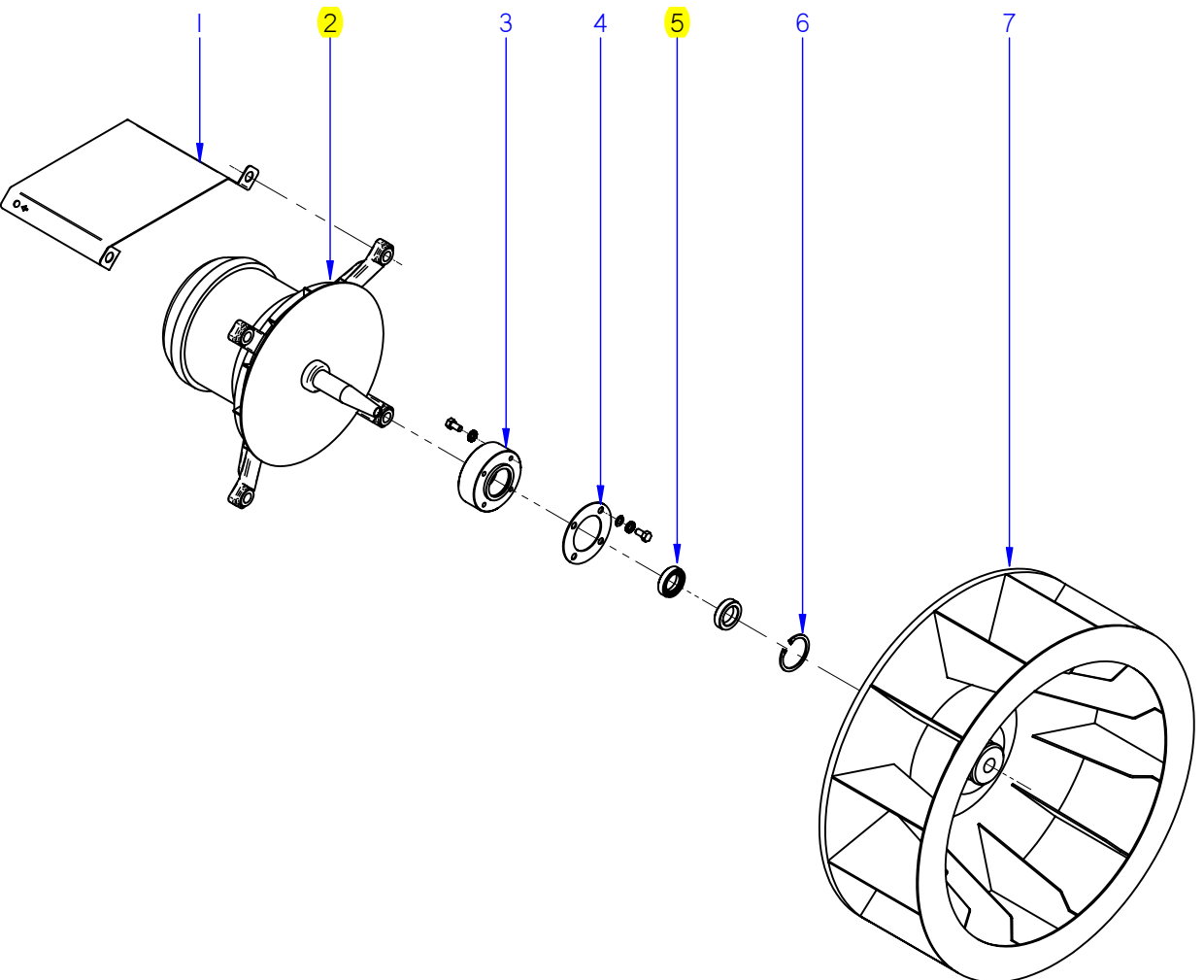
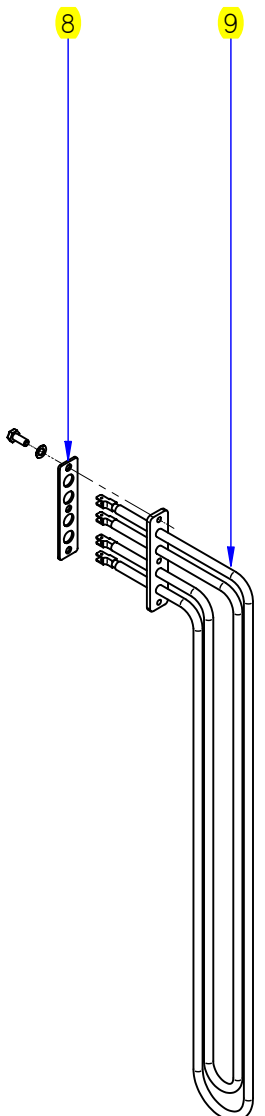

ITEM MARCADO EN COLOR = REPUESTO RECOMENDADO  
COLOURED ITEM = RECOMMENDED SPARE PART

N plano	Firma	Fecha	Aparato	TURQUINA	Lamina	Fagor Industrial S. Coop. <b>FAGOR</b> Omate
C-2408		2009-07	HORNOS COE; VE; VPE 6/11 - 10/11		4	



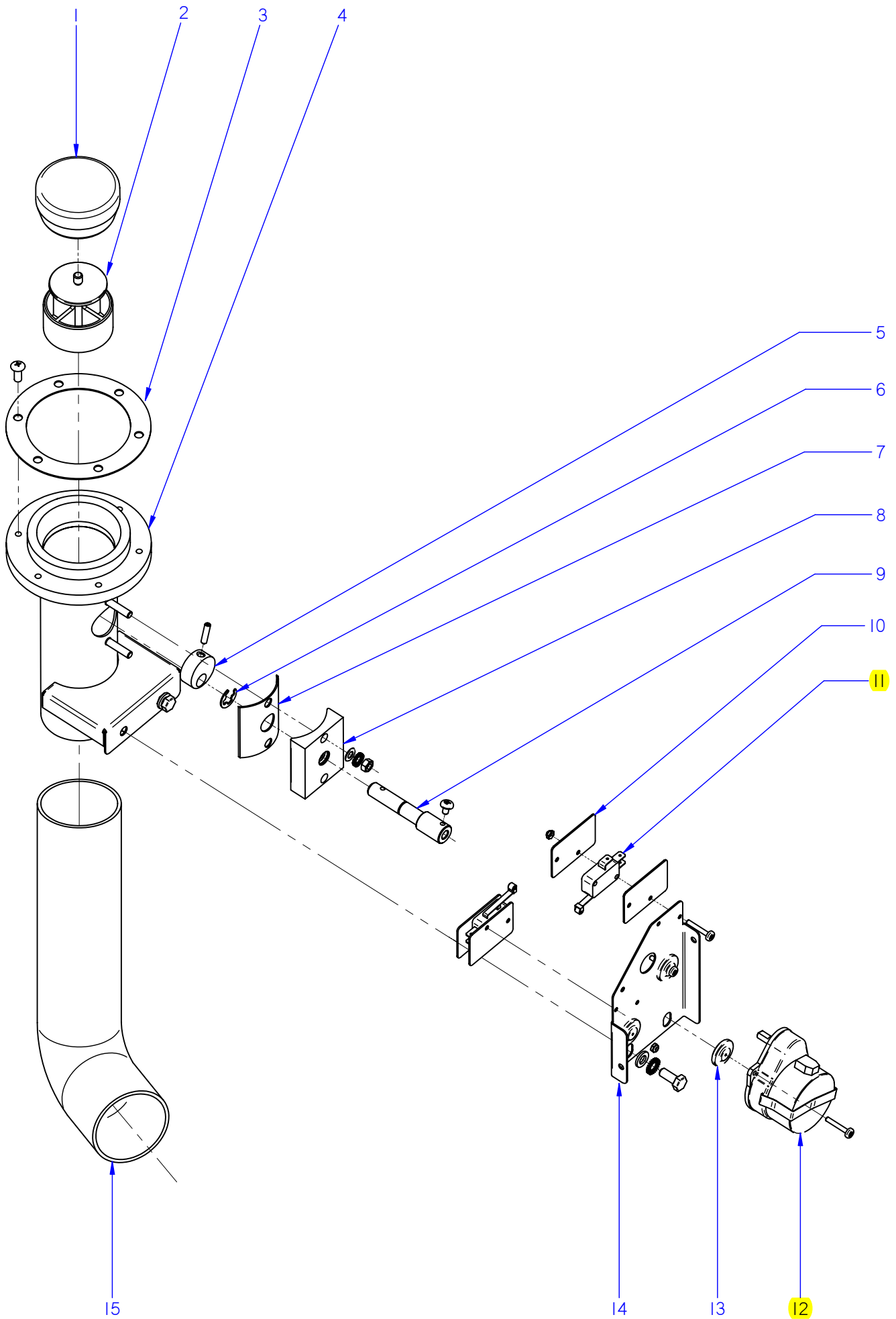

ITEM MARCADO EN COLOR = REPUESTO RECOMENDADO  
 COLOURED ITEM = RECOMMENDED SPARE PART

N plano	Firma	Fecha	Aparato	CHIMENEA	Lamina	Fagor Industrial S.Coop. <b>FAGOR</b>
C-2409	<i>[Signature]</i>	2009-07	HORNOS COE; VE; VPE 6/11 - 10/11		5	Oñate

MOD.		HORNOS / OVEN		ZONA		CHIMENEA / FLUEPIPE				PLANO		C-2409
ITEM	CODIGO	DENOMINACION	TEXTO	COE-061	COE-101	VE-061	VE-101	VPE-061	VPE-101		NOTAS	
1	T325055000	RETENCION DE VAPORES	CLOSE CHIMNEY	1	1	1	1	1	1			
2	T815014000	GUIA RETENCION VAPORES	STEAM RETAINER GUIDE	1	1	1	1	1	1			
3	T325057000	JUNTA BASE CHIMENEA	FLUEPIPE BASE SEAL	1	1	1	1	1	1			
	Q152004000	TORNIL. APLASTADO M5X13 A 304	FLAT SCREW M.5x13	6	6	6	6	6	6			
4	T915015000	CONJUNTO CHIMENEA 6/11	COMPLETE CHIMNEY 6/11	1	-	1	-	1	-			
4	T815006000	CONJUNTO CHIMENEA	COMPLETE CHIMNEY	-	1	-	1	-	1			
	Q221343000	REMACHE EXAGONAL M.6	HEXAGONAL RIVET M.6	2	2	2	2	2	2			
5	T325032000	LEVA EJE CHIMENEA	FLUEPIPE SHAFT CAM	1	1	1	1	1	1			
	Q132045000	VARILLA ROSCADA M4X16	THREADED ROD M4X16	1	1	1	1	1	1			
6	Q271006000	ARANDELA DE SEGURIDAD Ø8	SAFETY WASHER Ø8	1	1	1	1	1	1			
7	T325030000	JUNTA EJE CHIMENEA	FLUEPIPE SHAFT SEAL	1	1	1	1	1	1			
8	T325029000	GUIA EJE CHIMENEA	FLUEPIPE SHAFT GUIDE	1	1	1	1	1	1			
	Q232030000	ARANDELA A5	FLAT WASHER A.5	2	2	2	2	2	2			
	Q242030000	ARANDELA ABANICO A5 A.304	FAN SHAPED WASHER A.5	2	2	2	2	2	2			
	Q162030000	TUERCA EXAGONAL M5	HEXAGONAL NUT M.5	2	2	2	2	2	2			
9	T815010000	EJE CHIMENEA ELECTRICA	ELECTRIC FLUEPIPE SHAFT	1	1	1	1	1	1			
	Q151320000	TORNILLO ALOMADO M4X6 ZINC.	CURVED SCREW M4X6 ZINC.	1	1	1	1	1	1			
10	R010535000	PLACA SEPARADORA	SPACER PLATE	4	4	4	4	4	4			
	Q032013000	TORNILLO ALOMADO M3X20	CURVED SCREW M3X20	4	4	4	4	4	4			
	Q221350000	TUERCA AUTOBLOCANTE M3	SELF-LOCKING NUT M3	4	4	4	4	4	4			
11	R010534000	INTERRUPTOR PUERTA	DOOR SWITCH	2	2	2	2	2	2			
12	T323010000	MOTOR CHIMENEA	FLUEPIPE MOTOR	1	1	1	1	1	1			
13	Q308006000	ARANDELA DUBO Ø 4	WASHER DUBO Ø 4	3	3	3	3	3	3			
14	T815009000	ESCUA. AMARRE MOTOR CHIMEN.	FLUEPIPE MOTOR FASTENING B	1	1	1	1	1	1			
	Q232040000	ARANDELA A6	FLAT WASHER A.6	2	2	2	2	2	2			
	Q242040000	ARANDELA ABANICO A6 A.304	FAN SHAPED WASHER A.6	2	2	2	2	2	2			
	Q012042000	TORNILLO EXAGONAL M6X15 A304	HEXAGONAL SCREW M6X15	2	2	2	2	2	2			
15	T722608000	TUBO FLEXIBLE Ø53X360	FLEXIBLE TUBE Ø53X360	-	1	1	1	1	1			
	Q881307000	ABRAZADERA 40*60	CLAMP 40*60	-	2	2	2	2	2			

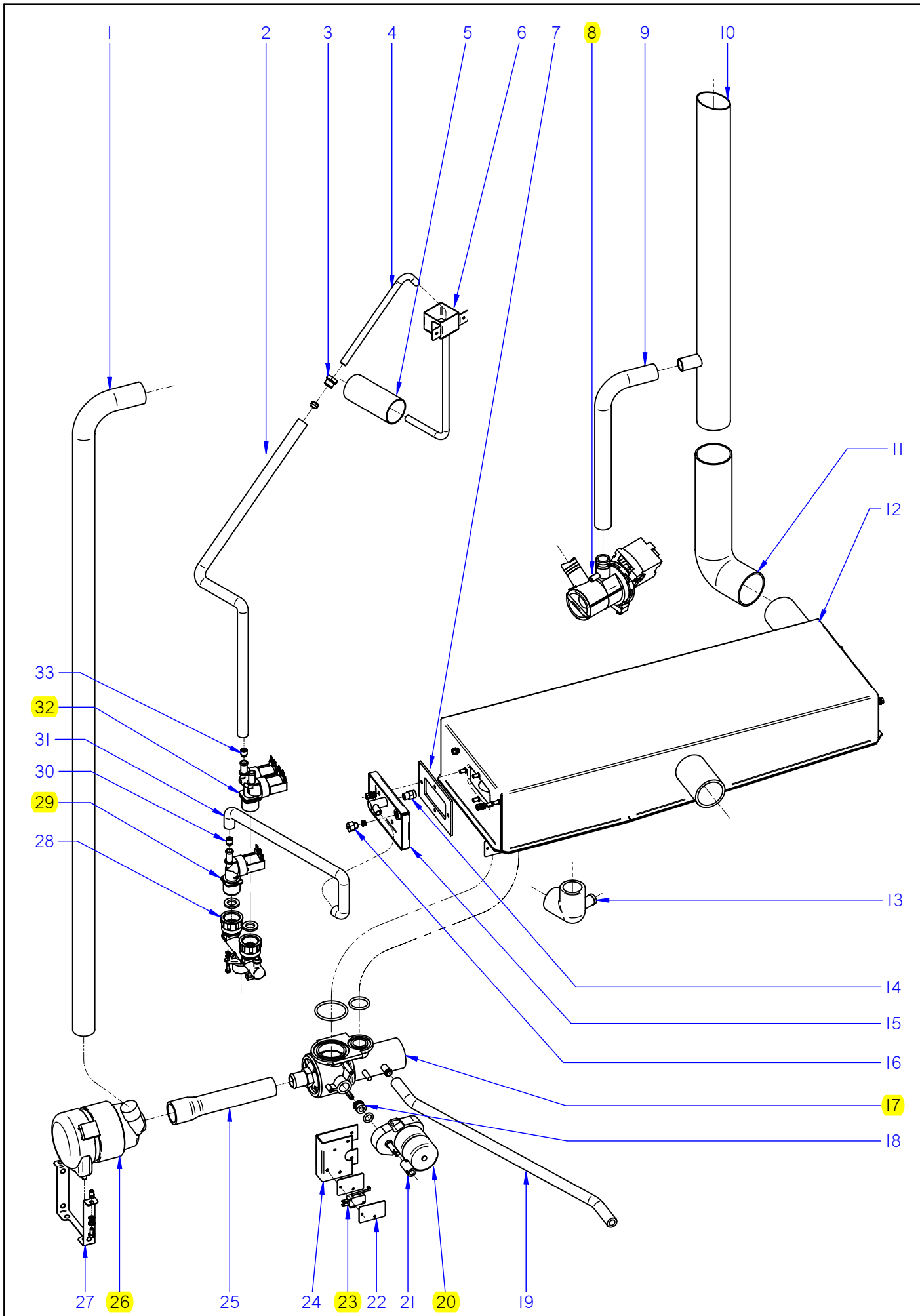

ITEM MARCADO EN COLOR = REPUESTO RECOMENDADO  
 COLOURED ITEM = RECOMMENDED SPARE PART

N plano	Firma	Fecha	Aparato	CONDUCCIONES DE AGUA	Lamina	Fagor Industrial S.Coop. <b>FAGOR</b>
C-2410	<i>[Signature]</i>	2009-07	HORNOS COE; VE; VPE 6/11 - 10/11		6	Oñate



MOD.		HORNOS / OVEN		ZONA		CONDUCCIONES DE AGUA / WATER PIPES				PLANO		C-2410	
ITEM	CODIGO	DENOMINACION	TEXTO	COE-061	COE-101	VE-061	VE-101	VPE-061	VPE-101			NOTAS	
1	3716000000	TUBO SILICONA T° Ø 35*27	HIGH SILICON PIPE T° Ø 35*27	-	-	-	-	1	1				
	Q881305000	ABRAZADERA 25-40	CLAMP 25-40	-	-	-	-	2	2				
2	3676900000	T. GOMA NEGRA Ø17*10 INYECT.	BLACK RUBBER PIPE Ø17*10	1	1	1	1	1	1				
	Q881302000	ABRAZADERA 12*20	CLAMP 12-20	2	2	2	2	2	2				
3	R695003000	MANGÜITO CIERRE	CLOSING SLEEVE	1	1	1	1	1	1				
	R695004000	BICONO	BICONE	1	1	1	1	1	1				
4	R095010000	TUBO ENTRADA INYECTOR	INJECTOR PIPE	1	1	-	-	-	-				
4	R695033000	TUBO INYECTOR 6/11	INJECTOR PIPE	-	-	1	1	1	1				
5	R665025000	DISTRIBUIDOR INYECTOR	INJECTOR DISTRIBUTOR	1	1	-	-	-	-				
6	T905004000	INYECTOR COMPLETO HEI 6/11	COMPLETE INJECTOR HEI 6/11	1	-	-	-	-	-				
6	T805002000	INYECTOR COMPLETO HEI 10/11	COMPLETE INJECTOR HEI 10/11	-	1	-	-	-	-				
7	T325066000	JUNTA FIJACION SONDA	PROBE FASTENING SEAL	1	1	1	1	1	1				
	Q232030000	ARANDELA A5	FLAT WASHER A.5	8	8	8	8	8	8				
	Q242030000	ARANDELA ABANICO A5 A.304	FAN SHAPED WASHER A.5	8	8	8	8	8	8				
	Q162030000	TUERCA EXAGONAL M5	HEXAGONAL NUT M.5	8	8	8	8	8	8				
8	Z220901000	BOMBA DESAGÜE 30W	DRAINAGE PUMP 30W	-	-	1	1	1	1				
9	3715900000	TUBO SILICONA T° Ø 26*18	HIGH SILICON PIPE T° Ø 26*18	-	-	1	1	1	1				
	Q901311000	ABRAZADERA ELASTICA 26,7*28,1	ELAST. CLAMP 26,7*28,1	-	-	2	2	2	2				
10	T905001000	CHIMENEA COMPLET HEI 6/11	COMPLET FLUEPIPE HEI 6/11	1	-	-	-	-	-				
10	T805001000	CHIMENEA COMPLET HEI 10/11	COMPLET FLUEPIPE HEI 10/11	-	1	-	-	-	-				
10	T915011000	CHIMENEA COMPLET HEM-P 6/11	COMPLET FLUEPIPE HEM-P 6/11	-	-	1	-	1	-				
10	T815011000	CHIMENEA COMPLET HEM-P 10/11	COMPLET FLUEPIPE HEM/P 10/11	-	-	-	1	-	1				
11	T722608000	TUBO FLEXIBLE Ø53X360	FLEXIBLE TUBE Ø53X360	1	1	1	1	1	1				
	Q881307000	ABRAZADERA 40*60	CLAMP 40*60	2	2	2	2	2	2				
12	T915005000	CAJA DESAGÜE LAVADO	COM. DRAINAGE BOX	1	1	1	1	-	-				
12	T825001000	CAJA DESAGÜE LAVADO 6/10/11	COM. DRAINAGE BOX 6/10/11	-	-	-	-	1	1				
13	R665080000	CODO DESAGUE	DRAINAGE L-BEND	1	1	1	1	-	-				
S/Nº	T815001000	CONDUCCIÓN DESAGÜE 6-10/11 E	DRAINAGE DUCT 6-10/11 E	1	1	1	1	-	-				
14	T115086000	TOBERA 1/8	NOZZLE 1/8	1	1	1	1	1	1				
15	T325075000	FIJACION SONDA CONDENSADOR	COMPLET. PROBE FASTENING	1	1	1	1	1	1				

MOD.		HORNOS / OVEN		ZONA		CONDUCCIONES DE AGUA / WATER PIPES				PLANO		C-2410	
ITEM	CODIGO	DENOMINACION	TEXTO	COE-061	COE-101	VE-061	VE-101	VPE-061	VPE-101			NOTAS	
16	R662629000	RACORD CIERRE SONDA	PROBE CLOSING ADAPTOR	1	1	1	1	1	1				
	R662652000	BICONO CIERRE SONDA	PROBE CLOSING BICONE	1	1	1	1	1	1				
17	T330723000	CUERPO VALVULA COMPLETO	COMPLETE VALVE BODY	-	-	-	-	1	1				
	Q307080000	JUNTA TORICA Ø52X3,5	O-RING Ø52X3.5	-	-	-	-	1	1				
	Q307079000	JUNTA TORICA Ø33x3,5	O-RING Ø33x3.5	-	-	-	-	1	1				
18	T330707000	PUNTA ACOPLE MOTOR A VALVUL	CONN. POINT MOTOR TO VALVE	-	-	-	-	1	1				
	Q307084000	JUNTA TORICA Ø18X3.5	O-RING Ø18X3.5	-	-	-	-	1	1				
19	3676900000	TUBO GOMA NEGRA Ø17*10	BLACK RUBBER PIPE Ø17*10	-	-	-	-	1	1				
	Q881302000	ABRAZADERA 12*20	CLAMP 12-20	-	-	-	-	2	2				
20	T330711000	MOTOR VALVULA	VALVE MOTOR	-	-	-	-	1	1				
	Q042022000	TORNILLO AVELLANADO M4X15	COUNTERSUNK SCREW M.4x15	-	-	-	-	2	2				
21	T330733000	CASQUILLO MOTOR MICRO	MICRO MOTOR BUSHING	-	-	-	-	1	1				
	Q151320000	TORNILLO ALOMADO M4X6 H.ZIN.	CURVED SCREW M4X6 H.ZIN.	-	-	-	-	2	2				
	Q371026000	MANGUITO SUJEC. 4X14 DIN1481	HOSE FASTENING 4X14 DIN1481	-	-	-	-	1	1				
	Q052032000	TORNILLO ALLEN M.5x15(+)	ALLEN HEAD SCREW M.5x15(+)	-	-	-	-	2	2				
22	R010535000	PLACA SEPARADORA	SPACER PLATE	-	-	-	-	4	4				
	Q032013000	TORNILLO ALOMADO M3X20	CURVED SCREW M3X20	-	-	-	-	4	4				
	Q221350000	TUERCA AUTOBLOCANTE M3	SELF-LOCKING NUT M3	-	-	-	-	4	4				
23	R010534000	INTERRUPTOR PUERTA	DOOR SWITCH	-	-	-	-	2	2				
24	T330713000	CHAPA SUJECCION MICROS	FASTENING PLATE MICROS	-	-	-	-	1	1				
25	T360719000	GOMA VALVULA BOMBA GAS	PUMP VALVE RUBBER GAZ	-	-	-	-	1	1				
	Q881304000	ABRAZADERA 20-32	CLAMP 20-32	-	-	-	-	1	1				
	Q881305000	ABRAZADERA 25-40	CLAMP 25-40	-	-	-	-	1	1				
26	Z258962000	MOTOBOMBA ACLARADO	MOTOR-PUMP	-	-	-	-	1	1				
27	T820701000	SOPORTE MOTOBOMBA 6-10/11	MOTOR PUMP SUPPORT 6-10/11	-	-	-	-	1	1				
	Q232030000	ARANDELA A5	FLAT WASHER A.5	-	-	-	-	2	2				
	Q242030000	ARANDELA ABANICO A5 A.304	FAN SHAPED WASHER A.5	-	-	-	-	2	2				
	Q012032000	TORNILLO EXAGONAL M5x15 A304	HEXAGONAL SCREW M.5x15	-	-	-	-	2	2				



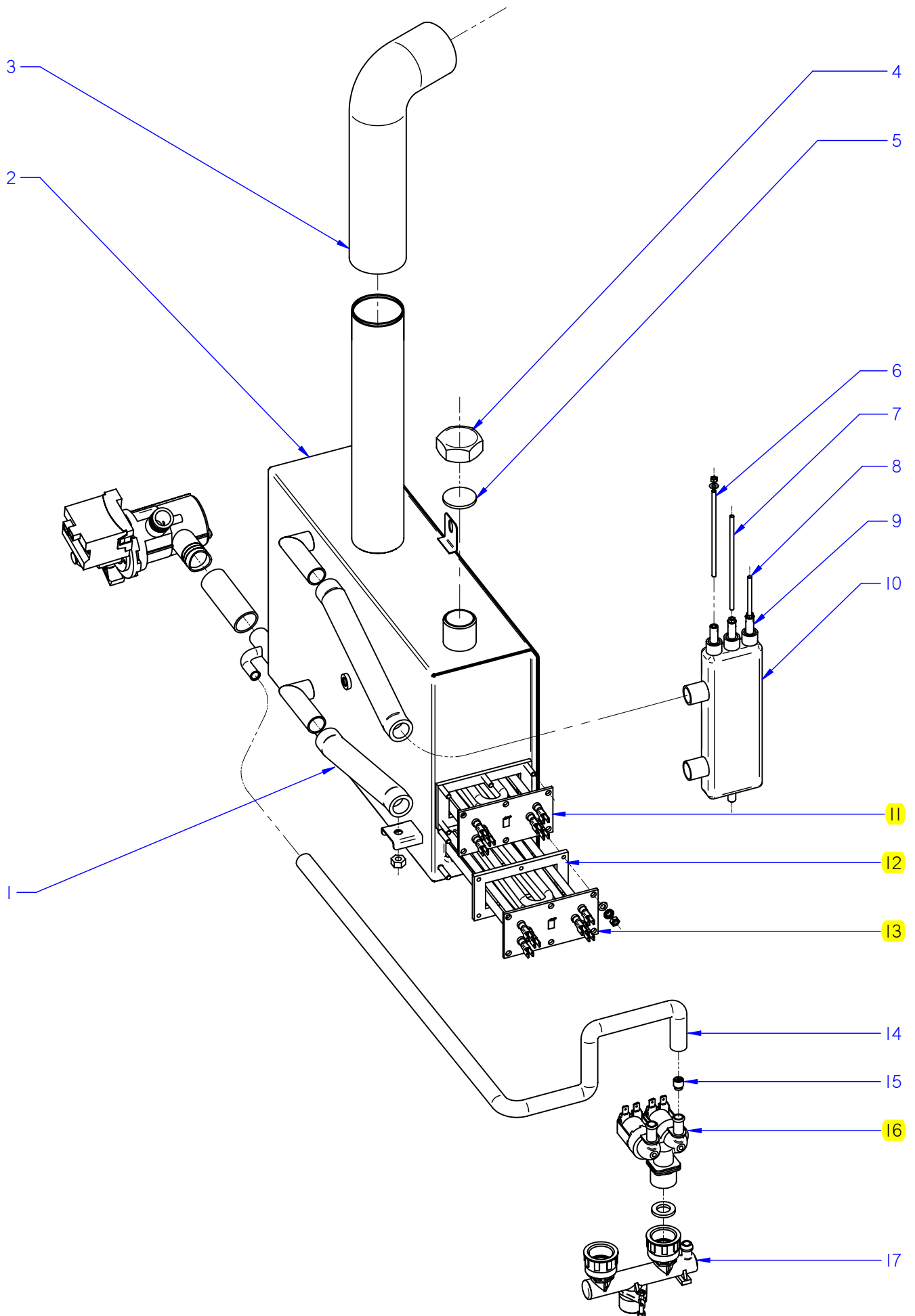

ITEM MARCADO EN COLOR = REPUESTO RECOMENDADO  
 COLOURED ITEM = RECOMMENDED SPARE PART

N plano	Firma	Fecha	Aparato	CIRCUITO DE VAPOR	Lamina	Fagor Industrial S.Coop. <b>FAGOR</b>
C-2411	<i>name Benjo</i>	2009-07	HORNOS VE; VPE 6/11 - 10/11	7	Oñate	

MOD.	HORNOS / OVEN		ZONA	CIRCUITO DE VAPOR / STEAM CIRCUIT				PLANO	C-2411
ITEM	CODIGO	DENOMINACION	TEXTO	VE-061	VE-101	VPE-061	VPE-101		NOTAS
1	3715900000	TUBO SILICONA Tº Ø 26*18	HIGH SILICON PIPE Tº Ø 26*18	3	3	3	3		
	Q901311000	ABRAZADERA ELASTICA 26,7*28,1	ELAST. CLAMP 26,7*28,1	6	6	6	6		
2	1100003140	KIT GENERADOR VAPOR 6/11	STEAM GENERATOR 6/11 KIT	1	-	1	-		
2	1100003142	KIT GENERADOR VAPOR 10-20/11	STEAM GENERATOR 10-20 KIT	-	1	-	1		
3	T722608000	TUBO FLEXIBLE Ø53X360	FLEXIBLE TUBE Ø53X360	1	1	1	1		
	Q881307000	ABRAZADERA 40*60	CLAMP 40*60	2	2	2	2		
4	R015010000	TUERCA TAPON 1"	PLUG NUT 1"	1	1	1	1		
5	R015011000	ARANDELA Ø32	WASHER Ø32	1	1	1	1		
6	R345060000	ELECTRODO ALTO	HIGH LEVEL ELECTRODE	1	1	1	1		
7	R345063000	ELECTRODO BAJO	LOW LEVEL ELECTRODE	1	1	1	1		
8	R345064000	ELECTRODO DE MASA	EARTH ELECTRODE	1	1	1	1		
	Q232020000	ARANDELA A4	FLAT WASHER A.4	3	3	3	3		
	Q162020000	TUERCA EXAGONAL M4	HEXAGONAL NUT M.4º	3	3	3	3		
9	R345069000	GUIA AISLANTE	INSULATION GUIDE	3	3	3	3		
10	T325077000	BOTE DE NIVELES	LEVELS VESSEL	1	1	1	1		
	Q228051000	TUERCA EXAGONAL M8 PLASTIC	HEXAGONAL NUT M8 PLASTIC	1	1	1	1		
11	R143033000	RESISTENCIA 3x3000W 230V	RESISTOR 3x3000W 230V	1	1	1	1		
12	R145012000	JUNTA CIERRE RESISTENCIAS	RESISTOR SEAL	1	2	1	2		
	Q232030000	ARANDELA A5	FLAT WASHER A.5	6	12	6	12		
	Q242030000	ARANDELA ABANICO A5 A.304	FAN SHAPED WASHER A.5	6	12	6	12		
	Q163030000	TUERCA EXAGONAL M5 LATON	HEXAGONAL NUT M5	6	12	6	12		
13	R143000000	RESISTENCIA 3x3000W	RESISTOR 3x3000W	-	1	-	1		
14	3676900000	T. GOMA NEGRA Ø17*10	BLACK RUBBER PIPE Ø17*10	1	1	1	1		
	Q881302000	ABRAZADERA 12*20	CLAMP 12-20	2	2	2	2		
15	Z601156000	REGULADOR 8L RO 254.034	REGULATOR 8L RED 254.034	1	1	1	1		
16	P255001000	ELECTROVALVULA DOBLE	DOUBLE SOLENOID VALVE	1	1	1	1		
17	T325063000	ENTRADA DE AGUA COMPLETA	COMPLETE WATER INLET	1	1	1	1		
	Q307031000	JUNTA TUBO 14X24X3	JOINT 14X24X3	2	2	2	2		
	Q012021000	TORNILLO EXAGONAL M4x10 A304	HEXAGONAL BOLT M4x10 A304	2	2	2	2		
	Q242010000	ARANDELA ABANICO A3 A.304	FAN SHAPED WASHER A.3	2	2	2	2		
	Q162020000	TUERCA EXAGONAL M4	HEXAGONAL NUT M.4º	2	2	2	2		

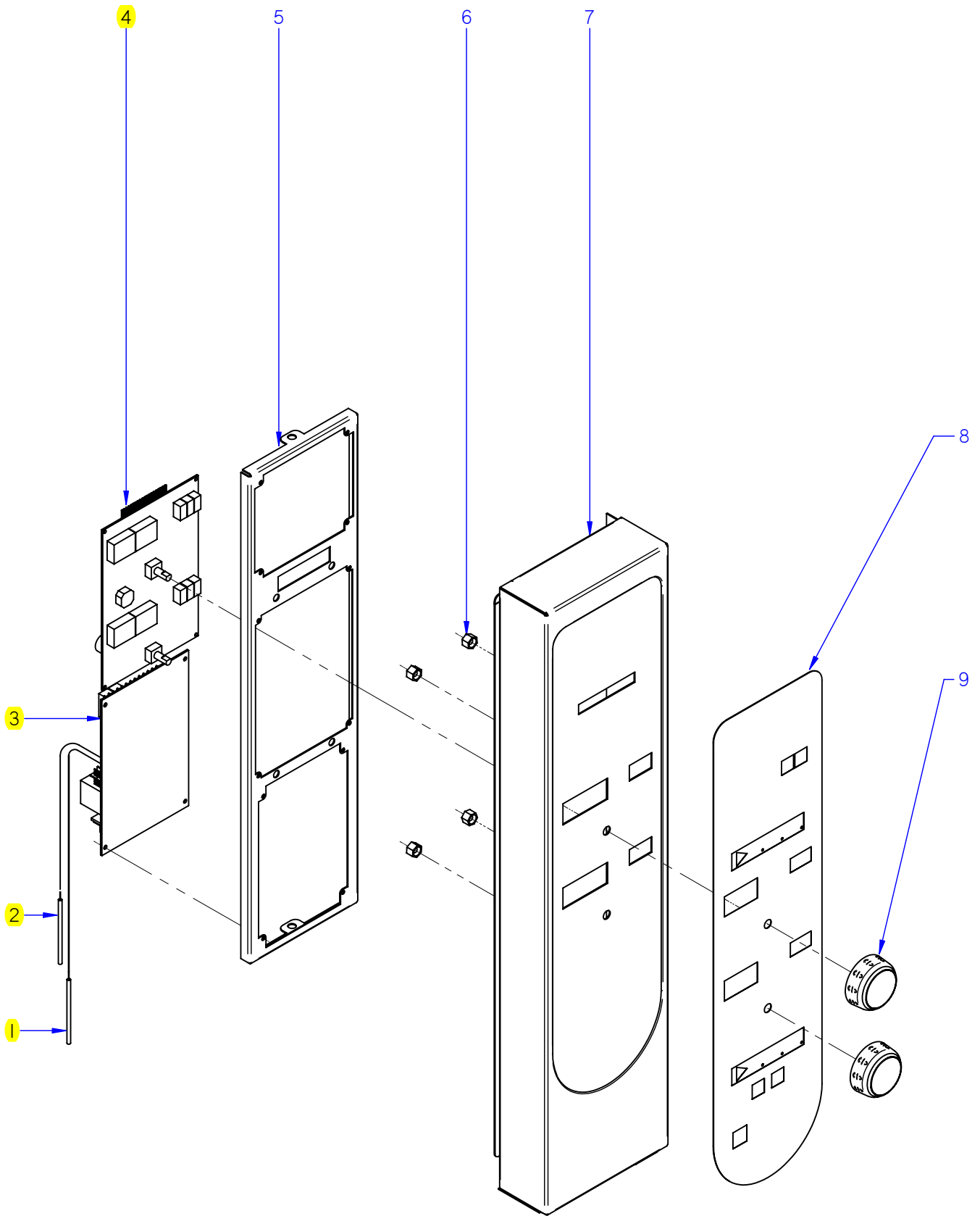

ITEM MARCADO EN COLOR = REPUESTO RECOMENDADO  
 COLOURED ITEM = RECOMMENDED SPARE PART

N plano	Firma	Fecha	Aparato	CONJUNTO ELECTRICO PORTAMANDOS	Lamina	Fagor Industrial S.Coop. <b>FAGOR</b>
C-2412	<i>[Signature]</i>	2009-07	HORNOS COE 6/11; 10/11	8	Oñate	



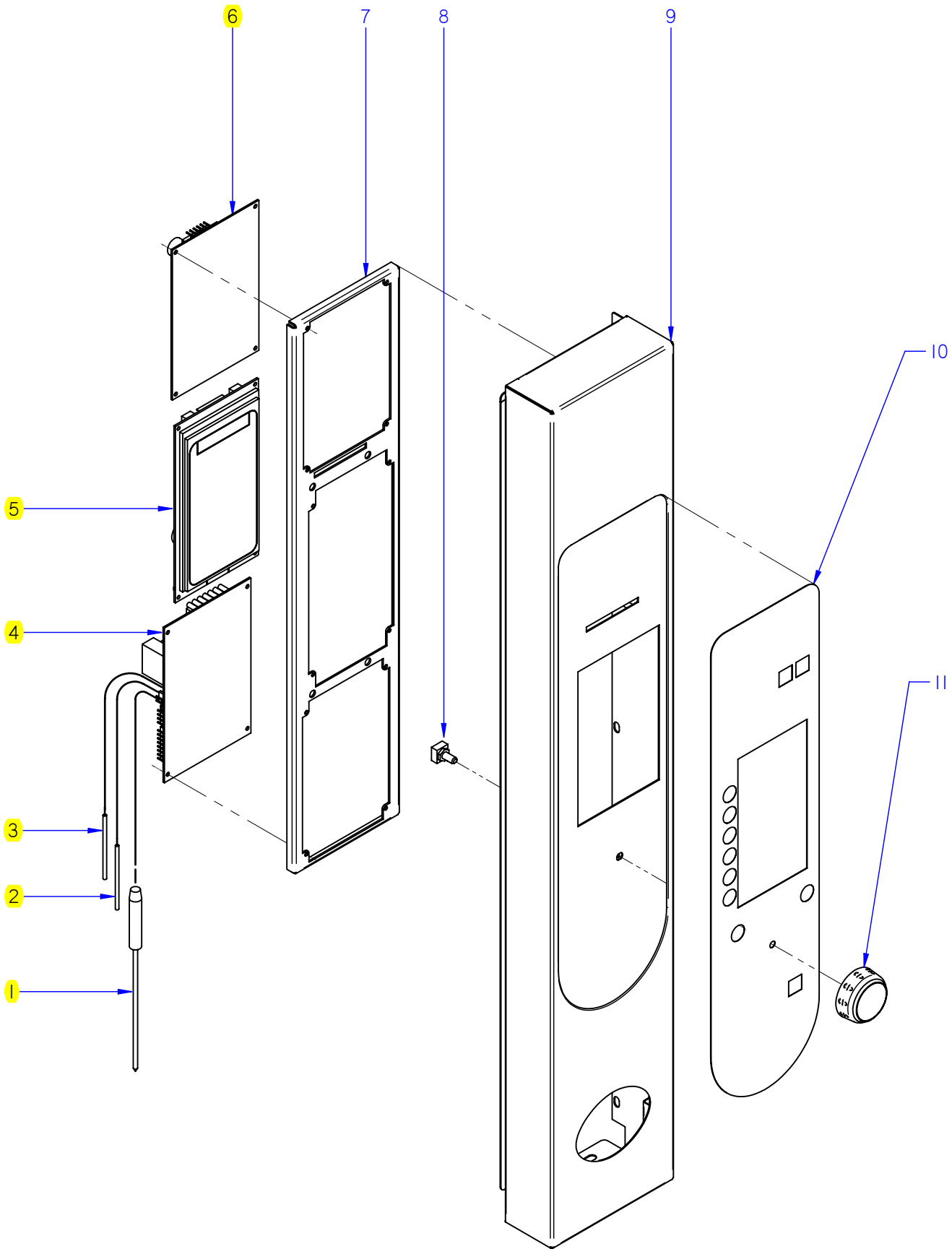

ITEM MARCADO EN COLOR = REPUESTO RECOMENDADO  
 COLOURED ITEM = RECOMMENDED SPARE PART

N plano	Firma	Fecha	Aparato	Lamina	Fagor Industrial S.Coop. <b>FAGOR</b>
C-2413	<i>[Signature]</i>	2009-07	CONJUNTO ELECTRICO PORTAMANDOS HORNOS VE 6/11; 10/11	9	Oñate





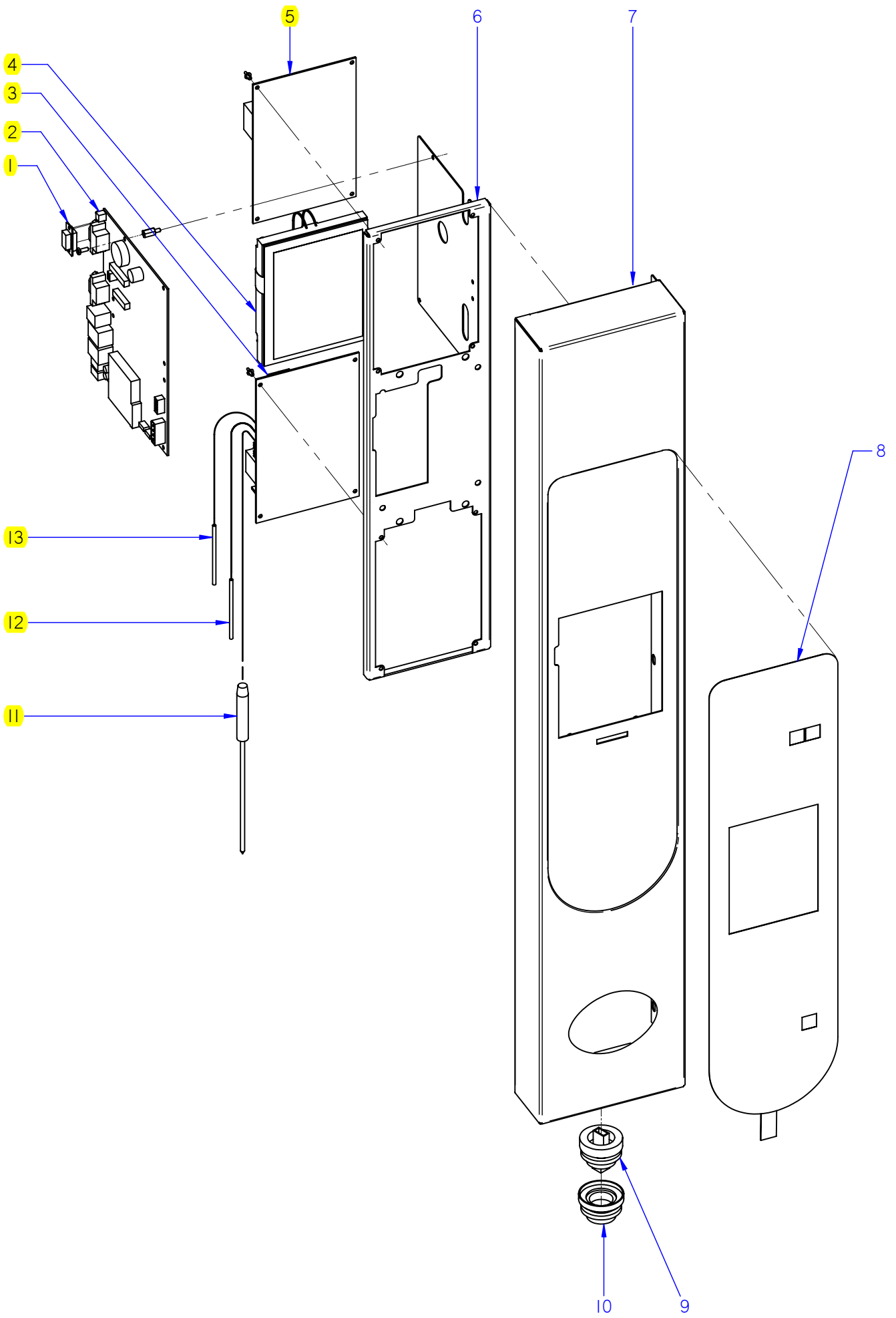

ITEM MARCADO EN COLOR = REPUESTO RECOMENDADO  
 COLOURED ITEM = RECOMMENDED SPARE PART

N plano	Firma	Fecha	Aparato	Lamina	Fagor Industrial S.Coop. <b>FAGOR</b>
C-2414	<i>[Signature]</i>	2009-07	CONJUNTO ELECTRICO PORTAMANDOS HORNOS VPE 6/11; 10/11	10	Oñate



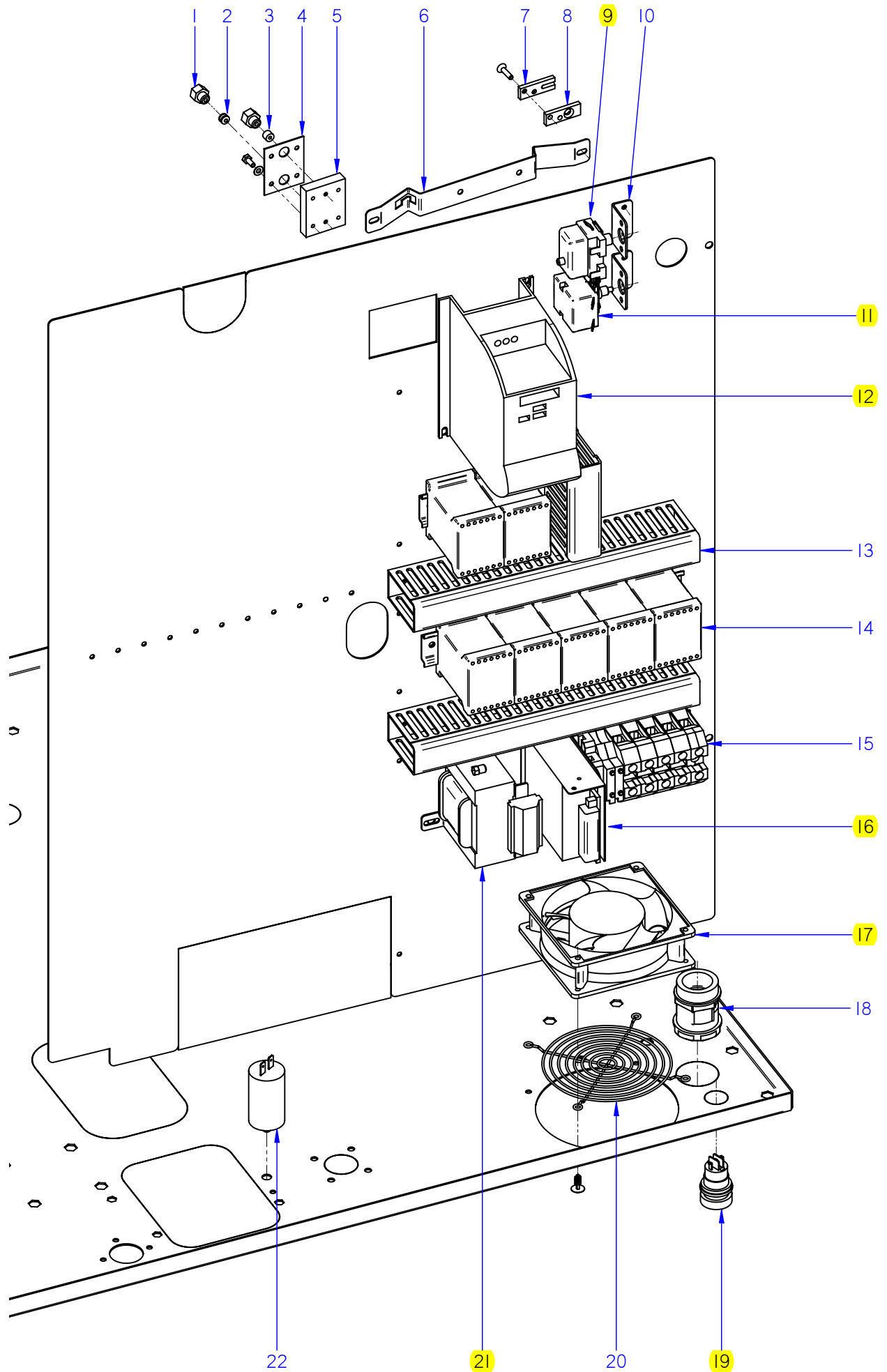

ITEM MARCADO EN COLOR = REPUESTO RECOMENDADO  
 COLOURED ITEM = RECOMMENDED SPARE PART

N plano	Firma	Fecha	Aparato	CUADRO ELECTRICO	Lamina	Fagor Industrial S.Coop. <b>FAGOR</b>
C-2415	<i>[Signature]</i>	2009-07	HORNOS COE; VE; VPE 6/11 - 10/11		11	Oñate

MOD.		HORNOS / OVEN		ZONA		CUADRO ELECTRICO / ELECTRIC PANEL				PLANO		C-2415	
ITEM	CODIGO	DENOMINACION	TEXTO	COE-061	COE-101	VE-061	VE-101	VPE-061	VPE-101			NOTAS	
1	R662629000	RACORD CIERRE SONDA	PROBE CLOSING ADAPTOR	2	2	2	2	2	2				
2	R662652000	BICONO CIERRE SONDA	PROBE CLOSING BICONE	1	1	1	1	1	1				
3	R662662000	JUNTA CIERRE BULBO LIMITADOR	BULB LIMITER CLOSING SEAL	1	1	1	1	1	1				
4	R692811000	JUNTA PASAMUROS DOBLE	FEEDTHROUGH SEAL	1	1	1	1	1	1				
	Q232020000	ARANDELA A4	FLAT WASHER A.4	4	4	4	4	4	4				
	Q012021000	TORNILLO EXAGONAL M4X10	HEXAGONAL BOLT M4X10	4	4	4	4	4	4				
5	R662659000	APOYO RACORD SONDA	PROBE RACORD SUPPORT	1	1	1	1	1	1				
6	R662683000	SOPORTE BULBO	BULB SUPPORT	1	1	1	1	1	1				
	Q412002000	REMACHE AVINOX Ø4x10MM	TUBULAR RIVET 4x7,5	4	4	4	4	4	4				
7	T133037000	TAPA SUJECION SONDA	COVER CORE PROBE	1	1	1	1	1	1				
	Q042022000	TORNILLO AVELLANADO M4X15	BOLT M4X15	2	2	2	2	2	2				
8	T133036000	BASE SUJECION SONDA	FIXING CORE PROBE	-	-	1	1	1	1				
9	Z953035000	TERMOSTATO LIMITADOR AVISO	LIMITER THERMOSTAT WARNIN	-	-	1	1	1	1				
	Z953041000	TUERCA M.10x1 EGO 00.00600.075	NUT M.10x1 EGO 00.00600.075	1	1	2	2	2	2				
10	R343039000	SOPORTE TERMOS VAPOR	THERMOSTAT SUPPORT	1	1	2	2	2	2				
	Q412002000	REMACHE AVINOX Ø4x10MM	TUBULAR RIVET 4x7,5	1	1	2	2	2	2				
11	T303009000	TERMOSTATO LIMITADOR	THERMOSTAT LIMITER	1	1	1	1	1	1				
12	T323037000	VARIADOR FRECUENCIA SIE 0,37	FREQUENCY VARIATOR SIE 0.37	1	1	1	1	1	1				
	Q232020000	ARANDELA A4	FLAT WASHER A.4	6	6	6	6	6	6				
	Q242020000	ARANDELA ABANICO A4 A.304	FAN SHAPED WASHER A.4	6	6	6	6	6	6				
	Q032021000	TORNILLO ALOMADO M4X1C	CURVED SCREW M.4x10	6	6	6	6	6	6				
13	3715520000	CANALETA UNEX 60.30.77 / 0.12	PIPING UNEX 60.30.77 / 0.12	3	3	3	7	3	7				
	Q412002000	REMACHE AVINOX Ø4x10MM	TUBULAR RIVET 4x7,5	18	15	18	20	18	20				
	Q221341000	REMACHE EXAGONAL M.4	HEXAGONAL RIVET M.4	6	6	6	6	6	6				
14	Z203050000	CONTAC. SIRIUS 3R 230V.50-60	SIRIUS 3R 230V.50-60 CONTAC.	3	5	4	7	4	7				
	Z403016000	GUIA CONTACTOR L-100	CONTACTOR GUIDE L-100	1	1	1	1	1	1				
	R693009000	GUIA CONTACTOR L-250	CONTACTOR GUIDE L=250	1	1	1	1	1	1				



MOD.		HORNOS / OVEN		ZONA	VARIOS / MISCELLANEOUS					PLANO	
ITEM	CODIGO	DENOMINACION	TEXTO	COE-061	COE-101	VE-061	VE-101	VPE-061	VPE-101		
	T906501000	MANUAL DE INSTRUCCIONES COE	INSTRUCTIO. BROCHURE COE	1	1	-	-	-	-		
	T916501000	MANUAL DE INSTRUCCIONES VE	INSTRUCTIO. BROCHURE VE	-	-	1	1	-	-		
	T926501000	MANUAL DE INSTRUCCIONES VPE	INSTRUCTIO. BROCHURE VPE	-	-	-	-	1	1		
	T903001000	ESQUEMA TEORICO E 6/11	THEORETICAL DIAGRAM E 6/11	1	-	-	-	-	-		PLANO HC-80555
	T803003000	ESQUEMA TEORICO HEI 10/11	THEORETICAL DIAGRAM HEI 10	-	1	-	-	-	-		PLANO HC-80669
	T913001000	ESQUEMA TEORICO E 6/11	THEORETICAL DIAGRAM E 6/11	-	-	1	-	-	-		PLANO HC-80785
	T813003000	ESQUEMA TEORICO E 10/11	THEORETICAL DIAGRAM E 10/11	-	-	-	1	-	-		PLANO HC-80788
	T923003000	ESQUEMA TEORICO VPE-061	THEORETICAL DIAGRAM VPE-06	-	-	-	-	1	-		PLANO HC-80762
	T823001000	ESQUEMA TEORICO VPE-101	THEORETICAL DIAGRAM VPE-10	-	-	-	-	-	1		PLANO HC-80754
	T903002000	PLANO DE MONTAJE E 6/11	ASSEMBLY PLAN E 6/11	1	-	-	-	-	-		PLANO HC-80556
	T803004000	PLANO DE MONTAJE HEI 10/11	ASSEMBLY PLAN HEI 10/11	-	1	-	-	-	-		PLANO HC-80670
	T913002000	PLANO DE MONTAJE E 6/11	ASSEMBLY PLAN E 6/11	-	-	1	-	-	-		PLANO HC-80786
	T813002000	PLANO DE MONTAJE E 10/11	ASSEMBLY PLAN E 10/11	-	-	-	1	-	-		PLANO HC-80787
	T923002000	PLANO DE MONTAJE VPE-061	ASSEMBLY PLAN VPE-061	-	-	-	-	1	-		PLANO HC-80761
	T823002000	PLANO DE MONTAJE VPE-101	ASSEMBLY PLAN VPE-101	-	-	-	-	-	1		PLANO HC-80755
	T903006000	CABLEADO COMUNICACIÓN BMF	COMMUNICATION WIRING BMF	1	1	1	1	1	1		
	T903011000	CABLEADO LUZ INTERIOR	INTERIOR LIGHT WIRING	1	1	1	1	1	1		
	T903004000	CABLEADO VARIADOR CONCEPT	CONCEPT VARIATOR WIRING	1	1	1	-	1	-		
	T823006000	CABLEADO VARIADOR VISUAL	STEAM WIRING VPE-101	-	-	-	1	-	1		
	T903005000	CABLEADO FUERZA COE-6/11	POWER WIRE COE-6/11	1	-	-	-	-	-		
	T803001000	CABLEADO FUERZA COE-101	POWER WIRE COE-101	-	1	-	-	-	-		
	T923005000	CABLEADO FUERZA VPE-061	POWER WIRE VPE VPE-061	-	-	1	-	1	-		
	T823004000	CABLEADO FUERZA VPE-101	POWER WIRE VPE VPE-101	-	-	-	1	-	1		
	T923004000	CABLEADO VAPOR VPE-061	STEAM WIRING VPE-061	-	-	1	-	1	-		
	T823003000	CABLEADO VAPOR VPE-101	STEAM WIRING VPE-101	-	-	-	1	-	1		
	T803002000	CABLEADO CONVECCION:HEI10/11	CONVECTION WIRING: HEI10/11	-	1	-	-	-	-		
	T913006000	CAB CIRCUIT PORTAMANDOS VIS.	VIS. CONTROL HOLDER CIRCUIT	-	-	1	1	-	-		
	T923006000	CABLEADO RESISTENCIAS VPE-061	RESISTOR WIRING VPE-061	-	-	1	-	1	-		
	T823005000	CABLEADO RESISTENCIAS VPE-101	RESISTOR WIRING VPE-101	-	-	-	1	-	1		
	T903003000	INSTAL. ELEC: CONCEPT E 6/11	ELEC. INSTALL: CONCEPT E 6/11	1	1	-	-	-	-		
	T913005000	INSTAL. ELEC: VISUAL E 6/11	ELEC. INSTALL: VISUAL E 6/11	-	-	1	-	-	-		







# VE 061

3N-50/60Hz 380/415V

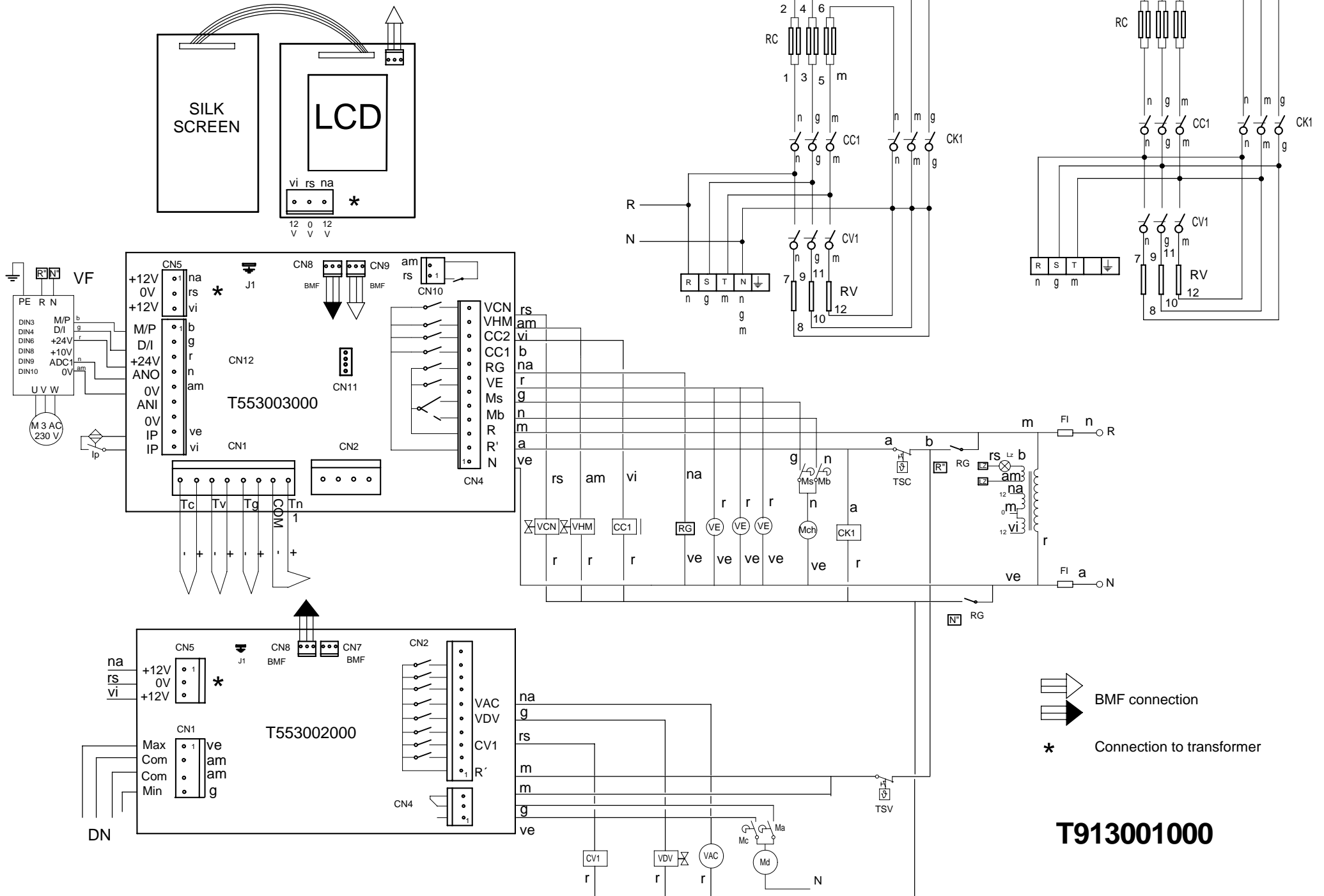

3-50/60Hz 220V

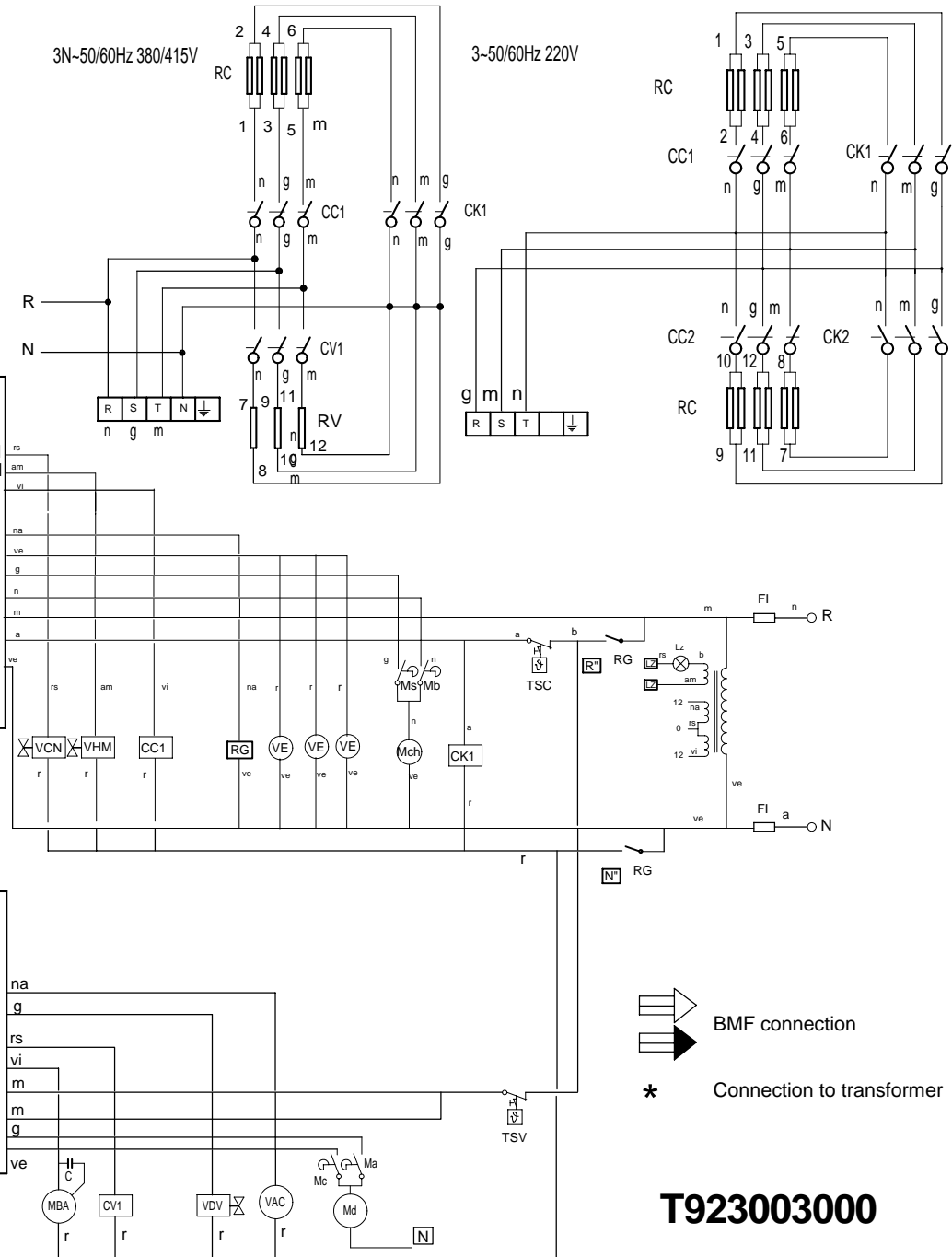
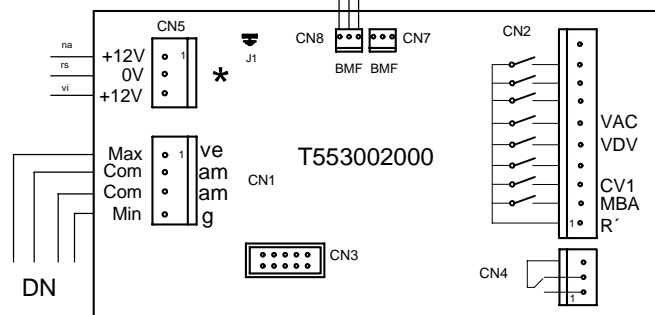
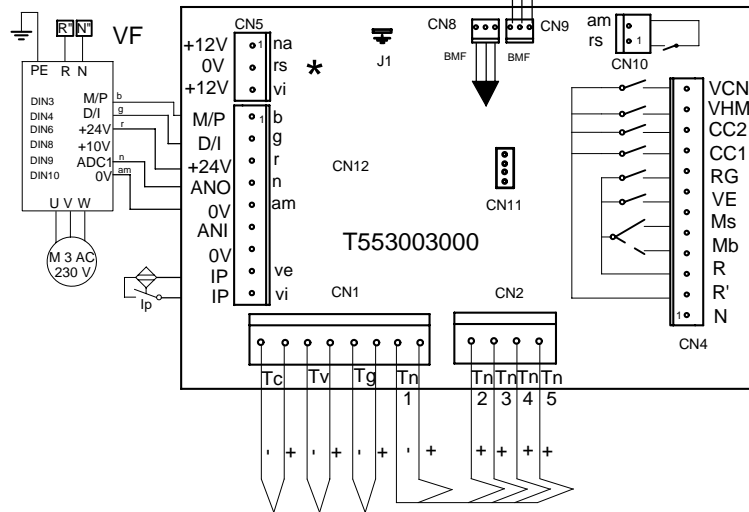
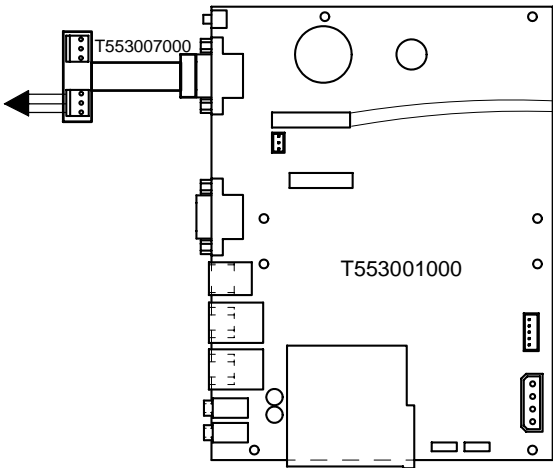

**T913001000**

# VPE 061



-  BMF connection
-  Connection to transformer

**T923003000**

# COE 101

3N-50/60Hz 380/415V

3-50/60Hz 220V

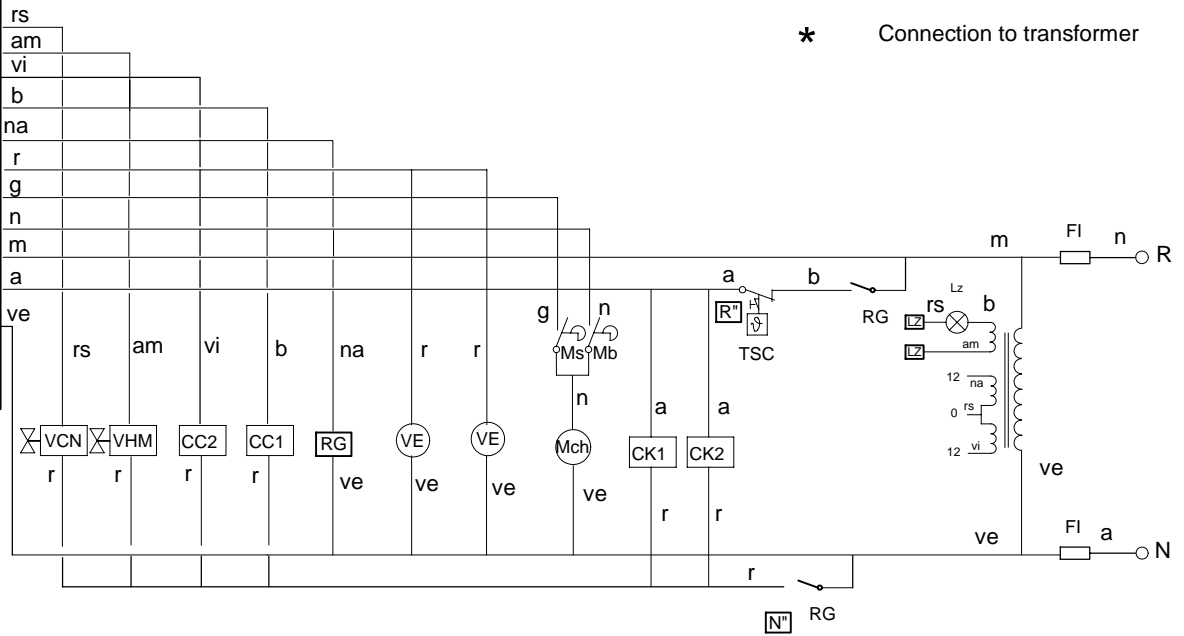
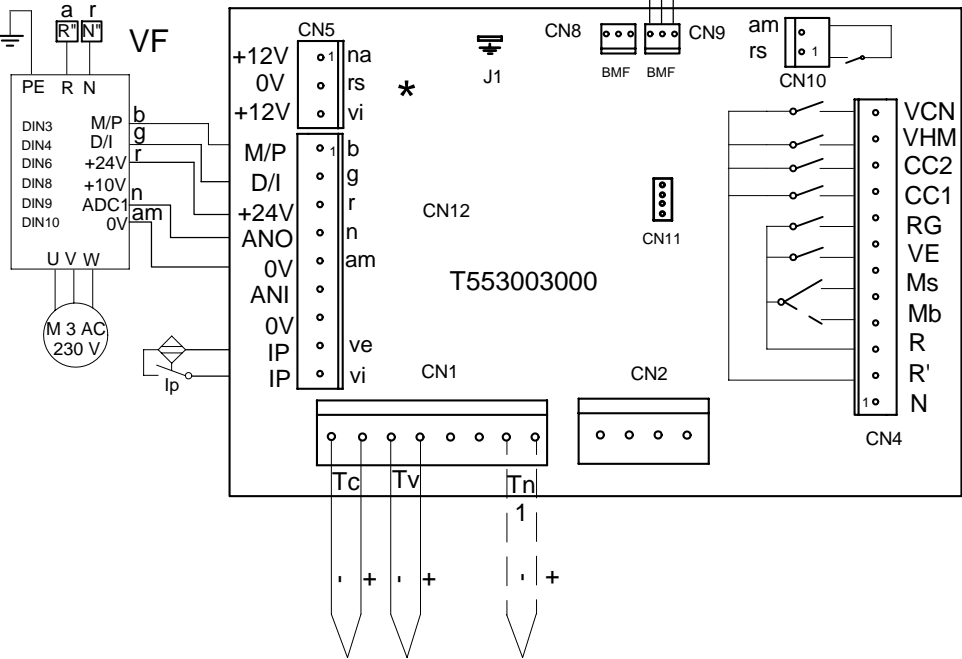
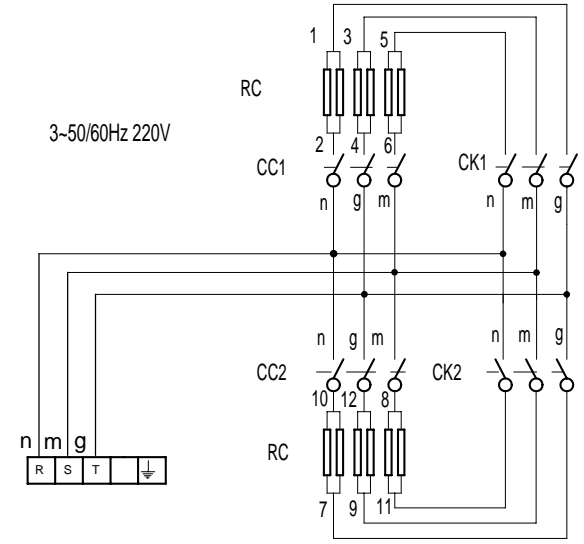
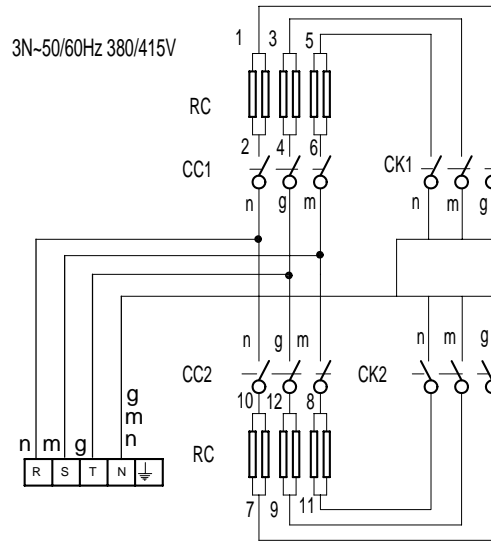
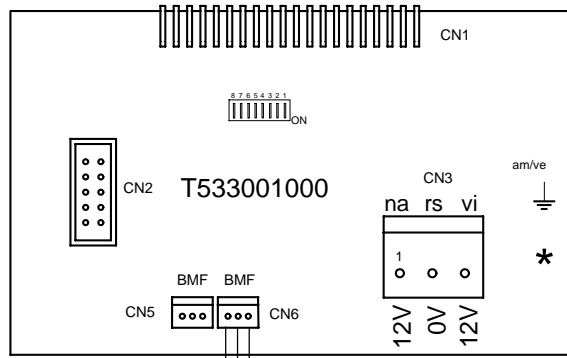

\* Connection to transformer

**T803003000**

# VE 101

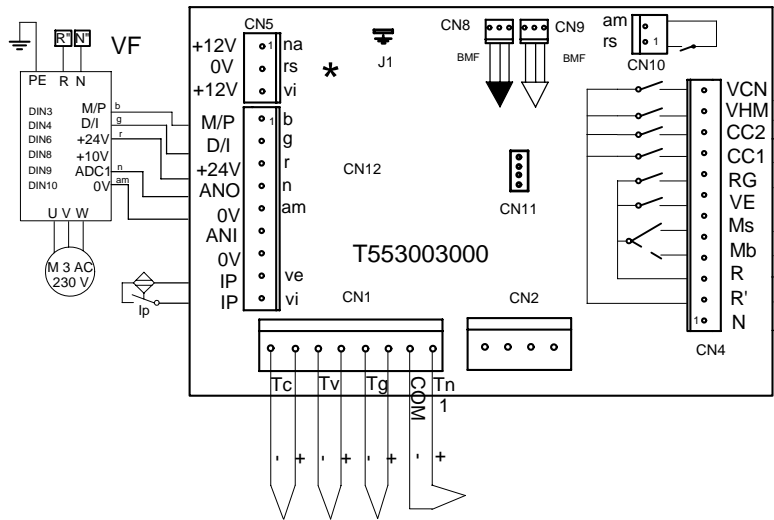
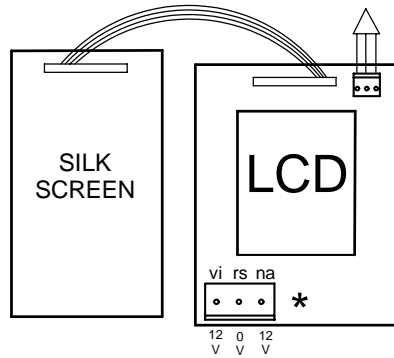

3N-50/60Hz 380/415V

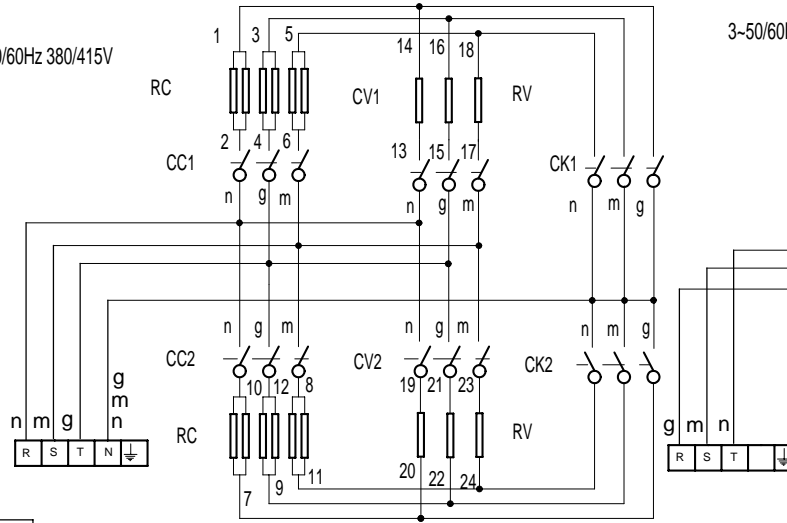

3-50/60Hz 220V

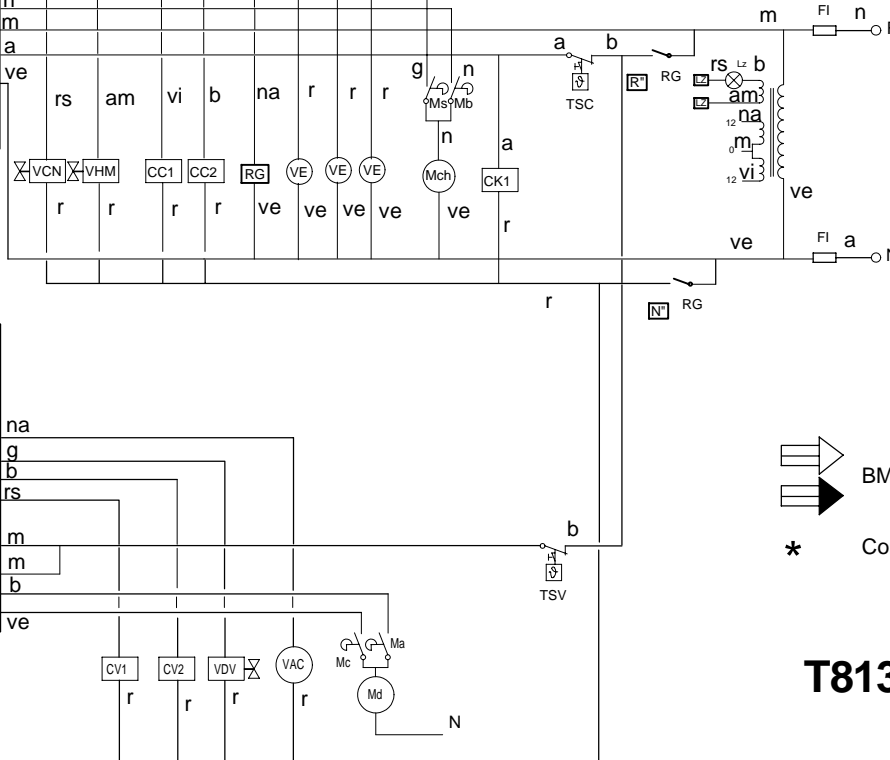
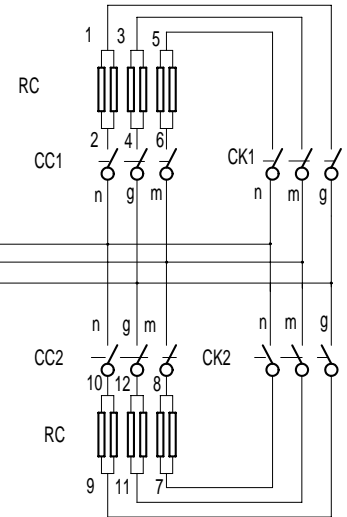

\* Connection to transformer

**T813003000**

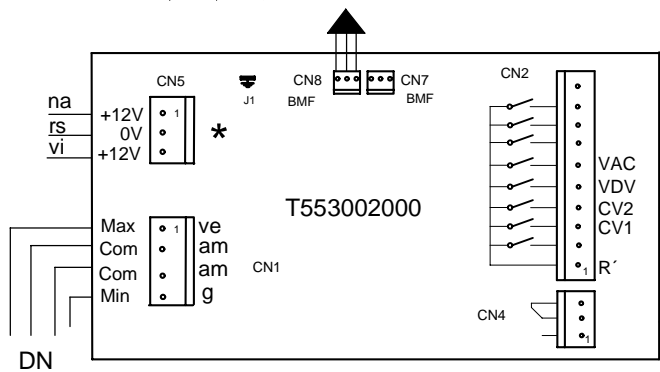

# VPE 101

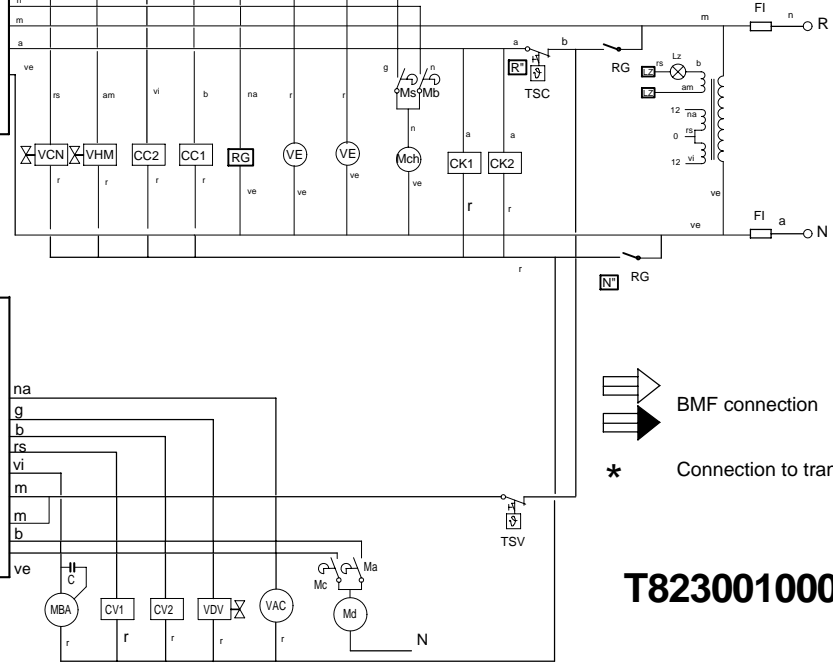
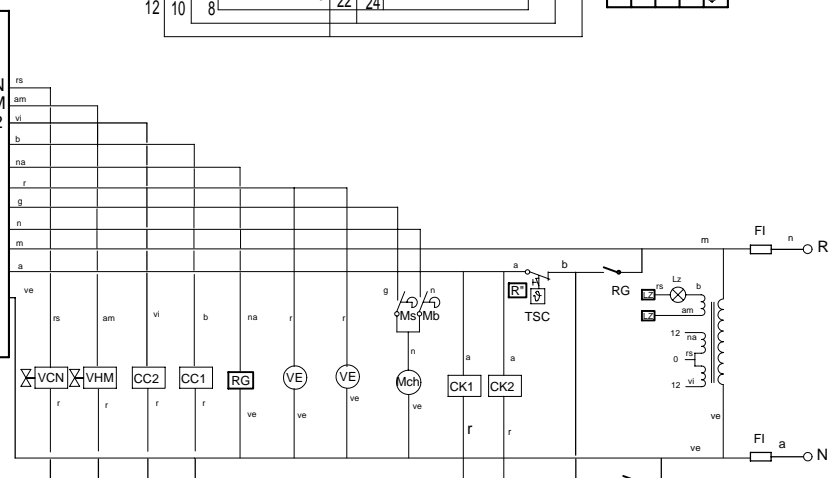
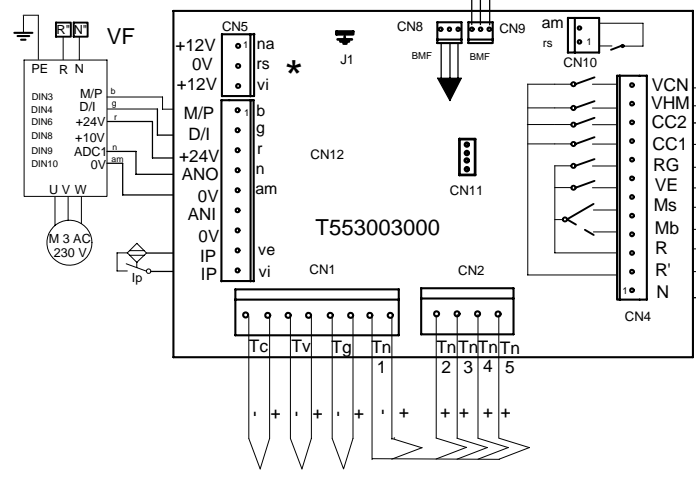
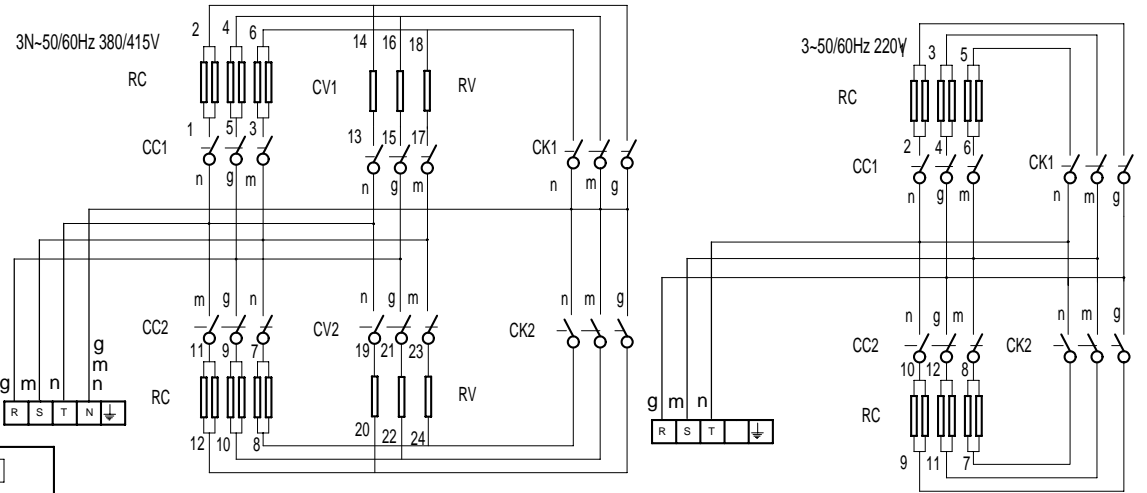
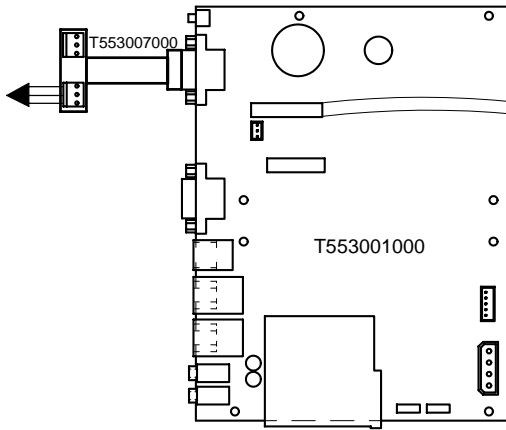

BMF connection  
 Connection to transformer

**T823001000**

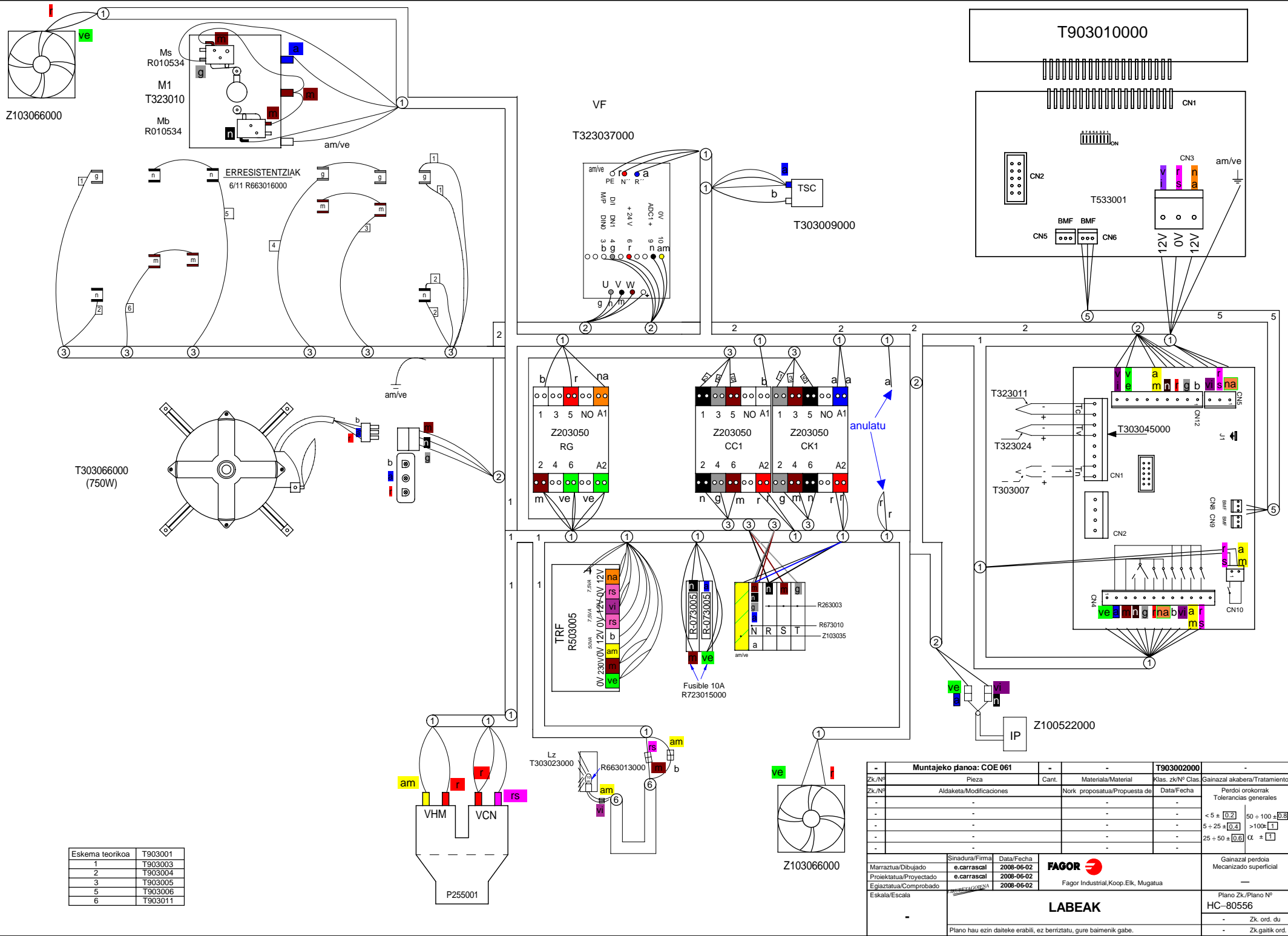

Eskema teorikoa	T903001
1	T903003
2	T903004
3	T903005
5	T903006
6	T903011

Muntajeko plano: COE 061				T903002000	
Zk./Nº	Pieza	Cant.	Materiala/Material	Klas. zk/Nº Clas	Gainazal akabera/Tratamiento
Zk./Nº	Aldaketa/Modificaciones		Nork proposatua/Propuesta de	Data/Fecha	Perdoi orokorrak Tolerancias generales
-	-	-	-	-	< 5 ± 0.2   50 ± 100 ± 0.8
-	-	-	-	-	5 ± 25 ± 0.2   >100 ± 1
-	-	-	-	-	25 ± 50 ± 0.6   α ± 1
Sinadura/Firma				Data/Fecha	<b>FAGOR</b> Fagor Industrial.Koop.Elk. Mugatua Gainazal perdoia Mecanizado superficial
Marratzua/Dibujado				2008-06-02	
Proiektatua/Proyectado				2008-06-02	
Egiaztatua/Comprobado				2008-06-02	
Eskala/Escala					Plano Zk./Plano Nº
					HC-80556
					- Zk. ord. du
					- Zk.gaitik ord.

Plano hau ezin dateke erabili, ez bertizatu, gure baitanik gabe.







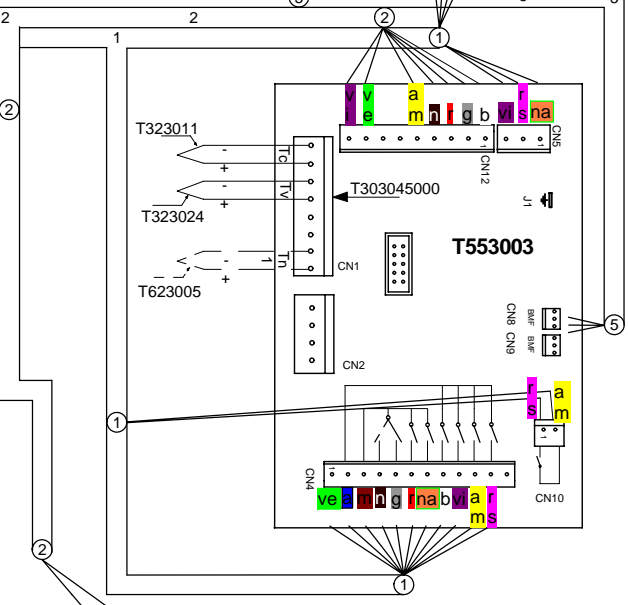
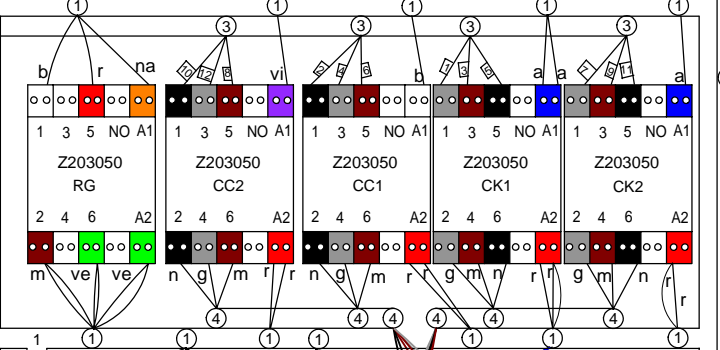
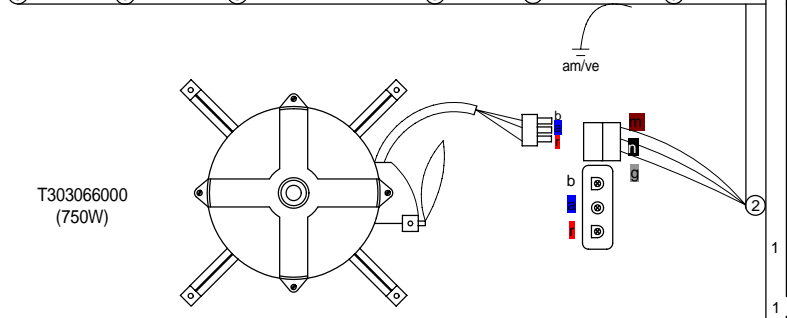
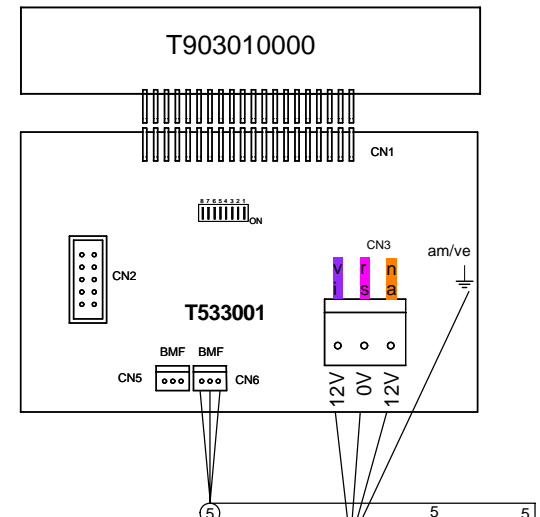
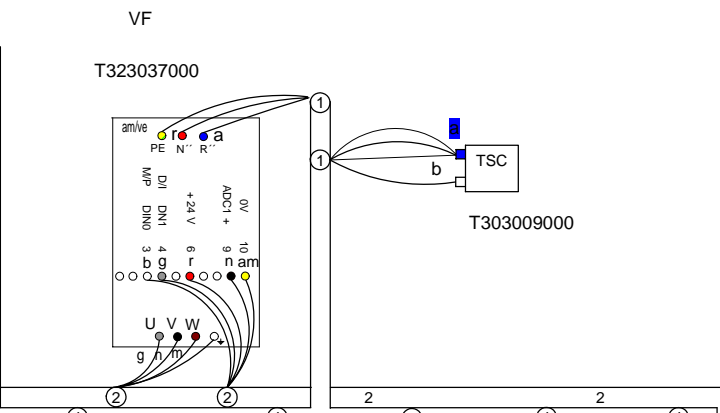
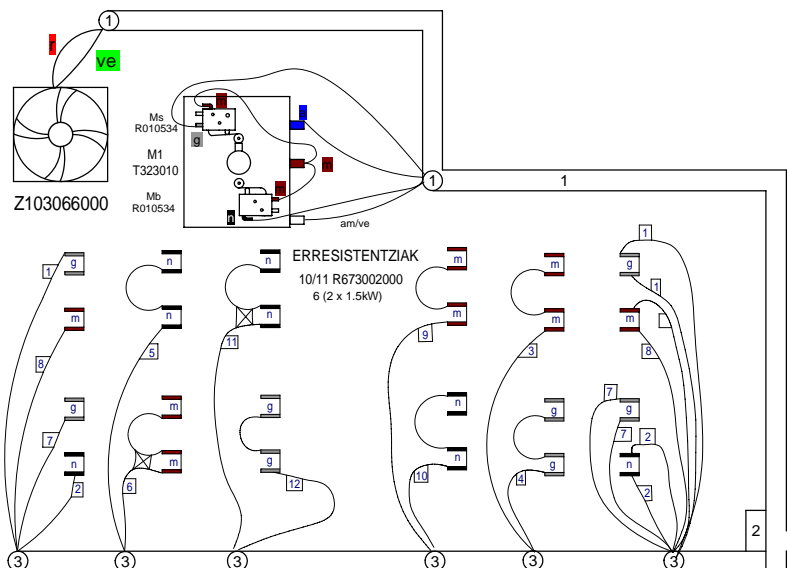

Eskema teorikoa	T803003
1	T903003
2	T903004
3	T803002
4	T803001 x 2
5	T903006
6	T903011

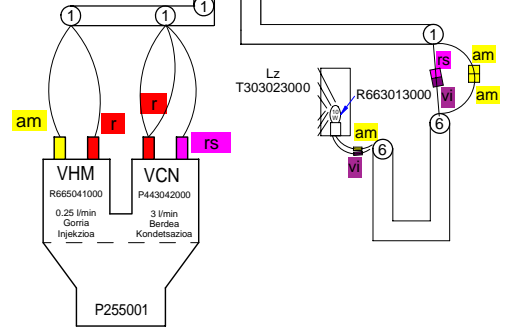
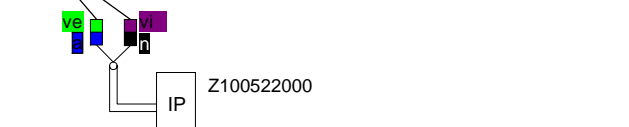
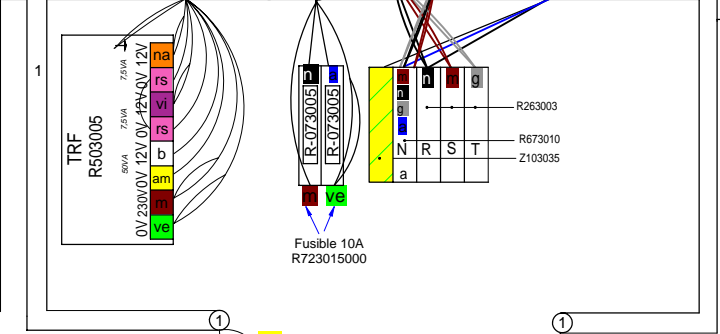

Muntajeko planoak: COE 101			T803004000		
Zk./Nº	Pieza	Cant.	Materiala/Material	Klas. zk/Nº Clas	Gainazal akabera/Tratamiento
Zk./Nº	Aldaketa/Modificaciones	Nork proposatua/Propuesta de	Data/Fecha		Perdoi orokorrak Tolerancias generales
-	-	-	-	-	< 5 ± 0.2   50 ± 100 ± 0.8
-	-	-	-	-	5 ± 25 ± 0.2   >100 ± 1
-	-	-	-	-	25 ± 50 ± 0.8   α ± 1

Sinadura/Firma		Data/Fecha		FAGOR		Gainazal perloia Mecanizado superficial	
Marratzua/Dibujado	e.carrascal	2008-06-02		Fagor Industrial.Koop.Elk. Mugatua		-	
Proiektatua/Proyectado	e.carrascal	2008-06-02				Plano Zk./Plano Nº	
Egiaztatua/Comprobado	FRANZESCA GONZALEZ	2008-06-02				HC-80670	
Eskala/Escala						-	
Plano hau ezin dateke erabili, ez berrizatu, gure baitanik gabe.						-	

**LABEAK**  
 HC-80670  
 - Zk. ord. du  
 - Zk.gaitik ord.

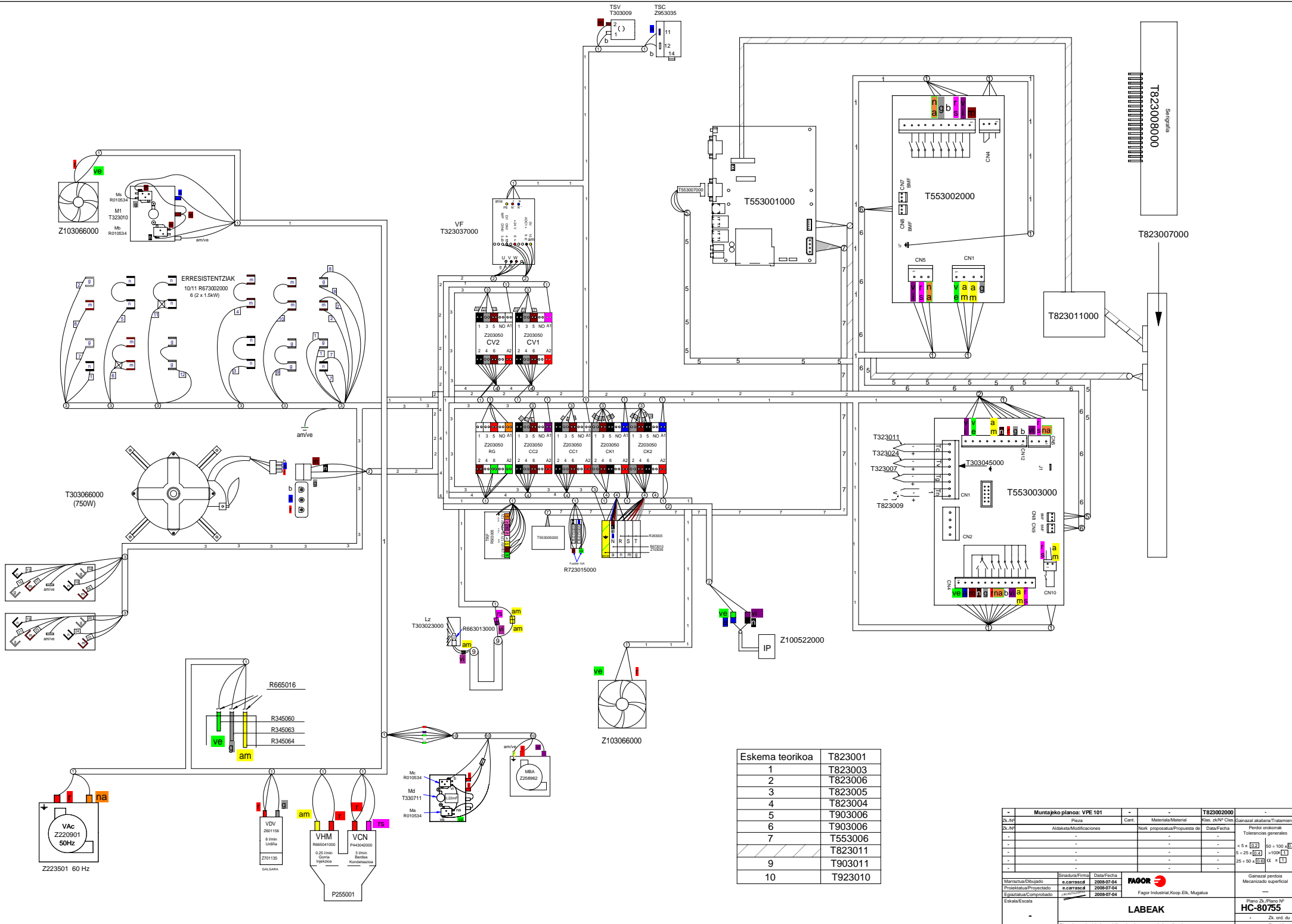

Eskema teorikoa	T823001
1	T823003
2	T823006
3	T823005
4	T823004
5	T903006
6	T903006
7	T553006
	T823011
9	T903011
10	T923010

Muntzako plano: VPE 101				T823002000	
Zk.Nº	Pieza	Cant.	Materia/Material	Klas. zk/Nº Clas.	Gainazal akabera/Tratamiento
Zk.Nº	Aldaketa/Modificaciones		Nork proposatua/Propuesta de	Data/Fecha	Pertxo erorkiak/Tolerancias generales
-	-	-	-	-	-
-	-	-	-	-	± 0.5 ± [0.2]
-	-	-	-	-	± 0.25 ± [0.1]
-	-	-	-	-	± 0.5 ± [0.2] x ± [0.1]
Marrazlea/Dibujado: <b>FAOOR</b> Proiektatzaile/Proyectado: <b>FAOOR</b> Egiaztatua/Comprobado: <b>FAOOR</b>				Data/Fecha: 2008-07-04 Data/Fecha: 2008-07-04 Data/Fecha: 2008-07-04 <b>FAOOR</b> Fagor Industrial, Koop. Elk., Mugatuas	
Eskala/Escala:				Ganazal pentada Mecanizado superficial <b>HC-80755</b>	
Plano hau ezin daterik erabili, ez berrintzatu, gure baimenik gabe.				Plano de taller Nº <b>HC-80755</b> - Zk. ord. du - - Zk. gaitik ord. -	