

**Hornos Mixtos
Fours Mixtes
Combi Ovens
HeiBluftdämpfer
Forno Misti**

Modelos:

HEI-20/11

HEM-20/11

HEP-20/11

Diciembre 2007 December

FAGOR 

Fagor Industrial

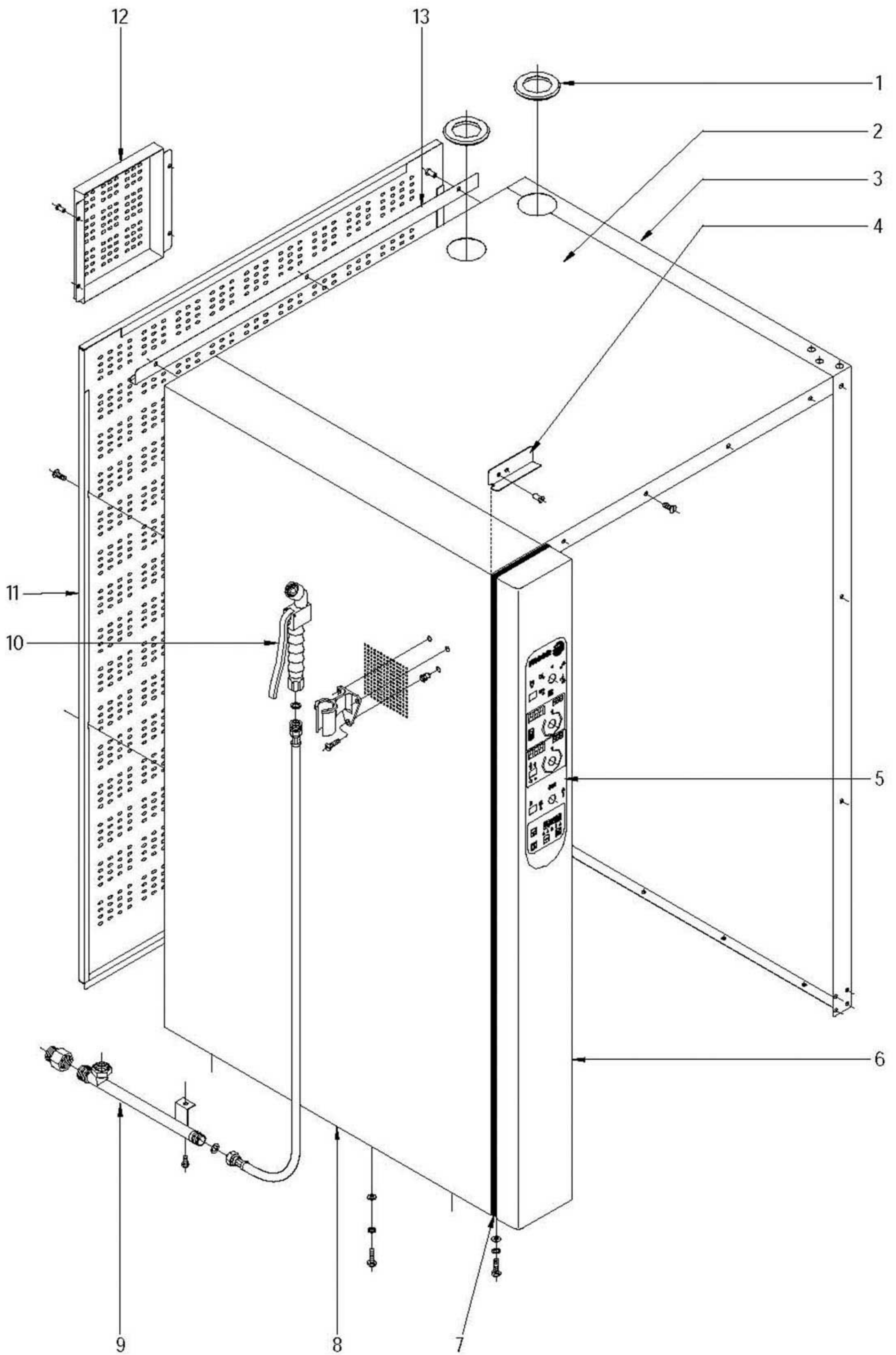

MOD.	HORNOS	ZONA	MUEBLE	PLANO	C-1947
------	--------	------	--------	-------	--------

ITEM	CODIGO	DENOMINACION	TEXTO	HEI 20/11	HEM 20/11	HEP 20/11						NOTAS
1	R662813000	PASAMUROS CHIMENEA 101003361	FEEDTHROUGH FLUE PIPE 1010	2	2	2						
2	R092880000	PANEL SUPERIOR 20/11	UPPER PANEL	1	1	1						
	Q221343000	REMACHE EXAGONAL M6	HEXAGONAL RIVET M.6	4	4	4						
	Q232040000	ARANDELA A6	FLAT WASHER A.6	4	4	4						
	Q262040000	ARANDELA GROW. A6 A.304	GROWER WASHER A.6	4	4	4						
	Q012042000	TORNILLO EXAGONAL M6x15	HEXAGONAL BOLT M6x15	4	4	4						
3	R092879000	PANEL LATERAL DERECHO 20/11	RIGHT SIDE PANEL	1	1	1						
	Q012042000	TORNILLO EXAGONAL M6x15	HEXAGONAL BOLT M6x15	4	4	4						
	Q262040000	ARAND.GROW. A6 A.304	GROWER WASHER A.6	4	4	4						
	Q232040000	ARANDELA A6	FLAT WASHER A.6	4	4	4						
4	R662811000	FIJACION PORTAMANDOS	CONTROL PANEL FIXATION	1	1	1						
	Q412002000	REMACHE AVINOX Ø4x10MM	TUBULAR RIVET 4x7,5	2	2	2						
5	R703042000	SERIGRAFIA HEI-10/11	SERIGRAPHY HEI-10 / 11	1	-	-						
5	R673067000	SERIGRAFIA HEM-10/11 20/11	SERIGRAPHY HEM-10/11 20/11	-	1	-						
5	R673068000	SERIGRAFIA HEP-10/11 20/11	SERIGRAPHY HEP-10/11 20/11	-	-	1						
6	T102817000	PANEL PORTAMANDOS HGC-20/11	CONTROL PANEL	1	-	-						
6	R092867000	PORTAMANDOS COMPLETO 20/11	COMPLETE CONTROL HOLDER 2	-	1	1						
7	3715400000	JUNTA PANEL PORTAMANDOS	SEAL CONTROL HOLDER PANEL	3	3	3						
8	R092870000	PANEL LATERAL IZDO 20/11	LEFT SIDE PANEL 20/11	1	1	1						
	Q012042000	TORNILLO EXAGONAL M6x15	HEXAGONAL BOLT M6x15	4	4	4						
	Q262040000	ARAND.GROW. A6 A.304	GROWER WASHER A.6	4	4	4						
	Q232040000	ARANDELA A6	FLAT WASHER A.6	4	4	4						
9	R675002000	SUPLEMENTO DUCHA	SUPPLEMENT FOR SHOWER SE	-	1	1						
	Q306039000	ARANDELA JUNTA 23,8X16,2X1,5	JOINT WASHER 23,8x16,2x1,5	-	1	1						
	Q012042000	TORNILLO EXAGONAL M6x15	HEXAGONAL BOLT M6x15	-	1	1						
10	R095009000	DUCHA COMPLETA	COMPLETE SHOWER	-	1	1						
	Q042022000	TORNILLO AVELLANADO M4x15	COUNTERSUNK SCREW M.4x15	-	3	3						
11	R092869000	PANEL POSTER. EXT. HEM/P 20/11	EXT. REAR PANEL HEM/P 20/11	1	1	1						
	Q152017000	TORNILLO AMARRE M6X13 A304	SCREW M.6x13	4	4	4						
	Q221343000	REMACHE EXAGONAL M6	HEXAGONAL RIVET M.6	4	4	4						

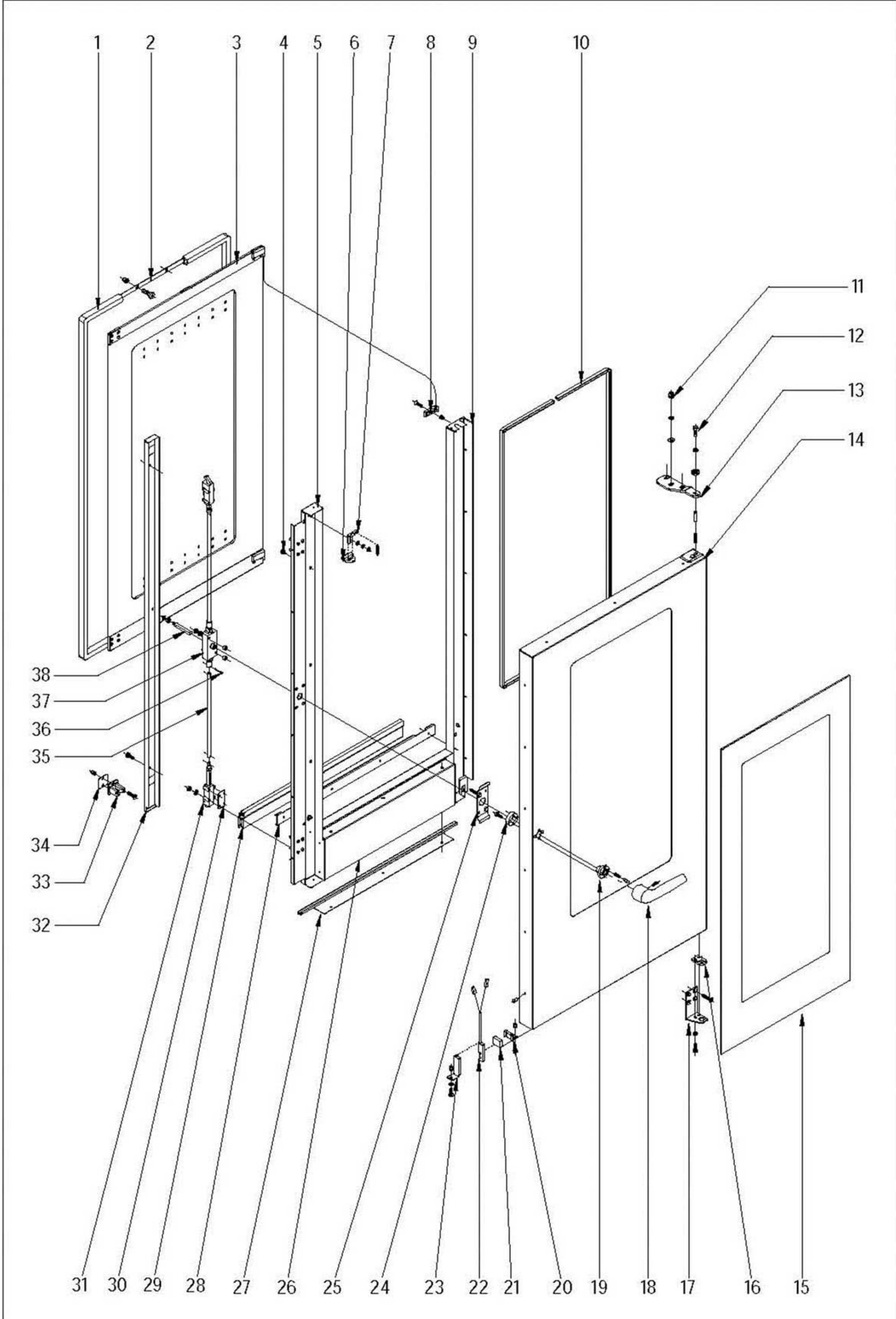

N plano	Firma	Fecha	Aparato	PUERTA	Lamina	Fagor Industrial S.Coop. FAGOR
C-1948	<i>[Signature]</i>	2007-12	HORNOS HEI; HEM; HEP-20/11		2	Orate

MOD.		HORNOS		ZONA		PUERTA			PLANO		C-1948	
ITEM	CODIGO	DENOMINACION	TEXTO	HEI 20/11	HEM 20/11	HEP 20/11						NOTAS
	1100003126	KIT PUERTA 20/11 COMPL.	DOOR 20/11 KIT	1	1	1						
1	R090510000	JUNTA DE PUERTA 20-11	DOOR JOINT	1	1	1						
2	R090512000	FIJACION JUNTA COMP 20/11	COMPLETE FIXATION JOINT	1	1	1						
	Q032021000	TORN.ALOM.M4X10	CURVED SCREW M.4x10	40	40	40						
	Q222041000	REMACHE EXAGONAL M4 (INOX)	HEXAGONAL RIVET M.4	40	40	40						
3	1100003125	KIT CRISTAL INTER. 20/11 COMPL.	20/11 INNER GLASS KIT	1	1	1						
4	T300513000	TOPE CRISTAL INTERIOR 10/21	INNER GLASS DOOR STOP	8	8	8						
5	R090569000	CONTRAP MANILLA COMPL 20/11	COMPLETE HANDLE DOOR 20/11	1	1	1						
6	T300514000	PESTILLO 10/21	INNER GLASS FASTENING LATC	2	2	2						
7	R090558000	BASE DE PESTILLO	LATCH BASE	2	2	2						
	Q302022000	ARANDELA 16X6X1.2 A.304	FLAT WASHER 16x6x1,2	2	2	2						
	Q162040000	TUERCA EXAGONAL M6	HEXAGONAL NUT M.6	2	2	2						
	Q242040000	ARANDELA ABANICO A6 A.304	FAN SHAPED WASHER A.6	2	2	2						
	R660605000	MUELLE TENSOR	LATCH TENSOR SPRING	2	2	2						
8	R670615000	BASE DE BISAGRA	HINGE BASE	2	2	2						
	Q222011000	REMACHE EXAGONAL M.5	HEXAGONAL RIVET M.5	2	2	2						
	Q042032000	TORNILLO AVELLANADO M5X15	COUNTERSUNK SCREW M.5x15	2	2	2						
9	R090567000	CONTRAPUERTA BISA COMP 20/11	COMP. HINGE DOOR REVERSE 2	1	1	1						
10	3715200000	JUNTA CRISTAL	WINDOW SEAL	1	1	1						
11	Q212051000	TUERCA SOMBRERETE M8	CAP NUT M.8	3	3	3						
	Q242050000	ARANDELA ABANICO A8 A.304	FAN SHAPED WASHER A.8	3	3	3						
	Q302025000	ARANDELA 8,4x20x1,5 A.304	FLAT WASHER 8,4x20x1,5	3	3	3						
12	Q012042000	TORNILLO EXAGONAL M6x15	HEXAGONAL BOLT M6x15	1	1	1						
	Q242040000	ARANDELA ABANICO A6 A.304	FAN SHAPED WASHER A.6	1	1	1						
	R662807000	ARANDELA AMARRE	DOOR ANCHORING WASHER	1	1	1						
13	T300520000	BISAGRA SUPERIOR	UPPER HINGE	1	1	1						
	R660534000	EJE SUPERIOR	UPPER SHAFT	1	1	1						
	Z850519000	RESORTE 06329	SPRING	1	1	1						
14	R090565000	PUERTA COMPLETA 20-11	COMPLETE DOOR	1	1	1						
	Q412002000	REMACHE AVINOX Ø4x10MM	TUBULAR RIVET 4x7,5	14	14	14						
15	R090562000	CRISTAL EXTERIOR 20/11	EXTERNAL GLASS	1	1	1						

MOD.		HORNOS		ZONA	PUERTA			PLANO	C-1948
ITEM	CODIGO	DENOMINACION	TEXTO	HEI 20/11	HEM 20/11	HEP 20/11			NOTAS
16	R660549000	GUIA EJE INFERIOR FUNDIDO	LOWER SHAFT GUIDE	1	1	1			
	Q062040000	TORNILLO AVELLANADO M6X16	COUNTERSUNK SCREW M.6x16	4	4	4			
17	R090561000	BISAGRA INFERIOR PLEGADA	LOWER FOLDER HINGE	1	1	1			
	Q242040000	ARANDELA ABANICO A6 A.304	FAN SHAPED WASHER A.6	2	2	2			
	Q012041000	TORNILLO EXAGONAL M6x10 A304	HEXAGONAL SCREW M.6x10	2	2	2			
18	T130502000	MANILLA COMPLETA	HANDLE	1	1	1			
	Q132042000	VARILLA ROSCADA M6X15	THREADED ROD M.6x15	1	1	1			
	T130510000	TAPON Ø 16 BAGAL Ext.	COVER Ø 16 BAGAL Ext.	1	1	1			
19	T130515000	GUIA MANILLA	HANDLE GUIDE	1	1	1			
	T490518000	PITON ENGANCHE PUERTA	DOOR FASTENER SPIKE	2	2	2			
	T130506000	RESORTE 34548	SPRING	2	2	2			
20	T300525000	SOPORTE IMAN	MAGNET HOLDER	1	1	1			
	Q222011000	REMACHE EXAGONAL M.5	HEXAGONAL RIVET M.5	1	1	1			
	Q032031000	TORNILLO ALOMADO M5X10	CURVED SCREW M.5x10	1	1	1			
21	T300526000	IMAN	MAGNET	1	1	1			
22	Z100522000	INTERRUPTOR MAGNETICO	MAGNETIC SWITCH (DOOR)	1	1	1			
23	T302819000	SOPORTE MICRO PUERTA	DOOR MAGNETIC SWITCH HOLD	1	1	1			
	Q222011000	REMACHE EXAGONAL M.5	HEXAGONAL RIVET M.5	1	1	1			
	Q242030000	ARANDELA ABANICO A5 A.304	FAN SHAPED WASHER A.5	1	1	1			
	Q152004000	TORNIL. APLASTADO M5X13 A 304	FLAT SCREW M.5x13	1	1	1			
24	T130514000	SOPORTE RESORTE	SPRING HOLDER	1	1	1			
	Q032032000	TORNILLO ALOMADO M5x15	CURVED SCREW M.5x15	2	2	2			
25	T130511000	SUPLEMENTO SUJ. CERRADURA	LOCK FIXING SUPPLEMENT	1	1	1			
26	R090570000	CHAPA AMARRE CONTRAP 20/11	DOOR REVERSE PLATE FASTEN	1	1	1			
27	R090571000	SUPERIOR CIERRE PUERTA 20/11	DOOR UPPER LOCK 20/11	1	1	1			
28	R090553000	CHAPA JUNTA CONTRAPUERTA	DOOR REVERSE SEAL PLATE	1	1	1			
29	R090551000	JUNTA CIERRE INFERIOR 20/11	SEAL LOWER LOCK 20/11	1	1	1			
30	T080503000	SUPLEMENTO ELEMENTO CIERRE	CLOSING ELEMENT SUPPLEMEN	6	6	6			
31	T080504000	ELEMENTO CIERRE	CLOSING COMPONENT	2	2	2			
	Q262040000	ARAND.GROW. A6 A.304	GROWER WASHER A.6	8	8	8			
	Q162040000	TUERCA EXAGONAL M6	HEXAGONAL NUT M.6	8	8	8			

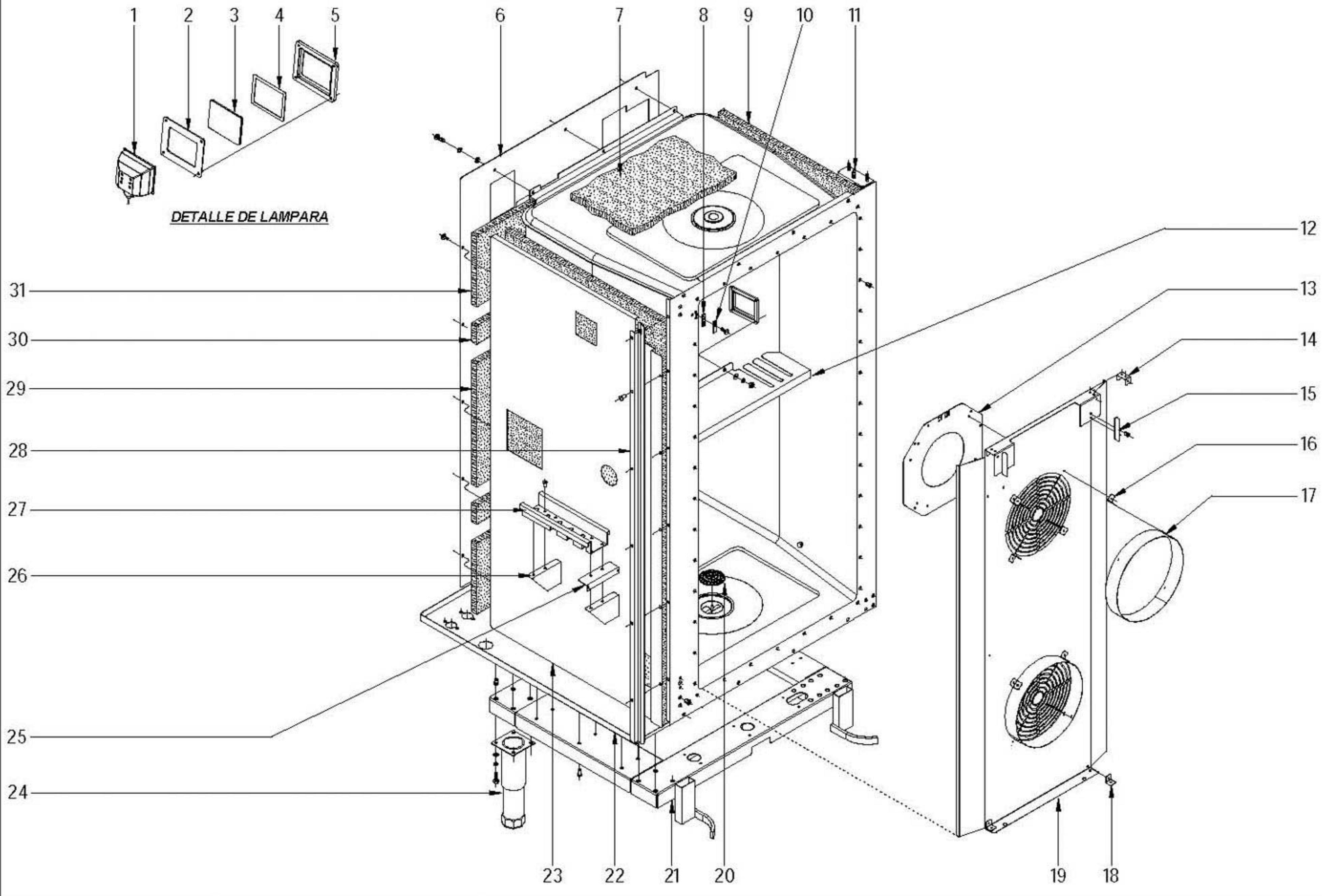

N plano	Firma	Fecha	Aparato	Módulo	Lamina	Fagor Industrial S.Coop. FAGOR
C-1949	<i>[Signature]</i>	2007-12	HORNOS HEI; HEM; HEP-20/11	MUEBLE INTERIOR	3	Orate

MOD.		HORNOS		ZONA		MUEBLE INTERIOR			PLANO		C-1949
ITEM	CODIGO	DENOMINACION	TEXTO	HEI 20/11	HEM 20/11	HEP 20/11					NOTAS
1	T303023000	PORTALAMPARAS	LAMP HOLDER	2	2	2					
2	T303026000	JUNTA EXTERIOR LAMPARA	LAMP OUTER JOINT	2	2	2					
3	T303025000	CRISTAL LAMPARA	LAMP GLASS	2	2	2					
4	T303027000	JUNTA INTERIOR LAMPARA	LAMP INNER JOINT	2	2	2					
5	T303047000	MARCO LAMPARA	LAMP ANCHORING PLATEN	2	2	2					
	R663013000	LAMPARA 10W-12V	LIGHT 10W 12V	2	2	2					
	Q222041000	REMACHE EXAGONAL M.4 INOX	HEXAGONAL RIVET M.4	8	8	8					
	Q032021000	TORNILLO ALOMADO M4X10	CURVED SCREW M.4x10	8	8	8					
6	R092652000	SOPORTE AISLANTE POST. 20/11	REAR INSULATION SUPPORT	1	1	1					
	Q221343000	REMACHE EXAGONAL M.6	HEXAGONAL RIVET M.6	12	12	12					
	Q232040000	ARANDELA A6	FLAT WASHER A.6	24	24	24					
	Q262040000	ARAND.GROW. A6 A.304	GROWER WASHER A.6	24	24	24					
	Q012042000	TORNILLO EXAGONAL M6x15	HEXAGONAL BOLT M6x15	24	24	24					
7	R662614000	AISLANTE 650X650X20	BASE&ROOF INSULATION 650x650	6	6	6					
8	T133036000	BASE SUJECION SONDA	FIXING CORE PROBE	-	1	1					
9	R092622000	AISLANTE 1370X650X20	INSULATION 1370X650X20	5	5	5					
10	T133037000	TAPA SUJECION SONDA	COVER CORE PROBE	-	1	1					
11	R092644000	CUERPO INTERIOR HEI-20/11	INNER BODY HEI-20/11	1	-	-					
11	R092640000	CUERPO INTERIOR HEM-20/11	INNER BODY HEM-20/11	-	1	1					
	R662636000	REFUERZO BASE 2011	BASE REINFORCEMENT 2011	1	1	1					
	Q162040000	TUERCA EXAGONAL M6	HEXAGONAL NUT M.6	8	8	8					
12	R092683000	SEPARADOR CENTRAL 20-11E	CENTRAL REPARATOR 20-11E	1	1	1					
	Q232040000	ARANDELA A6	FLAT WASHER A.6	2	2	2					
	Q262040000	ARAND.GROW. A6 A.304	GROWER WASHER A.6	2	2	2					
	Q162040000	TUERCA EXAGONAL M6	HEXAGONAL NUT M.6	2	2	2					
13	T322606000	REDUCC. CUBREVENT. 60HzD160	FANCOVER REDUC. 60HzD160	2	2	2					SOLO HORNOS A 60 HZ
14	R092680000	FIJACIÓN SUPLEMENTO DOBLE	DOUBLE SUPPLEMENT ATTACHN	2	2	2					
	Q412002000	REMACHE AVINOX Ø4x10MM	TUBULAR RIVET 4x7,5	8	8	8					
15	R092677000	ESCUADRA SUJECCION	FASTENING BRACKET	2	2	2					
	Q412002000	REMACHE AVINOX Ø4x10MM	TUBULAR RIVET 4x7,5	4	4	4					

MOD.	HORNOS		ZONA	MUEBLE INTERIOR			PLANO		C-1949
ITEM	CODIGO	DENOMINACION	TEXTO	HEI 20/11	HEM 20/11	HEP 20/11			NOTAS
16	T302643000	FIJACION SUPLEMENTO	FAN COVER SUPPLEMENT BINDI	8	8	8			
	Q412002000	REMACHE AVINOX Ø4x10MM	TUBULAR RIVET 4x7,5	16	16	16			
17	T132644000	2011G SUPL. CUBREVENTILADOR	2011G SUPPL. FAN COVER	2	2	2			
18	T302643000	FIJACION SUPLEMENTO	FAN COVER SUPPLEMENT BINDI	2	2	2			
	Q412002000	REMACHE AVINOX Ø4x10MM	TUBULAR RIVET 4x7,5	4	4	4			
19	R092643000	CUBREVENTILADOR 20/11E	FAN COVER 20/11E	1	1	1			
	Q412002000	REMACHE AVINOX Ø4x10MM	TUBULAR RIVET 4x7,5	23	23	23			
20	R092682000	FILTRO DESAGÜE	DRAINAGE FILTER	1	1	1			
	Q232030000	ARANDELA A5	FLAT WASHER A.5	1	1	1			
	Q162030000	TUERCA EXAGONAL M5	HEXAGONAL NUT M.5	1	1	1			
21	T132831000	REFUERZO APOYOS COMP.20/11	COMP.SUPPORT REINFORCEMB	1	1	1			
	Q412002000	REMACHE AVINOX Ø4x10MM	TUBULAR RIVET 4x7,5	24	24	24			
22	R092878000	BASE EXTERIOR DE HORNO 20/11	OVEN OUTER BASE 20/11	1	1	1			
23	T132610000	SOPORTE LATER. AISLANTE 20/11	SIDE SUPPORT INSULATION 20/	1	1	1			
24	R092830000	PATA REF. AA179EOAQ47CCN	REGULABLE LEG	4	4	4			
	Q221343000	REMACHE EXAGONAL M6	HEXAGONAL RIVET M.6	16	16	16			
	Q242040000	ARANDELA ABANICO A6 A.304	FAN SHAPED WASHER A.6	16	16	16			
	Q012042000	TORNILLO EXAGONAL M6x15	HEXAGONAL BOLT M6x15	16	16	16			
25	R092693000	FIJACION PANEL LATERAL	SIDE PANEL ATTACHMENT	1	1	1			
	Q412002000	REMACHE AVINOX Ø4x10MM	TUBULAR RIVET 4x7,5	3	3	3			
26	R092672000	REFUERZO PEDESTAL	PEDESTAL REINFORCEMENT	2	2	2			
	Q412002000	REMACHE AVINOX Ø4x10MM	TUBULAR RIVET 4x7,5	8	8	8			
27	R342802000	GUIA CUADRO ELECTRICO "	SWITCHBOARD GUIDE"	1	1	1			
28	R092670000	PROTECTOR PORTAMANDOS	CONTROL HOLDER PROTECTOR	1	1	1			
	Q412002000	REMACHE AVINOX Ø4x10MM	TUBULAR RIVET 4x7,5	6	6	6			
29	R092624000	AISLANTE 670X400X20	CENTRAL INSULATOR 670x400x2	1	1	1			
30	R662616000	AISLANTE 560X60X20	REAR INSULATION 560x60x20	6	6	6			
31	R672631000	AISLANTE 670X200X20	INSULATION 670x230x20	2	2	2			

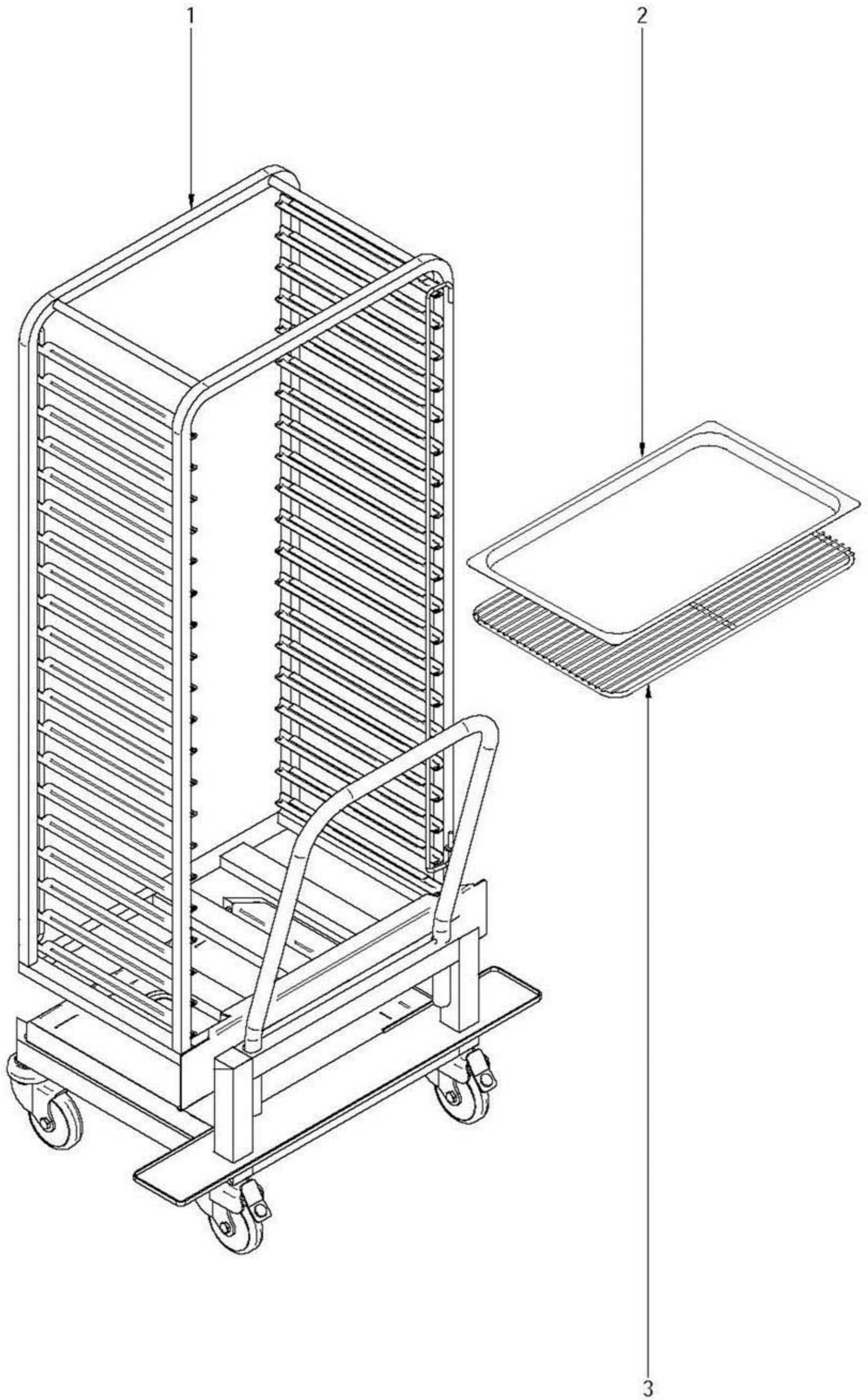

N plano

C-1950

Firma

rene benito

Fecha

2007-12

Aparato

HORNOS HEI; HEM; HEP-20/11

CARRO

Lamina

4

Fagor Industrial S.Coop.

Orate

FAGOR



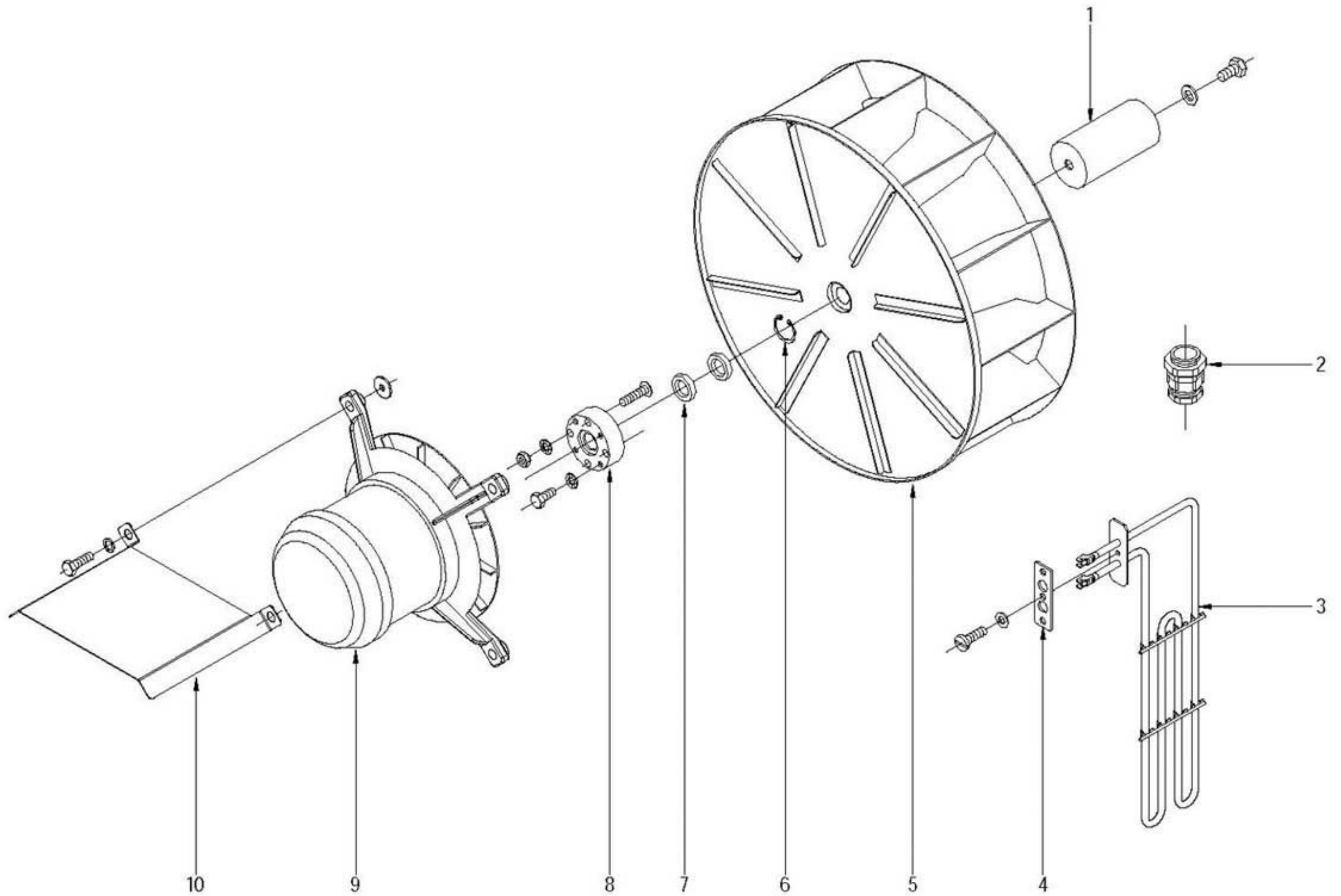

N plano	Firma	Fecha	Aparato	TUREINA	Lamina	Fagor Industrial S.Coop. FAGOR
C-1951	<i>[Signature]</i>	2007-12	HORNO HEI 20/11		5	Dfete

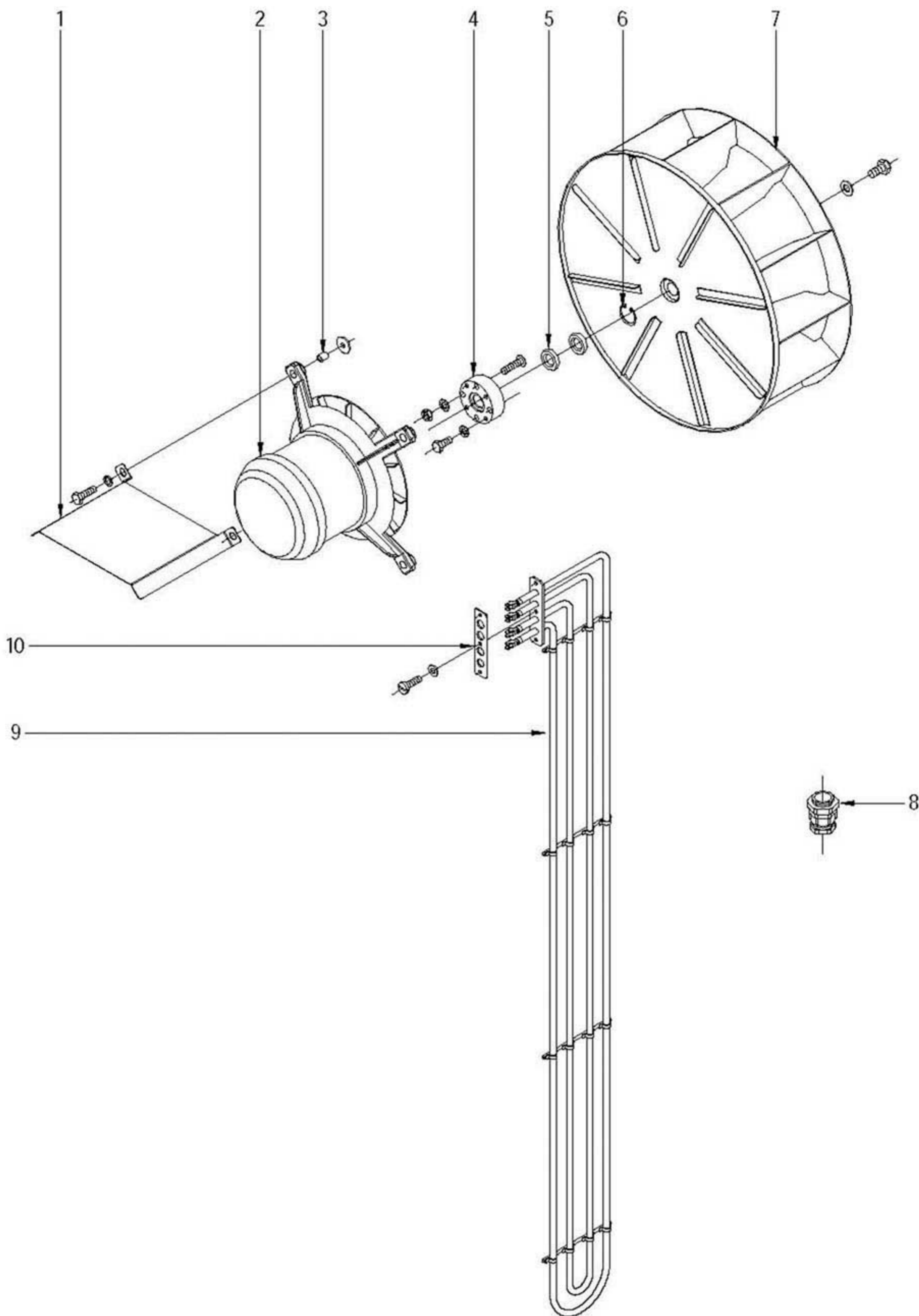

N plano	Firma	Fecha	Aparato	TURBINA	Lamina	Fagor Industrial S.Coop. FAGOR
C-1952	<i>[Signature]</i>	2007-12	HORNOS HEM; HEP-20/11		6	Orate

MOD.	HORNOS		ZONA	TURBINA				PLANO	C-1952
ITEM	CODIGO	DENOMINACION	TEXTO	HEM 20/11	HEP 20/11				NOTAS
1	T142635000	TEJADILLO MOTOR	MOTOR ROOF	2	2				
2	T493003000	MOTOR 20/21 2V 400V	MOTOR 20/21 2 SPEED 400V	2	2				
2	T493004000	MOTOR 20/21 2V 230V.	MOTOR 20/21 2V 230V.	2	2				
	Q012046000	TORN.EXA. M6X40 A.304	HEXAGONAL SCREW M.6x40	8	8				
	Q242050000	ARANDELA ABANICO A8 A.304	FAN SHAPED WASHER A.8	8	8				
	Q162050000	TUERCA EXAGONAL M8x1 INOX.	HEXAGONAL NUT M.8x1	8	8				
3	R663057000	CASQUILLO AMARRE MOTOR	CAP RETAINER	8	8				
	Q301304000	ARANDELA PLANA 23X6.5X2	FLAT WASHER 23X6.5X2	8	8				
4	R662684000	CASQUILLO RETEN	SEAL BUSHING	2	2				
	R662685000	JUNTA CASQUILLO RETEN	SEAL BUSHING GASKET	2	2				
	Q262040000	ARANDELA GROW. A6 A.304	GROWER WASHER A.6	8	8				
	Q162040000	TUERCA EXAGONAL M6	HEXAGONAL NUT M.6	8	8				
	Q232040000	ARANDELA A6	FLAT WASHER A.6	8	8				
	Q262040000	ARANDELA GROW. A6 A.304	GROWER WASHER A.6	8	8				
	Q162040000	TUERCA EXAGONAL M6	HEXAGONAL NUT M.6	8	8				
5	R662627000	RETEN 17X28X7V	RETAINER 28x17x7	4	4				
6	Q302023000	ANILLO DE SEGURIDAD D 28X1.2	SAFETY RING 28x1,2	2	2				
7	T493017000	TURBINA RECTA D350X127 FIR	STRAIGHT FAN D350X127 FIR	2	2				
	R763010000	ARANDELA SEGURIDAD HANNING	HANNING SAFETY WASHER	2	2				
	Q012063000	TORNIL. EXAGONAL M10X20 A.304	HEXAGONAL SCREW M.10x20	2	2				
8	R033002000	PRENSA ESTOPAS	WIRES PROTECTION	1	1				
9	R093002000	RESISTENCIA CONVECCION 23	ELEMENT 2000+2000W 230V	6	6				
10	R673063000	JUNTA RESISTENCIAS 10-11	ELEMENT SEAL 10-11	6	6				
	Q232040000	ARANDELA A6	FLAT WASHER A.6	18	18				
	Q242040000	ARANDELA ABANICO A6 A.304	FAN SHAPED WASHER A.6	18	18				
	Q012042000	TORNILLO EXAGONAL M6x15	HEXAGONAL BOLT M6x15	18	18				

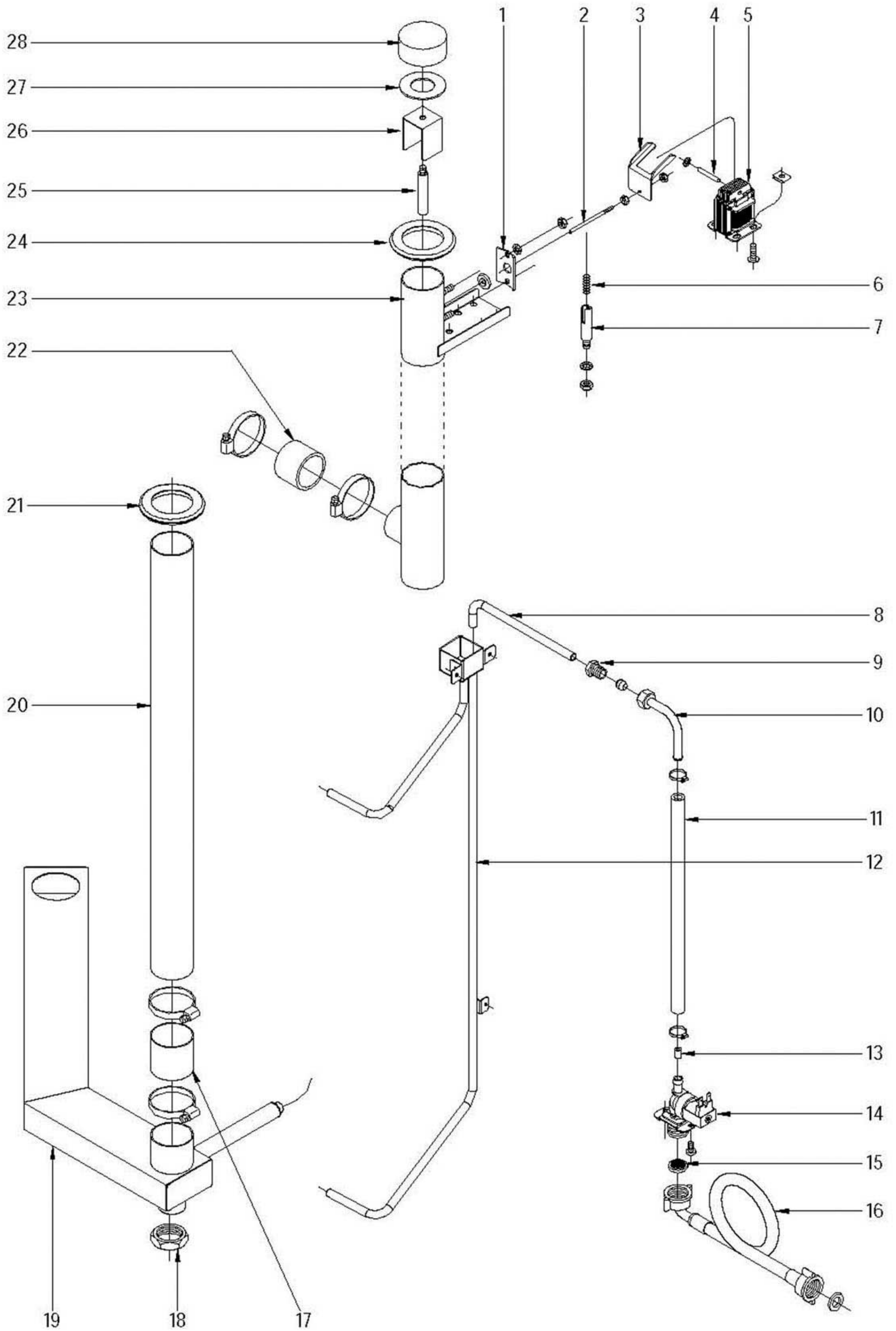

N plano	Firma	Fecha	Aparato	Lamina	Fagor Industrial S.Coop. FAGOR
C-1953	<i>[Signature]</i>	2007-12	CIRCUITO DE AGUA HORNO HEI 20/11	7	Orate

MOD.		HORNOS		ZONA	CIRCUITO DE AGUA					PLANO	C-1953
ITEM	CODIGO	DENOMINACION	TEXTO	HEI 20/11							NOTAS
1	T115105000	AMARRE CONDUCCION VAHOS	VAPOUR DUCT FASTENING	1							
	R675033000	JUNTA PALANCA ACCIONAMIENTO	JOINT	1							
	Q242030000	ARANDELA ABANICO A5 A.304	FAN SHAPED WASHER A.5	2							
	Q162030000	TUERCA EXAGONAL M5	HEXAGONAL NUT M.5	2							
2	R675014000	PALANCA ACCIONAMIENTO	MOVING ROD	1							
3	R672640000	ESCUADRA ACCIONAMIENTO	MOVING STEEL ANGLE	1							
	Q162020000	TUERCA EXAGONAL M4	HEXAGONAL NUT M.4	2							
	Q242020000	ARANDELA ABANICO A4 A.304	FAN SHAPED WASHER A.4	1							
4	R675016000	PASADOR ELECTROIMAN	PIN	1							
5	R663030000	ELECTROIMAN JOVE TIPO 501	ELECTROMAGNETIC	1							
	Q221009000	TUERCA RAPIDA SEGURID. AC.RE	NUT M.5	2							
	Q152004000	TORNILLO APLAST. M5X13 A 304	FLAT SCREW M.5x13	2							
6	Z883001000	RESORTE 20153	SPRING	1							
7	R665027000	GUIA RESORTE	PIN	1							
	Q242040000	ARANDELA ABANICO A6 A.304	FAN SHAPED WASHER A.6	1							
	Q162040000	TUERCA EXAGONAL M6	HEXAGONAL NUT M.6	1							
8	R095010000	TUBO ENTRADA INYECTOR	INJECTOR INPUT PIPE	1							
9	R695003000	MANGUITO CIERRE	CLOSING SLEEVE	1							
	R695004000	BICONO	BICONE	1							
10	R695017000	TUBO CONDUCCION AGUA	COMPLETE WATER CONDUCTIO	1							
11	3676900000	TUBO GOMA NEGRA Ø17*10	BLACK RUBBER PIPE Ø17*10	1							
	Q881302000	ABRAZADERA ELASTICA 12*20	CLAMP 12-20	2							
12	R095013000	INYECTOR COMPLETO HEI 20/11	COMPLETE INJECTOR HEI 20/11	1							
	Q412002000	REMACHE AVINOX Ø4x10MM	TUBULAR RIVET 4x7,5	3							
13	R665041000	REGULADOR 0,25L. ROJO	FLOW REGULATOR 0,25 l/min (PI	1							
14	Z701135000	E.V.SIMP.220V COD.255.208	INLET VALVE 230 V.	1							
	Q032021000	TORNILLO ALOMADO M4x10	CURVED SCREW M.4x10	4							
15	Z701132000	FILTRO DE JUNTA N-3	FILTER JOINT	1							
16	Z601114000	MANGUERA ENTRADA AGUA	WATER INLET HOSE	1							
17	R345020000	TUBO EMPALME GENERADOR	GENERATOR COUPLING TUBING	1							
	Q881307000	ABRAZADERA 40-60	CLAMP 40-60	2							

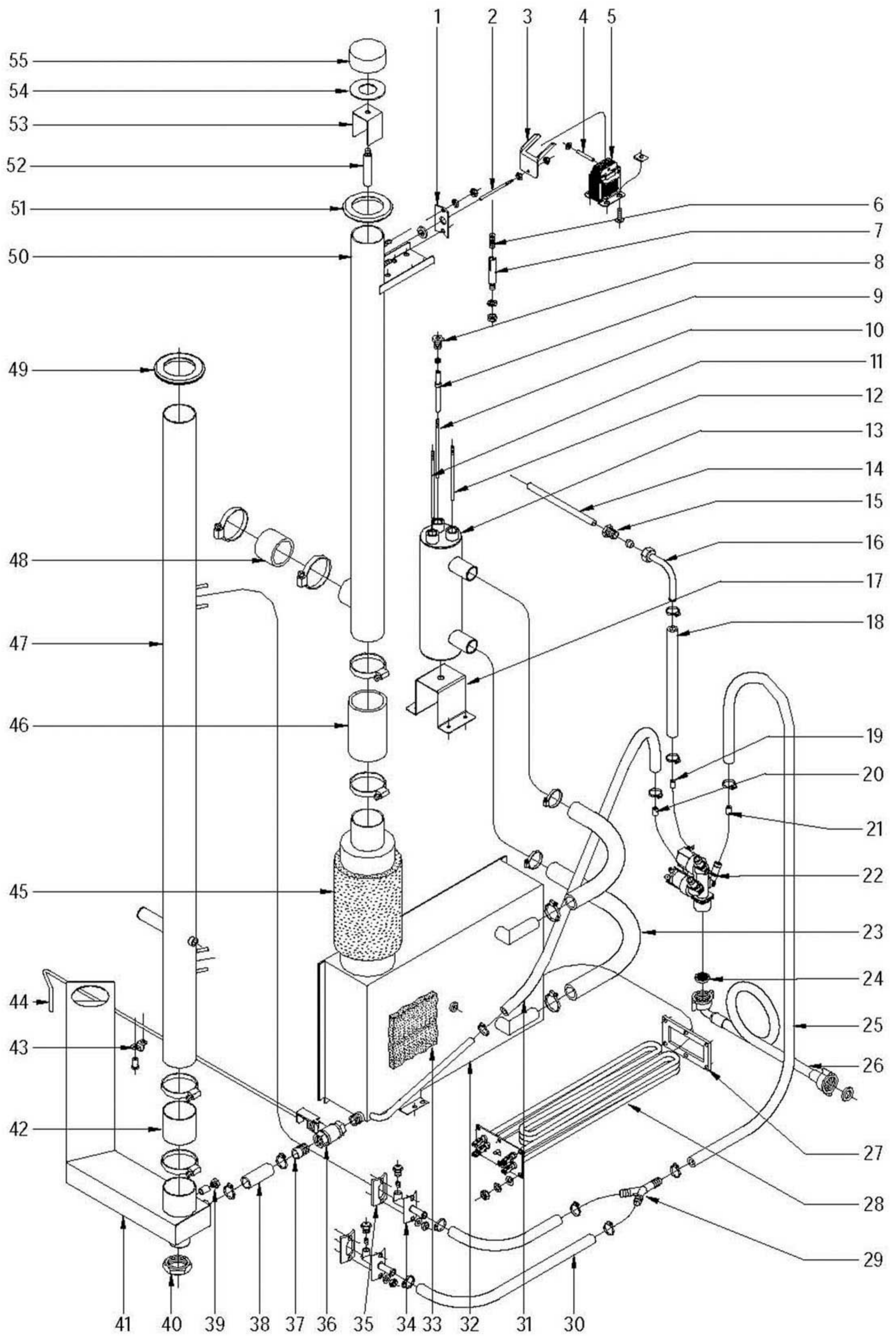

N plano

C-1954

Firma

(Signature)

Fecha

2007-12

Aparato

HORNOS HEM; HEP-20/11

CIRCUITO DE AGUA

Lamina

8

Fagor Industrial S.Coop.



Orate

MOD.	HORNOS		ZONA	CIRCUITO DE AGUA						PLANO	C-1954
ITEM	CODIGO	DENOMINACION	TEXTO	HEM 20/11	HEP 20/11						NOTAS
1	T115105000	AMARRE CONDUCCION VAHOS	VAPOUR DUCT FASTENING	1	1						
	R675033000	JUNTA PALANCA ACCIONAMIENTO	JOINT	1	1						
	Q242030000	ARANDELA ABANICO A5 A.304	FAN SHAPED WASHER A.5	2	2						
	Q162030000	TUERCA EXAGONAL M5	HEXAGONAL NUT M.5	2	2						
2	R675014000	PALANCA ACCIONAMIENTO	MOVING ROD	1	1						
3	R672640000	ESCUADRA ACCIONAMIENTO	MOVING STEEL ANGLE	1	1						
	Q162020000	TUERCA EXAGONAL M4	HEXAGONAL NUT M.4	2	2						
	Q242020000	ARANDELA ABANICO A4 A.304	FAN SHAPED WASHER A.4	1	1						
4	R675016000	PASADOR ELECTROIMAN	PIN	1	1						
5	R663030000	ELECTROIMAN JOVE TIPO 501	ELECTROMAGNETIC	1	1						
	Q221009000	TUERCA RAPIDA SEGURID. AC.RE	NUT M.5	2	2						
	Q152004000	TORNILLO APLAST. M5X13 A 304	FLAT SCREW M.5x13	2	2						
6	Z883001000	RESORTE 20153	SPRING	1	1						
7	R665027000	GUIA RESORTE	PIN	1	1						
	Q242040000	ARANDELA ABANICO A6 A.304	FAN SHAPED WASHER A.6	1	1						
	Q162040000	TUERCA EXAGONAL M6	HEXAGONAL NUT M.6	1	1						
8	R345058000	RACORD	ELECTRODES ANCHORING ADAP	3	3						
	Q163020000	TUERCA EXAGONAL M4	HEXAGONAL NUT M.4	6	6						
9	R345059000	GUIA AISLANTE	ELECTRODE INSULATOR GUIDE	3	3						
10	R345063000	ELECTRODO NIVEL BAJO	LOW LEVEL ELECTRODE	1	1						
11	R345064000	ELECTRODO DE MASA	EARTH ELECTRODE L=131	1	1						
12	R345060000	ELECTRODO NIVEL ALTO	HIGH LEVEL ELECTRODE	1	1						
13	T325040000	CUERPO NIVELES COMPLETO	COMPLETE LEVELS BODY	1	1						
	Q232040000	ARANDELA A6	FLAT WASHER A.6	1	1						
	Q262040000	ARANDELA GROW. A6 A.304	GROWER WASHER A.6	1	1						
	Q162040000	TUERCA EXAGONAL M6	HEXAGONAL NUT M.6	2	2						
14	R665024000	TUBO CONDUCCION INYECTOR	INJECTOR CONDUCTION TUBING	1	1						
15	R695003000	MANGUITO CIERRE	CLOSING SLEEVE	1	1						
	R695004000	BICONO	BICONE	1	1						
16	R695017000	TUBO CONDUCCION AGUA	COMPLETE WATER CONDUCTIO	1	1						
17	R025032000	CHAPA CUERPO NIVELES E102011	PLATE BODY LEVELS E102011	1	1						

MOD.	HORNOS		ZONA	CIRCUITO DE AGUA						PLANO	C-1954
ITEM	CODIGO	DENOMINACION	TEXTO	HEM 20/11	HEP 20/11						NOTAS
18	3676900000	TUBO GOMA NEGRA Ø17*10	BLACK RUBBER PIPE Ø17*10	1	1						
	Q881302000	ABRAZADERA ELASTICA 12*20	CLAMP 12-20	2	2						
19	R665041000	REGULADOR 0,25L. ROJO	FLOW REGULATOR 0,25 l/min (PI	1	1						
20	P443042000	REGULADOR 3L. VERDE 254.023	FLOW REDUCER 3 l/min (BLACK)	1	1						
21	Z601156000	REGULADOR 8L RO. 254.034	FLOW REDUCER 8 l/min (RED)	1	1						
22	Z611123000	E.V. TRIPLE COD.255.641	ELECTROVALVE	1	1						
	Q032021000	TORNILLO ALOMADO M4x10	CURVED SCREW M.4x10	4	4						
23	3715600000	TUBO SILICONA FORRADO 26X18	LINED SILICONE TUBE 26X18	2	2						
	Q881305000	ABRAZADERA 25-40	CLAMP 25-40	4	4						
24	Z701132000	FILTRO DE JUNTA N-3	FILTER JOINT	2	2						
25	3676900000	TUBO GOMA NEGRA Ø17*10	BLACK RUBBER PIPE Ø17*10	1	1						
	Q881302000	ABRAZADERA ELASTICA 12*20	CLAMP 12-20	2	2						
26	Z601114000	MANGUERA ENTRADA AGUA	WATER INLET HOSE	1	1						
27	R145012000	JUNTA CIERRE RESISTENCIAS	JOINT	2	2						
28	R143000000	RESISTENCIA 3000WX3	HEATING ELEMENT 3000W.x3 23	2	2						
	Q163030000	TUERCA EXAGONAL M5 LATON	HEXAGONAL NUT M.5	12	12						
	Q242030000	ARANDELA ABANICO A5 A.304	FAN SHAPED WASHER A.5	12	12						
29	Z201106000	RACORD EN Y	UNION "Y"	1	1						
30	3676900000	TUBO GOMA NEGRA Ø17*10	BLACK RUBBER PIPE Ø17*10	2	2						
	Q881302000	ABRAZADERA ELASTICA 12*20	CLAMP 12-20	4	4						
31	3676900000	TUBO GOMA NEGRA Ø17*10	BLACK RUBBER PIPE Ø17*10	2	2						
	Q881302000	ABRAZADERA ELASTICA 12*20	CLAMP 12-20	4	4						
32	R675024000	GENERADOR DE VAPOR 20/11	STEAM BOILER	1	1						
33	R345011000	AISLANTE GENERADOR E-10-20/11	FRONT INSULATION BOILER	1	1						
34	R015007000	CONDUCCION VAHOS COMPLETO	CONNECTION	2	2						
	Z651931000	TOBERA ACLARADO	INJECTOR	2	2						
	Z651932000	RODETE	RUNNER	2	2						
	Q162030000	TUERCA EXAGONAL M5	HEXAGONAL NUT M.5	2	2						
	Q242030000	ARANDELA ABANICO A5 A.304	FAN SHAPED WASHER A.5	2	2						
35	R345108000	JUNTA DE VAHOS 5102805	JOINT	2	2						
36	R015034000	CUERPO GRIFO VACIADO	BOILER DRAIN TAP	1	1						

MOD.		HORNOS		ZONA	CIRCUITO DE AGUA					PLANO	C-1954
ITEM	CODIGO	DENOMINACION	TEXTO	HEM 20/11	HEP 20/11						NOTAS
37	R345014000	MANGUITO GRIFO VACIADO	EMPTYING TAP SLEEVE	1	1						
	Q881304000	ABRAZADERA 20-32	CLAMP 20-32	2	2						
38	3715600000	TUBO SILICONA 26X18	SILICONE PIPE 26X18	1	1						
	Q881305000	ABRAZADERA 25-40	CLAMP 25-40	4	4						
39	R662629000	RACORD CIERRE SONDA	PROBE CLOSING ADAPTOR	1	1						
	3712400000	TUBO SILICONA NEGRO D 8*3	BLACK SILICONE PIPE D 8*3	1	1						
40	Q223014000	CONTRATUERCA 1 LATON	LOCK NUT 1 PUL	1	1						
41	-----	TUBO DESA. (CUERPO INTERIOR)	DRAIN PIPE. (INNER BODY)	1	1						
42	R345020000	TUBO EMPALME GENERADOR	GENERATOR COUPLING TUBING	1	1						
	Q881307000	ABRAZADERA 40-60	CLAMP 40-60	2	2						
43	Q901306000	GRAPA METALICA DOS PIES	TAP HANDLE FASTENING	1	1						
	Q412002000	REMACHE AVINOX Ø4x10mm	TUBULAR RIVET 4x7,5	2	2						
44	R342803000	PALANCA GRIFO VACIADO	DRAIN TAP LEVER	1	1						
45	T115066000	AISLANTE CHIMENEA 10-20/11	FLUE PIPE INSULATION 10-20/11	1	1						
46	R345020000	TUBO EMPALME GENERADOR	GENERATOR COUPLING TUBING	1	1						
	Q881307000	ABRAZADERA 40-60	CLAMP 40-60	2	2						
47	R675043000	CHIMENEA COMPLETA 20/11E	COMPLETE FLUE PIPE 20/11E	1	1						
48	3715800000	TUBO SILICONA Ø43*51	SILICONE TUBE Ø43*51	1	1						
	Q881307000	ABRAZADERA 40-60	CLAMP 40-60	2	2						
49	R662813000	PASAMUROS CHIMENEA 101003361	FEEDTHROUGH FLUE PIPE 1010	1	1						
50	R095004000	CHIMENEA COMPLETA 20/11 E-M-P	COMPLETE CHIMNEY	1	1						
51	R662813000	PASAMUROS CHIMENEA 101003361	FEEDTHROUGH FLUE PIPE 1010	1	1						
52	R675008000	UNION RETENCION VAPORES	MOVING ROD CHIMNEY	1	1						
53	R675005000	GUIA RETENCION VAPORES	MOVING GUIDE	1	1						
54	R675007000	JUNTA RETENCION VAPORES	RUBBER SEAL	1	1						
55	R675006000	RETENCION DE VAPORES	CLOSE CHIMNEY	1	1						

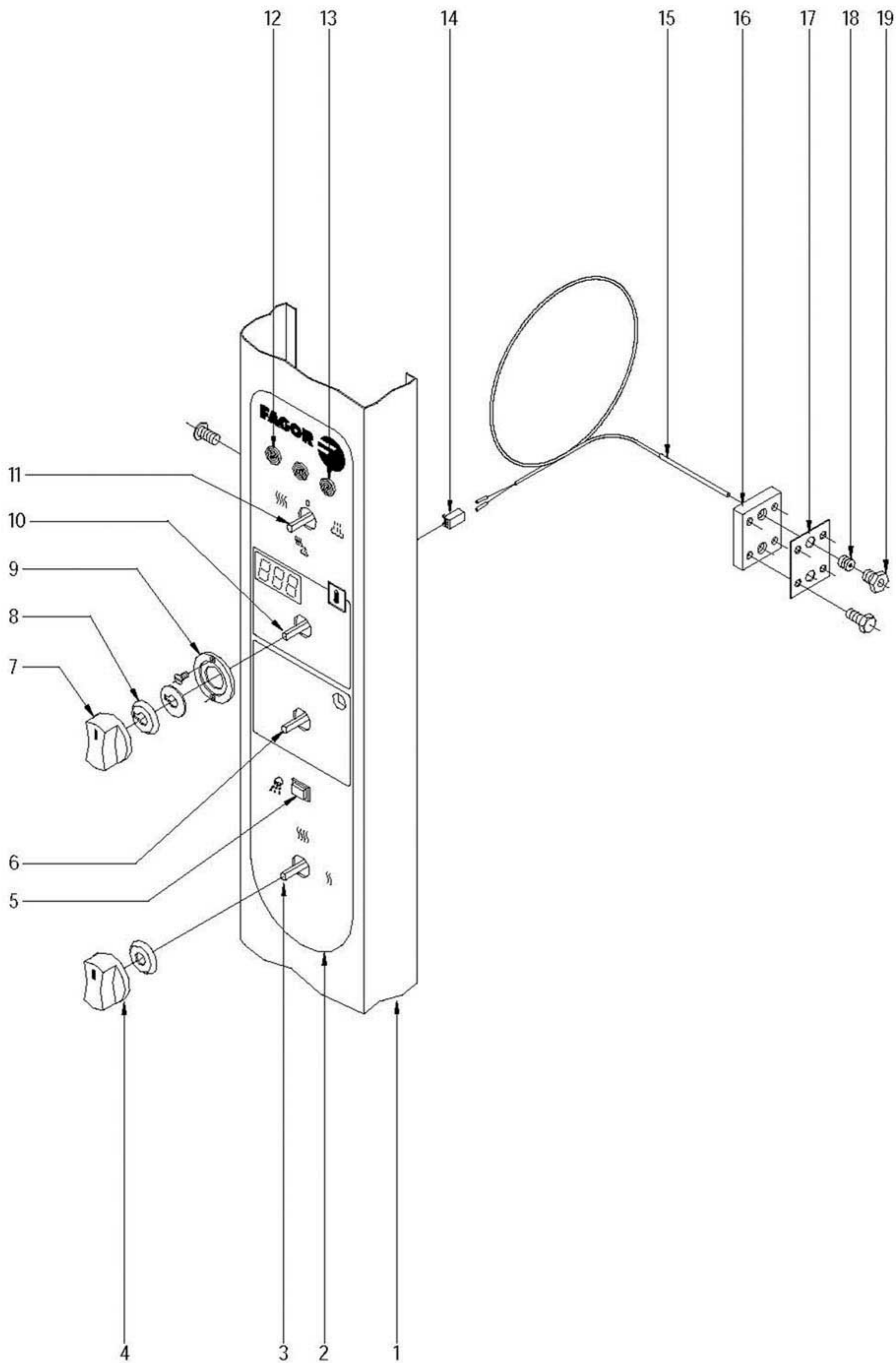

N plano

C-1955

Firma

(Signature)

Fecha

2007-12

Aparato

SISTEMA ELECTRICO PORTAMANDOS
HORNO HEI-20/11

Lamina

9

Fagor Industrial S.Coop.
Orote

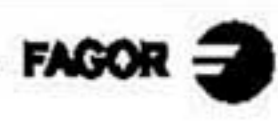

MOD.	HORNOS	ZONA	PARTE ELECTRICA PORTAMANDOS	PLANO	C-1955
------	--------	------	-----------------------------	-------	--------

ITEM	CODIGO	DENOMINACION	TEXTO	HEI 20/11							NOTAS
1	T102817000	PANEL PORTAMANDOS HGC-20/11	CONTROL PANEL	1							
	Q152004000	TORNILLO APLAST. M5X13 A 304	FLAT SCREW M.5x13	3							
	R692806000	SOPORTE COMPONENTES HMI	SUPPORT	1							
	R663036000	FIJACION CIRCUITO	CIRCUIT BINDINGS	4							
	R693011000	RESISTENCIA 1K8 4W	HEATING ELEMENT 1K8 (4KW)	1							
2	R703042000	SERIGRAFIA HEI-10/11	SERIGRAPHY HEI-10 / 11	1							
3	R753000000	CONMUTADOR DE POTENCIA	POWER SWITCH	1							
4	R663062000	BOTÓN DE MANDO COMPLETO	COMPLETE CONTROL BUTTON	3							
	R663046000	JUNTA CONMUTADOR	SWITCH JOINT	3							
5	R663032000	PULSADOR L41M8M959F	PUSH BUTTON	1							
6	R723000000	TEMPORIZADOR MANUAL	TIMER	1							
7	R663063000	BOTÓN DE MANDO COMPLETO	KNOB ELECTRONIC	1							
8	R663045000	JUNTA POTENCIOMETRO	RUBBER SEAL	1							
	R662810000	ARANDELA GUIA	GUIDE WASHER	1							
9	R662809000	GUIA BOTON DE MANDO	KNOB GUIDE	1							
	Q151346000	TORNILLO AVELLANADO M3x5	BOLT M.3x5	2							
10	R743013000	TERMOSTATO ELECTRONICO 270°C	THERMOSTAT 0-270°C	1							
11	R693004000	CONMUTADOR DE FUNCIONES	SWITCH	1							
12	R693056000	PILOTO AMBAR 41227000A4	AMBAR PILOT 41227000A4	2							
13	R693055000	PILOTO VERDE 41227000C7	GREEN PILOT 41227000C7	1							
14	R663092000	CONECTOR 2 VIAS	2-WAY CONNECTOR	1							
15	R663090000	CONJUNTO TERMOPAR	THERMOCOUPLE SET	1							
16	R662659000	APOYO RACORD SONDA	PROBE RACORD SUPPORT	1							
17	R692811000	JUNTA PASAMUROS DOBLE	DOUBLE FEEDTHROUGH GASKE	1							
18	R662652000	BICONO CIERRE SONDA	PROBE CLOSING BICONE	1							
19	R662629000	RACORD CIERRE SONDA	PROBE CLOSING ADAPTOR	1							
	Q032021000	TORNILLO ALOMADO M4X10	CURVED SCREW M.4x10	4							
	Q232020000	ARANDELA A-4	FLAT WASHER A.4	4							

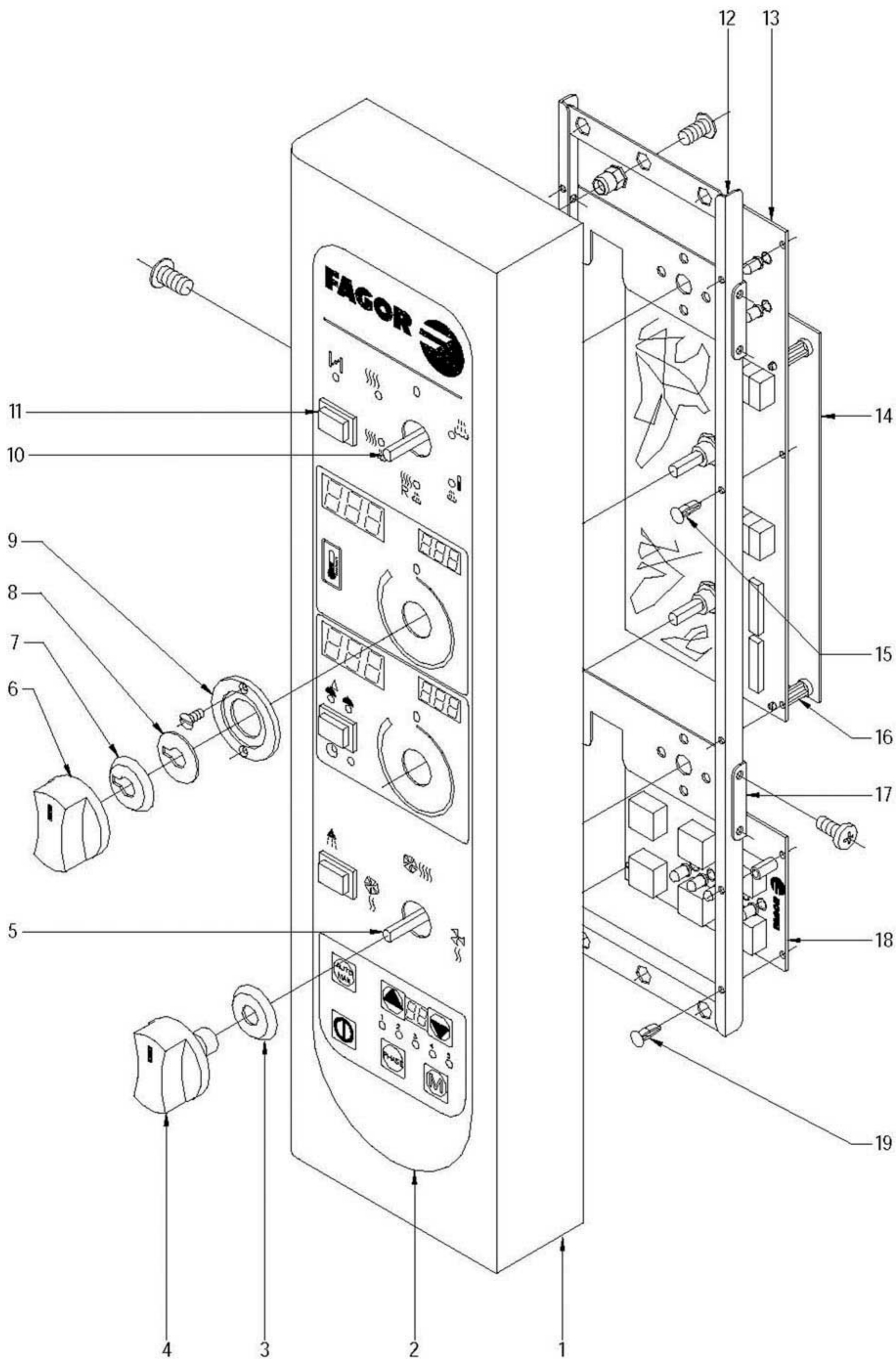

N plano

C-1956

Firma

Anna Benja

Fecha

2007-12

Aparato

HORNOS HEM; HEP-20/11

SISTEMA ELECTRICO PORTAMANDOS

Lamina

10

Fagor Industrial S.Coop.

Orate

FAGOR



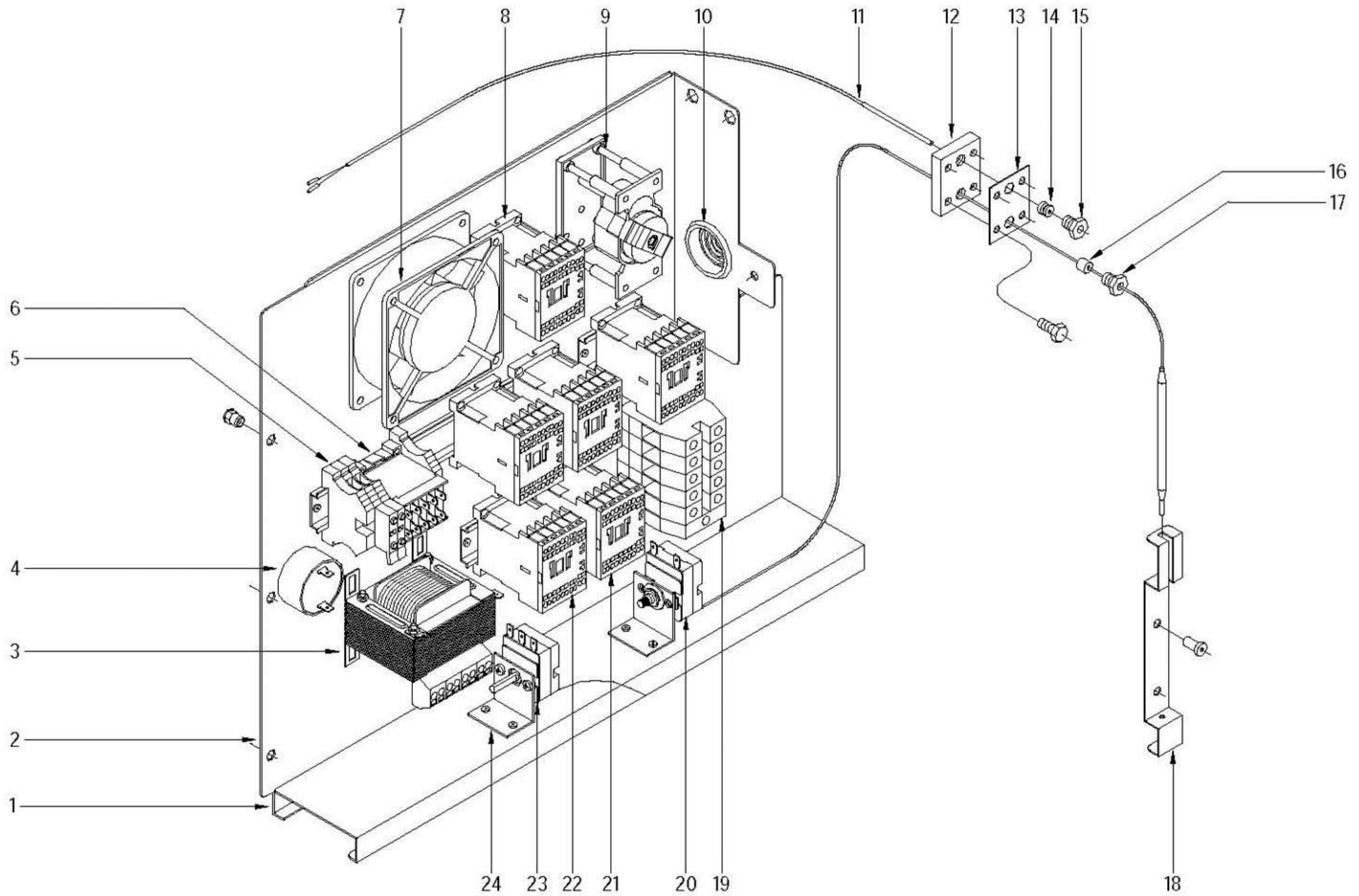

N plano	Firma	Fecha	Aparato	Lamina	Fagor Industrial S.Coop. FAGOR
C-1957	<i>[Signature]</i>	2007-12	CUADRO ELECTRICO HORNO HEI-20/11	11	Date

MOD.	HORNOS		ZONA	CUADRO ELECTRICO					PLANO	C-1957
ITEM	CODIGO	DENOMINACION	TEXTO	HEI 20/11						NOTAS
1	R723101000	CONTRAGUIA CUADRO HCG	SWITCHBOARD COUNTERGUIDE	1						
	Q412002000	REMACHE AVINOX Ø4x10MM	TUBULAR RIVET 4x7,5	7						
2	R663081000	PANEL CUADRO 6-10-20/11 ELECT	SWITCHBOARD PANEL 6-10-20/1	1						
	Q221342000	REMACHE EXAGONAL M5	HEXAGONAL RIVET M.5	3						
3	R503005000	TRANSFORMADOR	TRANSFORMER	1						
	Q032021000	TORNILLO ALOMADO M4x10	CURVED SCREW M.4x10	4						
	Q162020000	TUERCA EXAGONAL M4	HEXAGONAL NUT M4	4						
4	R693067000	ZUMBADOR	BUZZER	1						
5	R073005000	BORNAS PORTA FUSIBLES	FUSE SUPPORT	2						
	Z263303000	TOPE FINAL	END BUFFER 10	1						
6	Z683087000	CONTACTOR 3TF20 01-3AL2 230	CONTACTOR 230V 50-60 Hz	1						
	Z263303000	TOPE FINAL	END BUFFER 10	1						
7	Z103066000	VENTILADOR 230V.50-60HZ	FAN 230V 50/60HZ	1						
8	Z743009000	CONTAC. SIRIUS 3RT10 16-2AP02	SIRIUS 3RT10, 16-2APO2 CONTA	1						
9	R763006000	PROGRAMADOR INVERSION GIRO	PROGRAMMER	1						
	Z123018000	GUIA CONTACTOR L-55	CONTACTOR GUIDE L=55	1						
10	N103013000	PASA CABLES	BUSHING	1						
11	R663090000	CONJUNTO TERMOPAR	THERMOCOUPLE SET	1						
12	R662659000	APOYO RACORD SONDA	PROBE RACORD SUPPORT	1						
13	R692811000	JUNTA PASAMUROS DOBLE	DOUBLE FEEDTHROUGH GASKE	1						
14	R662652000	BICONO CIERRE SONDA	PROBE CLOSING BICONE	1						
15	R662629000	RACORD CIERRE SONDA	PROBE CLOSING ADAPTOR	1						
	Q032021000	TORNILLO ALOMADO M4X10	CURVED SCREW M.4x10	4						
	Q232020000	ARANDELA A-4	FLAT WASHER A.4	4						
16	R662662000	JUNTA CIERRE BULBO LIMITADOR	LIMITING BULB CLOSING JOINT	1						
17	R662629000	RACORD CIERRE SONDA	PROBE CLOSING ADAPTOR	1						
	Q412002000	REMACHE AVINOX Ø4x10MM	TUBULAR RIVET 4x7,5	4						
18	R662683000	SOPORTE BULBO	LIMITING BULB HOLDER	1						
	Q412002000	REMACHE AVINOX Ø4x10MM	TUBULAR RIVET 4x7,5	2						

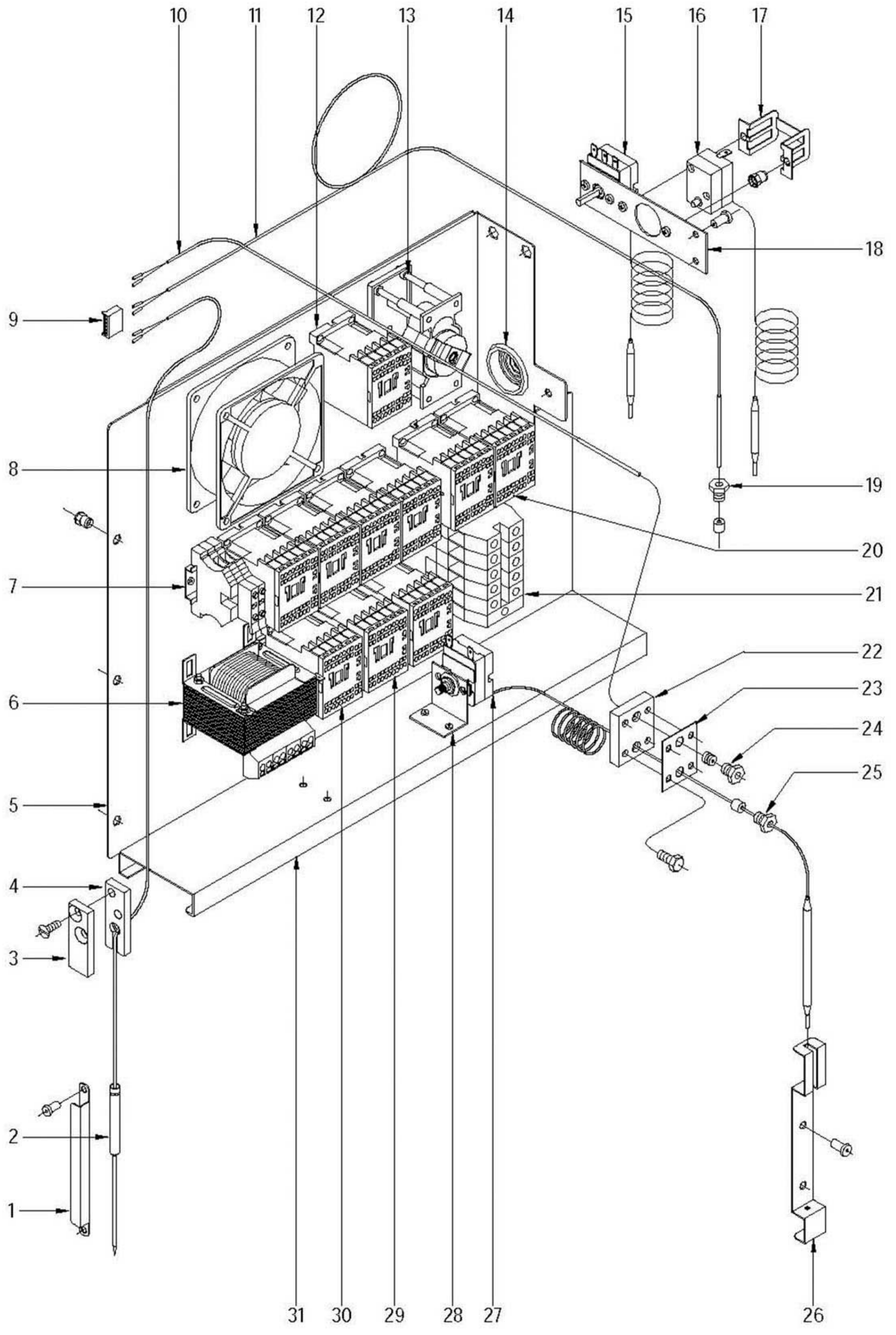

N plano	Firma	Fecha	Aparato	CUADRO ELECTRICO	Lamina	Fagor Industrial S.Coop. FAGOR
C-1958	<i>[Signature]</i>	2007-12	HORNOS HEM; HEP-20/11		12	Orate

MOD.		HORNOS		ZONA	CUADRO ELECTRICO					PLANO	C-1958
ITEM	CODIGO	DENOMINACION	TEXTO	HEM 20/11	HEP 20/11						NOTAS
1	R092633000	RETENEDOR DE SONDA	CORE PROBE RETAINER	3	3						
	Q412002000	REMACHE AVINOX Ø4x10MM	TUBULAR RIVET 4x7,5	3	3						
2	R673076000	CONJUNTO SONDA NUCLEO J XX/1	MEAT PROBE SET	1	1						
	Q221341000	REMACHE EXAGONAL M4	HEXAGONAL RIVET M.4	2	2						
3	T133037000	TAPA SUJECION SONDA	COVER CORE PROBE	1	1						
4	T133036000	BASE SUJECION SONDA	FIXING CORE PROBE	1	1						
5	R663081000	PANEL CUADRO 6-10-20/11 ELECT	SWITCHBOARD PANEL 6-10-20/1	1	1						
	Q221342000	REMACHE EXAGONAL M5	HEXAGONAL RIVET M.5	3	3						
6	R503005000	TRANSFORMADOR	TRANSFORMER	1	1						
	Q032021000	TORNILLO ALOMADO M4x10	CURVED SCREW M.4x10	4	4						
	Q162020000	TUERCA EXAGONAL M4	HEXAGONAL NUT M4	4	4						
7	R073005000	BORNAS PORTA FUSIBLES	FUSE SUPPORT	2	2						
	Z263303000	TOPE FINAL	END BUFFER 10	2	2						
8	Z103066000	VENTILADOR 230V.50-60HZ	FAN 230V 50/60HZ	1	1						
9	R663093000	CONECTOR 6 VIAS	6-WAY CONNECTOR	1	1						
10	R663090000	CONJUNTO TERMOPAR	THERMOCOUPLE SET	1	1						
11	R663089000	CONJ. TERMOPAR VAPOR HME/P	STEAM THERMOCOUPLE ASSEM	1	1						
12	Z743009000	CONT.SIRIUS 3RT10 16-2AP02	SIRIUS 3RT10, 16-2APO2 CONTA	1	1						
13	R763006000	PROGRAMADOR INVERSION GIRO	PROGRAMMER	1	1						
	Z123018000	GUIA CONTACTOR L-55	CONTACTOR GUIDE L=55	1	1						
14	N103013000	PASA CABLES	BUSHING	1	1						
15	R343100000	TERMOSTATO CONDOC. VAPOR	STEAM CONDUCTION THERMOS	1	1						
16	Z213014000	LIMITADOR TECASA P.	TECASA LIMITER THERMOSTAT	1	1						
17	Z203060000	AMARRE LIMITADOR TECASA	TECASA LIMITER ANCHORING	1	1						
	Q221341000	REMACHE EXAGONAL M4	HEXAGONAL RIVET M.4	2	2						
18	R673077000	SOPORTE AMARRE TERMOSTATOS	THERMOSTAT ATTACHMENT SU	1	1						
	Q412002000	REMACHE AVINOX Ø4x10MM	TUBULAR RIVET 4x7,5	2	2						
19	R662629000	RACORD CIERRE SONDA	PROBE CLOSING ADAPTOR	1	1						
	3712400000	TUBO SILICONA NEGRO D 8*3	BLACK SILICONE PIPE D 8*3	1	1						
20	Z203050000	CONTACTOR SIRIUS 3R 230V.50-60	CONTACTOR 3RT-1016-21P01	6	6						
	R693009000	GUIA CONTACTOR L-250	CONTACTOR GUIDE L=250	1	1						

3N~50.60Hz 380/415V

HEI - 10 / 11,

HEI - 20 - 11

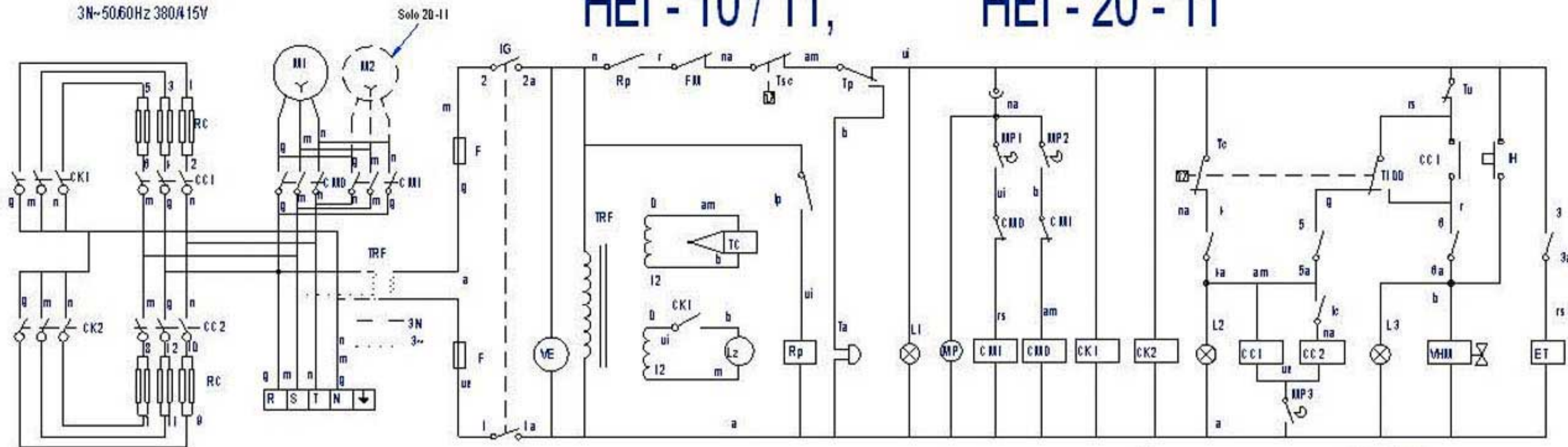

3~50.60Hz 220V

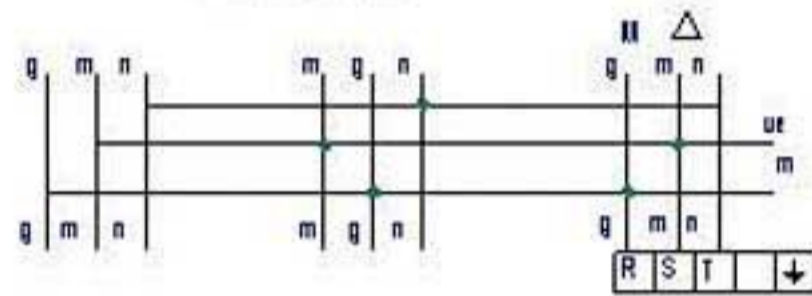

- P = Door's switch
- IG = General switch
- F = Fuse
- CMD = Right Motor's relay
- CMI = Left Motor's relay
- VMV = Steamer's solenoid
- DN = Water level control
- TM = Motor's thermal protection
- TSM = Steamer's security thermostat
- TSC = Connection's security thermostat
- LZ = Indoor light
- VHM = Humidity water solenoid
- CE = Electronic main control
- RV = Steamer element
- VE = Control panel's fan
- Tr = Chimney selector

- TRF, TRF I = Transformer
- ET = Chimney solenoid
- lc = Power reduction switch
- VCN = Steamer condenser solenoid
- TV = Steam probe
- TC = Connection probe
- TN = Food probe
- M = Motor
- CC1, CC2 = Heating air relays
- CV1, CV2 = Heating water relays
- CK1, CK2, K1, K2 = Elements relays
- TCN = Steam condenser thermostat
- H = Humidity switch
- T = Timer or Food probe selector
- RC = Heating element
- MP = Timer Motor's insertion

- am = amarillo-yellow-jaune
- a = azul-blue-bleu
- b = blanco-white-blanc
- g = gris-grey-gris
- ue = verde-green-vert
- na = naranja-orange-orange
- r = rojo-red-rouge
- m = marron-brown-marron
- n = negro-black-noir
- rs = rosa-pink-rose
- ui = violeta-violet-violet
- am&ue = amarilloverde-yellowgreen-jaunevert

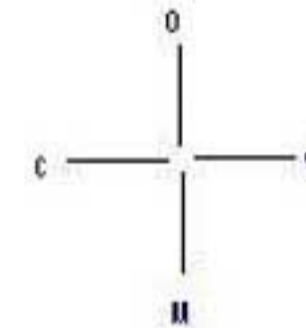

IG	1 1a	2 2a	3 3a	4 4a	5 5a	6 6a
VAPOR		X			X	X
MOTOR	X	X		X		X
CONVECCION	X	X	X	X		

R1 030+1 000

- T100: Termostato de 100°C
- Rc: Resistencia de calentamiento
- IG: Interruptor general
- Lz: Luz interior
- F: Fusible
- CMD, CMI: Contactor motor
- VHM: Electrovalvula humidificador
- IP: Interruptor puerta
- FM: Térmico motor
- TP: Temporizador manual
- TSC: Termostato seguridad conexión
- TV: Termostato vapor
- TRF: Transformador

- M: Motor
- Tc: Termostato conexión
- CK1, CC1: Contactor calentamiento
- ET: Electroimán de apertura de tiro
- C: Condensador
- L1: Lámpara marcha
- L2: Lámpara calentamiento
- L3: Lámpara humidificador
- Ta: Timbre avisador
- FI: Filtro de interferencias
- IH: Pulsador de humidificador
- VE: Ventilador cuadro eléctrico
- Rp: Reé puerta
- MP: Programador inmersión motor

Esquema teorico HEI 10-11, HEI 20-11		3 ~ 50.60Hz 230 V		
Esquema teorico HEI 10-11, HEI 20-11		3 ~ 50.60Hz 400 V	R-703041	
Nº	Plano	Material	Nº Clasificado	Acabado
Nº	Modificación	Propuesta de	Fecha	Todas las generales
1	Introducir HEI-20-11	M. Mallo	31-05-2001	<div style="display: flex; justify-content: space-between;"> 50-400± 500± </div>
Dibujado		Fecha		
Proyectado		13/11/98		
Comprobado				
Escala		Fagor Industrial, Coop. E.I. Miraflores		Mecanizado especial
HORNOS				Plano número
				HC-76614 - 1
				Distribuye al N°
				Distribuido por

3N ~ 50/60Hz 380/415V

MODELO HEM-20/11 HEP-20/11

HEM-20/21 HEP-20/21

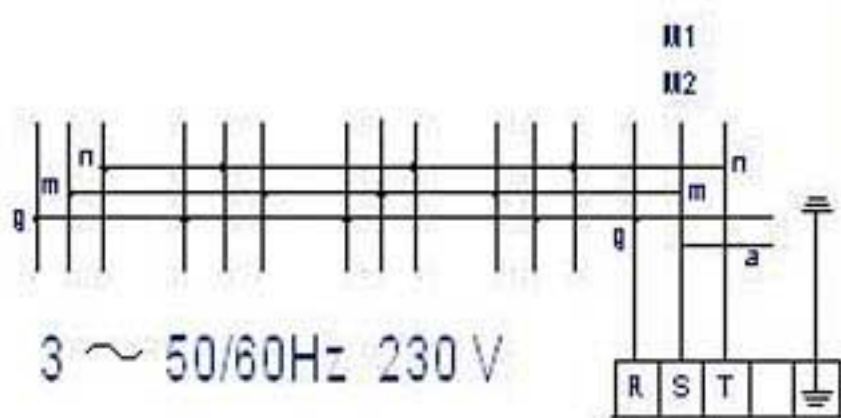
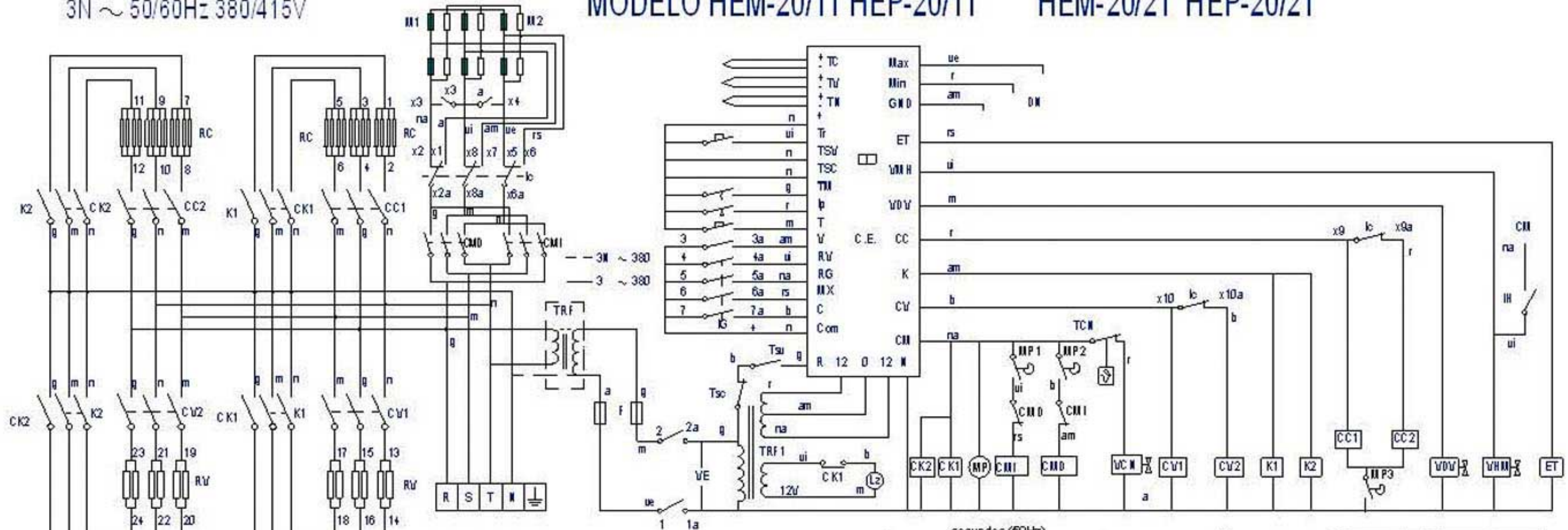

- IP - Doors switch
- IG - General switch
- F - Fuse
- CMD - Right Motors relay
- CM1 - Left Motors relay
- V0V - Steamer's solenoid
- DN - Water level control
- TM - Motor's thermal protection
- TSC - Steamer's security thermostat
- TSC - Convector's security thermostat
- LZ - Indoor light
- VHM - Humidity water solenoid
- CE - Electronic milk control
- RV - Steamer element
- VE - Control panel fan
- Tr - Chimney selector
- TRF, TRF1 - Transformer
- ET - Chimney solenoid
- IC - Power indicator switch
- VCN - Steamer condenser solenoid
- TV - Steam probe
- TC - Convector probe
- TN - Food probe
- M1, M2 - Motor
- CC1, CC2 - Heating air relays
- CV1, CV2 - Heating water relays
- CK1, CK2, K1, K2 - Elements relays
- TCN - Steam condenser thermostat
- IH - Humidity switch
- T - Timer or Food probe selector
- RC - Heating element
- MP - Timer Motor's relay

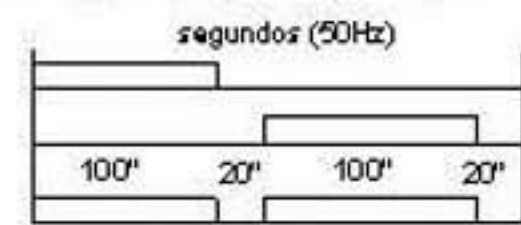

- am - amarillo-ye low/yat/le
- a - azul/bleu-bleu
- b - blanco/blanc
- g - gris/gris-grit
- ve - verde/vert-vert
- oa - naranja/orange-orange
- r - rojo/red-rotge
- m - marron/brown-marron
- s - negro/black-noir
- rs - rosa/pink-rose
- vl - violeta/violet-bleu

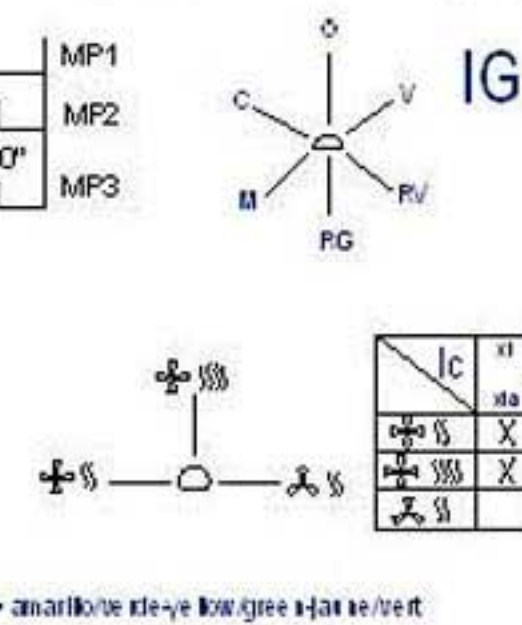

Modo	1	2	3	4	5	6	7
OFF							
VAPOR	X	X	X				
REG VAPOR	X	X		X			
HELECTRIC	X	X			X		
MIXTO	X	X				X	
CONVECCION	X	X					X

IC	x1	x2	x3	x4	x5	x6	x7	x8	x9	x10
	x1a	x2a	x3a	x4a	x5a	x6a	x7a	x8a	x9a	x10a
+	X		X	X		X	X			
-	X		X	X		X	X			X
0		X			X			X		

R143032000

ESQUEMA TEORICO HME/P 20/11- 20/21		R143032000	
Nº Pieza	Carta	Materia	Nº Clasificación
Nº Modificación	Propuesta de		Fecha
			Tolerancias generales
			<±
			5-25±
			25-50±
			50-100±
			>100±
			∞±
Dibujado	Fecha	Mecanizado en metal	
Proyectado	17-10-2004	FAGOR	
Comprobado	17-10-2004	Fagor Industrial, Coop. E.L., Megalga	
Escala	Horno Mixto HME HMP		Plazo número HC-77660
Distribuye al N°			no72270
Distribuidor			

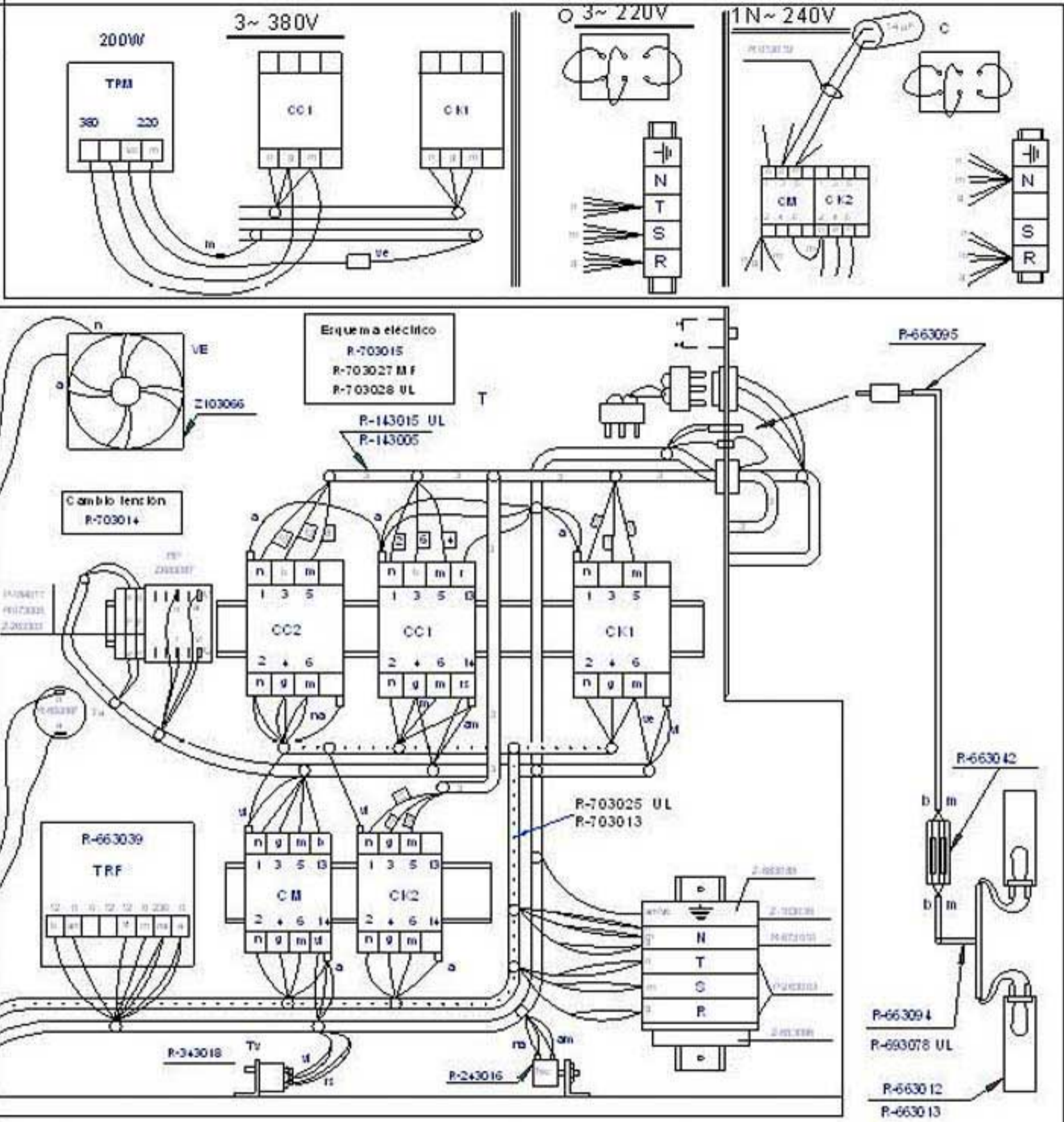
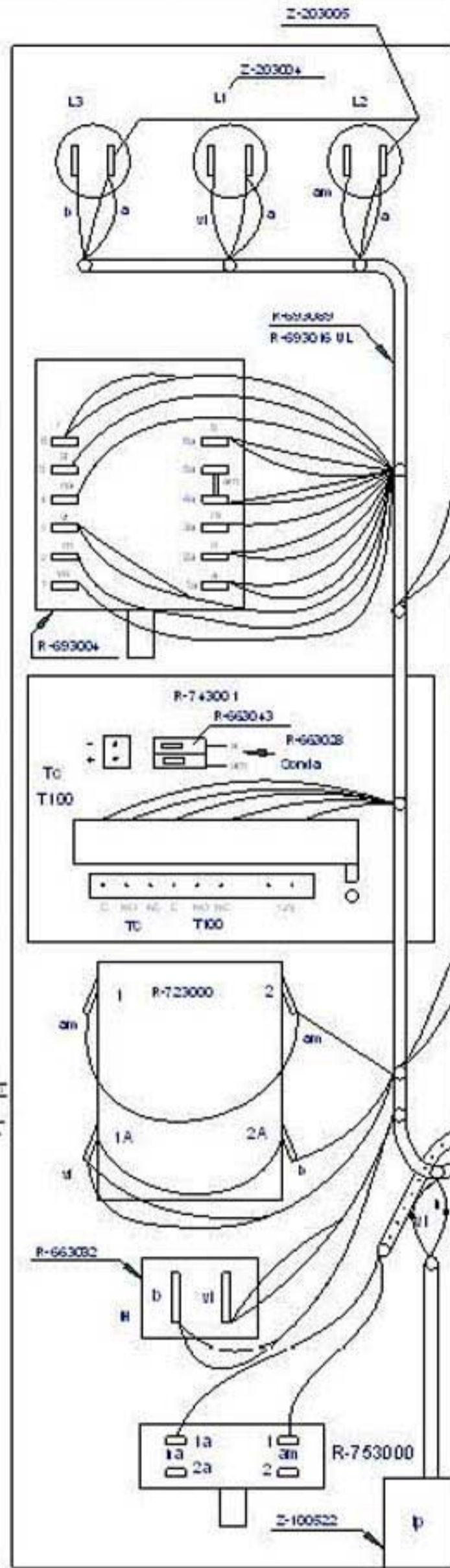
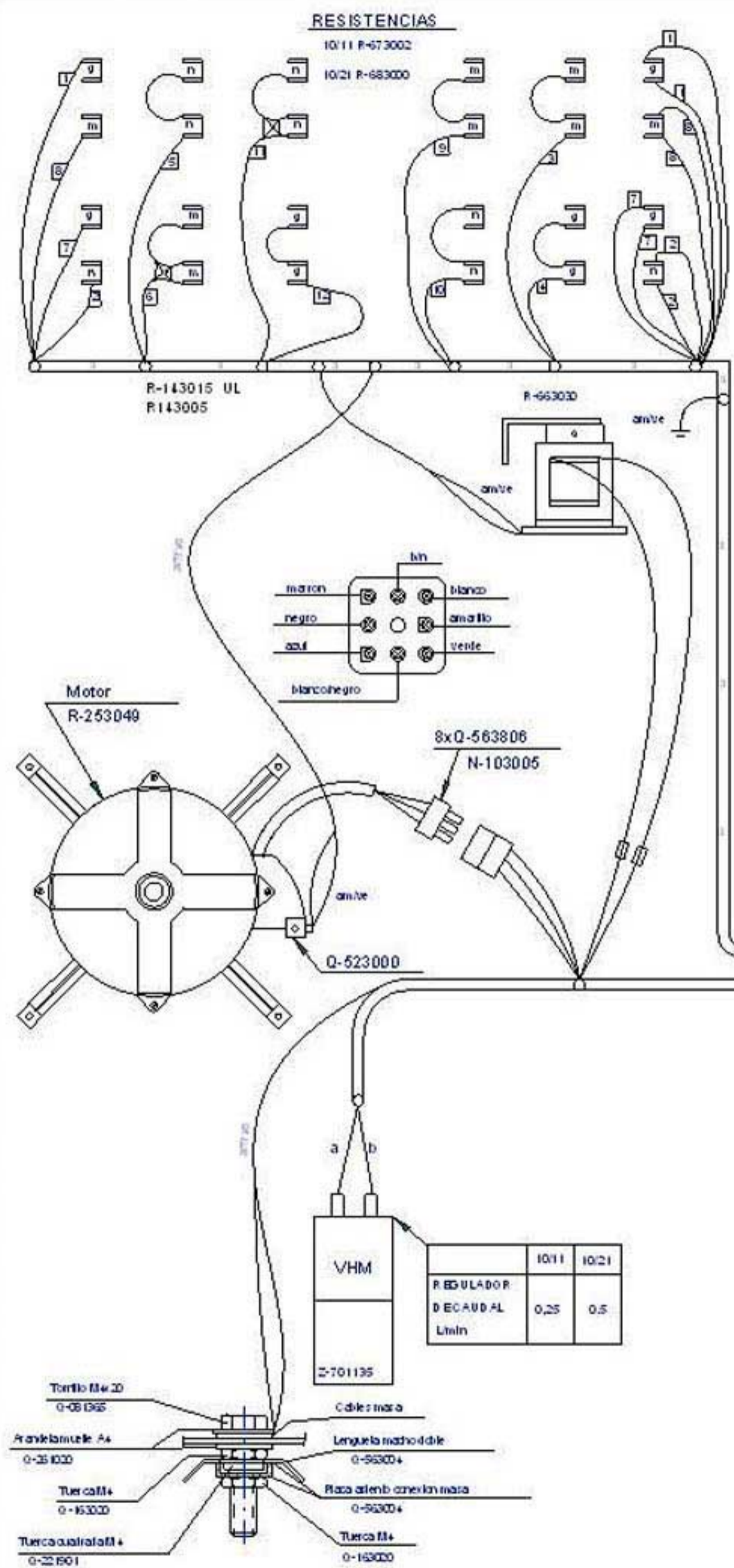

Plano mont HMI-10-11/20-21 3N 380V		R-703016	
Nº Pieza	Cant.	Material	Nº Clasificación
Nº Modificación	Propuesta de		Fecha
1	Introducir Rp		26.2/2002
2	Cambio denominación		20-02-2004
Dibujado		Fecha	Mecanizado en metal
Proyectado		8/4/98	
Comprobado			
Escala			
Firma			 Fagor Industrial, Coop. Ek. I. Irujoa
HORNO HMI-10/11 INYECCION			Plano número HC-73224-02
No hacer cableado en la versión que aparece en el plano			Se sustituye al nº
			Se sustituye por

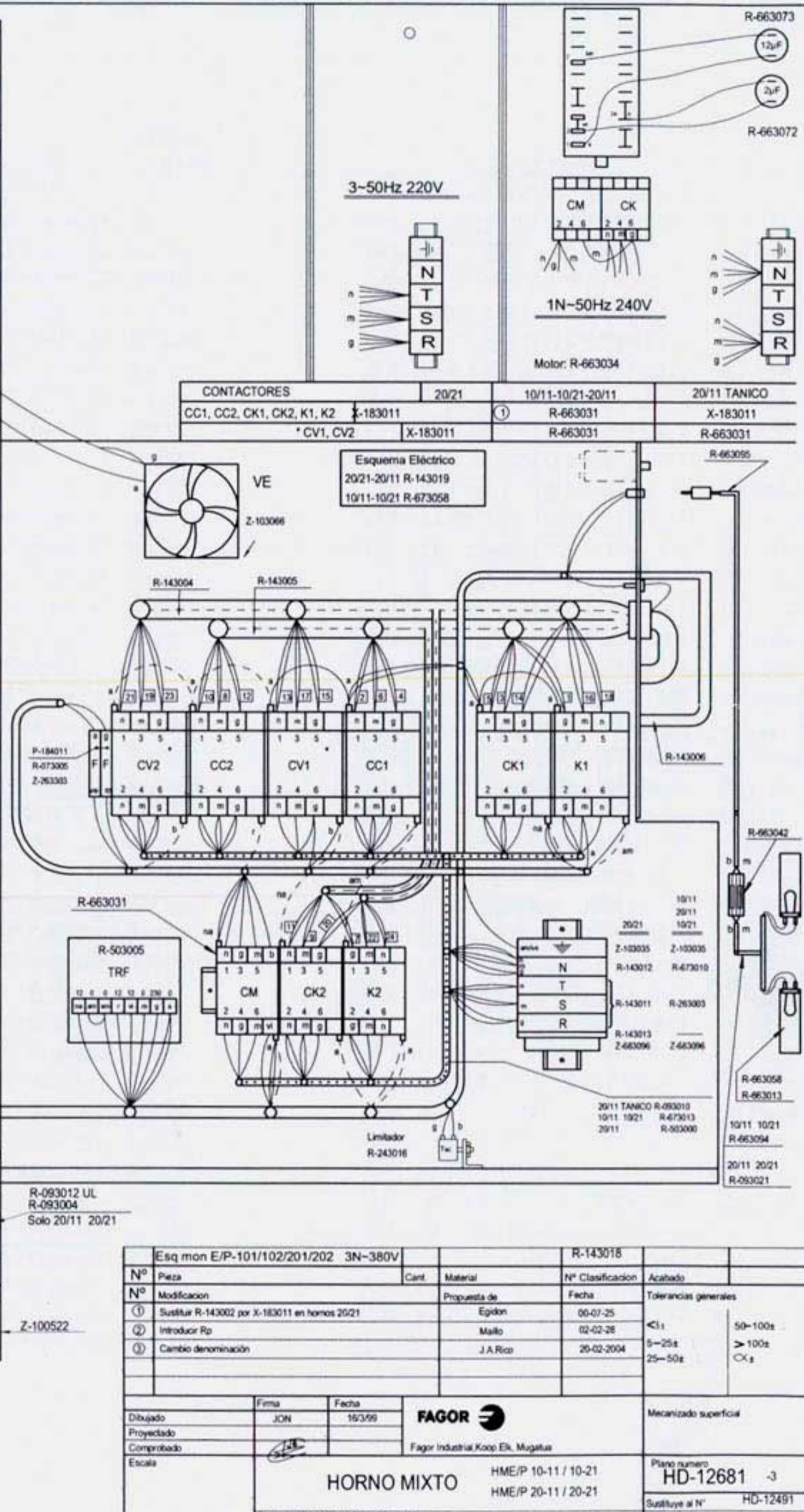
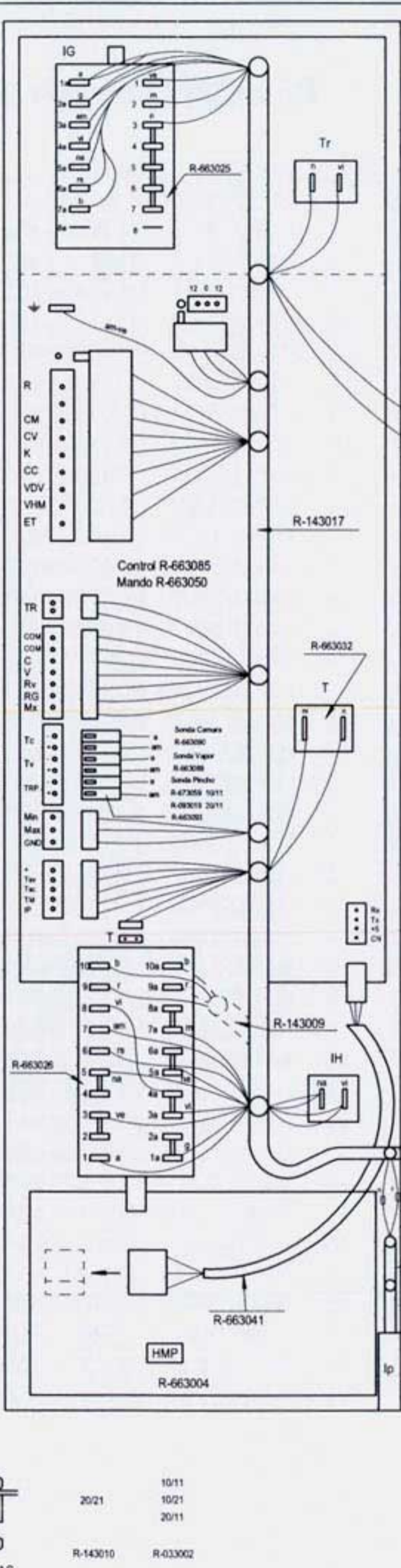
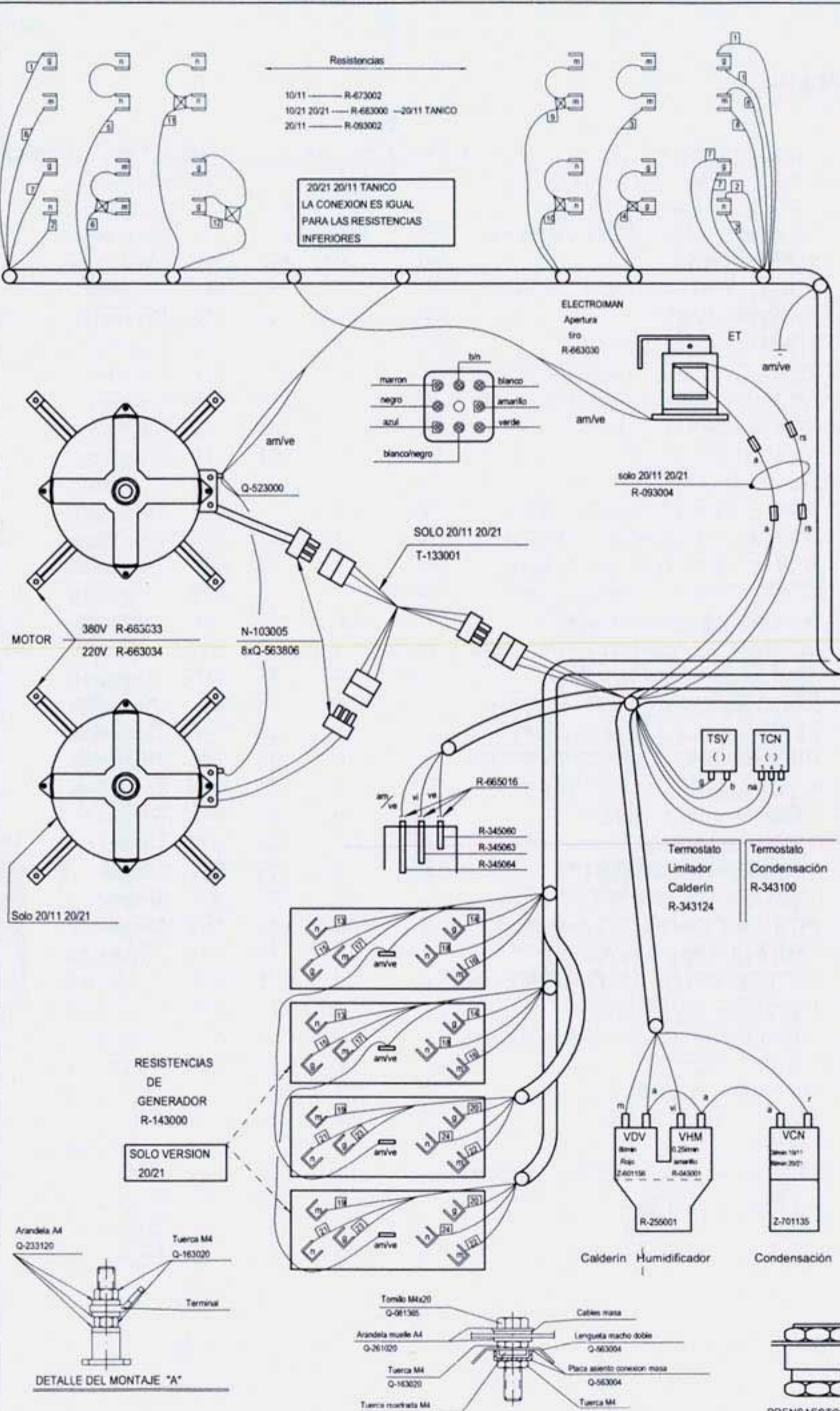

Esq mon E/P-101/102/201/202 3N-380V			R-143018		
Nº	Pieza	Cant.	Material	Nº Clasificación	Acabado
1	Sustituir R-143002 por X-183011 en hornos 20/21		Egidon	00-07-25	Tolerancias generales
2	Introducir Rp		Maillo	02-02-28	<1
3	Cambio denominación		J.A.Rico	26-02-2004	5-25e >100e >Xg

Dibujado	JON	Fecha	16/3/99
Proyectado			
Comprobado			
Escala			

FAGOR
 Fagor Industrial Koop Elk. Mugatu

HORNO MIXTO
 HME/P 10-11 / 10-21
 HME/P 20-11 / 20-21

Plano número **HD-12681 -3**
 Sustituye al N° **HD-12491**
 Sustituido por