

**Lavavajillas de capota  
Lave-vaisselle d' capot  
Pass-through dishwasher  
Durchschub geschirrspüler  
Lavastoviglie a cappuccio  
Lava-louças de capota**

**Modelos:**

**FI-100  
FI-100 B  
FI-100 AR  
FI-100B BT UK**

***Julio 2007 July***

***Revisado Septiembre 2013 September Revised***



---

F A G O R I N D U S T R I A L

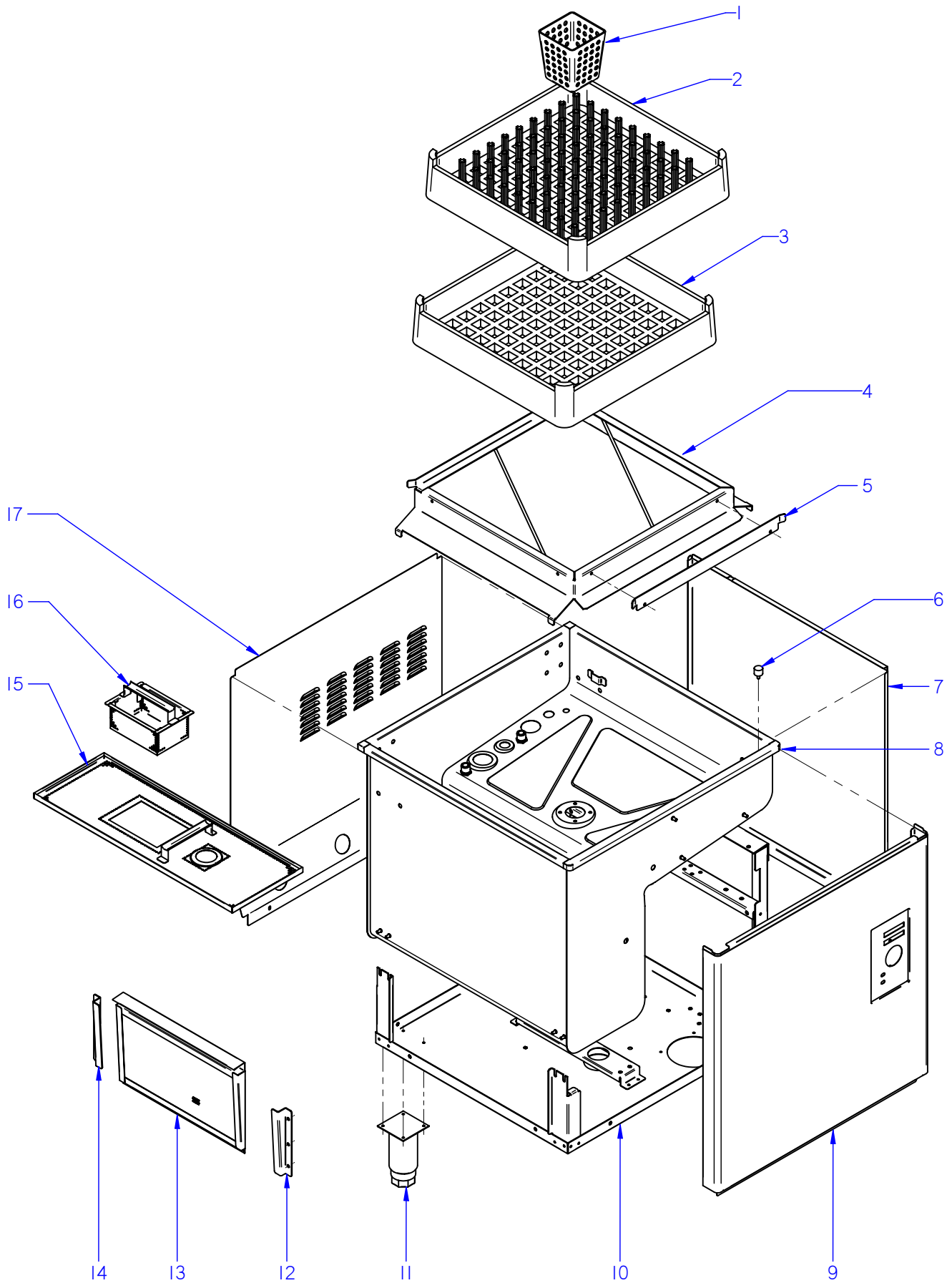

ITEM MARCADO EN COLOR = REPUESTO RECOMENDADO  
 COLOURED ITEM = RECOMMENDED SPARE PART

N plano	Firma	Fecha	Aparato	MUEBLE	Lamina	Fagor Industrial S.Coop. <b>FAGOR</b>
C-1880	<i>(Signature)</i>	2007-07	LAVAVAJILLAS FI-100		1	Oñate

MOD.		LAVAVAJILLAS DE CAPOTA		ZONA	MUEBLE				PLANO	C-1880
ITEM	CODIGO	DENOMINACION	TEXTO	FI-100	FI-100 B	FI-100 AR	FI-100B BT UK			NOTAS
1	Z655314000	CESTILLO CUBIERTOS	CUTLERY BASKET	8	8	8	8			
2	Z655302000	CESTILLO PLATOS CP-16-18	PLATE BASKET CP-16-18	1	1	1				
3	Z655301000	CESTILLO BASE CT-10	BASE BASKET CT-10	1	1	1	1			
4	Z710325000	BASE CESTILLO COMPLETA	COMPLETE BASKET BASE	1	1	1	1			ELIMINADO 26.09.01
4	Z710377000	BASE CESTILLO COMPLETA	COMPLETE BASKET BASE	1	1	1	1			INTRODUCIDO 26.09.01
5	Z710326000	GUIA CESTILLO	BASKET GUIDE	1	1	1	1			
	Q152004000	TORNILLO APLAST. M5x13 A304	MUSHROOM HEAD BOLT M5x13	2	2	2	2			
	Q242030000	ARANDELA ABANICO A5 A.304	FAN WASHER A5 A.304	2	2	2	2			
	Q162030000	TUERCA EXAGONAL M5	HEXAGONAL NUT M5	2	2	2	2			
	Q308000000	ARANDELA DUBO A.8	DUBO A.8 WASHER	14	14	14	14			
6	Z710316000	AMORTIGUADOR	DAMPER	2	2	2	2			
	Q262040000	ARANDELA GROW. A6 A.304	WASHER GROW. A6 A.304	2	2	2	2			
	Q162040000	TUERCA EXAGONAL M6	HEXAGONAL NUT M6	2	2	2	2			
	Q012073000	TORNILLO EXAGONAL M12x20	HEXAGONAL BOLT M12x20	1	1	1	1			
	Q306024000	JUNTA 18x12.2x1.5	SEAL 18x12.2x1.5	1	1	1	1			
	Q162070000	TUERCA EXAGONAL M12	HEXAGONAL NUT M12	1	1	1	1			
7	Z749311000	PANEL LATERAL DCHO	RIGHT SIDE PANEL	1	1	1	1			
S/Nº	Z749312000	PANEL LATERAL IZDO.	LEFT SIDE PANEL	1	1	1	1			
8	Z710301000	CUBA COMPLETA FI-100	COMPLETE TUB FI-100	1	1					ELIMINADO 20.06.08
8	Z710375000	CUBA COMPLETA FI-100	COMPLETE TUB FI-100	1	1					ELIMINADO 06.07.10
8	Z710381000	CUBA COMPLETA FI-100-120	COMPLETE TUB FI-100-120	1	1					INTRODUCIDO 06.07.10
8	Z718305000	CUBA COMPLETA FI-100 AR	COMPLETE TUB FI-100			1				ELIMINADO 20.06.08
8	Z718307000	CUBA COMPLETA FI-100 AR	COMPLETE TUB FI-100			1				ELIMINADO 06.07.10
8	Z718308000	CUBA COMPLETA FI-100-120 AR	COMPLETE TUB FI-100-120 AR			1				INTRODUCIDO 06.07.10
8	Z718914000	CUBA COMPLETA CLINIC	COMPLETE TUB CLINIC				1			ELIMINADO 20.06.08
8	Z718956000	CUBA COMPLETA CLINIC	COMPLETE TUB CLINIC				1			ELIMINADO 06.07.10
8	Z727401000	CUBA COMPLETA FI-120 CLINIC	COMPLETE TUB FI-120 CLINIC				1			INTRODUCIDO 06.07.10
	Q232040000	ARANDELA A6	WASHER A6	4	4	4	4			
	Q302022000	ARANDELA 16x6x1.2 A.304	WASHER 16X6X1.2 A.304	4	4	4	4			
	Q262040000	ARANDELA GROW. A6 A.304	WASHER GROW. A6 A.304	8	8	8	8			
	Q162040000	TUERCA EXAGONAL M6	HEXAGONAL NUT M6	8	8	8	8			

MOD.		LAVAVAJILLAS DE CAPOTA		ZONA		MUEBLE		PLANO		C-1880	
ITEM	CODIGO	DENOMINACION	TEXTO	FI-100	FI-100 B	FI-100 AR	FI-100B BT UK				NOTAS
9	Z712927000	PANEL FRONTAL FI-120	FRONT PANEL FI-80	1	1	1	1				ELIMINADO 29.01.2013
9	12048218	PANEL FRONTAL FI FAGOR COMP.	FRONT PANEL FI FAGOR COMP.	1	1	1	1				INTRODUCIDO 29.01.2013
S/Nº	Z206135000	CHECK LIST LAVAVAJILLAS FAGOR	CHECK LIST	1	1	1	1				INTRODUCIDO 19.07.10
10	Z749303000	ARMAZON COMPLETO	COMPLETE FRAME	1	1	1					
10	Z718921000	ARMAZON COMPLETO CLINIC	COMPLETE FRAME CLINIC				1				
11	X260151000	PATA REGULABLE	ADJUSTABLE LEG	4	4	4	4				
	Q411304000	REMACHE AVIBULB Ø 4,8	AVIBULB RIVET Ø4.8	16	16	16	16				
12	Z710309000	GUIA FILTRO ANTERIOR	FRONT FILTER GUIDE	1	1	1	1				
	Q232040000	ARANDELA A6	WASHER A6	2	2	2	2				
	Q162040000	TUERCA EXAGONAL M6	HEXAGONAL NUT M6	2	2	2	2				
13	Z710907000	FILTRO COMPLETO	COMPLETE FILTER	1	1	1	1				ELIMINADO 18.02.2013
13	12048626	FILTRO	FILTER	1	1	1	1				INTRODUCIDO 18.02.2013
14	Z710310000	GUIA FILTRO POSTERIOR	REAR FILTER GUIDE	1	1	1	1				
	Q232040000	ARANDELA A6	WASHER A6	2	2	2	2				
	Q162040000	TUERCA EXAGONAL M6	HEXAGONAL NUT M6	2	2	2	2				
15	Z710801000	BANDEJA COMPLETA	COMPLETE TRAY	1	1	1	1				
16	Z710804000	RECOGEDOR DESPERDICIOS	WASTE COLLECTION	1	1	1	1				
17	Z742905000	PANEL POSTERIOR FI-80	REAR PANEL FI-80	1	1	1	1				
	3713500000	PERFIL CUBREARISTAS PLASTICO	PLASTIC EDGE COVER PROFILE	3	3	3	3				
	Q152004000	TORNIL, APLASTADO M5x13 A304	FLAT HEADED BOLT M5x13 A304	2	2	2	2				
	Z712911000	TOPE 80x80x20	BUFFER 80x80x20	6	6	6	6				

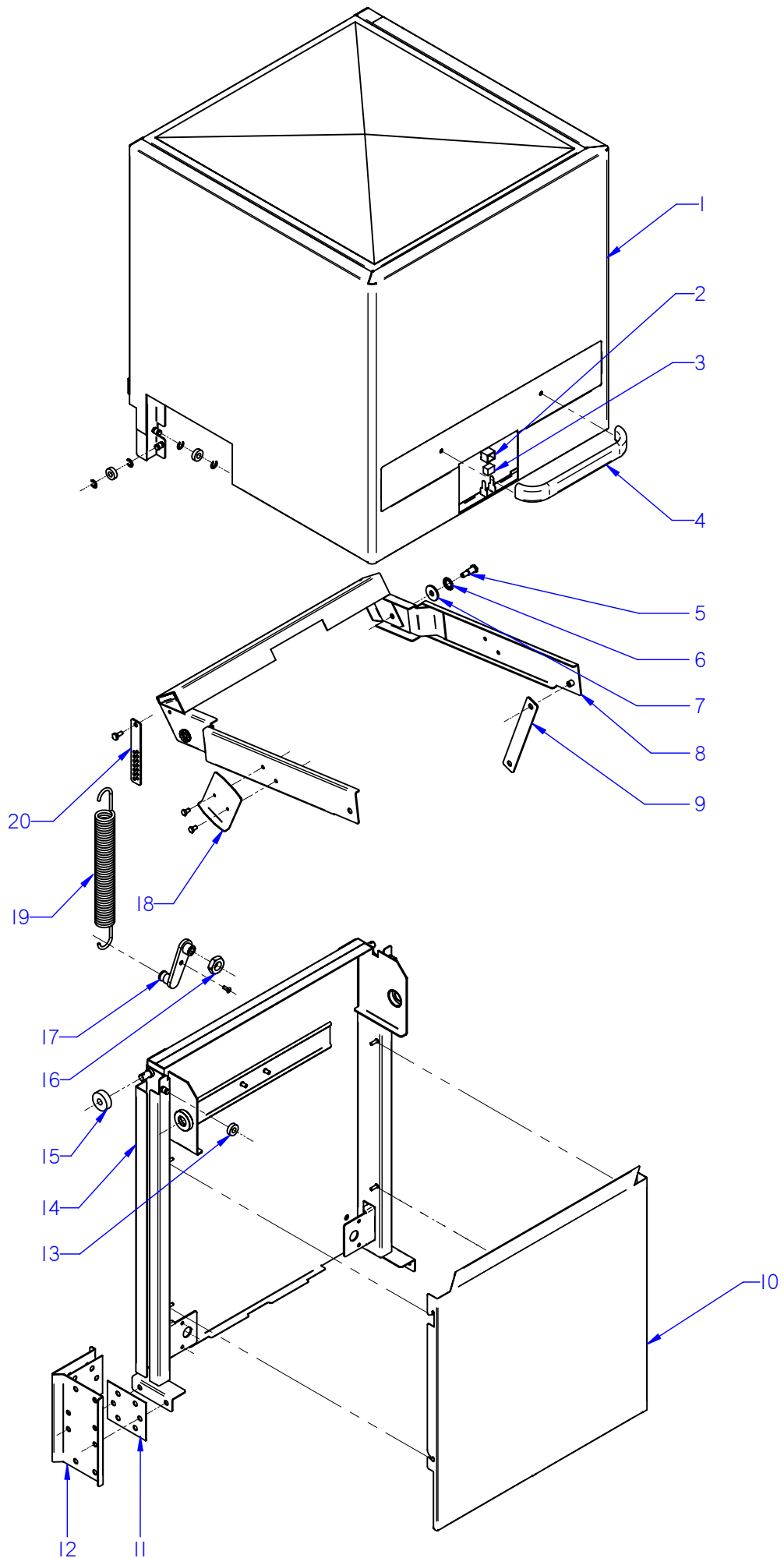

ITEM MARCADO EN COLOR = REPUESTO RECOMENDADO  
 COLOURED ITEM = RECOMMENDED SPARE PART

N plano	Firma	Fecha	Aparato	CAPO	Lamina	Fagor Industrial S.Coop. <b>FAGOR</b>
C-1881	<i>(Signature)</i>	2007-07	LAVAVAJILLAS FI-100		2	Oñate

MOD.		LAVAVAJILLAS DE CAPOTA		ZONA	CAPO				PLANO	C-1881
ITEM	CODIGO	DENOMINACION	TEXTO	FI-100	FI-100 B	FI-100 AR	FI-100B BT UK			NOTAS
1	Z710580000	CAPO COMPLETO	COMPLETE STRAIGHT HOOD	1	1	1	1			ELIMINADO 20.04,09
1	Z710557000	CAPO COMPLETO	COMPLETE STRAIGHT HOOD	1	1	1	1			INTRODUCIDO 20.04,09
	Z710515000	CASQUILLO RODANTE	REVOLVING BUSHING	4	4	4	4			
	Q271006000	ARANDELA DE SEGURIDAD 8	SAFETY WASHER 8	8	8	8	8			
2	Z200507000	PROTECTOR IMAN	MAGNET PROTECTOR	1	1	1	1			
3	Z200506000	IMAN	MAGNET	1	1	1	1			
4	Z400542000	ASA LVS.	AD HOOD HANDLE	1	1	1	1			
	Q032041000	TORNILLO ALOMADO M6x10	CURVED SCREW M6x10	2	2	2	2			
	Q308002000	ARANDELA DUBO A6 NYLON	WASHER DUBO A6 NYLON	2	2	2	2			
5	Z710542000	EJE DE GIRO	ROTARY SHAFT	2	2	2	2			
6	Z710541000	RODAMIENTO 6200-2RS1	BEARING 6200-2RS1	2	2	2	2			
7	Q308012000	ARANDELA 30x10x3	WASHER 30x10x3	2	2	2	2			
8	Z710517000	BALANCIN COMPLETO	COMPLETE ROCKER ARM	1	1	1	1			
	Q232050000	ARANDELA A8	WASHER A8	2	2	2	2			
	Q262050000	ARANDELA GROW. A8 A.304	WASHER GROW. A8 A.304	2	2	2	2			
	Q162050000	TUERCA EXAGONAL M8x1 INOX.	HEXAGONAL NUT M8x1 INOX.	2	2	2	2			
9	Z710523000	BIELA	ROD	2	2	2	2			
	Q308012000	ARANDELA 30x10x3	WASHER 30x10x3	8	8	8	8			
	Q232040000	ARANDELA A6	WASHER A6	4	4	4	4			
	Q262040000	ARANDELA GROW. A6 A.304	WASHER GROW. A6 A.304	4	4	4	4			
	Q012041000	TORNILLO EXAGON. M6x10 A.304	HEXAGONAL BOLT. M6x10 A.304	4	4	4	4			
10	Z718932000	CUBIERTA RESORTES	SPRING COVER	1	1	1	1			
11	Z710547000	JUNTA SOPORTE CAPO	HOOD SUPPORT SEAL	4	4	4	4			
	Q012053000	TORNILLO EXAGON. M8x20 A.304	HEXAGONAL BOLT. M8x20 A.304	10	10	10	10			
	Q013153000	TORNILLO EX M-8x20 LATON CRO.	HEX BOLT M-8x20 CHR. BRASS	4	4	4	4			
	Q232050000	ARANDELA A8	WASHER A8	14	14	14	14			
	Q262050000	ARANDELA GROW. A8 A.304	WASHER GROW. A8 A.304	14	14	14	14			
	Q162050000	TUERCA EXAG. M8x1 INOX.	HEXAG. SCREW M8x1 STAINLES	10	10	10	10			
12	Z710539000	SOPORTE GUIA CAPO	HOOD GUIDE SUPPORT	2	2	2	2			
13	Z710515000	CASQUILLO RODANTE	REVOLVING BUSHING	2	2	2	2			
	Q271006000	ARANDELA DE SEGURIDAD 8	SAFETY WASHER 8	4	4	4	4			



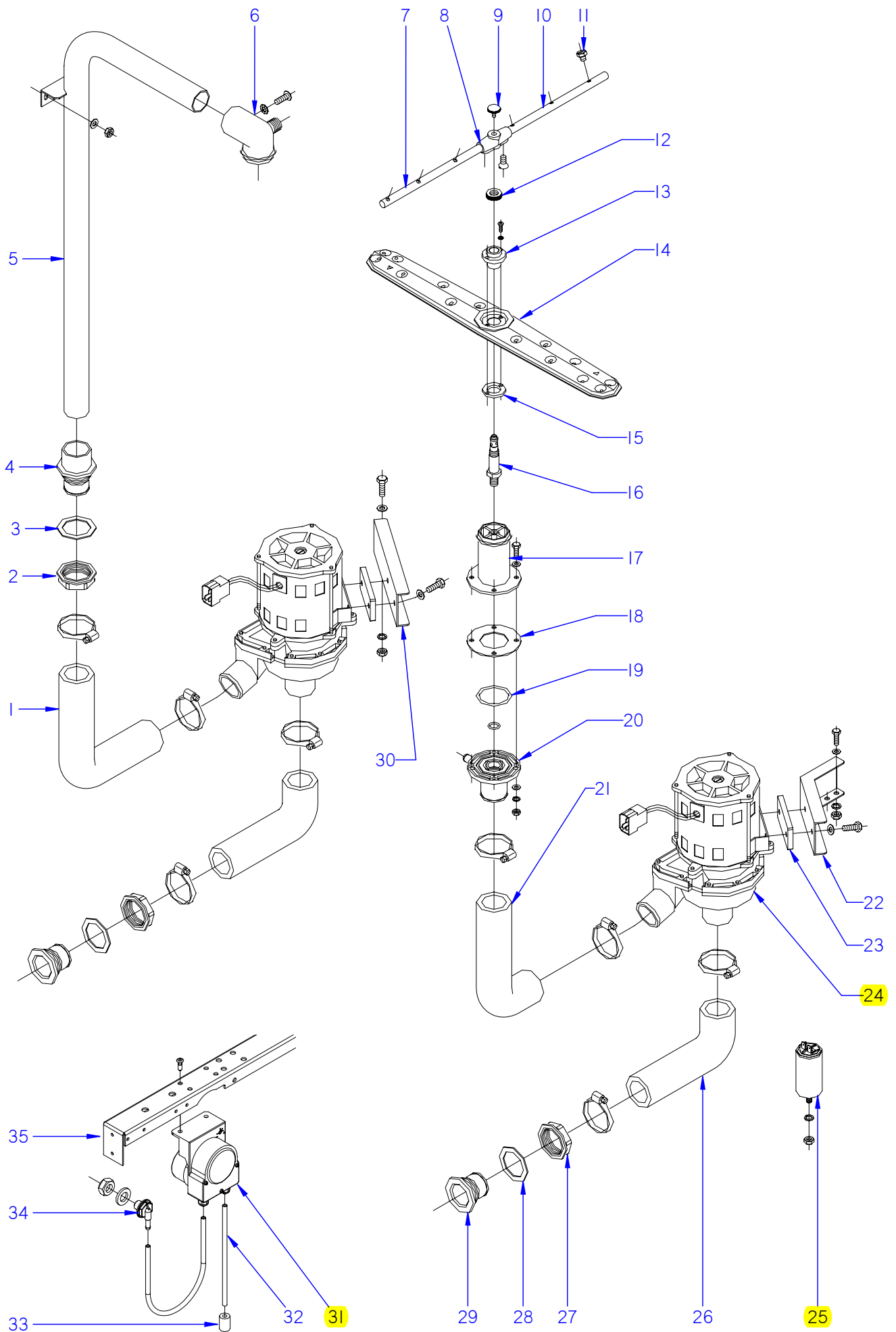

ITEM MARCADO EN COLOR = REPUESTO RECOMENDADO  
 COLOURED ITEM = RECOMMENDED SPARE PART

N plano	Firma	Fecha	Aparato	PARTE FUNCIONAL LAVADO	Lamina	Fagor Industrial S.Coop. <b>FAGOR</b>
C-1882	<i>[Signature]</i>	2007-07	LAVAVAJILLAS FI-100		3	Oñate



MOD.		LAVAVAJILLAS DE CAPOTA		ZONA	PARTE FUNCIONAL DE LAVADO				PLANO	C-1882
ITEM	CODIGO	DENOMINACION	TEXTO	FI-100	FI-100 B	FI-100 A.R+DD	FI-100B BT UK			NOTAS
1	Z710906000	CONDUCTO IMPULSION POSTER.	REAR IMPULSE PIPE	1	1	1	1			
	Q881307000	ABRAZADERA 40-60	CLAMP 40-60	2	2	2	2			
2	Z710708000	TUERCA PASAMUROS	WALL BUSHING NUT	1	1	1	1			
3	Q307058000	ARANDELA 60x44x2	WASHER 60x44x2	1	1	1	1			
4	Z740701000	PASAMUROS ARBOL LAVADO	WASH CAM BUSHING	1	1	1	1			
5	Z710709000	ARBOL LAVADO COMPLETO	COMPLETE WASH CAM	1	1	1	1			
	Q232040000	ARANDELA A6	WASHER A6	2	2	2	2			
	Q162040000	TUERCA EXAGONAL M6	HEXAGONAL NUT M6	2	2	2	2			
6	Z710705000	SOPORTE DISTRIBUIDOR SUPER.	UPPER DISTRIBUTION SUPPORT	1	1	1	1			
	Q152004000	TORNILLO APLAST. M5x13 A.304	MUSHROOM HEAD BOLT M5x13	1	1	1	1			
	Q242030000	ARANDELA ABANICO A5 A.304	FAN WASHER A5 A.304	1	1	1	1			
7	Z201902000	RAMA ACLARADO IZQUIERDA	LEFT RINSE BRANCH	2	2	2	2			
8	Z201903000	SOPORTE RAMA ACLARADO COM.	COM. RINSE BRANCH SUPPORT	2	2	2	2			
	Q042021000	TORNILLO AVELLAN. M4x10 A304	COUNTERSUNK BOLT M4x10 A304	4	4	4	4			
9	Q152016000	TORNILLO ESPECIAL M.5x0.8	SPECIAL BOLT M.5X0.8	2	2	2	2			
10	Z201901000	RAMA ACLARADO DERECHA	RIGHT RINSE BRANCH	2	2	2	2			
11	Z211903000	TOBERA ACLARADO	RINSE NOZZLE	12	12	12	12			
12	Z680738000	TUERCA ESPECIAL	SPECIAL NUT	2	2	2	2			
13	Z710712000	CASQUILLO DISTRIBUIDOR	DISTRIBUTOR BUSHING	2	2	2	2			
	Q032011000	TORNILLO ALOMADO M3x10	CURVED SCREW M3X10	4	4	4	4			
	Q242010000	ARANDELA ABANICO A3 A.304	FAN WASHER A3 A.304	4	4	4	4			
14	Z710701000	DISTRIBUIDOR COMPLETO	COMPLETE DISTRIBUTOR	2	2	2	2			
15	Z710713000	ARANDELA AMARRE	ANCHORAGE WASHER	2	2	2	2			
16	Z710711000	EJE CENTRAL	CENTRAL SHAFT	2	2	2	2			
17	Z710719000	SOPORTE DISTRIBUIDOR INFERIOR	LOWER DISTRIBUTION SUPPORT	1	1	1	1			
18	Z710714000	JUNTA DE GOMA	RUBBER SEAL	1	1	1	1			
19	Q307057000	JUNTA TORICA 47.22x54.28x3.53	O-RING 47.22x54.28x3.53	1	1	1	1			
	Q307050000	JUNTA TORICA 13.94x19.18x2.6	O-RING 13.94x19.18x2.6	1	1	1	1			

MOD.		LAVAVAJILLAS DE CAPOTA		ZONA	PARTE FUNCIONAL DE LAVADO				PLANO	C-1882
ITEM	CODIGO	DENOMINACION	TEXTO	FI-100	FI-100 B	FI-100 A.R+DD	FI-100B BT UK			NOTAS
20	Z710706000	PASAMUROS	BUSHING	1	1	1	1			
	Q012044000	TORNILLO EXAGONAL M6x25	HEXAGONAL BOLT M6x25	4	4	4	4			
	Q306050000	ARANDELA 6x12x1.5	WASHER 6x12x1.5	4	4	4	4			
	Q232040000	ARANDELA A6	WASHER A6	4	4	4	4			
	Q262040000	ARANDELA GROW. A6 A.304	WASHER GROW. A6 A.304	4	4	4	4			
	Q162040000	TUERCA EXAGONAL M6	HEXAGONAL NUT M6	4	4	4	4			
21	Z710905000	CONDUCTO IMPULSION ANTER.	FRONT IMPULSE PIPE	1	1	1	1			
	Q881307000	ABRAZADERA 40-60	CLAMP 40-60	2	2	2	2			
22	Z711001000	SOPOR. MOTOBOMBA ANTERIOR	SUPPORT FRONT MOTOR-PUMP	1	1	1	1			
	Q012042000	TORNILLO EXAGONAL M6x15	HEXAGONAL BOLT M6x15	2	2	2	2			
	Q232040000	ARANDELA A6	WASHER A6	2	2	2	2			
	Q262040000	ARANDELA GROW. A6 A.304	WASHER GROW. A6 A.304	2	2	2	2			
	Q162040000	TUERCA EXAGONAL M6	HEXAGONAL NUT M6	2	2	2	2			
23	Z201003000	BASE BOMBA LAVADO 1003016	WASH PUMP BASE 1003016	2	2	2	2			
	Q232040000	ARANDELA A6	WASHER A6	4	4	4	4			
	Q012042000	TORNILLO EXAGONAL M6x15	HEXAGONAL BOLT M6x15	4	4	4	4			
24	Z201011000	BOMBA DE LAVADO	WASH PUMP	2	2	2	2			
	Z201082000	TURBINA PARA 50 HZ.88 MM	TURBINE 50 HZ.88 MM	2	2	2	2			
	Z201081000	CONJUNTO JUNTA Y RETEN	JOINT BOARD AND SEAL	2	2	2	2			
24	Z203511000	BOMBA DE LAVADO 60 HZ.	WASH PUMP 60 Hz.	2	2	2	2			
	Z201083000	TURBINA 60 HZ.78 MM	TURBINE 60 HZ.78 MM	2	2	2	2			
	Z201081000	CONJUNTO JUNTA Y RETEN	JOINT BOARD AND SEAL	2	2	2	2			
25	V321300000	CONDENSADOR 10 M,F,	CONDENSER 10 M,F,	2	2	2	2			
	Q162050000	TUERCA EXAGONAL M8x1 INOX,	HEXAGONAL NUT M8x1 INOX.	2	2	2	2			
26	Z710904000	CONDUCTO ASPIRACION	EXTRACTOR PIPE	2	2	2	2			
	Q881307000	ABRAZADERA 40-60	CLAMP 40-60	4	4	4	4			
27	Z710708000	TUERCA PASAMUROS	WALL BUSHING NUT	2	2	2	2			
28	Q307058000	ARANDELA 60x44x2	WASHER 60x44x2	2	2	2	2			
29	Z710903000	PASAMUROS ASPIRACION	EXTRACTOR BUSHING	2	2	2	2			
30	Z711002000	SOPORTE MOTOBOMBA POSTER.	REAR MOTOR PUMP SUPPORT	1	1	1	1			
	Q012042000	TORNILLO EXAGONAL M6x15	HEXAGONAL BOLT M6x15	2	2	2	2			



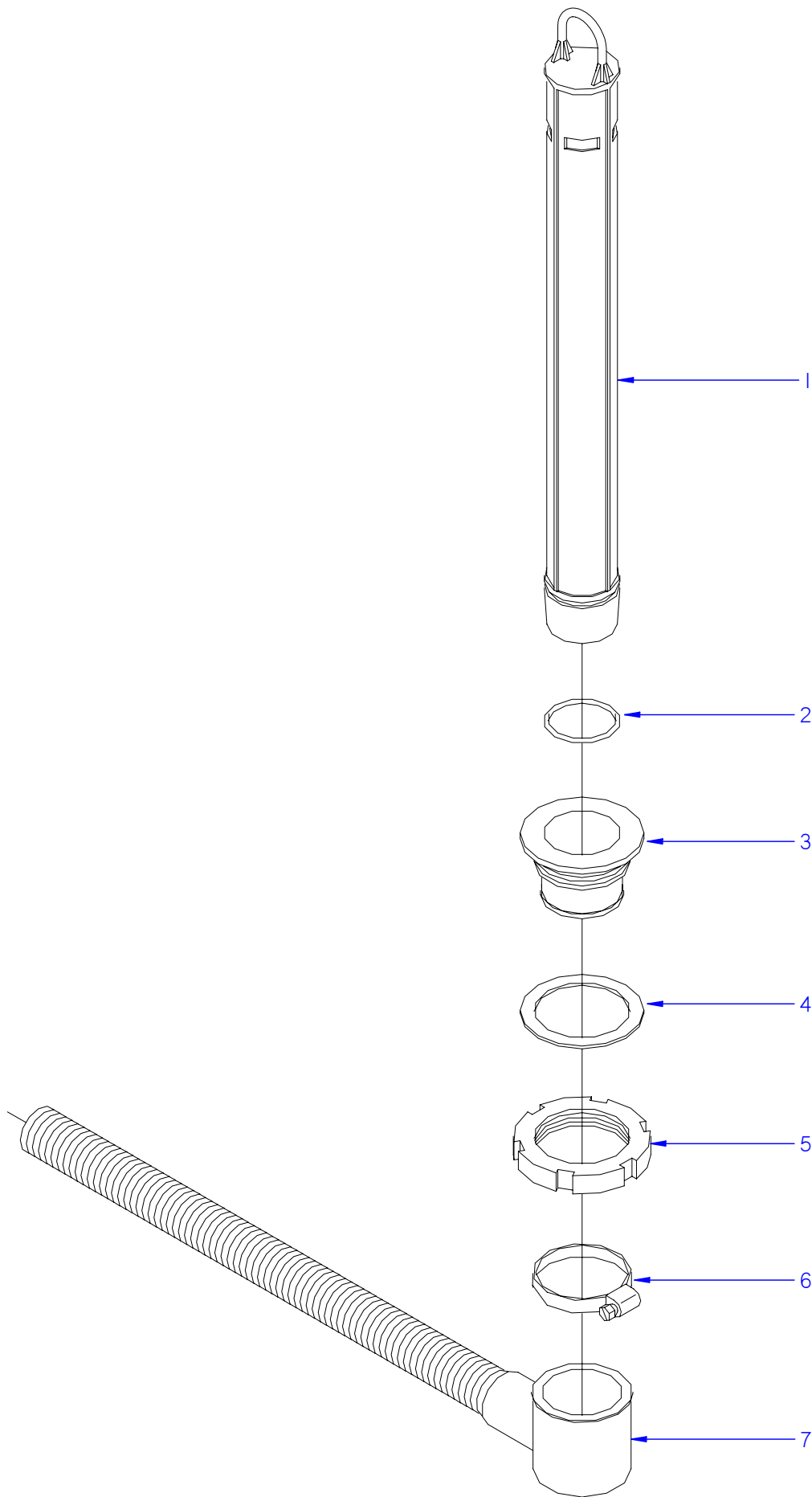

ITEM MARCADO EN COLOR = REPUESTO RECOMENDADO  
 COLOURED ITEM = RECOMMENDED SPARE PART

N plano	Firma	Fecha	Aparato	PARTE FUNCIONAL DESAGUE	Lamina	Fagor Industrial S.Coop. <b>FAGOR</b>
C-1883	<i>[Signature]</i>	2007-07	LAVAVAJILLAS FI-100		4	Oñate



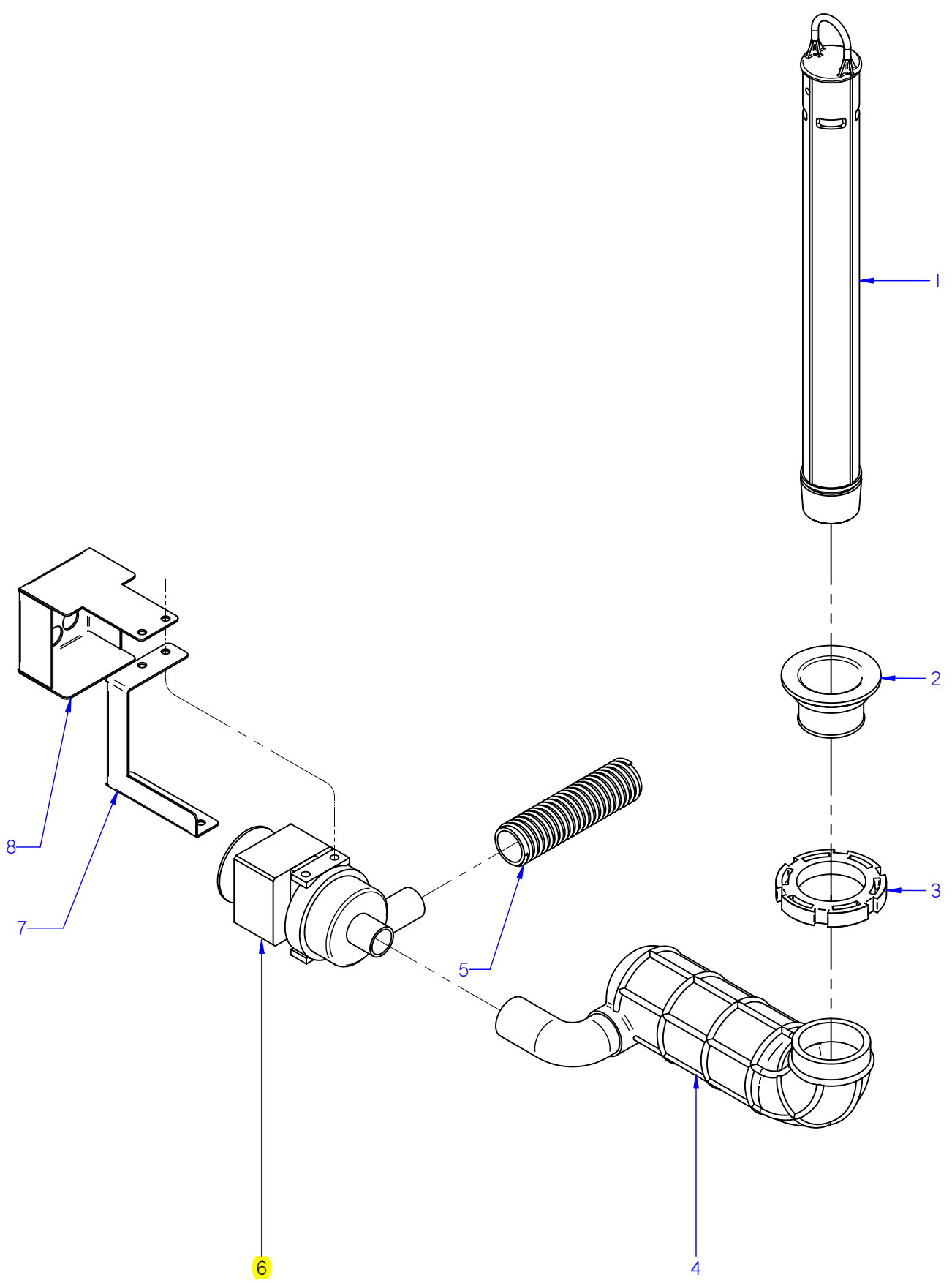

ITEM MARCADO EN COLOR = REPUESTO RECOMENDADO  
 COLOURED ITEM = RECOMMENDED SPARE PART

N plano	Firma	Fecha	Aparato	PARTE FUNCIONAL DESAGUE	Lamina	Fagor Industrial S.Coop. <b>FAGOR</b>
C-1884	<i>(Signature)</i>	2007-07	LAVAVAJIL. FI-100B BT UK; FI-100B		5	Oñate

<b>ITEM</b>	<b>CODIGO</b>	<b>DENOMINACION</b>	<b>TEXTO</b>	<b>FI-100 B</b>	<b>FI-100B BT UK</b>							<b>NOTAS</b>
1	Z710901000	ALIVIADERO	OVERFLOW	1	1							
	Q307051000	JUNTA TORICA 36.17x41.41x2.6	O-RING 36.17x41.41x2.6	1	1							
2	Z710902000	PASAMUROS DESAGUE	DRAINAGE BUSHING	1	1							
	Q307059000	ARANDELA 72x56x2	WASHER 72x56x2	1	1							
3	Q220001000	TUERCA RANURADA	GROOVED NUT	1	1							
4	Z711004000	ACUMULADOR CAPOTA	HOOD ACCUMULATOR	1	1							
	Q881304000	ABRAZADERA 20-32	CLAMP 20-32	2	2							
5	Z220903000	MANGUERA DESAGUE	DRAINAGE HOSE	1	1							
	Q881307000	ABRAZADERA 40-60	CLAMP 40-60	1	1							
6	Z711007000	BOMBA DESAGUE	DRAINAGE PUMP	1	1							
	Q262040000	ARANDELA GROW. A6 A.304	WASHER GROW. A6 A.304	4	4							
	Q012042000	TORNILLO EXAGONAL M6x15	HEXAGONAL BOLT M6x15	4	4							
	Q032032000	TORNILLO ALOMADO M5x15	CURVED SCREW M5X15	2	2							
	Q242030000	ARANDELA ABANICO A5 A.304	FAN WASHER A5 A.304	2	2							
7	Z711005000	SOPORTE MOTOBOMBA	MOTOR PUMP SUPPORT	1	1							
8	Z711006000	PROTECCION BOMBA	PUMP PROTECTION	1	1							

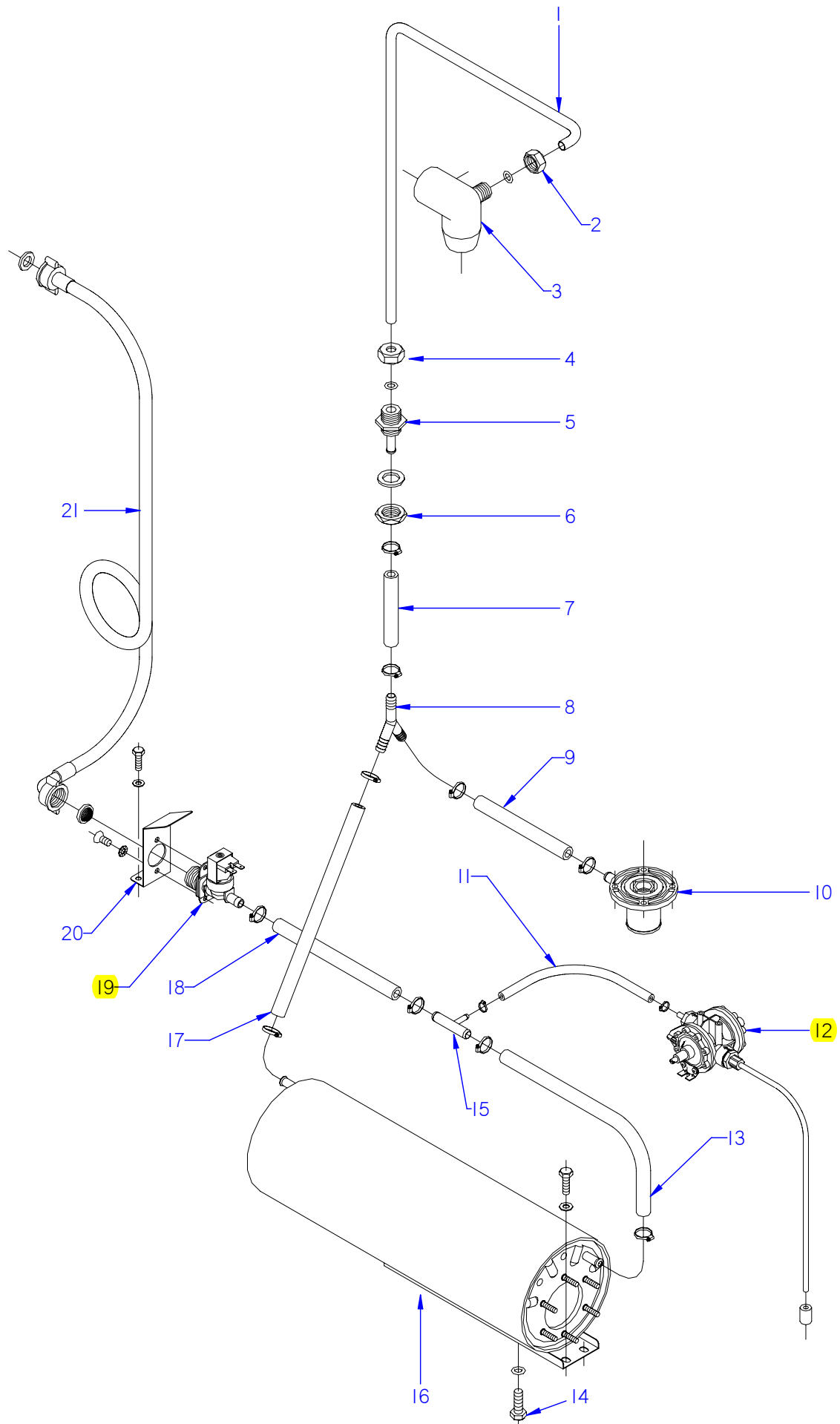

ITEM MARCADO EN COLOR = REPUESTO RECOMENDADO  
 COLOURED ITEM = RECOMMENDED SPARE PART

N plano	Firma	Fecha	Aparato	PARTE FUNCIONAL ACLARADO	bania	Fagor Industrial S.Coop. <b>FAGOR</b>
C-1885	<i>[Signature]</i>	2007-07	LAVAVAJILLAS FI-100		6	Oñate



MOD.		LAVAVAJILLAS DE CAPOTA		ZONA	PARTE FUNCIONAL ACLARADO					PLANO	C-1885
ITEM	CODIGO	DENOMINACION	TEXTO	FI-100	FI-100 B						NOTAS
1	Z711903000	CONDUCCION ACLARADO COMP.	COMP. RINSE PIPE	1	1						
2	Q223107000	TUERCA M.20x2.5	NUT M.20X2.5	1	1						
	Q307048000	JUNTA TORICA Ø9.12X16.18X3.53	O-RING Ø9.12X16.18X3.53	1	1						
3	Z710705000	SOPORTE DISTRIBUIDOR SUPER.	UPPER DISTRIBUTION SUPPORT	1	1						
	Q152004000	TORNILLO APLAST. M5x13 A.304	MUSHROOM HEAD BOLT M5x13	1	1						
	Q242030000	ARANDELA ABANICO A5 A.304	FAN WASHER A5 A.304	1	1						
4	Q223107000	TUERCA M.20x2.5	NUT M.20X2.5	1	1						
	Q307048000	JUNTA TORICA Ø9.12X16.18X3.53	O-RING Ø9.12X16.18X3.53	1	1						
5	Z711904000	PASAMUROS ACLARADO	RINSE BUSHING	1	1						
	Q307032000	JUNTA Ø 32X21X3	SEAL Ø 32X21X3	1	1						
6	Q223023000	TUERCA EXAGONAL 5-8 LATON	HEX NUT 5-8 BRASS	1	1						
7	3676900000	TUBO GOMA NEGRA Ø 17*10	BLACK RUBBER PIPE 17*10	1	1						
	Q881302000	ABRAZADERA 12-20	CLAMP 12-20	2	2						
8	Z201106000	RACORD EN Y	Y-CONNECTION	1	1						
9	3676900000	TUBO GOMA NEGRA Ø 17*10	BLACK RUBBER PIPE 17*10	1	1						
	Q881302000	ABRAZADERA 12-20	CLAMP 12-20	2	2						
10	Z710706000	PASAMUROS	BUSHING	1	1						
	Q012044000	TORNILLO EXAGONAL M6x25	HEXAGONAL BOLT M6x25	4	4						
	Q306050000	ARANDELA 6x12x1.5	WASHER 6x12x1.5	4	4						
	Q232040000	ARANDELA A6	WASHER A6	4	4						
	Q262040000	ARANDELA GROW. A6 A.304	WASHER GROW. A6 A.304	4	4						
	Q162040000	TUERCA EXAGONAL M6	HEXAGONAL NUT M6	4	4						
11	3704000000	TUBO GOMA NEGRO D 10,5*5	BLACK RUBBER PIPE Ø 10.5*5	1	1						
	Q881308000	ABRAZADERA 8-14L	CLAMP 8-14L	2	2						
12	Z211109000	DOSIFICADOR TENSOACTIVO N-6	SURFACE ACT. DISP. N-6	1	1						ELIMINADO 18.06.2012
12	12045206	DOSIFICADOR_ABRILLANTADOR_A	RINSE AID DISPENSER	1	1						INTRODUCIDO 18.06.2012
S/Nº	Z448618000	CONDUCTO ABRILLANTADOR	RINSE AID PIPE	1	1						INTRODUCIDO 03.04.09
	Q232030000	ARANDELA A5	WASHER A5	2	2						
	Q012031000	TORNIL. EXAGONAL M5x10 A.304	HEXAGONAL BOLT M5X10 A.304	4	4						



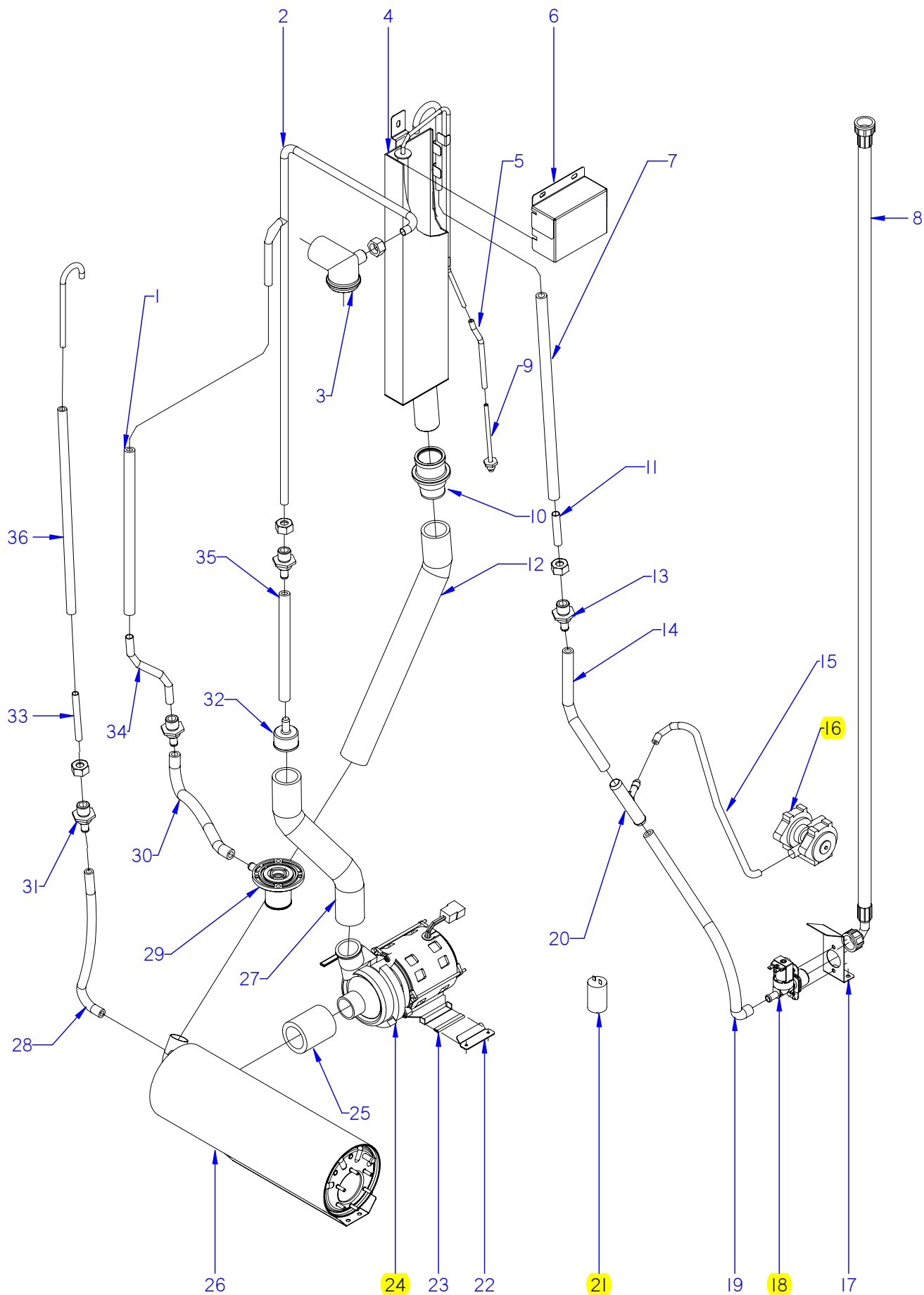

ITEM MARCADO EN COLOR = REPUESTO RECOMENDADO  
 COLOURED ITEM = RECOMMENDED SPARE PART

N plano	Firma	Fecha	Aparato	PARTE FUNCIONAL DE ACLARADO	Lamina	Fagor Industrial S.Coop. <b>FAGOR</b>
C-1886	<i>[Signature]</i>	2007-07	LAVAVAJILLAS FI-100B BT UK		7	Oñate

MOD.		LAVAVAJILLAS DE CAPOTA		ZONA	PARTE FUNCIONAL DE ACLARADO				PLANO	C-1886
ITEM	CODIGO	DENOMINACION	TEXTO	FI-100B BT UK						NOTAS
1	3676900000	TUBO GOMA NEGRA Ø 17*10	BLACK RUBBER PIPE 17*10	1						
	Q881302000	ABRAZADERA 12-20	CLAMP 12-20	2						
2	Z718911000	RAMA DE ACLARADO CLINIC	CLINIC RINSE BRANCH	1						
3	Z710705000	SOPORTE DISTRIBUIDOR SUPER.	UPPER DISTRIBUTION SUPPORT	1						
4	Z718909000	DEPOSITO CLINIC COMPLETO	CLINIC COMPLETE TANK	1						
4a	12008220	CAÑO	PIPE	1						INTRODUCIDO 29.01.2013
5	3702400000	TUBO DE GOMA Ø 8*4 x140	BLACK RUBBER PIPE Ø 8*4	1						
	P102154000	BRIDA ELASTICA TUBO	ELASTIC PIPE FLANGE	2						
6	Z718915000	TAPA DEPOSITO CLINIC	TANK COVER	1						
	Q162040000	TUERCA EXAGONAL M6	HEXAGONAL NUT M6	3						
7	3676900000	TUBO GOMA NEGRA Ø 17*10	BLACK RUBBER PIPE 17*10	1						
	Q881302000	ABRAZADERA 12*20	CLAMP 12-20	2						
8	Z602121000	MANGUERA ENTRADA DE AGUA	WATER INTAKE HOSE	1						
9	Z718918000	PASAMUROS PRES. CLINIC	PRES. CLINIC BUSHING	1						
10	Z330751000	PASAMUROS IMPULSION PRELAV.	IMPULSE PRELAV BUSHING	1						ELIMINADO 31.03.09
10	Z330790000	PASAMUROS IMPULSION PRELAV.	IMPULSE PRELAV BUSHING	1						INTRODUCIDO 31.03.09
	Q306024000	JUNTA 18x12.5x1.5	SEAL 18x12.5x1.5	1						
10	Z330751000	PASAMUROS IMPULSION PRELAV.		1						
	Q307065000	JUNTA TORICA 43,01x37,77x2,62	O-RING 43,01x37,77x2,62	1						
	Z710708000	TUERCA PASAMUROS	BUSHING NUT	1						
	Q307058000	ARANDELA 60x44x2	WASHER 60x44x2	1						
	Q881307000	ABRAZADERA 40*60	CLAMP 40*60	1						
11	Z718910000	TUBO ENTRADA AGUA	WATER INTAKE PIPE	1						
	Q307048000	JUNTA TORICA 9.12x16.18x3.53	O-RING Ø9.12X16.18X3.53	4						
12	Z718925000	CONDUCTO DEPOSITO-CALDERIN	DUCT-CALDERIN DEPOSIT	1						
	Q881307000	ABRAZADERA 40*60	CLAMP 40*60	2						
13	Z711904000	PASAMUROS ACLARADO	RINSE BUSHING	2						
	Q307032000	JUNTA 32x21x3	SEAL Ø 32X21X3	2						
	Q223023000	TUERCA EXAGONAL 5-8 LATON	HEX NUT 5-8 BRASS	2						
14	3676900000	TUBO GOMA NEGRA 17*10	BLACK RUBBER PIPE 17*10	1						
	Q881302000	ABRAZADERA 12*20	CLAMP 12-20	4						

MOD.		LAVAVAJILLAS DE CAPOTA		ZONA	PARTE FUNCIONAL DE ACLARADO				PLANO	C-1886
ITEM	CODIGO	DENOMINACION	TEXTO	FI-100B BT UK					NOTAS	
15	3704000000	TUBO GOMA NEGRA Ø10,5*5	BLACK RUBBER PIPE Ø10,5*5	1						
	Q881308000	ABRAZADERA 8-14L	CLAMP 8-14L	2						
16	Z651123000	DOSIFICADOR TENSOACTIVO N-6	SURFACE ACT. DISP. N-6	1					ELIMINADO 03.04.09	
17	Z201101000	ESCUADRA AMARRE ELECTROVA	SOLENOID VALVE BRACKET	1						
	Q152024000	TORNILLO AVELLAN. M4x8 A304	COUNTERSUNK NUT M4x8 A304	2						
	Q242020000	ARANDELA ABANICO A.4 A304	FAN WASHER A4 A.304	2						
	Q012031000	TORNILLO EXAGONAL. M5x10 A304	HEXAGONAL BOLT M5X10 A.304	2						
	Q232030000	ARANDELA A5	WASHER A5	2						
18	Z701135000	E.V. SIMPLE 0V COD. 255.208	SOLENOID VALVE SIMP. 0V COD.	1						
	Z841107000	REGUL.ENTRADA 10L 254.067	REGULATOR 10L 254.067	1					ELIMINADO 01.05.12	
	12044690	REGULADOR DE CAUDAL 10L	FLOW REGULATOR 10L	1					INTRODUCIDO 01.05.12	
19	3676900000	TUBO GOMA NEGRA 17*10	BLACK RUBBER PIPE Ø 17*10	1						
	Q881302000	ABRAZADERA 12*20	CLAMP 12-20	4						
20	Z601157000	TOMA PRESION	PRESSURE INTAKE	1					ELIMINADO 01.04.08	
20	Z718949000	TE COMP. TOMA PRESION ABR	PRESSURE INTAKE TE ABR	1					INTRODUCIDO 01.04.08	
21	V817100000	CONDENSADOR 6 M,F,	CONDENSER 6 M,F,	1						
	Q162050000	TUERCA EXAGONAL M8x1 INOX,	HEXAGONAL NUT M6	1						
22	Z718931000	SOPORTE MOTOBOMBA CLINIC	CLINIC M-PUMP SUPPORT	1						
	Q152024000	TORNILLO AVELLAN. M4x8 A304	COUNTERSUNK NUT M4x8 A304	2						
23	3701700000	PERFIL GOMA NEGRO EN U 9*4	BLACK RUBBER PROFILE U 9*4	2						
24	Z401001000	BOMBA LAVADO	WASH PUMP	1						
	Z401001100	TURBINA BOMBA Z401001	TURBINE PUMP Z401001	1						
25	Z162301000	CONDUCTO ASPIRAC. IMPULSION	EXTRACTOR PIPE - IMPULSE	1						
	Q881307000	ABRAZADERA 40*60	CLAMP 40*60	2						
26	Z258916000	CALDERIN COMPLETO BBT.	COMPLETE DRUM BBT	1						
27	Z718935000	CONDUCTO IMPULSION CLINIC	CLINIC IMPULSE PIPE	1						
	Q881307000	ABRAZADERA 40*60	CLAMP 40*60	2						
28	3676900000	TUBO GOMA NEGRA 17*10	BLACK RUBBER PIPE Ø 17*10	1						
	Q881302000	ABRAZADERA 12*20	CLAMP 12-20	2						
29	Z710706000	PASAMUROS	BUSHING	1						



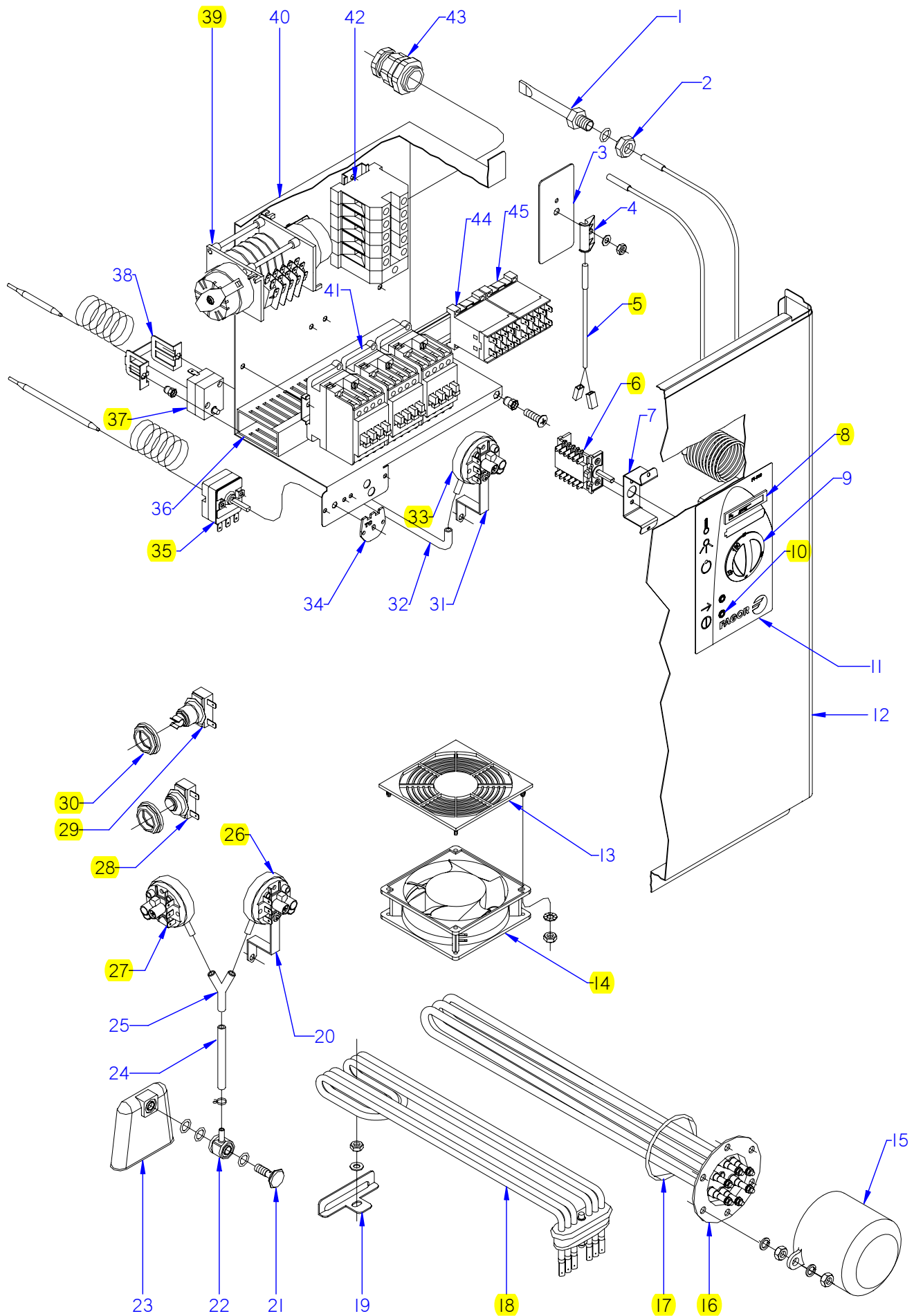

ITEM MARCADO EN COLOR = REPUESTO RECOMENDADO  
 COLOURED ITEM = RECOMMENDED SPARE PART

N plano	Firma	Fecha	Aparato	PARTE FUNCIONAL ELECTRICA	Lamina	Fagor Industrial S.Coop. <b>FAGOR</b>
C-1887	<i>[Signature]</i>	2007-07	LAVAVAJILLAS FI-100		8	Oñate

MOD.		LAVAVAJILLAS DE CAPOTA		ZONA	PARTE FUNCIONAL ELECTRICA			PLANO	C-1887	
ITEM	CODIGO	DENOMINACION	TEXTO	FI-100	FI-100 B	FI-100B BT UK				NOTAS
1	Z263002000	VAINA INDICADOR COMPLETA	COMPLETE INDICATOR SHELL	1	1	1				
	Q307048000	JUNTA TORICA Ø16,18xØ9,12xØ3,53	O-RING 18x12.5x1.5	1	1	1				
2	Q162070000	TUERCA EXAGONAL M-12	HEXAGONAL NUT M12	1	1	1				
3	Z101211000	APOYO INTERRUPTOR	SWITCH SUPPORT	1	1	1				
4	Z203010000	AMARRE INTERRUPTOR MAGNET.	MAGNETIC SWITCH FASTENER	1	1	1				
	Q232040000	ARANDELA A-6	WASHER A-6	1	1	1				
	Q162040000	TUERCA EXAGONAL M-6	HEXAGONAL NUT M-6	1	1	1				
5	Z203009000	INTERRUPTOR MAGNETICO	MAGNETIC SWITCH	1	1	1				
6	Z683085000	CONMUTADOR FUNCIONES	SWITCH	1						
6	Z713097000	CONMUTADOR	SWITCH		1	1				
	Q152024000	TORN. AVELLANADO M4x8 A.304	HEXAGONAL COUNTERSUNK M4	2	2	2				
7	Z712932000	SOPOR. CONMUTADOR CAPOTA	HOOD BRACKET SWITCH	1	1	1				
	Q419005000	REMACHE 4x8 ALMG3 / ALUMINIO	RIVET 4x8 ALMG3 / ALUMINIO	2	2	2				
8	Z203072000	INDICADOR ANALOGICO	ANALOG INDICATOR	2	2	2				
9	Z713091000	BOTON DE MANDO 100/120	CONTROL BUTTON 100/120	1						
9	Z713099000	BOTON DE MANDO B	CONTROL BUTTON B		1	1				
10	Z203079000	PILOTO AMBAR Ø10		2	2	2				
11	Z712916000	EMBELLECED. ADHESIVO FI-100	ADHESIVE TRIM FI-100	1						
11	Z712930000	EMBELLECED. ADHESIVO FI-100B	ADHESIVE TRIM FI-100B		1					
11	Z712934000	EMBELL. ADHESIVO FI-100B BT UK	ADHESIVE TRIM FI-100B BT UK			1				
12	Z712927000	PANEL FRONTAL FI-120	FRONT PANEL FI-80	1	1	1				ELIMINADO 29.01.2013
12	12048218	PANEL FRONTAL FI FAGOR COMP.	FRONT PANEL FI FAGOR COMP.	1	1	1				INTRODUCIDO 29.01.2013
13	Z713015000	PROTECCION VENTILADOR ABS	FAN PROTECTION	1	1	1				
	Q042022000	TORNILLO AVELLANADO M4x15	COUNTERSUNK BOLT M4x15	8	8	8				
	Q162020000	TUERCA EXAGONAL M4	HEXAGONAL NUT M4	12	12	12				
	Q242020000	ARANDELA ABANICO A-4 A304	FAN WASHER A-4 A304	8	8	8				
14	Z103066000	VENTILADOR 230V,50/60 HZ	FAN 230V,50/60 HZ	1	1	1				
15	Z651731000	CAPERUZA RESISTEN. CALDERIN	DRUM RESIST. CAP	1	1	1				
	Q163140000	TUERCA EXAGONAL M6 LATON	HEXAGONAL NUT M6 BRASS	2	2	2				
	Q012031000	TORNIL. EXAGONAL M5x10 A.304	HEXAGONAL BOLT M5X10 A.304	2	2	2				



MOD.		LAVAVAJILLAS DE CAPOTA		ZONA	PARTE FUNCIONAL ELECTRICA			PLANO	C-1887	
ITEM	CODIGO	DENOMINACION	TEXTO	FI-100	FI-100 B	FI-100B BT UK				NOTAS
16	Z721701000	RESISTENCIA CALDERIN	DRUM RESISTOR	1	1	1				
	Q221305000	TUERCA EX, AUTO. M4 ZINCADA	HEX NUT , AUTO. M4 ZINC-COAT	6	6	6				
	Q163140000	TUERCA EXAGONAL M6 LATON	HEXAGONAL NUT M6 BRASS	6	6	6				
	Q262040000	ARANDELA GROW. A6 A,304	WASHER GROW. A6 A.304	6	6	6				
17	Q307035000	JUNTA TORICA AN-36 282333	O-RING AN-36 282333	1	1	1				
18	Z743601000	RESISTENCIA TANQUE	TANK RESISTOR	1	1	1				
19	Z743602000	SOPORTE RESISTENCIA TANQUE	TANK RESISTOR SUPPORT	1	1	1				
	Q232040000	ARANDELA A,6	WASHER A,6	1	1	1				
	Q162040000	TUERCA EXAGONAL M6	HEXAGONAL NUT M6	1	1	1				
20	Z602923000	SOPORTE PRESOSTATO	PRESSURE SWITCH SUPPORT	1	1	1				
	Q082032000	TORNILLO ALOMADO BZ-3,5x9,5	CURVED SCREW BZ-3.5x9.5	1	1	1				
	Q162040000	TUERCA EXAGONAL M6	HEXAGONAL NUT M6	1	1	1				
	Q232040000	ARANDELA A6	WASHER A6	1	1	1				
21	Z203013000	TORNILLO PRESOSTATO	PRESSURE SWITCH BOLT	1	1	1				
22	Z203012000	EMPALME PRESOSTATO	PRESSURE SWITCH CONNEX	1	1	1				
	Q307003000	JUNTA TOR.16,01x10,77x2,62	O-RING 16.01X10.77X2.62	3	3	3				
23	Z203011000	CAMARA PRESOSTATO	PRESSURE SWITCH	1	1	1				
24	3702400000	TUBO DE GOMA 8x4 D8*4	BLACK RUBBER PIPE Ø 8*4	1	1	1				
	P102154000	BRIDA ELASTICA TUBO	ELASTIC PIPE FLANGE	2	2	2				
25	Z103077000	RACORD EN Y	Y-CONNECTION		1	1				
26	Z713002000	PRESOSTATO SIMPLE	SIMPLE PRESSURE SWITCH	1	1	1				
27	Z713098000	PRESOTATO SEGURIDAD	SECURITY PRESOTATO		1	1				
28	Z718405000	TERMOSTATO DOBLE	DOUBLE THERMOSTAT	1	1	1				
29	R213004000	TERMOSTATO REARME MANUAL	MANUAL RESET THERMOSTAT	1	1	1				ELIMINADO 11.02.2013
29	12046165	TERMOSTATO SEGURIDAD 115°C	SECURITY THERMOSTAT 115°C	1	1	1				INTRODUCIDO 11.02.2013
30	N503017000	SOPORTE TERMOSTATO 1001713	THERMOSTAT SUPPORT 1001713	2	2	2				
31	Z602923000	SOPORTE PRESOSTATO	PRESSURE SWITCH SUPPORT			1				
	Q152004000	TORNILLO APLAST. M5x13 A 304	FLAT HEADED BOLT M5x13			1				
	Q082032000	TORNILLO ALOMADO BZ-3,5x9,5	CURVED SCREW BZ-3.5x9.5			2				
	Q162030000	TUERCA EXAGONAL M5	HEXAGONAL NUT M6			1				
	Q242030000	ARANDELA ABANICO A-5 A304	FAN WASHER A-5 A304			1				

MOD.		LAVAVAJILLAS DE CAPOTA		ZONA	PARTE FUNCIONAL ELECTRICA			PLANO	C-1887
ITEM	CODIGO	DENOMINACION	TEXTO	FI-100	FI-100 B	FI-100B BT UK			NOTAS
32	3702400000	TUBO DE GOMA 8x4 D8*4	BLACK RUBBER PIPE Ø 8*4	1	1	1			
	P102154000	BRIDA ELASTICA TUBO	ELASTIC PIPE FLANGE	1	1	2			
33	Z213059000	TRIPLE PRESOTATO 40-120-150	TRIPLE PRESOTATO 40-120-15	1	1	1			
34	Z208438000	CHAPA W TC 90°C	PLATE W TC 90°C	1	1	1			
35	Z203014000	TERMOSTATO CALDERIN	WASH DRUM THERMOSTAT	1	1	1			ELIMINADO 01.11.2012
35	12040858	TERMOSTATO CALDERIN	WASH DRUM THERMOSTAT	1	1	1			INTRODUCIDO 01.11.2012
	Q152024000	TORNILLO AVELLANADO M4x8	COUNTERSUNK BOLT M4x8	2	2	2			
36	3715520000	CANALETA UNEX 60,30,77	PIPING UNEX 60.30.77	3	3	3			
	Q419005000	REMACHE 4x8 ALMG3 / ALUMINIO	RIVET 4X8 ALMG3 / ALUMINIUM	4	4	4			
	Q221342000	REMACHE EXAGONAL M5	HEXAGONAL RIVET M5	1	1	1			
	Q232040000	ARANDELA A6	WASHER A6	2	2	2			
	Q162040000	TUERCA EXAGONAL M6	HEXAGONAL NUT M6	2	2	2			
	Q152004000	TORNILL, APLASTADO M5x13 A304	FLAT HEADED BOLT M5x13 A304	1	1	1			
	Z713035000	REGLETA 6 mm.	TERMINAL 6 mm.	1	1	1			
	R693010000	REGLETA 2,5MM TEKOX1106PL	TERMINAL 2,5MM TEKOX1106PL	1	1	1			
37	Z213014000	LIMITADOR TECASA P.	LIMITER TECASA P.	1	1	1			
38	Z203060000	AMARRE LIMITADOR TECASA	LIMITER FASTENING TECASA	1	1	1			
39	Z713055000	PROGRAMADOR CICLO 50HZ	PROGRAMMER 50HZ	1	1	1			
39	Z713039000	PROGRAMAD. CICLO 5LEVAS 60HZ	PROGRAMMER 5LEVAS 60HZ	1	1	1			
39	Z718937000	PROGRAMADOR 50HZ 6 LEVAS	PROGRAMMER 50HZ 6 LEVAS	1	1	1			
	Q042022000	TORNILLO AVELLANADO M4x15	COUNTERSUNK BOLT M4X15	2	2	2			
	Q221341000	REMACHE EXAGONAL M4	HEXAGONAL RIVET M4	2	2	2			
40	Z713037000	CAJA CUADRO ELECTRICO	SWITCHBOARD BOX	1	1	1			
41	Z203050000	CONTAC. SIRIUS 3R 230V.50-60	CONT. SIRIUS 3RT10 16-2AP02	3	3	3			
42	Z683069000	BORNA 16	TERMINAL 16	3	3	3			
	Z683097000	BORNA PASO WDU16 10204,8	STEP TERMINAL WDU16 10204.8	1	1	1			
	Z683070000	BORNA A TIERRA WEIDMULLER	TERMINAL TO EARTH WEIDMULL	1	1	1			
	12040923	BORNAS PORTA FUSIBLES 13A 4	FUSE HOLDER TERMINALS 13A	2	2	2			INTRODUCIDO 09.07.2012
	12040926	FUSIBLE 0,50A Ø5MM 20X5 UL	FUSE 0.50A UL 20X5 Ø5MM	4	4	4			INTRODUCIDO 09.07.2012
	Z683068000	SEÑALIZ.DEK-6WEIDMULLER	SIGNS DEK-6WEIDMULLER	1	1	1			
	Z683096000	TOPE FINAL WEW35 10590.0	FINAL STOP WEW35 10590.0	1	1	1			

MOD.	LAVAVAJILLAS DE CAPOTA	ZONA	PARTE FUNCIONAL ELECTRICA	PLANO	C-1887
------	------------------------	------	---------------------------	-------	--------

ITEM	CODIGO	DENOMINACION	TEXTO	FI-100	FI-100 B	FI-100B BT UK					NOTAS
43	R023013000	PRENSA ESTOPAS	STUFFING BOX	1	1	1					
44	Z683087000	CONTACTOR 3TF20 01-3AL2 230	CONTACTOR 3TF20 01-3AL2 230	1	1	1					
45	Z213007000	CONTACTOR 230 V. 50-60 HZ	CONTACTOR 230 V. 50-60 HZ	1	1	1					



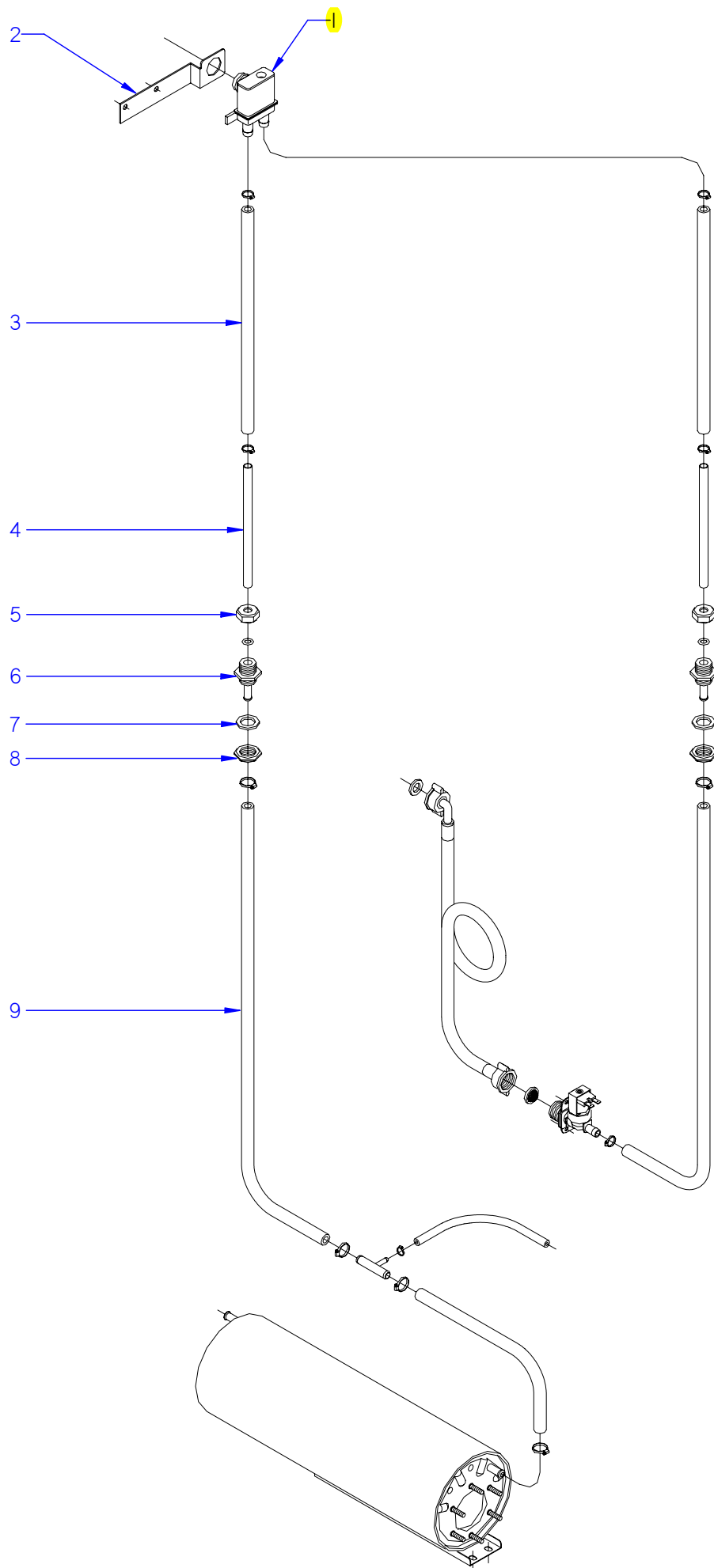

ITEM MARCADO EN COLOR = REPUESTO RECOMENDADO  
 COLOURED ITEM = RECOMMENDED SPARE PART

N plano	Firma	Fecha	Aparato	VALVULA ANTIRRETORNO	Lamina	Fagor Industrial S.Coop. <b>FAGOR</b>
C-1888	<i>[Signature]</i>	2007-07	LAVAVAJILLAS FI-100 A.R.	9	Oñate	

MOD.		LAVAVAJILLAS DE CAPOTA			ZONA	VALVULA ANTIRRETORNO					C-1888
ITEM	CODIGO	DENOMINACION	TEXTO	FI-100 A.R.							
1	Z231106000	VALVULA ANTIRRETORNO	CHECK VALVE	1							
2	Z711113000	SOPORTE VALVULA A.R.	VALVE SUPPORT	1							
3	3676900000	TUBO GOMA NEGRA D 17*10	BLACK RUBBER PIPE 17*10	2							
	Q881302000	ABRAZADERA 12-20	CLAMP 12*20	4							ELIMINADO 01.12.11
	12041731	ABRAZADERA INOX 12-22 MM	CLAMP INOX 12-22 MM	4							INTRODUCIDO 01.12.11
4	Z711114000	TUBO EMPALME	SPLICE PIPE	2							
5	Q223107000	TUERCA M.20x2.5	NUT M.20x2.5	2							
	Q307048000	JUNTA TORICA 9.12X16.18X3.53	O-RING 9.12X16.18X3.53	2							
6	Z711904000	PASAMUROS ACLARADO	RINSE BUSHING	2							
7	Q307032000	JUNTA 32X21X3	SEAL Ø 32X21X3	2							
8	Q223023000	TUERCA EXAGONAL 5-8 LATON	HEX NUT 5-8 BRASS	2							
9	3676900000	TUBO GOMA NEGRA 17*10	BLACK RUBBER PIPE 17*10	2							
	Q881302000	ABRAZADERA 12-20	CLAMP 12*20	2							



MOD.		LAVAVAJILLAS DE CAPOTA		ZONA	PIEZAS ESPECIFICAS PARA CULION					PLANO	
ITEM	CODIGO	DENOMINACION	TEXTO	VDS-120							NOTAS
	Z718002000	CUBA COM. EDESA LC-1000-1200		1							
	Z748009000	CAPO COMPLETO EDESA		1							
	Z200550000	ASA PUERTA COMPLETA		1							
	Z714502000	ADHESIVO CAPO CULION		1							
	Z711004000	ACUMULADOR CAPOTA 1503541		1							
	Z220903000	MANGUERA DESAGÜE		1							
	Z711005000	SOPORTE MOTOBOMBA		1							
	Z711006000	PROTECCION BOMBA		1							
	Z711007000	BOMBA DESAGUE		1							
	Z748012000	PANEL FRONTAL EDESA COMPL.		1							
	Z714501000	EMBELLECEDOR ADHES. VDS 120		1							
	R663056000	BUPIPONS AUTOADHESIVO		4							
	Z218011000	PRG. GICAR C.TECLADO		1							
	Z218013000	CABLEADO GICAR		1							
	P623017000	INTERRUPTOR GENERAL C.I.		1							
	R663036000	FIJACION CIRCUITO		7							
	Z218017000	SOPORTE PILOTOS COMPLETO		1							
	R693056000	PILOTO AMBAR 41227000A4		1							
	Z218012000	PRG. GICAR C.RELES		1							
	T133007000	DISTANCIADOR M3		4							
	Z718005000	SOPORTE COMPONENTES COMP.		1							
	T302829000	DISTANCIADOR COMPONENTES		3							
	Z268003000	TERMOMETRO GICAR		1							
	Z268004000	SONDAS TEMPERATURA GICAR		2							
	Z748008000	SOPORTE BULBO TERMOSTATO		1							
	Z718004000	AMARRE SONDA		1							
	Z713098000	PRESOSTATO SEGURIDAD		1							
	Z103077000	RACORD EN Y		1							
	P443060000	TAPON		1							
	Z203014000	TERMOSTATO CALDERIN		1							
	Z748027000	REGU. TERMOS. TANQUE 60 °C		1							





# FI - 100 , FI - 120 , FI - 120 T , KM - 120 , MLC - 120

④

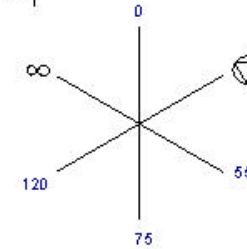
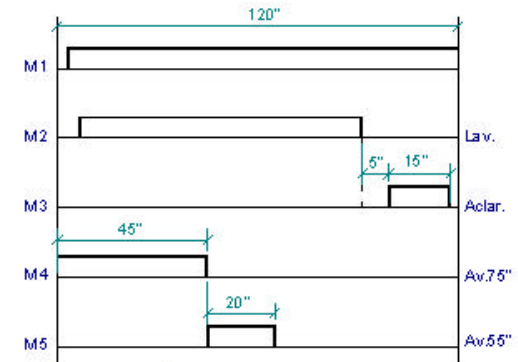
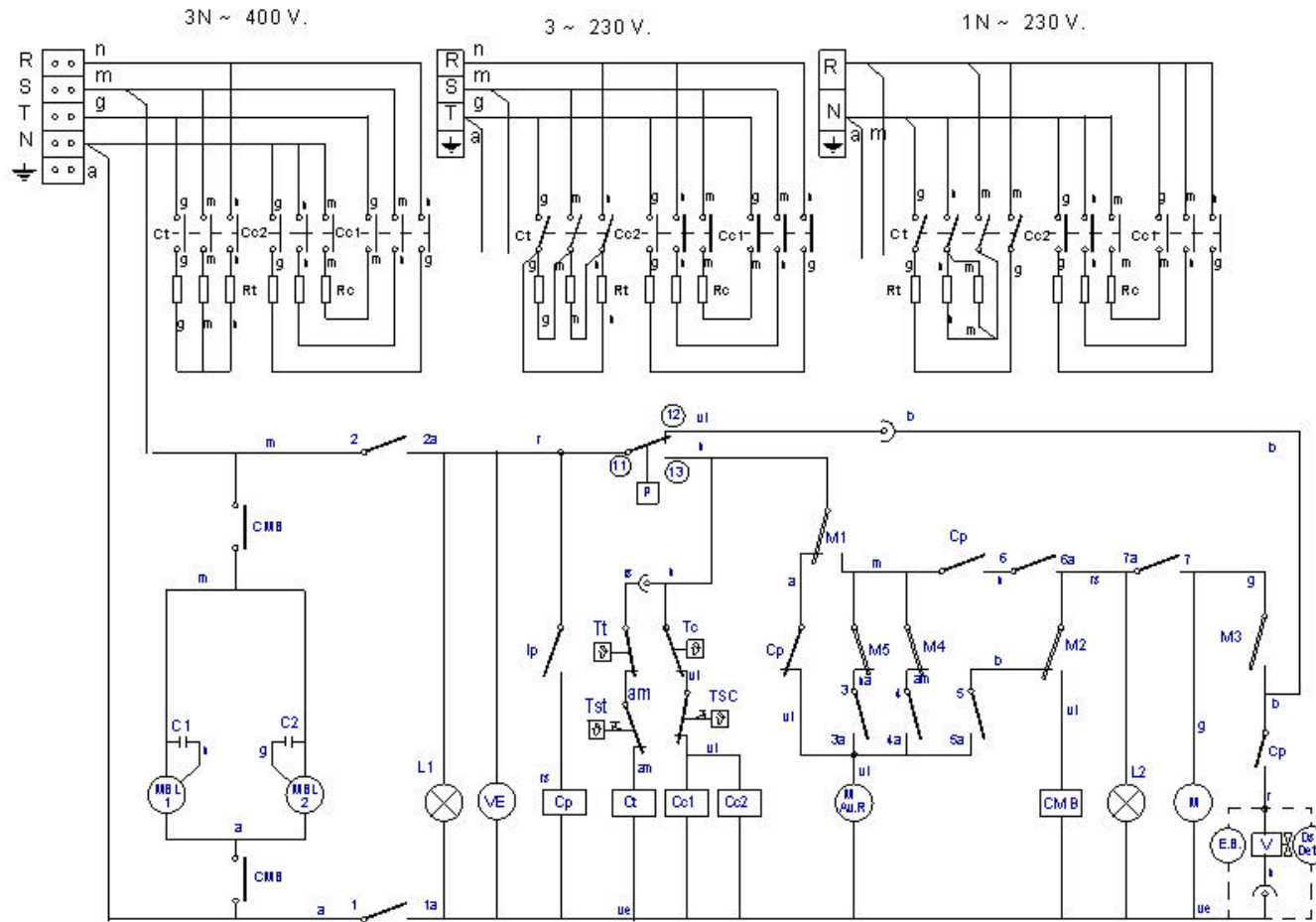

IG	1 1a	2 2a	3 3a	4 -4a	5 -5a	6 6a	7 -7a
0							
55	X	X	X	X		X	X
75	X	X		X		X	X
120	X	X				X	X
∞	X	X			X	X	

Z71 3032000

Esquema teórico adhesivo			Z-713032			
Zk./Nº	Pieza	Cant.	Materiales/Material	Klas. zk./Nº Clas.	Gaiuzal akaberat/Tratam. larru	
Zk./Nº	Aktibatza/Modifikazioak		Norm. proposatua/Proposeta de	Data/Feixa	Peidoi orokorrak To kiari klas. geterak	
1	Introducir cable negro		M. Maillo	14-6-2002		
2	Cambiar de negro a rosa en Tt		M. Maillo	03-01-2003	- 5 ±	
3	Cambiar de posición Cp		M. Maillo	26-02-2007	50 + 100 ±	
4	MOVIL FRIT modelos sartas		m gangotit	2007-04-18	> 100±	
-	-		-	-	25 + 50 ±	
	Siraditza/Plana	Data/Feixa	 Fagor Industrial, Koop. Ek. M. gaita		Gaiuzal perdoia Mecanizado especial	
	Marratza/Dibitado	S. N.-			12-11-2001	
	Proiektatza/Proiektado	-			-	
	Egiaztatza/Comprobado	<i>EGIAZTATUA</i>			-	
	Eskala/Escala	<h2>LAVAVAJILLAS</h2>			Plano zk./Plano Nº <b>HC-17386</b> - 04	
						Zk. ord. d.t.
						Zk. gaitk. ord.

Plano katezko datuak erabiliz, ezberdiztatuz, gure balazterekin gabe.

# FI 120 CLINIC LINE, FI 100B BT

3N ~ 380/415V.

3 ~ 230V.

1N ~ 240V.

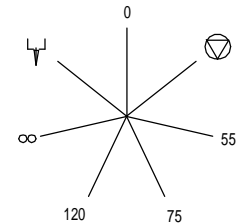
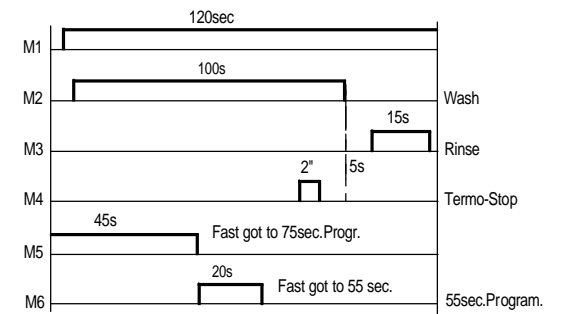
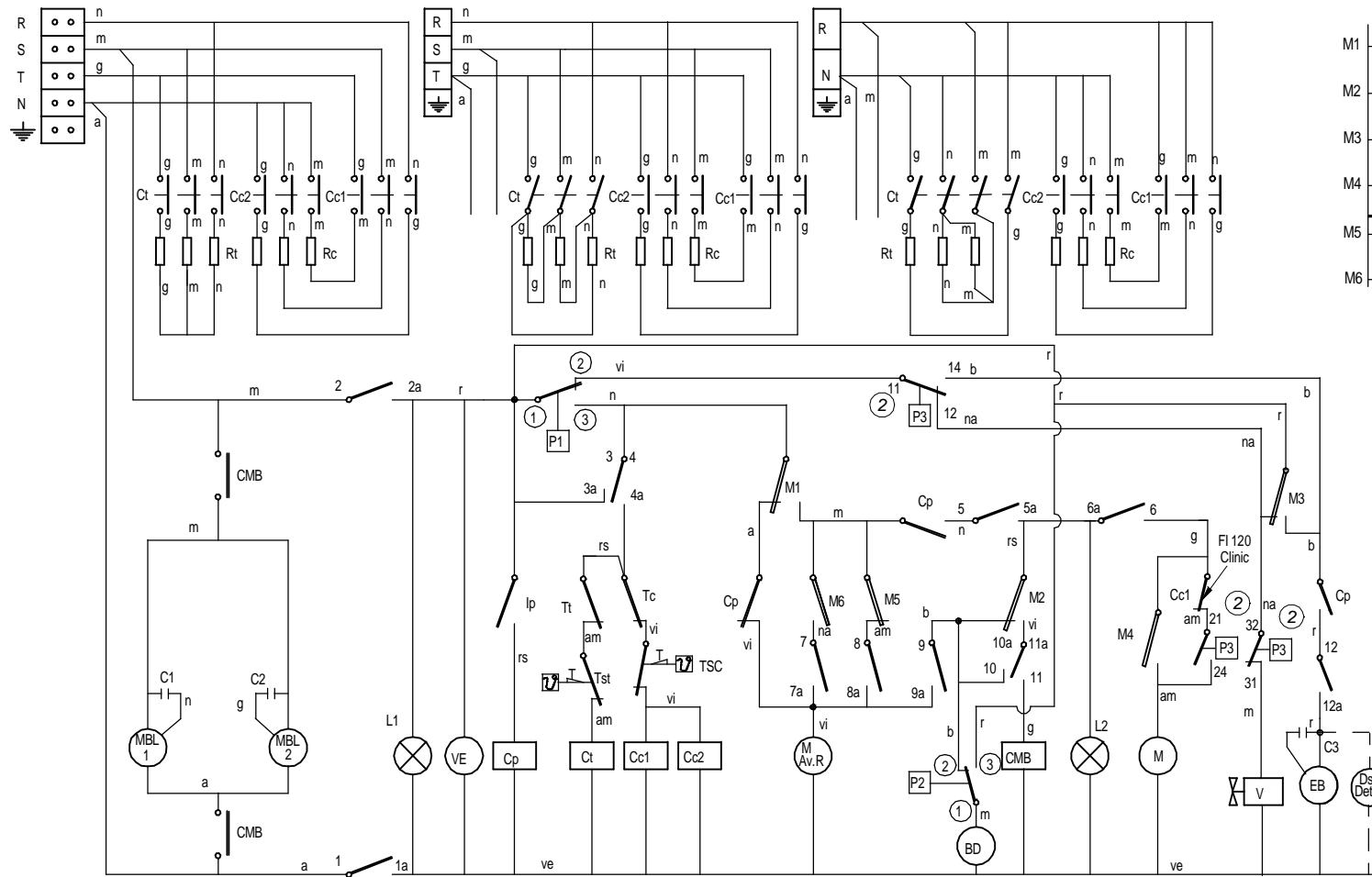

IG	1 1a	2 2a-3a	3 3a	4 4a	5 5a	6 6a	7 7a	8 8a	9 9a	10 10a	11 11a	12 12a
0												
∞	X	X		X							X	X
55	X	X		X	X	X	X	X			X	X
75	X	X		X	X	X		X			X	X
120	X	X		X	X	X					X	X
∞	X	X		X	X				X		X	X
∞	X	X	X		X	X				X		

Z718939000

ESQUEMA TEORICO 120 Clinic Line, 100B BT				Z718939000
Zk./Nº	Pieza	Cant.	Materia/Material	Klas. zk/Nº Clas. Gainazal akabera/Tratamiento
Zk./Nº	Aldaketa/Modificaciones		Nork proposatua/Propuesta de	Data/Fecha Perdoi orokorrak Tolerancias generales
1	Introducir FI100B BT		Eneritz	22-01-2007 < 5 ± 50 ÷ 100 ±
2	Se sustituyen P3, P4 y P5 por el triple presostato P3		MALBES	22-06-2007 5 ÷ 25 ± >100±
-	-		-	25 ÷ 50 ± α ±
-	-		-	-
Marratzua/Dibujado	Sinadura/Firma	Data/Fecha	 Fagor Industrial, Koop. Elk. Mugatua	Gainazal perdoia Mecanizado superficial
Proiektatua/Proyectado	M.Maillio	22-05-2005		Plano Zk./Plano Nº HC-17804 -02
Egiaztatua/Comprobado	M.Maillio	22-05-2005		
Eskala/Escala				Plano Zk./Plano Nº HC-17804 -02
Plano hau ezin daiteke erabili, ez berrizatu, gure baimenik gabe.				Zk. ord. du Zk.gaitik ord.

# FI - 120 B, FI - 100 B

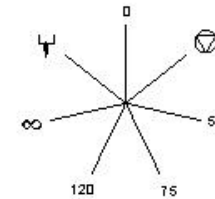
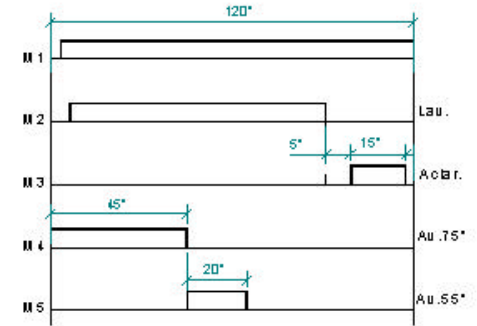
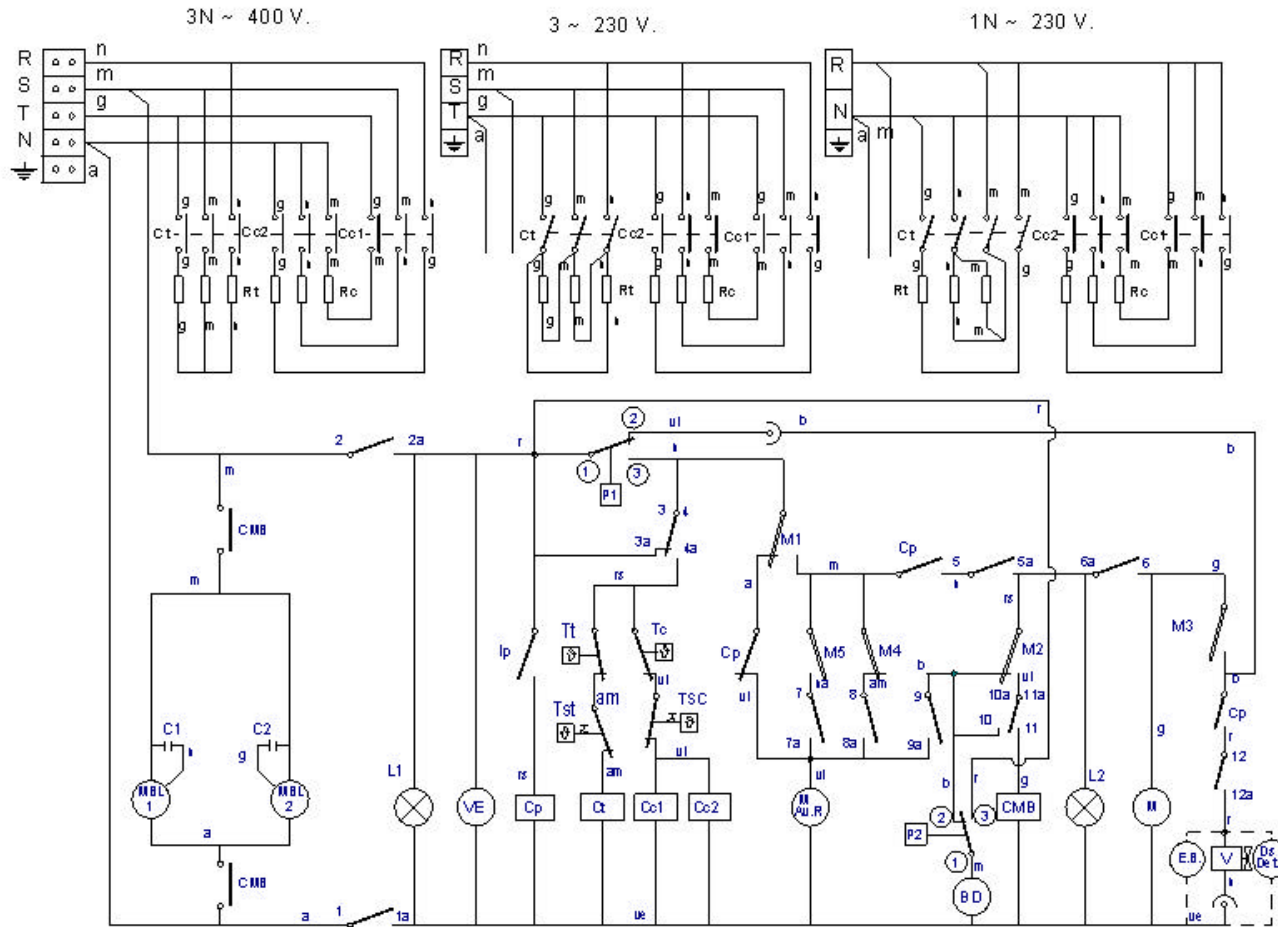

	1	2	3	4	5	6	7	8	9	10	11	12
0	1a	2a-3a	4a	5a-6a	7a-8a	9a	10a-11a	12a				
0												
55	X	X		X	X	X	X	X				X
75	X	X		X	X	X		X				X
120	X	X		X	X	X						X
60	X	X		X	X				X			X
120	X	X	X		X	X				X		

Z713096000

ESQUEMA TEORICO ADHESIVO				Z713096000	
Zk./N°	Peza	Cant.	Materia/Material	Klas. zk./N° Clas.	Gaiazal akabera/Tratam. k. ind.
Zk./N°	Aldaketa/Modifikazioak		Nork proposatua/Proposeta de	Data/Feixa	Perdola orokorrak To krak klas. geterak
01	Cambiar de negro a rosa en Tt		M. Mallio	03-01-2003	
2	Cambiar de posición Cp		M. Mallio	26-02-2007	- 5 ±
-	-		-	-	5 + 25 ±
-	-		-	-	25 + 50 ±
-	-		-	-	0 ±
	Marrazta/Dibujado	Inzarbalza	Data/Feixa	 Fagor Industrial, Koop. Ek. M. gaita	Gaiazalperdoia Mecanizado espeziala
	Proiektatza/Proyektado	Inzarbalza	Data/Feixa		
	Egiazatza/Comprobado		Data/Feixa		
	Eskaia/Escala				
<b>LAVAVAJILLAS</b>					Plano Zk./Plano N° <b>HC-17463-02</b>
Plano katezko datuak erabiliz, ezberdiztatuz, gure balioekin gabe.					- Zk. ord. d.1
					- Zk. gaitk. ord.

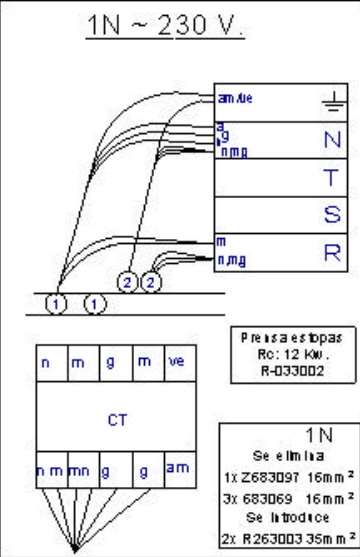
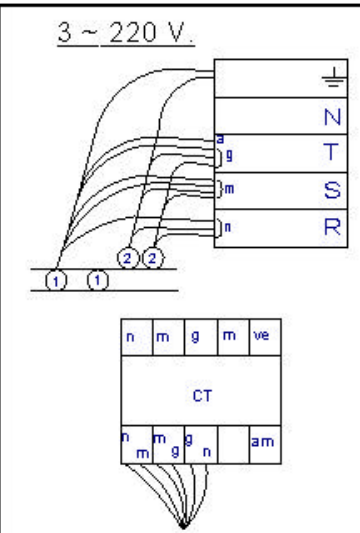
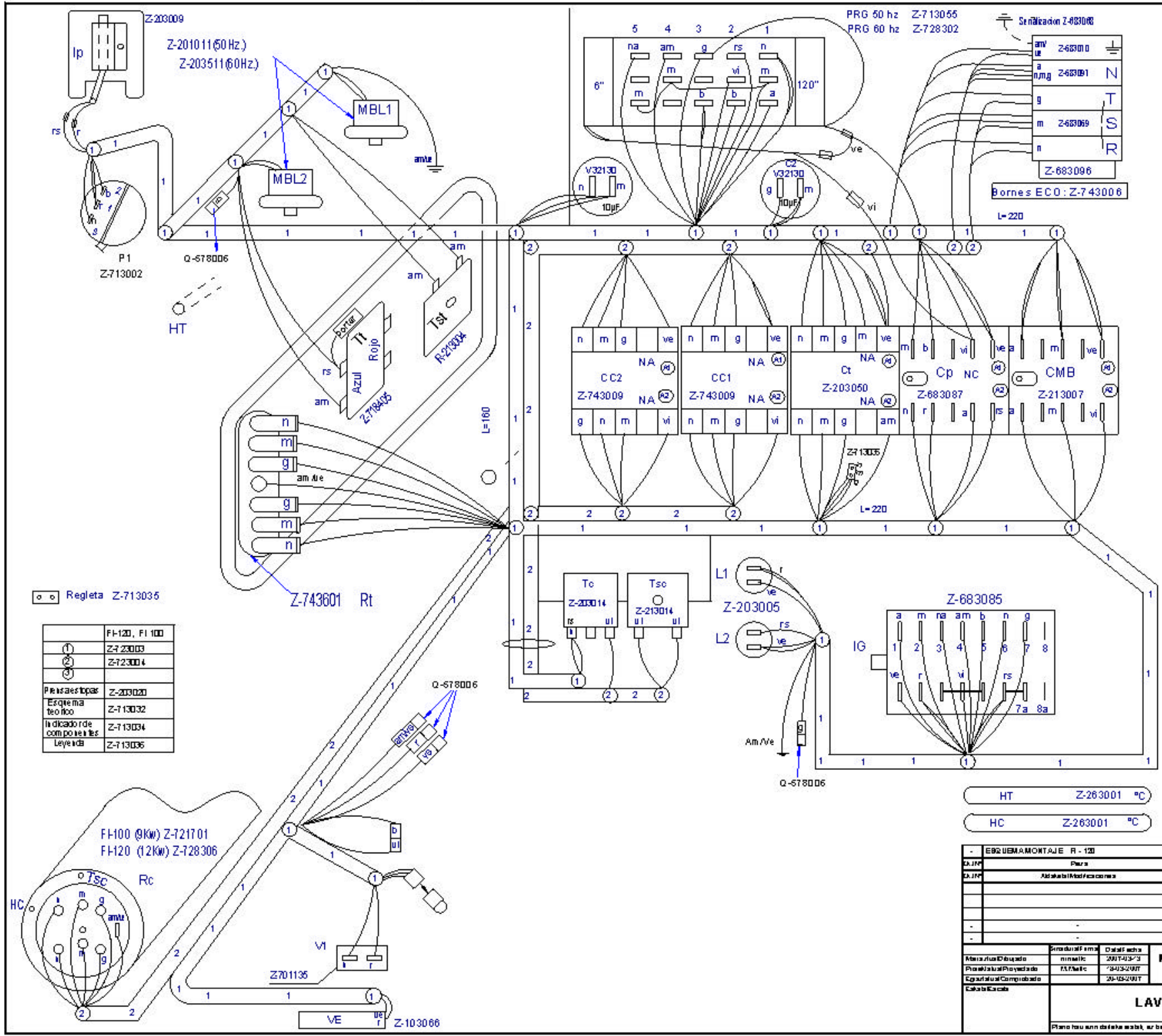

HT Z-263001 °C  
HC Z-263001 °C

EBO UEMAMONTAJE R-120		-72800 8000	
D.J.P.	Para	Materiales	Usos, ANP Clas
D.J.P.	Adaptación/Modificaciones	Mark. programada/Pl. opuestas de	Datos técnicos
			Perdidas eléctricas fórmula de generación
			5.1 [0.2] 50 - 100 [0.2]
			5.2 [0.2] 100 - 100 [0.2]
			5.3 [0.2] 100 - 100 [0.2]
			5.4 [0.2] 100 - 100 [0.2]
			5.5 [0.2] 100 - 100 [0.2]
			5.6 [0.2] 100 - 100 [0.2]
			5.7 [0.2] 100 - 100 [0.2]
			5.8 [0.2] 100 - 100 [0.2]
			5.9 [0.2] 100 - 100 [0.2]
			5.10 [0.2] 100 - 100 [0.2]
			5.11 [0.2] 100 - 100 [0.2]
			5.12 [0.2] 100 - 100 [0.2]
			5.13 [0.2] 100 - 100 [0.2]
			5.14 [0.2] 100 - 100 [0.2]
			5.15 [0.2] 100 - 100 [0.2]
			5.16 [0.2] 100 - 100 [0.2]
			5.17 [0.2] 100 - 100 [0.2]
			5.18 [0.2] 100 - 100 [0.2]
			5.19 [0.2] 100 - 100 [0.2]
			5.20 [0.2] 100 - 100 [0.2]
			5.21 [0.2] 100 - 100 [0.2]
			5.22 [0.2] 100 - 100 [0.2]
			5.23 [0.2] 100 - 100 [0.2]
			5.24 [0.2] 100 - 100 [0.2]
			5.25 [0.2] 100 - 100 [0.2]
			5.26 [0.2] 100 - 100 [0.2]
			5.27 [0.2] 100 - 100 [0.2]
			5.28 [0.2] 100 - 100 [0.2]
			5.29 [0.2] 100 - 100 [0.2]
			5.30 [0.2] 100 - 100 [0.2]
			5.31 [0.2] 100 - 100 [0.2]
			5.32 [0.2] 100 - 100 [0.2]
			5.33 [0.2] 100 - 100 [0.2]
			5.34 [0.2] 100 - 100 [0.2]
			5.35 [0.2] 100 - 100 [0.2]
			5.36 [0.2] 100 - 100 [0.2]
			5.37 [0.2] 100 - 100 [0.2]
			5.38 [0.2] 100 - 100 [0.2]
			5.39 [0.2] 100 - 100 [0.2]
			5.40 [0.2] 100 - 100 [0.2]
			5.41 [0.2] 100 - 100 [0.2]
			5.42 [0.2] 100 - 100 [0.2]
			5.43 [0.2] 100 - 100 [0.2]
			5.44 [0.2] 100 - 100 [0.2]
			5.45 [0.2] 100 - 100 [0.2]
			5.46 [0.2] 100 - 100 [0.2]
			5.47 [0.2] 100 - 100 [0.2]
			5.48 [0.2] 100 - 100 [0.2]
			5.49 [0.2] 100 - 100 [0.2]
			5.50 [0.2] 100 - 100 [0.2]
			5.51 [0.2] 100 - 100 [0.2]
			5.52 [0.2] 100 - 100 [0.2]
			5.53 [0.2] 100 - 100 [0.2]
			5.54 [0.2] 100 - 100 [0.2]
			5.55 [0.2] 100 - 100 [0.2]
			5.56 [0.2] 100 - 100 [0.2]
			5.57 [0.2] 100 - 100 [0.2]
			5.58 [0.2] 100 - 100 [0.2]
			5.59 [0.2] 100 - 100 [0.2]
			5.60 [0.2] 100 - 100 [0.2]
			5.61 [0.2] 100 - 100 [0.2]
			5.62 [0.2] 100 - 100 [0.2]
			5.63 [0.2] 100 - 100 [0.2]
			5.64 [0.2] 100 - 100 [0.2]
			5.65 [0.2] 100 - 100 [0.2]
			5.66 [0.2] 100 - 100 [0.2]
			5.67 [0.2] 100 - 100 [0.2]
			5.68 [0.2] 100 - 100 [0.2]
			5.69 [0.2] 100 - 100 [0.2]
			5.70 [0.2] 100 - 100 [0.2]
			5.71 [0.2] 100 - 100 [0.2]
			5.72 [0.2] 100 - 100 [0.2]
			5.73 [0.2] 100 - 100 [0.2]
			5.74 [0.2] 100 - 100 [0.2]
			5.75 [0.2] 100 - 100 [0.2]
			5.76 [0.2] 100 - 100 [0.2]
			5.77 [0.2] 100 - 100 [0.2]
			5.78 [0.2] 100 - 100 [0.2]
			5.79 [0.2] 100 - 100 [0.2]
			5.80 [0.2] 100 - 100 [0.2]
			5.81 [0.2] 100 - 100 [0.2]
			5.82 [0.2] 100 - 100 [0.2]
			5.83 [0.2] 100 - 100 [0.2]
			5.84 [0.2] 100 - 100 [0.2]
			5.85 [0.2] 100 - 100 [0.2]
			5.86 [0.2] 100 - 100 [0.2]
			5.87 [0.2] 100 - 100 [0.2]
			5.88 [0.2] 100 - 100 [0.2]
			5.89 [0.2] 100 - 100 [0.2]
			5.90 [0.2] 100 - 100 [0.2]
			5.91 [0.2] 100 - 100 [0.2]
			5.92 [0.2] 100 - 100 [0.2]
			5.93 [0.2] 100 - 100 [0.2]
			5.94 [0.2] 100 - 100 [0.2]
			5.95 [0.2] 100 - 100 [0.2]
			5.96 [0.2] 100 - 100 [0.2]
			5.97 [0.2] 100 - 100 [0.2]
			5.98 [0.2] 100 - 100 [0.2]
			5.99 [0.2] 100 - 100 [0.2]
			5.100 [0.2] 100 - 100 [0.2]

LAVAVAJILLAS

Plano D.1/Plano P  
HC-18054  
D. ind. de  
D. g. ind. de



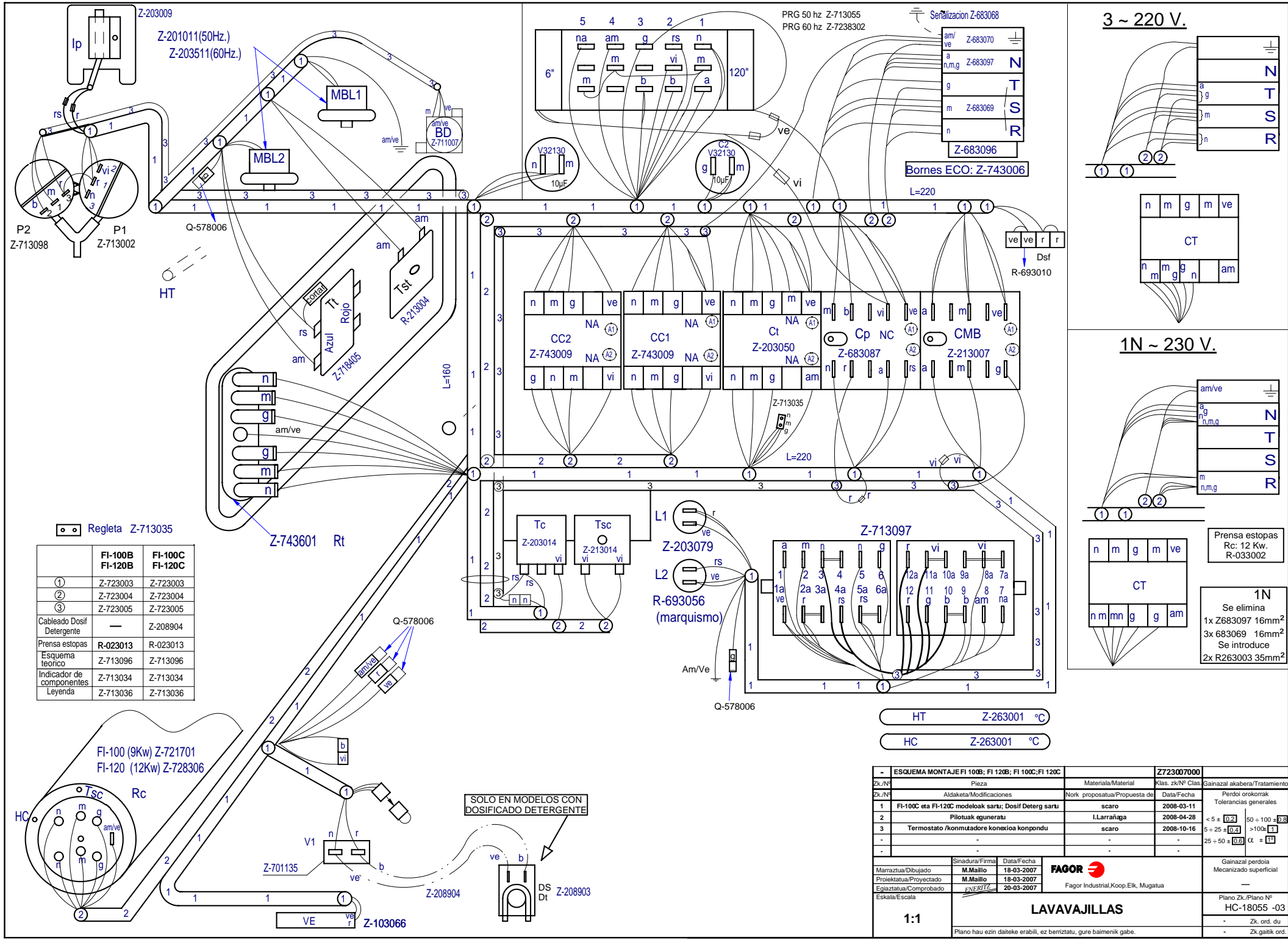

Regleta Z-713035

	FI-100B FI-120B	FI-100C FI-120C
①	Z-723003	Z-723003
②	Z-723004	Z-723004
③	Z-723005	Z-723005
Cableado Dosif Detergente	—	Z-208904
Prensa estopas	R-023013	R-023013
Esquema teorico	Z-713096	Z-713096
Indicador de componentes	Z-713034	Z-713034
Leyenda	Z-713036	Z-713036

HT Z-263001 °C  
HC Z-263001 °C

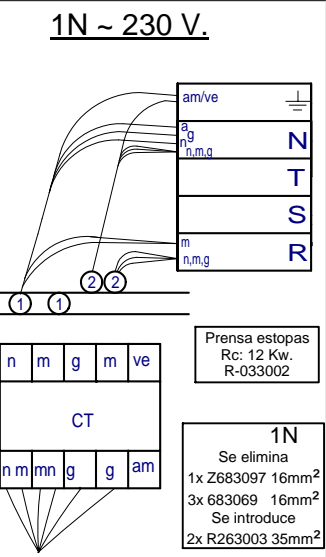
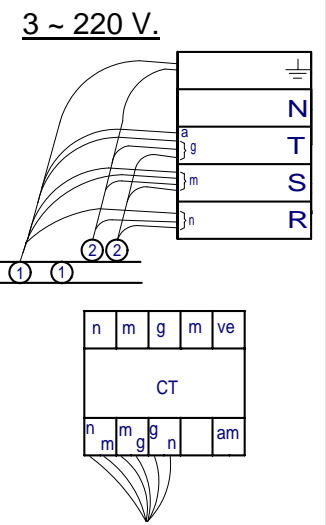

SOLO EN MODELOS CON DOSIFICADO DETERGENTE

ESQUEMA MONTAJE FI 100B; FI 120B; FI 100C; FI 120C				Z723007000	Gainazal akabera/Tratamiento													
Zk./Nº	Pieza	Materia/Material	Klas. zk/Nº Clas															
1	FI-100C eta FI-120C modeloak saru; Dosif Deterg saru	scaro	2008-03-11		Perdidi orokorak Tolerancias generales													
2	Pilotuak eguneratu	I.Larrañaga	2008-04-28	< 5 ± 0.2	50 ± 100 ± 0.8													
3	Termostato /konmutadore konexioa konpondu	scaro	2008-10-16	5 ± 25 ± 0.4	> 100 ± 1													
-	-	-	-	25 ± 50 ± 0.6	α = 1.5													
<table border="1"> <tr> <td>Marratuz/Dibujado</td> <td>Sinadura/Firma</td> <td>Data/Fecha</td> <td rowspan="4">  Fagor Industrial, Koop. Elk. Mugatua </td> </tr> <tr> <td>Proiektatua/Proyectado</td> <td>M.Mailló</td> <td>18-03-2007</td> </tr> <tr> <td>Egiaztatua/Comprobado</td> <td>M.Mailló</td> <td>18-03-2007</td> </tr> <tr> <td>Eskala/Escala</td> <td>ENERITZ</td> <td>20-03-2007</td> </tr> </table>				Marratuz/Dibujado	Sinadura/Firma	Data/Fecha	 Fagor Industrial, Koop. Elk. Mugatua	Proiektatua/Proyectado	M.Mailló	18-03-2007	Egiaztatua/Comprobado	M.Mailló	18-03-2007	Eskala/Escala	ENERITZ	20-03-2007	Gainazal perdoia Mecanizado superficial	
Marratuz/Dibujado	Sinadura/Firma	Data/Fecha	 Fagor Industrial, Koop. Elk. Mugatua															
Proiektatua/Proyectado	M.Mailló	18-03-2007																
Egiaztatua/Comprobado	M.Mailló	18-03-2007																
Eskala/Escala	ENERITZ	20-03-2007																
<h2>LAVAVAJILLAS</h2>				Plano Zk./Plano Nº HC-18055 -03														
1:1				- Zk. ord. du. - Zk.gatik ord.														
Plano hau ezin daiteke erabili, ez berrizatu, gure baimen gabe.																		

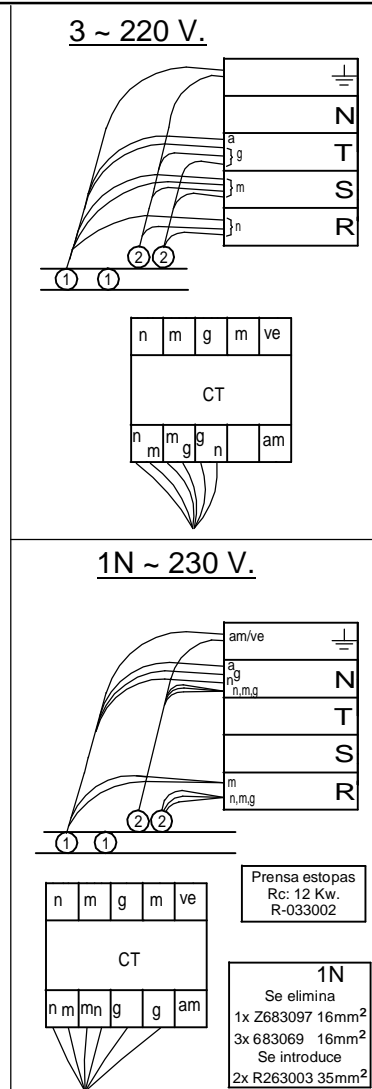
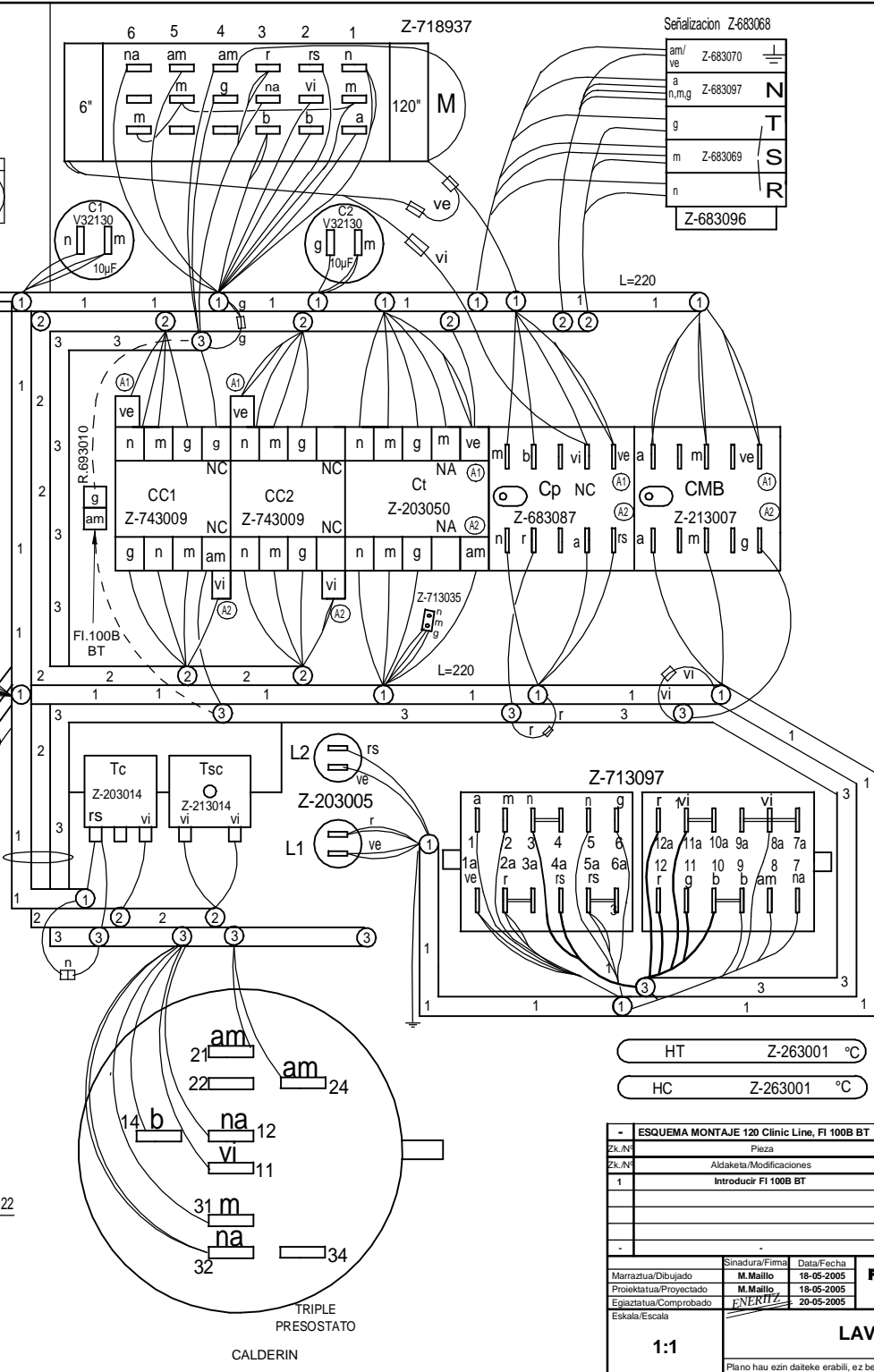
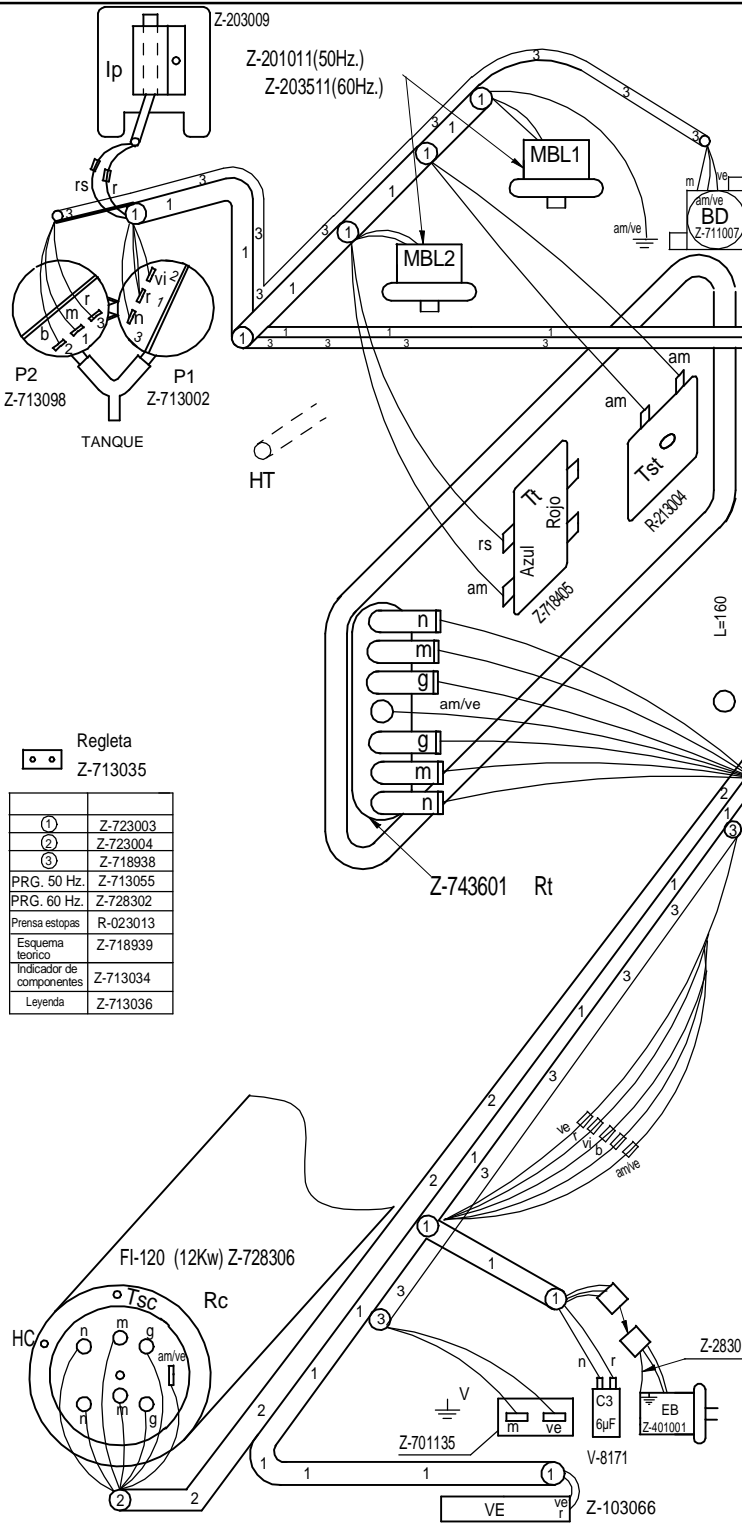

ESQUEMA MONTAJE 120 Clinic Line, FI 100B BT		Z718940000
Zk. Nº	Pieza	Materiales/Material
Zk. Nº	Aldaketa/Modificaciones	Nork proposatua/Propuesta de
1	Introducir FI 100B BT	Eneritz
		22-01-2007
		Perdori orokorrak Tolerantzia generales
		< 5 ± 0.2
		5 - 25 ± 0.4
		> 100 ± 1
		25 - 50 ± 0.6
		α ± 1
Sinadura/Firma		Data/Fecha
Marratua/Dibujado	M. Maillo	18-05-2005
Proiektatua/Proyectado	M. Maillo	18-05-2005
Egiaztatua/Comprobado	ENERITZ	20-05-2005
Eskala/Escala		Gainazal perdoia Mecanizado superficial
1:1		Gainazal perdoia Mecanizado superficial
Plano hau ezin daiteke erabili, ez berrizatu, gure balmenik gabe.		Plano Zk./Plano Nº HC-17805 - 1
		Zk. ord. du
		Zk.gatik ord.

# LEYENDA CAPOTA

	ESPAÑOL	FRANÇAIS	ENGLISH	DEUTSCH	ITALIANO
Ⓐ Ⓑ	Puntos de conexión con R	Points de conexión R	Connection point with R	<b>Anschlußpunkte mit R</b>	Punti di collegamento con R
BD	Bomba desagüe	Pompe de vidange	Drain pump	Abfließpumpe	Pompa scarico
C 1/2/3	Condensador	Condensateur	Condenser	Kondensator	Condensatore
CMB	Contactora bomba lavado	Contacteur pompe lavage	Wash pump contactor	Kontaktschütz Waschpumpe	Contattore pompa lavaggio
Cc 1/2	Contactora calentamiento calderin	Contacteur chauff. surchauffeur	Boiler heating contactor	Kontaktschütz Boilerheizung	Contattore riscaldamento boiler
Ct	Contactora calentamiento tanque	Contacteur chauffage cuve	Tank heating contactor	Kontaktschütz Heizung Tank	Contattore riscaldamento serbatoio
CP	Rele puerta	Relais porte	Door relay	Türrelais	Rele porta
Ds.Det.	Dosificador detergente	Dosueur de detergent	Detergent doser	Dosierer Spülmittel	Dosatore detersivo
E.B	Electrobomba de presión	Electropompe de pression	Electric pressure pump	Elektro-Drucksteigerungspumpe	Electropompa pressione
IG	Interruptor general	Interrupteur general	Main switch	Hauptschalter	Interruttore generale
IP	Micro puerta	Micro porte	Door microswitch	Mikroschalter Tür	Micro porta
L1	Piloto de encendido	Voyant fonctionnement	Operation light	Betriebsanzeigelampe	Spia accensione
L2	Piloto marcha	Voyant démarrage	Start light	Startanzeigelampe	Spia avvio
L3	Piloto máquina preparada	Voyant machine prêt	Light machine ready	Betriebsbereitschaftsanzeigelampe	Pilota macchina preparata
MBL 1/2	Bomba lavado	Pompe lavage	Wash pump	Waschpumpe	Pompa lavaggio
M	Motor programador	Moteur du programmateur	Motor programmer	Motor Programmiervorrichtung	Motore programmatore
M Av. R	Motor program. avance rápido	Moteur du progr.avance rapide	Motor program. rapid advance	Motor Programmiervorrich. schneller Vorlauf	Motore programmatore avanzamento rapido
M1	Micro programador marcha	Micro du programm. de marche	Micro programmer on	Motor Programmiervorrich. Betrieb	Micro programma. di funzionamento
M2	Micro programador lavado	Micro du programm. de lavage	Micro programmer wash	Motor Programmiervorrich. Waschen	Micro programmatore di lavaggio
M3	Micro programador aclarado	Micro du programm. de rinçage	Micro programmer on	Motor Programmiervorrich. Spülen	Micro programmatore di risciacquo
M4	Micro programador Termo-stop	Micro du programm. Thermo-stop	Micro programmer Thermo-stop	Motor Programmiervorrich. Thermo-Stop	Micro programmatore Termo-stop
M5	Micro programador avance	Micro du programm. avance	Micro programmer advance	Motor Programmiervorrich. Vorlauf	Micro programmatore avanzamento
M6	Micro programador avance	Micro du programm. avance	Micro programmer advance	Motor Programmiervorrich. Vorlauf	Micro programmatore avanzamento
P, P1, P5	Presostato	Pressostat	Pressure switch	Druckwächter	Pressostato
P2, P3, P4	Presostato limitador	Pressostat de sécurité	Hi-limit pressure switch	Begrenzer Druckwächter	Pressostato limitatore
R	Rele de Generador de A.C.	Relais du Générateur	Generator rele	Relais Generator	Rele Generatore
Ⓡ Ⓝ	Toma de alimentac. Generador A.C.	Alimentation generateur	Water heater feeding	Stromversorgungsanschluß Gener.	Alimentazione generatore
RC	Resistencia calderin	Resistance surchauffeur	Boiler heating element	Heizwiderstand Boiler	Resistenza boiler
RT	Resistencia tanque	Resistance cuve	Tank heater	Heizwiderstand Tank	Resistenza serbatoio
Tt	Termostato tanque	Thermostat de cuve	Tank thermostat	Thermostat Tank	Termostato serbatoio
TC	Termostato calderin	Thermostat surchauffeur	Boiler thermostat	Thermostat kessel	Termostato boiler
Tst	Limitador tanque	Limiteur de cuve	Tank limiter	Begrenzer Tank	Limitatore serbatoio
TSC	Limitador calderin	Limiteur surchauffeur	Boiler Hi-limit	Begrenzer Boiler	Limitatore boiler
TSTP	Termostato termo-stop	Thermostat Thermo-stop	Thermo-stop Thermostat	Thermostat Thermo-stop	Termostato Thermo-stop
V	Electrovalvula llenado y aclarado	Electrovan. remplissage rinçage	Fill and rinse valve	Elektroventil Füllen und Spülen	Elettroval. riempimento e risciacquo
VE	Ventilador cuadro eléctrico	Ventilateur tableau électrique	Switchboard fan	Schalttafelventilator	Ventilatore quadro elettrico
COLOR	COLORES	COULEURS	COLOUR	FARBEN	COLORE
a =	Azul	Bleu	Blue	Blau	Blu
am =	Amarillo	Jaune	Yellow	Gelb	Giallo
am/ve =	Amarillo/verde	Jaune / vert	Yellow / green	Gelb/grün	Giallo/verde
b =	Blanco	Blanc	White	Weiß	Bianco
g =	Gris	Gris	Grey	Grau	Grigio
m =	Marrón	Marron	Brown	Braun	Marrone
n =	Negro	Noir	Black	Schwarz	Nero
na =	Naranja	Orange	Orange	Orange	Arancio
r =	Rojo	Rouge	Red	Rot	Rosso
rs =	Rosa	Rose	Pink	Rosa	Roseo
ve =	Verde	Vert	Green	Grün	Verde
vi =	Violeta	Violet	Purple	Violett	Viola

Z-713036