

DESPIECE TÉCNICO TECHNICAL PARTS

Lavavajillas
Dishwasher

MODELOS

CO-352 COLD / DD / B / B DD
CO-402 COLD / DD / B / B DD

Diciembre 2014 December
Revisado Mayo 2015 May Revised



C-3329

N plano / Drawing N.

Iban R

Firma / Signature

2014-12

Fecha / Date

CO-352-402 COLD GLASSWASHER

Aparato / Appliance

ARMAZON / FRAME

1

Lamina / Sheet

Oparte

Fagor Industrial S. Coop. **FAGOR**

ITEM MARCADO EN COLOR = REPUESTO RECOMENDADO
COLOURED ITEM = RECOMMENDED SPARE PART

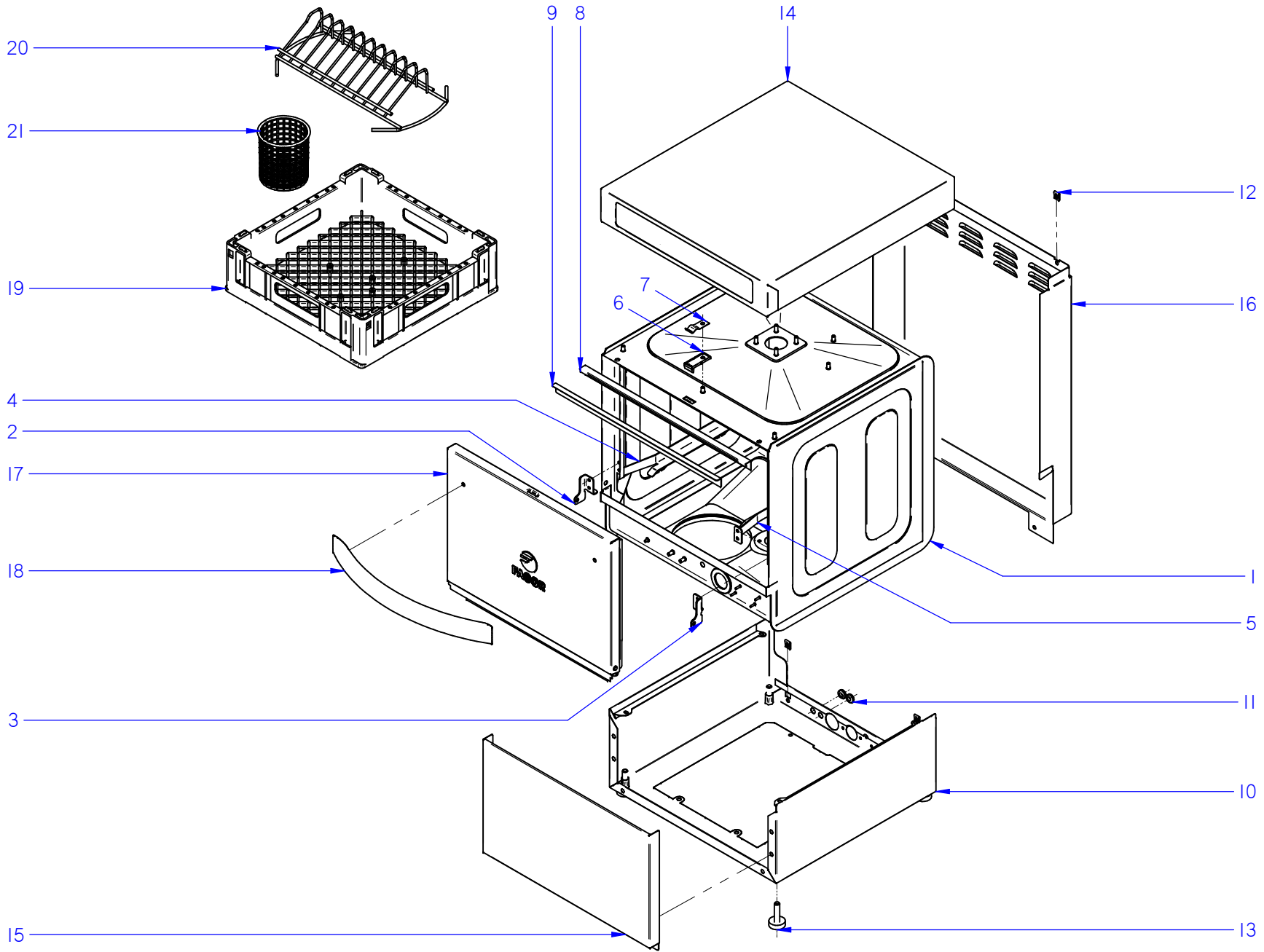

ZONA / ZONE	ARMAZON / FRAME	LÁMINA / DRAWING	C-3329	FAGOR 
--------------------	------------------------	-------------------------	---------------	--

ITEM	REFERENCIA REFERENCE	DENOMINACIÓN	DENOMINATION	CO-352 COLD	CO-402 COLD						RECOMMENDED			NOTAS / NOTES
1	12047953	CUBA SOLDADA CO-350	WELDED TUB CO-350	1	-									
1	12101982	CUBA SOLDADA CO-400	WELDED TUB CO-400	-	1									
1	12113475	CUBA SOLDADA CO-400 SOFT	WELDED TUB CO-400 SOFT	-	-									
2	12048627	SOPORTE PUERTA IZQUIERDO	LEFT DOOR SUPPORT	1	1									
3	12048774	SOPORTE PUERTA DERECHO	RIGHT DOOR SUPPORT	1	1									
4	12049133	GUIA CESTILLO IZQU CO-350	LEFT BASKET GUIDE CO-350	1	-									
4	12102193	GUIA CESTILLO IZQU CO-400	LEFT BASKET GUIDE CO-400	-	1									
5	12049135	GUIA CESTILLO DCHA CO-350	RIGHT BASKET GUIDE CO-350	1	-									
5	12102194	GUIA CESTILLO DCHA CO-400	RIGHT BASKET GUIDE CO-400	-	1									
6	12087183	MACHO CIERRE PUERTA	DOOR LOCK	1	1									
7	12087186	FLEJE_CIERRE_PUERTA	DOOR LOCK SPRING	1	1									
8	12087200	PERFIL VAHOS CO-350	STEAM SEAL CO-350	1	-									
8	12101867	PERFIL VAHOS CO-400	STEAM SEAL CO-400	-	1									
9	12102061	PERFIL JUNTA VAHOS CO-350	STEAM PROFILE SEAL CO-350	1	-									
9	12102035	PERFIL JUNTA VAHOS CO-400	STEAM PROFILE SEAL CO-400	-	1									
10	12049271	BASE SOLDADA CO-350	WELDED BASE CO-350	1	-									
10	12101978	BASE SOLDADA CO-400	WELDED BASE CO-400	-	1									
11	12112707	PASAMUROS 18x8x6 CHAPA E=1	1MM SHEET BUSHING 18x8x6	2	2									
12	12087215	TUERCA RÁPIDA M5	FAST NUT M5	4	4									
13	12024163	PATA REGULABLE	REGULABLE FOOT	4	4									
14	12116665	PANEL SUPERIOR 352	TOP PANEL 352	1	-									
14	12118815	PANEL SUPERIOR 402	TOP PANEL 402	-	1									
15	12048562	PANEL FRONTAL CO-350	FRONT PANEL CO-350	1	-									
15	12101870	PANEL FRONTAL CO-400	FRONT PANEL CO-400	-	1									
16	12048645	PANEL POSTERIOR CO-350	REAR PANEL CO-350	1	-									
16	12101871	PANEL POSTERIOR CO-400	REAR PANEL CO-400	-	1									
17	12049066	PUERTA SOLDADA CO-350	WELDED DOOR CO-350	1	-									
17	12102007	PUERTA SOLDADA CO-400	WELDED DOOR CO-400	-	1									
18	12049468	ASA LAVAVASOS	GLASSWASHER HANDLE	1	1									
19	12024550	CESTILLO 350	BASKET 350	2	-									
19	12025069	CESTILLO 400	BASKET 400	-	2									

ZONA / ZONE

ARMAZON / FRAME

LÁMINA / DRAWING

C-3329



ITEM	REFERENCIA REFERENCE	DENOMINACIÓN	DENOMINATION	CO-352 COLD	CO-402 COLD														RECOMMENDED				NOTAS / NOTES
20	12024286	SUPLEMENTO PLATILLOS 350	SMALL DISHES SUPPLEMENT 350	1	-																		
20	12025030	SUPLEMENTO PLATILLOS 400	SMALL DISHES SUPPLEMENT 400	-	1																		
21	12025242	GESTILLO PORTACUBIERTOS	CUTLERY BASKET	1	1																		

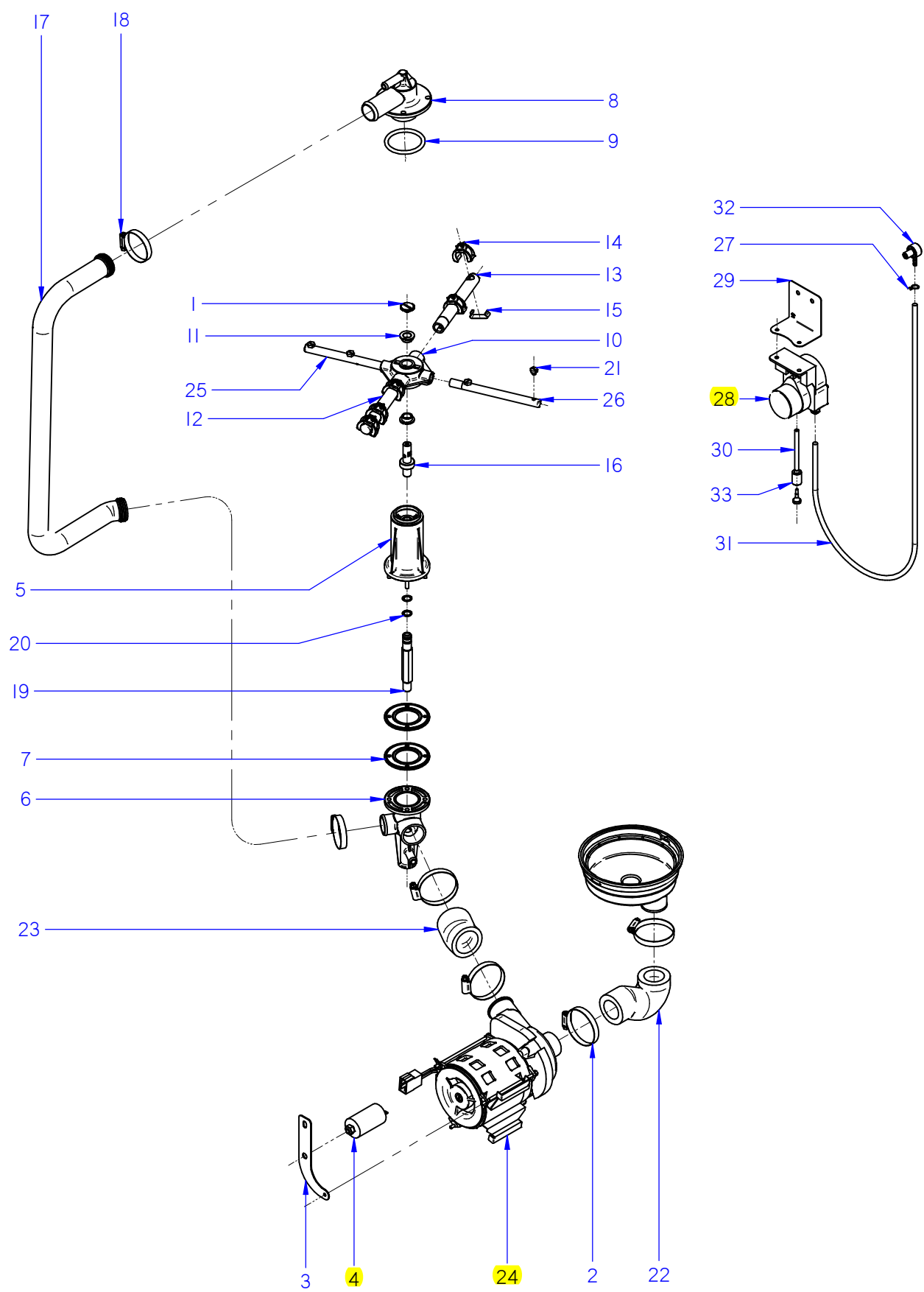

ITEM MARCADO EN COLOR = REPUESTO RECOMENDADO
 COLOURED ITEM = RECOMMENDED SPARE PART

N plano / Drawing N.	Firma / Signature	Fecha / Date	Aparato / Appliance	PARTE FUNCIONAL LAVADO / WASHING FUNCTIONAL PART	Lamina / Sheet	Fagor Industrial S.Coop. FAGOR
C-3330	Iban R.	12/2014	CO-352-402 COLD / DD GLASSWASHER		2	Oñate

ZONA / ZONE	PARTE FUNCIONAL LAVADO / WASHING FUNCTIONAL PART	LÁMINA / DRAWING	C-3330	FAGOR 
-------------	--	------------------	--------	---

ITEM	REFERENCIA REFERENCE	DENOMINACIÓN	DENOMINATION	CO-352 COLD	CO-402 COLD							RECOMMENDED	ELIMINADO ELIMINATED	INTRODUCIDO INTRODUCED	NOTAS / NOTES
1	12009829	TORNILLO ESPECIAL M.5X0.8	SPECIAL SCREW M.5X0.8	1	1										
2	12009962	ABRAZADERA 40-60	40-60 CLAMP	4	4										
3	12111848	SOPORTE BOMBA LAVADO 350	WASHIG PUMP SUPPORT 350	1	-										
3	12111106	SOPORTE BOMBA LAVADO 400	WASHIG PUMP SUPPORT 400	-	1										
4	12024346	CONDENSADOR 10MF	10MF CAPACITOR	1	1							X			
5	12112971	SOP. DISTRIBUIDOR INFERIOR	LOWER SPRY-ARM SUPPORT	1	1										
6	12024703	PASAMUROS CESTO CUADRADO	SQUARE BASKET BUSHING	1	1										
7	12023533	JUNTA ESTANQUEIDAD	SEALING GASKET	2	2										
8	12113028	SOP. DISTRIBUIDOR SUPERIOR	UPPER SPRY-ARM SUPPORT	1	1										
9	12010079	JUNTA TOR.50.17X60.83X5.3	O-RING 50.17X60.83X5.3	1	1										
10	12025216	CRUCETA	CROSSBRACE	2	2										
11	12024086	CASQUILLO CRUCETA	CROSSBRACE BUSHING	2	2										
12	12019827	RAMA LAVADO A 350	WASHING BRANCH A 350	2	-										
12	12022381	RAMA LAVADO A 400	WASHING BRANCH A 400	-	2										
13	12019857	RAMA LAVADO B	WASHING BRANCH B	2	-										
13	12022382	RAMA LAVADO B 400	WASHING BRANCH B 400	-	2										
14	12023732	TOBERA LAVADO	WASHING NOZZLE	10	12										
15	12023710	ENGANCHE TOBERA LAVADO	WASHING NOZZLE ENGAGE	10	12										
16	12025114	EJE	SHAFT	2	2										
17	12024059	ARBOL LAVADO 350	WASHING TREE 350	1	-										
17	12025154	ARBOL LAVADO 400	WASHING TREE 400	-	1										
18	12009986	ABRAZADERA 32-50L	32-50L CLAMP	2	2										
19	12023801	EMPALME ACLARADO	RINSE CONNECTION	1	1										
20	12009911	JUNTA TO.10.82X14.38X1.78	O-RING 10.82X14.38X1.78	2	2										
21	12024252	TOBERA ACLARADO 350	RINSING NOZZLE	8	10										
22	12023670	CODO ASPIRACION	SUCTION ELBOW	1	1										
23	12023607	CODO IMPULSION	EXPULSION ELBOW	1	1										
24	12023429	BOMBA LAVADO 50/60HZ 260KW	WASHING PUMP 50/60HZ 260KW	1	1							X			
25	12020475	RAMA ACLARADO A 350	RINSING BRANCH A 350	1	-										
25	12022613	RAMA ACLARADO A 400	RINSING BRANCH A 400	-	1										
26	12020476	RAMA ACLARADO B 350	RINSING BRANCH B 350	1	-										
26	12022710	RAMA ACLARADO B 400	RINSING BRANCH B 400	-	1										

ZONA / ZONE	PARTE FUNCIONAL LAVADO / WASHING FUNCTIONAL PART	LÁMINA / DRAWING	C-3330	FAGOR 
-------------	--	------------------	--------	---

ITEM	REFERENCIA REFERENCE	DENOMINACIÓN	DENOMINATION	CO-352 COLD	CO-402 COLD						RECOMMENDED	ELIMINADO ELIMINATED	INTRODUCIDO INTRODUCED	NOTAS / NOTES
	19022347	KIT DOSIFICADOR DETERGENTE EVO	DETERGENT DISPENSER KIT EVO											
27	12023707	BRIDA ELASTICA TUBO	ELASTIC CLAMP FOR PIPES	-	1									
28	12024216	DOSIFIC. DGTE REGULABLE G300	REGUL. DETERG. DISPENSER G300	-	1						X			
29	12049139	SOPORT. DOSIFICADORES	DISPENSERS SUPPORT	-	1									
30	12024139	CONDUCTO ASPIRACIÓN AZKOY CO	AZKOY SUCTION PIPE	-	1									
31	11000079	CONDUCTO DOSIF. TRANSP 6X4	DISPENSER TRANSPARENT PIPE	-	1									
32	12024531	INYECTOR DETERGENTE INOX	DETERGENT INJECTOR	-	1									
33	12024353	PESO FILTRO	FILTER'S WEIGHT	-	1									

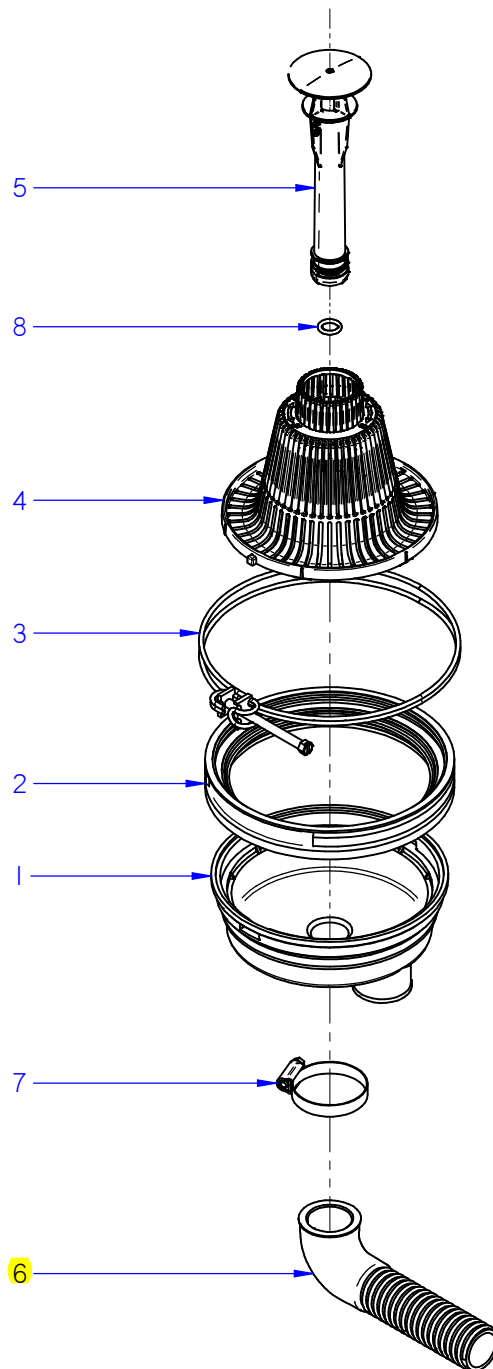

ITEM MARCADO EN COLOR = REPUESTO RECOMENDADO
 COLOURED ITEM = RECOMMENDED SPARE PART

N plano / Drawing N. C-3331	Firma / Signature Iban R.	Fecha / Date 12-2014	Aparato / Appliance PARTE FUNCIONAL LAVADO / WASHING FUNCTIONAL PART CO-352-402 COLD GLASSWASHER	Lamina / Sheet 3	Fagor Industrial S.Coop. FAGOR  Oñate
---------------------------------------	-------------------------------------	--------------------------------	--	----------------------------	--

ITEM	REFERENCIA REFERENCE	DENOMINACIÓN	DENOMINATION	CO-352-402 COLD								RECOMMENDED	ELIMINADO ELIMINATED	INTRODUCIDO INTRODUCED	NOTAS / NOTES
1	12112942	CUBETA CO-400	PAIL CO-400	1											
2	12024113	JUNTA CUBETA	PAIL SEAL	1											
3	12025195	ABRAZADERA CUBETA COMPLET	PAIL COMPLETE CLAMP	1											
4	12092003	FILTRO CO-400	CO-400 FILTER	1											
5	12120614	ALIVIADERO CO-400	CO-400 SPILLWAY	1											
6	12024114	MANGUERA DESAGUE	DRAINING PIPE	1								X			
7	12009986	ABRAZADERA 32-50L	32-50L CLAMP	1											
8	12104085	JUNTA TORICA ALIVIADERO	SPILLWAY O-RING	1											
	19013376	KIT BOMBA DE DESAGÜE	DRAINING PUMP KIT												

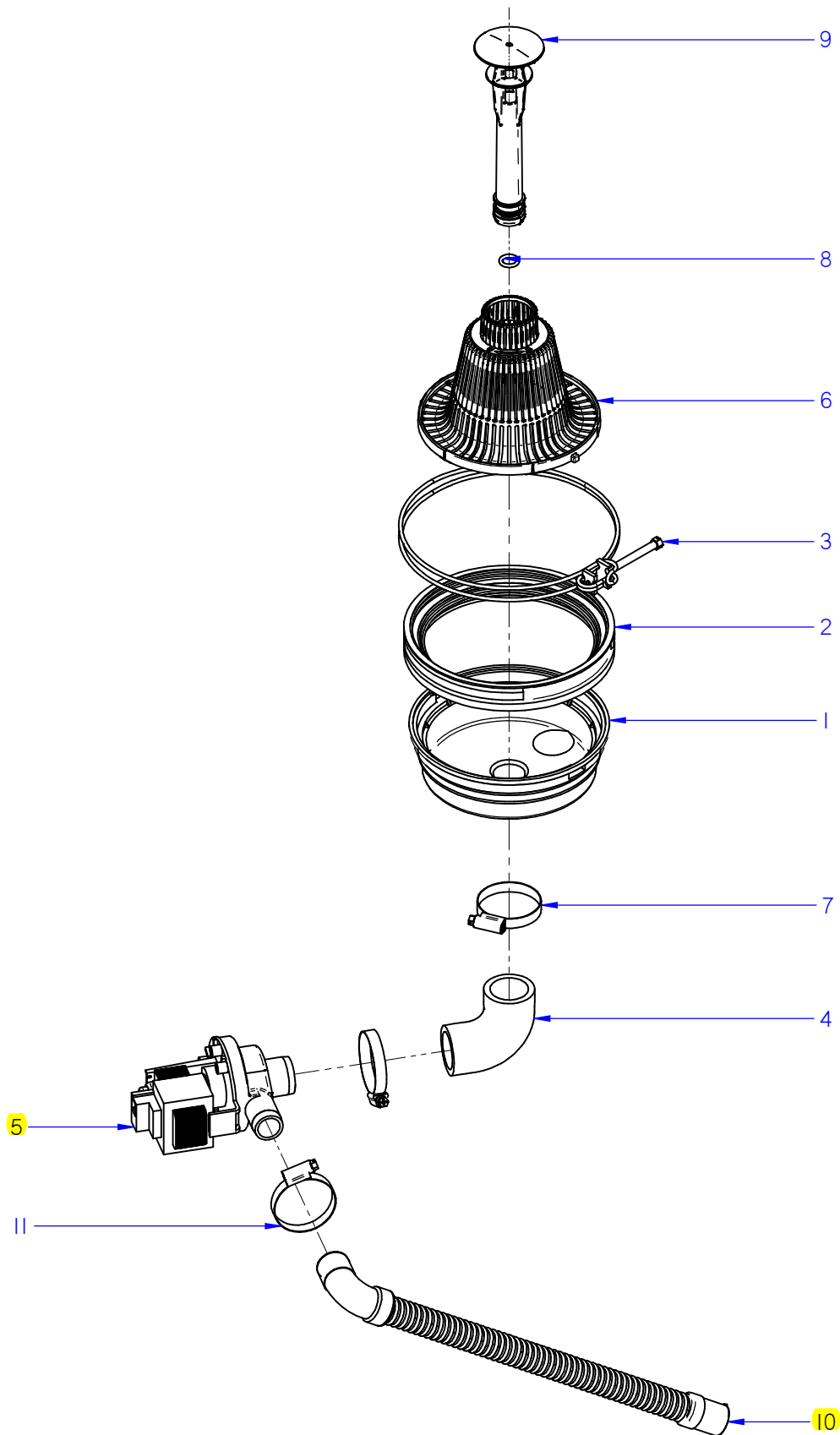

ITEM MARCADO EN COLOR = REPUESTO RECOMENDADO
 COLOURED ITEM = RECOMMENDED SPARE PART

N plano / Drawing N.	Firma / Signature	Fecha / Date	Aparato / Appliance	PARTE FUNCIONAL LAVADO / WASHING FUNCTIONAL PART	Lamina / Sheet	Fagor Industrial S.Coop. FAGOR
C-3332	Iban R.	12-2014	CO-352-402	COLD B GLASSWASHER	4	 FAGOR
						Oñate

ITEM	REFERENCIA REFERENCE	DENOMINACIÓN	DENOMINATION	CO-352-402 B												RECOMMENDED	ELIMINADO ELIMINATED	INTRODUCIDO INTRODUCED	NOTAS / NOTES
1	12112942	CUBETA CO-400	PAIL CO-400	1															
2	12024113	JUNTA CUBETA	PAIL SEAL	1															
3	12025195	ABRAZADERA CUBETA COMPLET	PAIL COMPLETE CLAMP	1															
4	12094016	CONDUCTO ASPIRACION	SUCTION PIPE	1															
5	12094265	BOMBA DESAGÜE 1N 50/60Hz 38W	DRAINING PUMP 1N 50/60Hz 38W	1												X			
6	12092003	FILTRO CO-400	CO-400 FILTER	1															
7	12009986	ABRAZADERA 32-50L	32-50L CLAMP	2															
8	12104085	JUNTA TORICA ALIVIADERO	SPILLWAY O-RING	1															
9	12120615	ALIVIADERO CO-400 B	CO-400 B SPILLWAY	1															
10	12023666	MANGUERA DESAGÜE	DRAINING PIPE	1												X			
11	12049666	ABRAZADERA ELASTICA 38,5-43	ELASTIC CLAMP 38,5-43	1															

N plano / Drawing N.	Firma / Signature	Fecha / Date	Aparato / Appliance	ACARADO / RINSING PART	Lamina / Sheet	Fagor Industrial S. Coop. FAGOR Oparte
C-3333	Iban R	2014-12	CO-352-402 COLD GLASSWASHER		5	

ITEM MARCADO EN COLOR = REPUESTO RECOMENDADO
 COLOURED ITEM = RECOMMENDED SPARE PART

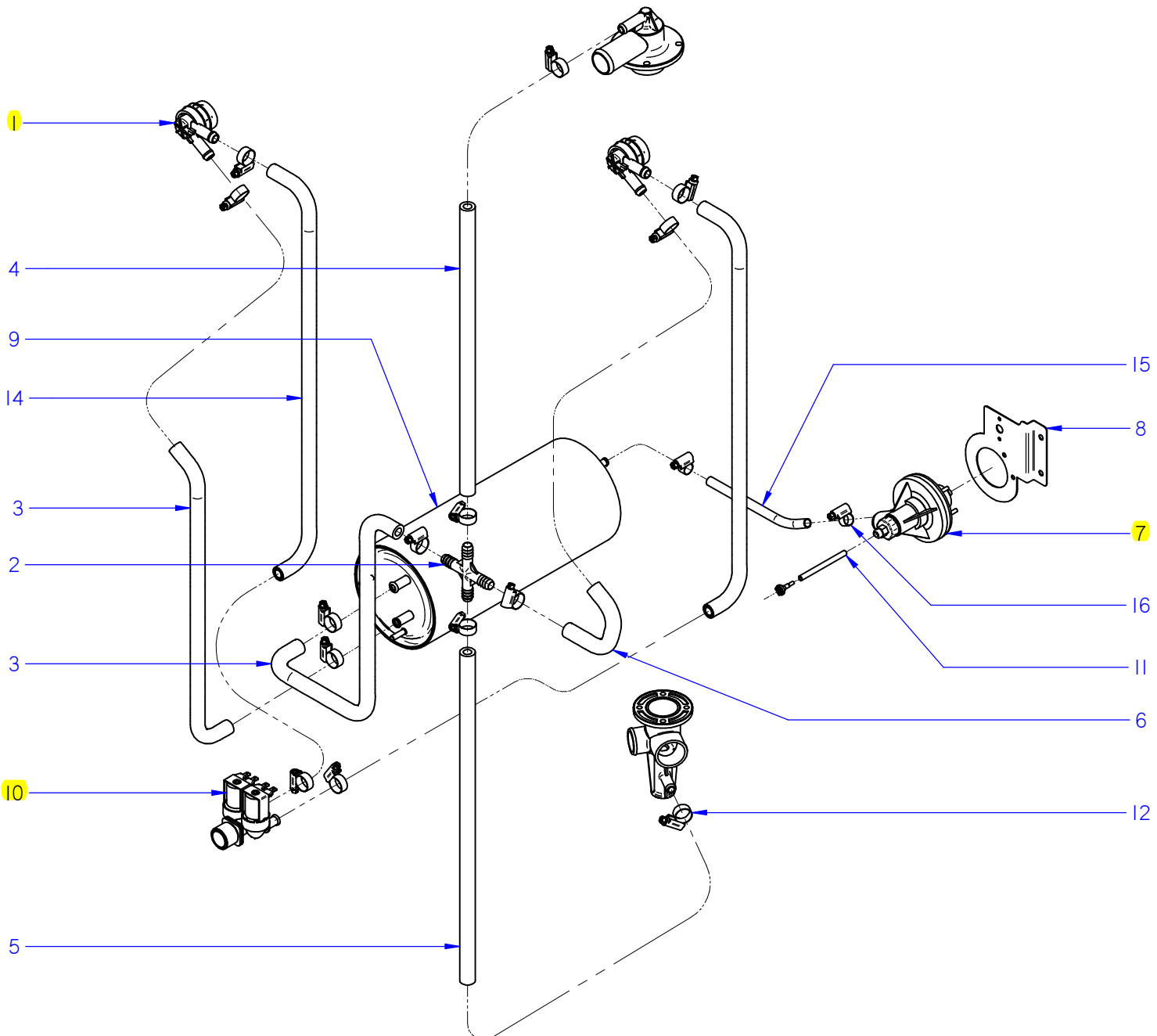

ITEM	REFERENCIA REFERENCE	DENOMINACIÓN	DENOMINATION	CO-352 COLD	CO-402 COLD							RECOMMENDED	ELIMINADO ELIMINATED	INTRODUCIDO INTRODUCED	NOTAS / NOTES
1	12024568	VALVULA ANTIRRETORNO	NON-RETURN VALVE	2	2							X			
2	12024192	RACORD EN CRUZ	CROSS FITTING	1	1										
3	12093329	CONDUCTO CALDERIN-RACORD	BOILER-FITTING PIPE	2	-										
3	12093402	CONDUCTO CALDERIN-RACORD	BOILER-FITTING PIPE	-	2										
4	11000083	TUBO GOMA NEGRA D 17x10	BLACK RUBBER PIPE D 17x10	1	1										
5	11000083	TUBO GOMA NEGRA D 17x10	BLACK RUBBER PIPE D 17x10	1	1										
6	11000083	TUBO GOMA NEGRA D 17x10	BLACK RUBBER PIPE D 17x10	1	1										
7	12045206	DOSIFICADOR ABRILL. AQUA	AQUA RINSE-AID DISPENSER	1	1							X			
8	12046466	SOPORTE TERMOSTATOS	THERMOSTATS SUPPORT	1	1										
9	12049602	CALDERIN CO-400	BOILER CO-400	1	1										
10	12110531	ELECTROVALVULA DOBLE	DOUBLE ELECTROVALVE	1	1							X			
11	12024139	CONDUCTO ASPIRACIÓN AZKOY CO	AZKOY SUCTION PIPE	1	1										
12	12010036	ABRAZADERA 12-20	12-20 CLAMP	14	14										
14	12093330	CONDUCTO EV-ANTIRRETORNO	EV-NON-RETURN PIPE	2	-										
14	12093403	CONDUCTO EV-ANTIRRETORNO	EV-NON-RETURN PIPE	-	2										
15	11000070	TUBO GOMA NEGRO D 10,5*5	BLACK RUBBER PIPE D 10,5*5	1	1										
16	12010047	ABRAZADERA 8-14L	8-14L CLAMP	2	2										

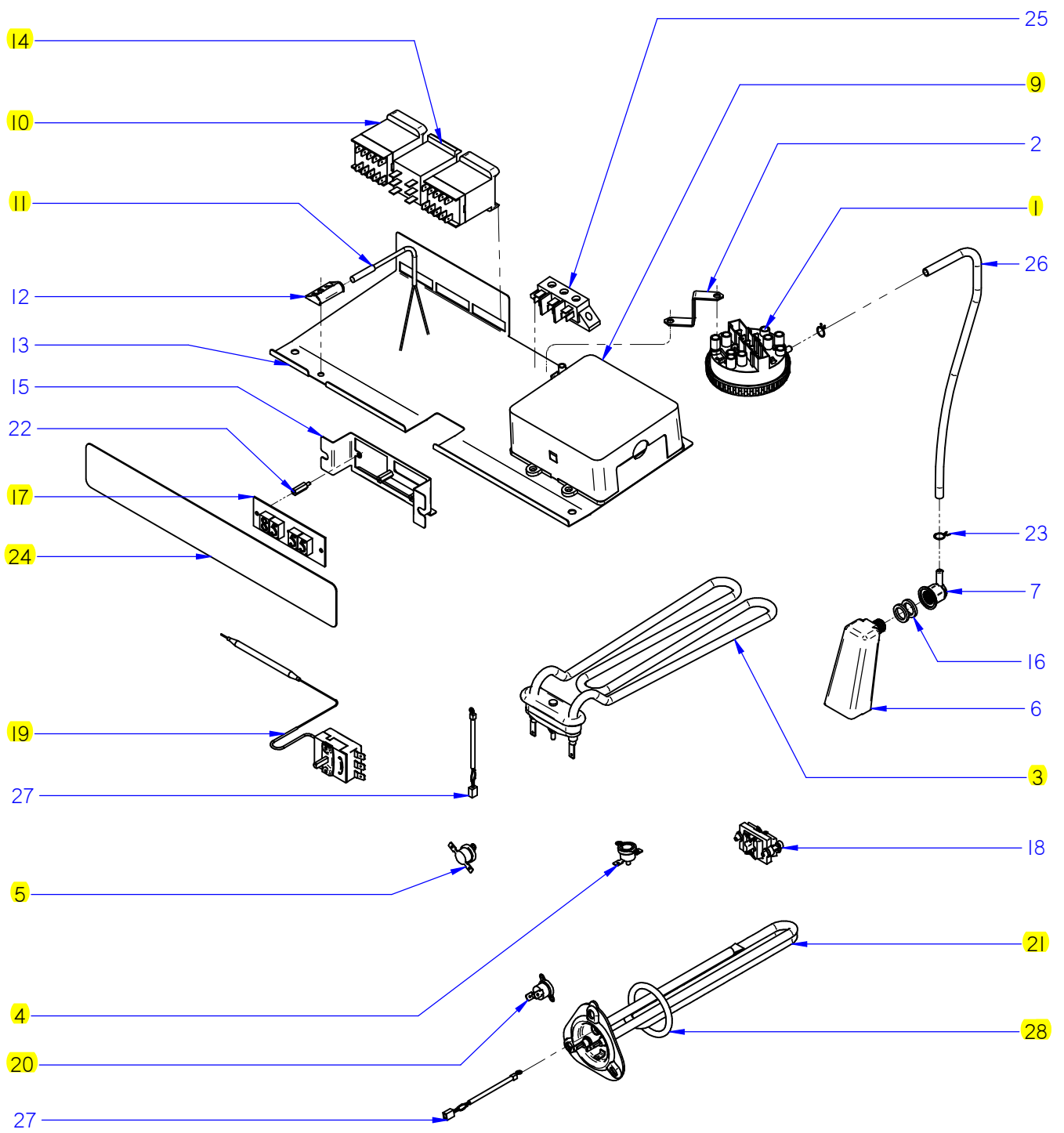

ITEM MARCADO EN COLOR = REPUESTO RECOMENDADO
 COLOURED ITEM = RECOMMENDED SPARE PART

N plano / Drawing N.	Firma / Signature	Fecha / Date	Aparato / Appliance	PARTE FUNCIONAL LAVADO / WASHING FUNCTIONAL PART	Lamina / Sheet	Fagor Industrial S.Coop. FAGOR
C-3335	Iban R.	03-2015	CO-352-402	COLD GLASSWASHER	7	Oñate

ZONA / ZONE	CONJUNTO ELECTRICO / ELECTRICAL PART	LÁMINA / DRAWING	C-3335	FAGOR 
-------------	--------------------------------------	------------------	--------	---

ITEM	REFERENCIA REFERENCE	DENOMINACIÓN	DENOMINATION	CO-352 COLD	CO-402 COLD						RECOMMENDED	ELIMINADO ELIMINATED	INTRODUCIDO INTRODUCED	NOTAS / NOTES
1	12023803	PRESOSTATO SIMPLE	SIMPLE PRESSURE SWITCH	1	1						X			
1	12024981	PRESOSTATO DOBLE	DOUBLE PRESSURE SWITCH	1	1						X			MODELOS B MODELS ONLY
2	12023163	SOPORTE PRESOSTATO	PRESSURE SWITCH SUPPORT	1	1									
3	12090524	RESISTENCIA TANQUE 400 2 KW	TUB RESISTOR 400 2KW	1	1						X			
4	12090518	TERM. SEG. 261B NC 95°C	SAFETY THER. 261B 95°C	1	1						X			
5	12090526	TERM. SEG. 261 NC 56°C	SAFETY THER. 261 56°C	1	1						X			
6	12090549	CAMARA PRESOSTATO CO-400	PRESSURE CHAMBER CO-400	1	1						X			
7	12091147	RACOR PRESOSTATO CO-400	PRESSURE SWITCH FITTING CO-400	1	1									
9	12008750	CONTROL TARJETA 5 RELES	5 RELAY COTROL CARD	1	1						X			
10	12024011	CONTACTOR 230 V. 50-60 HZ	230 V. 50-60 HZ CONTACTOR	2	2						X			
11	12024477	INTERRUPTOR MAGNETICO	MAGNETIC SWITCH	1	1						X			
12	12024066	AMARRE INTERRUPTOR MAGNETICO	MAGNETIC SWITCH'S SUPPORT	1	1									
13	12116648	SOP. COMPONENTES ELECTRICOS	ELECTRIC COMPONENTS SUPPORT	1										
13	12113866	SOP. COMPONENTES ELECTRICOS	ELECTRIC COMPONENTS SUPPORT		1									
14	12023706	RELE 230V. 16A 50-60 HZ	230V. 16A 50-60 HZ RELAY	1	1						X			
15	12022219	SOPORTE VISUALIZADOR	DISPLAY SUPPORT	1	1									
16	12009873	JUNTA CAMARA PRESOSTATO	PRESSURE CHAMBER SEAL	2	2									
17	12024028	VISUALIZADOR 12V 4 DIGITOS 7 SEG.	12V 4 DIGITS 7 SEGMENTS DISPLAY	1	1						X			
18	12024230	RETENEDOR DE CABLE	CABLE RETAINER	1	1									
19	12046152	TERMOSTAT. CALDERIN 85°C TECASA	BOILER THERMOSTAT 85°C TECASA	1	1						X			
20	12096597	TERM_SEG_261B_110°C_FAST_90	SAFETY THER. 261B_110°C_FAST_90	1	1						X			
21	12093151	RESISTENCIA CALDERIN 2,4KW	BOILER'S RESISTOR 2,4KW	1							X			
21	12093124	RESISTENCIA CALDERIN 2,8KW	BOILER'S RESISTOR 2,8KW		1						X			
22	12025260	DISTANCIADOR M3	M3 SPACER	3	3									
23	12023707	BRIDA ELASTICA TUBO	ELASTIC CLAMP FOR PIPES	2	2									
24	12115249	EMBELLECEDOR CO-352-402	CO-352-402 STICKER	1	1						X			
25	12024382	REGLETA 40A 3VIA 5MM	CONNECTION STRIP 40A 3WAY 5MM	1	1									
26	11000066	TUBO GOMA NEGRO D 8*4	BLACK RUBBER PIPE D 8*4	1	1									
27	12025036	CONJUNTO Sonda 64KΩ NTC	64KΩ NTC SENSOR COMPLETE	2	2									
28	12102062	JUNTA TÓRICA RESIS. TUBULAR EVO	EVO TUBULAR RESISTOR O-RING	1	1						X			

ITEM	REFERENCIA REFERENCE	DENOMINACIÓN	DENOMINATION	CO-352 COLD	CO-402 COLD							RECOMMENDED	ELIMINADO ELIMINATED	INTRODUCIDO INTRODUCED	NOTAS / NOTES
	12023746	CABLEADO ALIMENTACIÓN	POWER CORD	1	1										
	12025112	CABLEADO ALIMENTACIÓN UK	POWER CORD UK	1	1										
	12115668	CABLEADO PORTAMANDOS	CONTROL PANEL WIRING	1	1										
	12024183	CABLEADO TIERRAM.BOMBA	EARTH PUMP WIRING	1	1										
	12114337	INSTALACIÓN ELECTRICA	ELECTRICAL WIRING	1	1										

ZONA / ZONE	RECOMENDADOS / RECOMMENDED				LÁMINA / DRAWING				FAGOR 			
-------------	----------------------------	--	--	--	------------------	--	--	--	---	--	--	--

ITEM	REFERENCIA REFERENCE	DENOMINACIÓN	DENOMINATION	CO-352 COLD	CO-352 COLD D	CO-352 COLD B	CO-352 COLD B DD				RECOMMENDED	ELIMINADO ELIMINATED	INTRODUCIDO INTRODUCED	NOTAS / NOTES
4	12024346	CONDENSADOR 10MF	10MF CAPACITOR	1	1	1	1							C-3330
28	12024216	DOSIFIC. DGTE REGULABLE G300	REGUL. DETERG. DISPENSER G300	-	1	-	1							C-3330
24	12023429	BOMBA LAVADO 50/60HZ 260KW	WASHING PUMP 50/60HZ 260KW	1	1	1	1							C-3330
6	12024114	MANGUERA DESAGUE	DRAINING PIPE	1	1	-	-							C-3331
5	12094265	BOMBA DESAGÜE 1N 50/60Hz 38W	DRAINING PUMP 1N 50/60Hz 38W	-	-	1	1							C-3332
10	12023666	MANGUERA DESAGÜE	DRAINING PIPE	-	-	1	1							C-3332
1	12024568	VALVULA ANTIRRETORNO	NON-RETURN VALVE	2	2	2	2							C-3333
7	12045206	DOSIFICADOR ABRILL. AQUA	AQUA RINSE-AID DISPENSER	1	1	1	1							C-3333
10	12110531	ELECTROVALVULA DOBLE	DOUBLE ELECTROVALVE	1	1	1	1							C-3333
1	12023803	PRESOSTATO SIMPLE	SIMPLE PRESSURE SWITCH	1	1	-	1							C-3335
1	12024981	PRESOSTATO DOBLE	DOUBLE PRESSURE SWITCH	-	-	1	-							C-3335
3	12090524	RESISTENCIA TANQUE 400 2 KW	TUB RESISTOR 400 2KW	1	1	1	1							C-3335
4	12090518	TERM. SEG. 261B NC 95°C	SAFETY THER. 261B 95°C	1	1	1	1							C-3335
5	12090526	TERM. SEG. 261 NC 56°C	SAFETY THER. 261 56°C	1	1	1	1							C-3335
6	12090549	CAMARA PRESOSTATO CO-400	PRESSURE CHAMBER CO-400	1	1	1	1							C-3335
9	12008750	CONTROL TARJETA 5 RELES	5 RELAY COTROL CARD	1	1	1	1							C-3335
10	12024011	CONTACTOR 230 V. 50-60 HZ	230 V. 50-60 HZ CONTACTOR	2	2	2	2							C-3335
11	12024477	INTERRUPTOR MAGNETICO	MAGNETIC SWITCH	1	1	1	1							C-3335
14	12023706	RELE 230V. 16A 50-60 HZ	230V. 16A 50-60 HZ RELAY	1	1	1	1							C-3335
17	12024028	VISUALIZADOR 12V 4 DIGITOS 7 SEG.	12V 4 DIGITS 7 SEGMENTS DISPLAY	1	1	1	1							C-3335
19	12046152	TERMOSTAT. CALDERIN 85°C TECASA	BOILER THERMOSTAT 85°C TECASA	1	1	1	1							C-3335
20	12096597	TERM_SEG_261B_110°C_FAST_90	SAFETY THER. 261B_110°C_FAST_90	1	1	1	1							C-3335
21	12093151	RESISTENCIA CALDERIN 2,4KW	BOILER'S RESISTOR 2,4KW	1	1	1	1							C-3335
24	12115249	EMBELLECEDOR CO-352-402	CO-352-402 STICKER	1	1	1	1							C-3335
28	12102062	JUNTA TÓRICA RESIS. TUBULAR EVO	EVO TUBULAR RESISTOR O-RING	1	1	1	1							C-3335

ZONA / ZONE	RECOMENDADOS / RECOMMENDED	LÁMINA / DRAWING	FAGOR 
-------------	----------------------------	------------------	---

ITEM	REFERENCIA REFERENCE	DENOMINACIÓN	DENOMINATION	CO-402 COLD	CO-402 COLD DI	CO-402 COLD B	CO-402 COLD B DD				RECOMMENDED	ELIMINADO ELIMINATED	INTRODUCIDO INTRODUCED	NOTAS / NOTES
4	12024346	CONDENSADOR 10MF	10MF CAPACITOR	1	1	1	1							C-3330
28	12024216	DOSIFIC. DGTE REGULABLE G300	REGUL. DETERG. DISPENSER G300	-	1	-	1							C-3330
24	12023429	BOMBA LAVADO 50/60HZ 260KW	WASHING PUMP 50/60HZ 260KW	1	1	1	1							C-3330
6	12024114	MANGUERA DESAGUE	DRAINING PIPE	1	1	-	-							C-3331
5	12094265	BOMBA DESAGÜE 1N 50/60Hz 38W	DRAINING PUMP 1N 50/60Hz 38W	-	-	1	1							C-3332
10	12023666	MANGUERA DESAGÜE	DRAINING PIPE	-	-	1	1							C-3332
1	12024568	VALVULA ANTIRRETORNO	NON-RETURN VALVE	2	2	2	2							C-3333
7	12045206	DOSIFICADOR ABRILL. AQUA	AQUA RINSE-AID DISPENSER	1	1	1	1							C-3333
10	12110531	ELECTROVALVULA DOBLE	DOUBLE ELECTROVALVE	1	1	1	1							C-3333
1	12023803	PRESOSTATO SIMPLE	SIMPLE PRESSURE SWITCH	1	1	-	1							C-3335
1	12024981	PRESOSTATO DOBLE	DOUBLE PRESSURE SWITCH	-	-	1	-							C-3335
3	12090524	RESISTENCIA TANQUE 400 2 KW	TUB RESISTOR 400 2KW	1	1	1	1							C-3335
4	12090518	TERM. SEG. 261B NC 95°C	SAFETY THER. 261B 95°C	1	1	1	1							C-3335
5	12090526	TERM. SEG. 261 NC 56°C	SAFETY THER. 261 56°C	1	1	1	1							C-3335
6	12090549	CAMARA PRESOSTATO CO-400	PRESSURE CHAMBER CO-400	1	1	1	1							C-3335
9	12008750	CONTROL TARJETA 5 RELES	5 RELAY COTROL CARD	1	1	1	1							C-3335
10	12024011	CONTACTOR 230 V. 50-60 HZ	230 V. 50-60 HZ CONTACTOR	2	2	2	2							C-3335
11	12024477	INTERRUPTOR MAGNETICO	MAGNETIC SWITCH	1	1	1	1							C-3335
14	12023706	RELE 230V. 16A 50-60 HZ	230V. 16A 50-60 HZ RELAY	1	1	1	1							C-3335
17	12024028	VISUALIZADOR 12V 4 DIGITOS 7 SEG.	12V 4 DIGITS 7 SEGMENTS DISPLAY	1	1	1	1							C-3335
19	12046152	TERMOSTAT. CALDERIN 85°C TECASA	BOILER THERMOSTAT 85°C TECASA	1	1	1	1							C-3335
20	12096597	TERM_SEG_261B_110°C_FAST_90	SAFETY THER. 261B_110°C_FAST_90	1	1	1	1							C-3335
21	12093124	RESISTENCIA CALDERIN 2,8KW	BOILER'S RESISTOR 2,8KW	1	1	1	1							C-3335
24	12115249	EMBELLECEDOR CO-352-402	CO-352-402 STICKER	1	1	1	1							C-3335
28	12102062	JUNTA TÓRICA RESIS. TUBULAR EVO	EVO TUBULAR RESISTOR O-RING	1	1	1	1							C-3335

CO 402 W

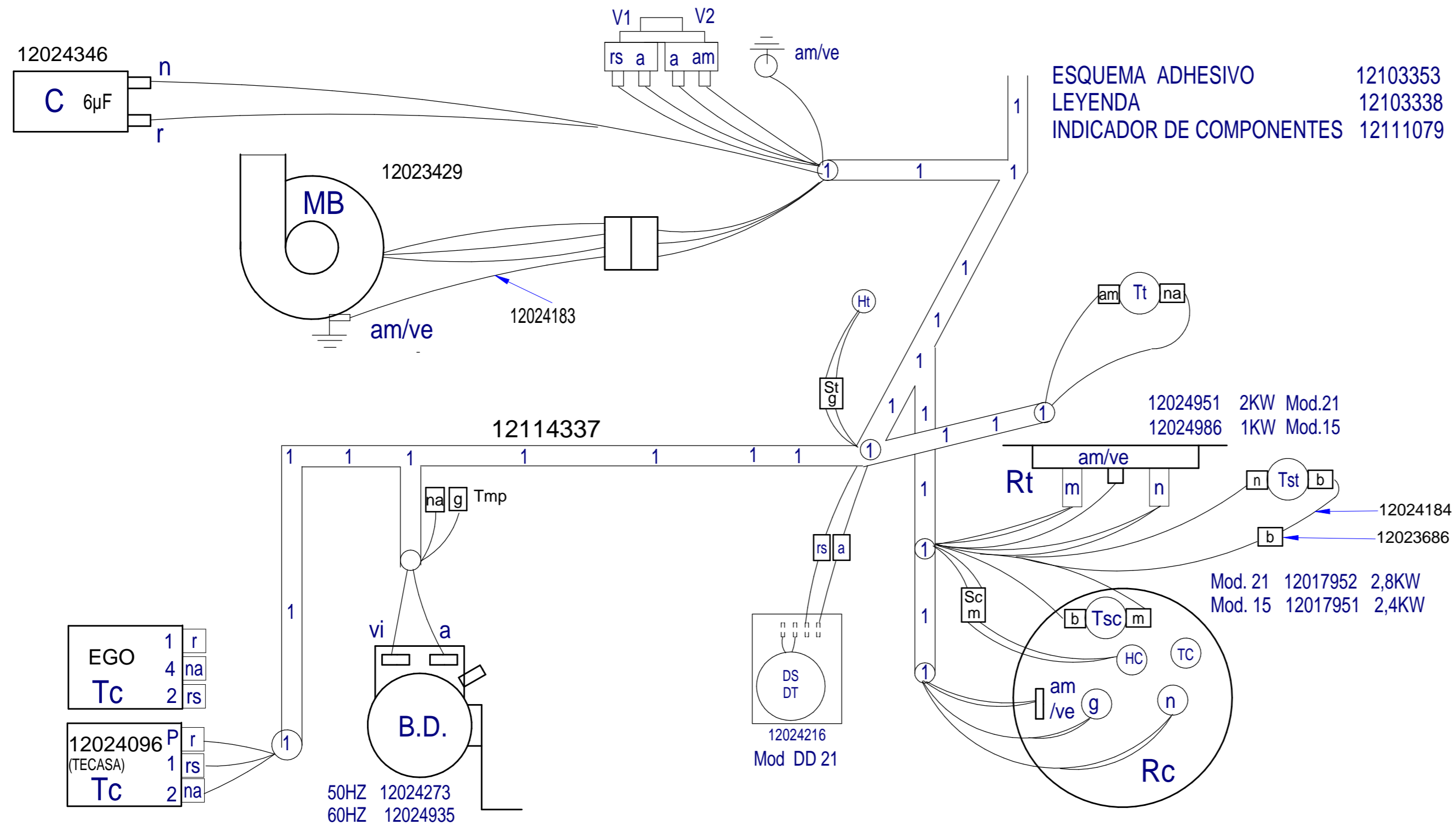
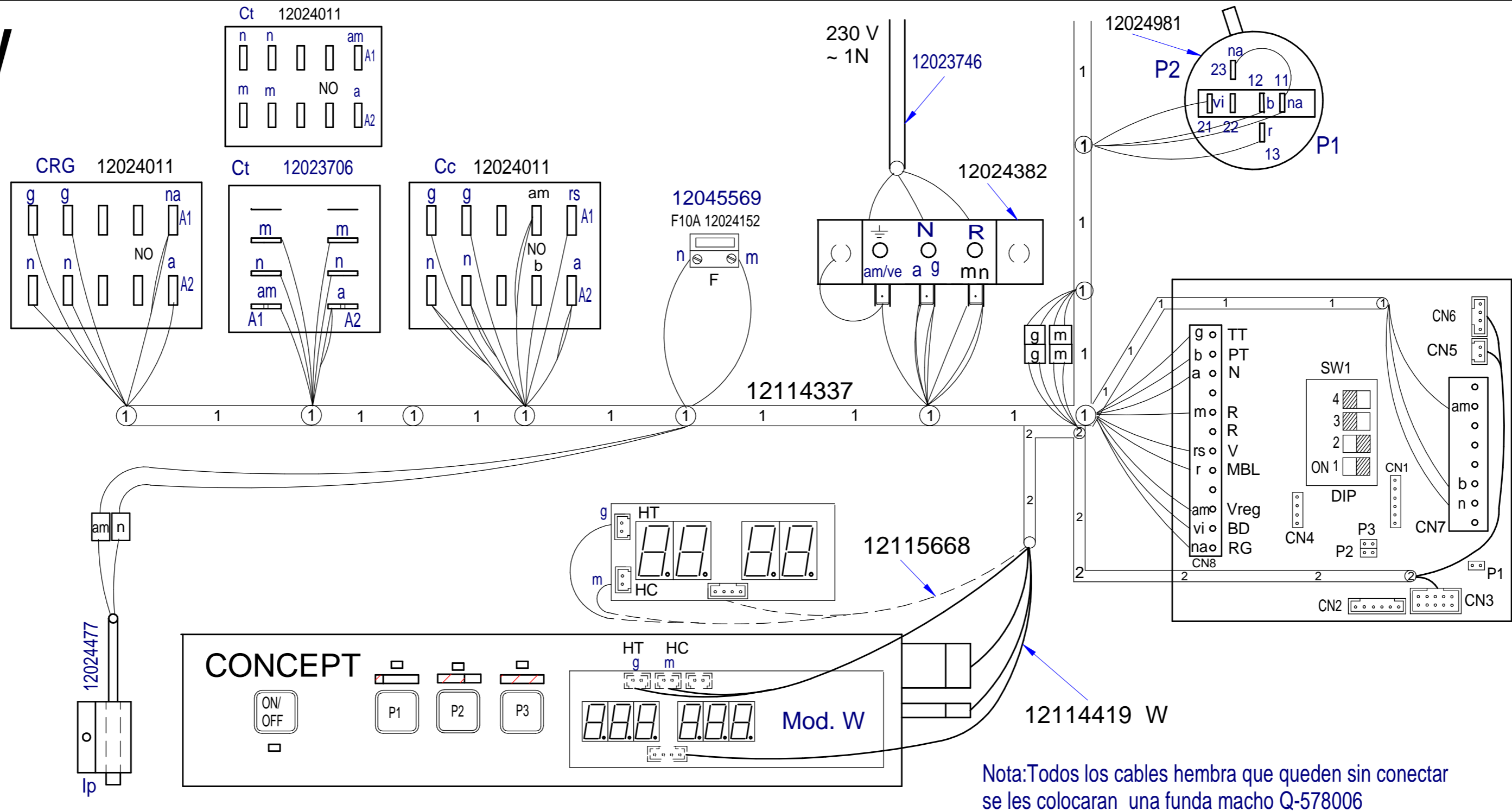

Plano Montaje CO 402 W (21 W)		12114490																																																																																	
Nº	TITLE	QTY	CODE																																																																																
GENERAL TOLERANCES: ISO 2768-1 Very Coarse																																																																																			
<table border="1"> <tr> <th>LINEAL</th> <th>Fine</th> <th>Medium</th> <th>Coarse</th> <th>Very Coarse</th> <th>ANGULAR</th> <th>Fine</th> <th>Medium</th> <th>Coarse</th> <th>Very Coarse</th> </tr> <tr> <td><2mm</td> <td>±0.05</td> <td>±0.10</td> <td>±0.15</td> <td></td> <td><10mm</td> <td>±1°</td> <td>±1°30'</td> <td>±2°</td> <td>±3°</td> </tr> <tr> <td>2-5mm</td> <td>±0.05</td> <td>±0.10</td> <td>±0.20</td> <td></td> <td>10-50mm</td> <td>±30'</td> <td>±1°</td> <td>±2°</td> <td></td> </tr> <tr> <td>5-30mm</td> <td>±0.10</td> <td>±0.20</td> <td>±0.50</td> <td></td> <td>50-120mm</td> <td>±20'</td> <td>±30'</td> <td>±1°</td> <td></td> </tr> <tr> <td>30-120mm</td> <td>±0.15</td> <td>±0.30</td> <td>±0.80</td> <td></td> <td>120-400mm</td> <td>±10'</td> <td>±15'</td> <td>±30'</td> <td></td> </tr> <tr> <td>120-400mm</td> <td>±0.20</td> <td>±0.50</td> <td>±1.20</td> <td></td> <td>>400mm</td> <td>±5'</td> <td>±10'</td> <td>±20'</td> <td></td> </tr> <tr> <td>420-1000mm</td> <td>±0.30</td> <td>±0.80</td> <td>±2.00</td> <td></td> <td colspan="5">GENERAL TOLERANCE FOR FORM AND POSITION: ISO 2768-2</td> </tr> <tr> <td>1000-2000mm</td> <td>±0.50</td> <td>±1.20</td> <td>±3.00</td> <td></td> <td colspan="5">LAVAVAJILLAS</td> </tr> </table>				LINEAL	Fine	Medium	Coarse	Very Coarse	ANGULAR	Fine	Medium	Coarse	Very Coarse	<2mm	±0.05	±0.10	±0.15		<10mm	±1°	±1°30'	±2°	±3°	2-5mm	±0.05	±0.10	±0.20		10-50mm	±30'	±1°	±2°		5-30mm	±0.10	±0.20	±0.50		50-120mm	±20'	±30'	±1°		30-120mm	±0.15	±0.30	±0.80		120-400mm	±10'	±15'	±30'		120-400mm	±0.20	±0.50	±1.20		>400mm	±5'	±10'	±20'		420-1000mm	±0.30	±0.80	±2.00		GENERAL TOLERANCE FOR FORM AND POSITION: ISO 2768-2					1000-2000mm	±0.50	±1.20	±3.00		LAVAVAJILLAS				
LINEAL	Fine	Medium	Coarse	Very Coarse	ANGULAR	Fine	Medium	Coarse	Very Coarse																																																																										
<2mm	±0.05	±0.10	±0.15		<10mm	±1°	±1°30'	±2°	±3°																																																																										
2-5mm	±0.05	±0.10	±0.20		10-50mm	±30'	±1°	±2°																																																																											
5-30mm	±0.10	±0.20	±0.50		50-120mm	±20'	±30'	±1°																																																																											
30-120mm	±0.15	±0.30	±0.80		120-400mm	±10'	±15'	±30'																																																																											
120-400mm	±0.20	±0.50	±1.20		>400mm	±5'	±10'	±20'																																																																											
420-1000mm	±0.30	±0.80	±2.00		GENERAL TOLERANCE FOR FORM AND POSITION: ISO 2768-2																																																																														
1000-2000mm	±0.50	±1.20	±3.00		LAVAVAJILLAS																																																																														
DESIGNED BY: M.Maíllo		VALIDATED BY: A.G.																																																																																	
DATE: 12.06.2014		SHEET: 1 / 1																																																																																	
SCALE: 1:1		ISSUE DATE:																																																																																	

12114490

REVISION

PROPOSED BY: - ISSUE DATE:

CO-502 W, COP-504 W

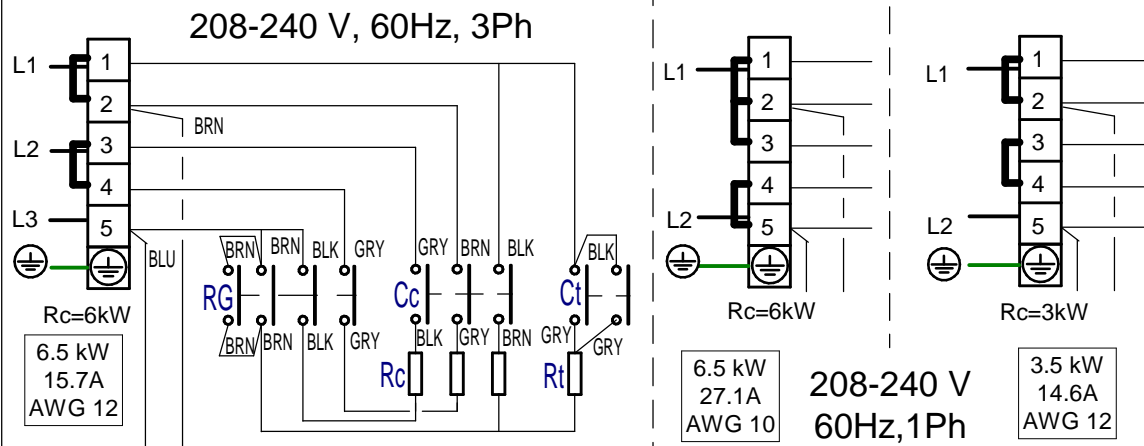

CO-142W, COP-174 W

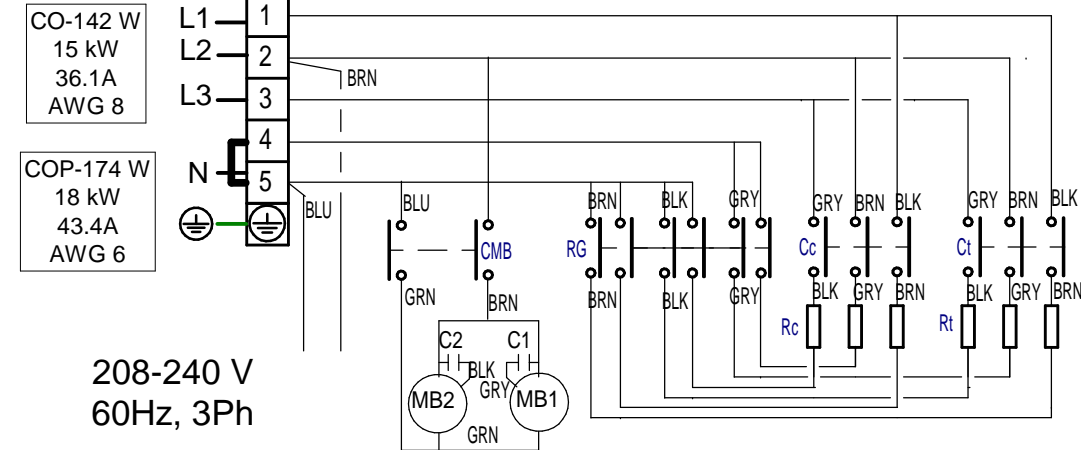

CO-402 W

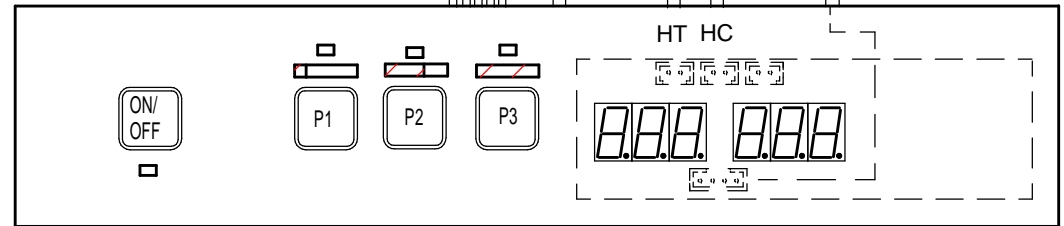
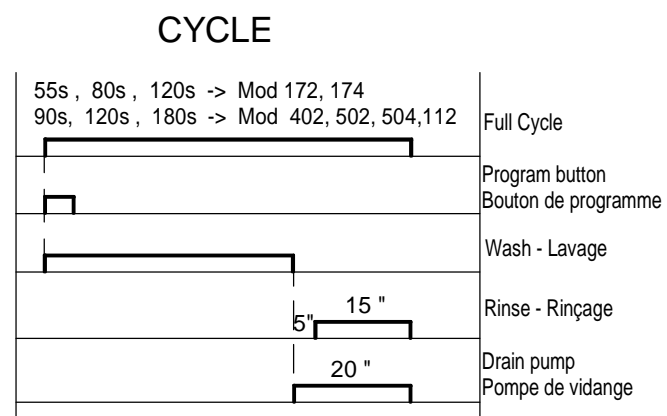
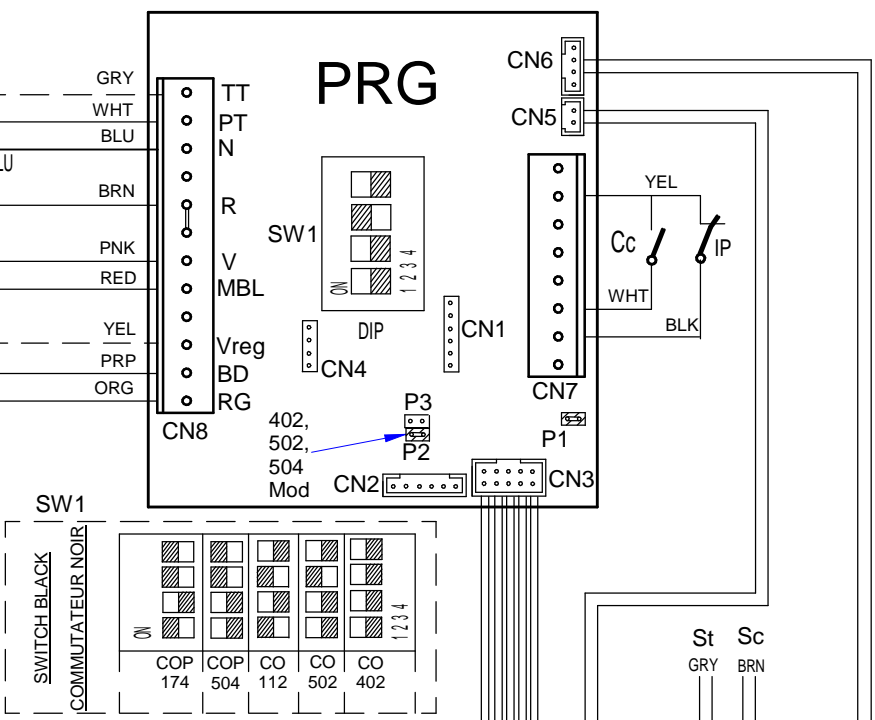
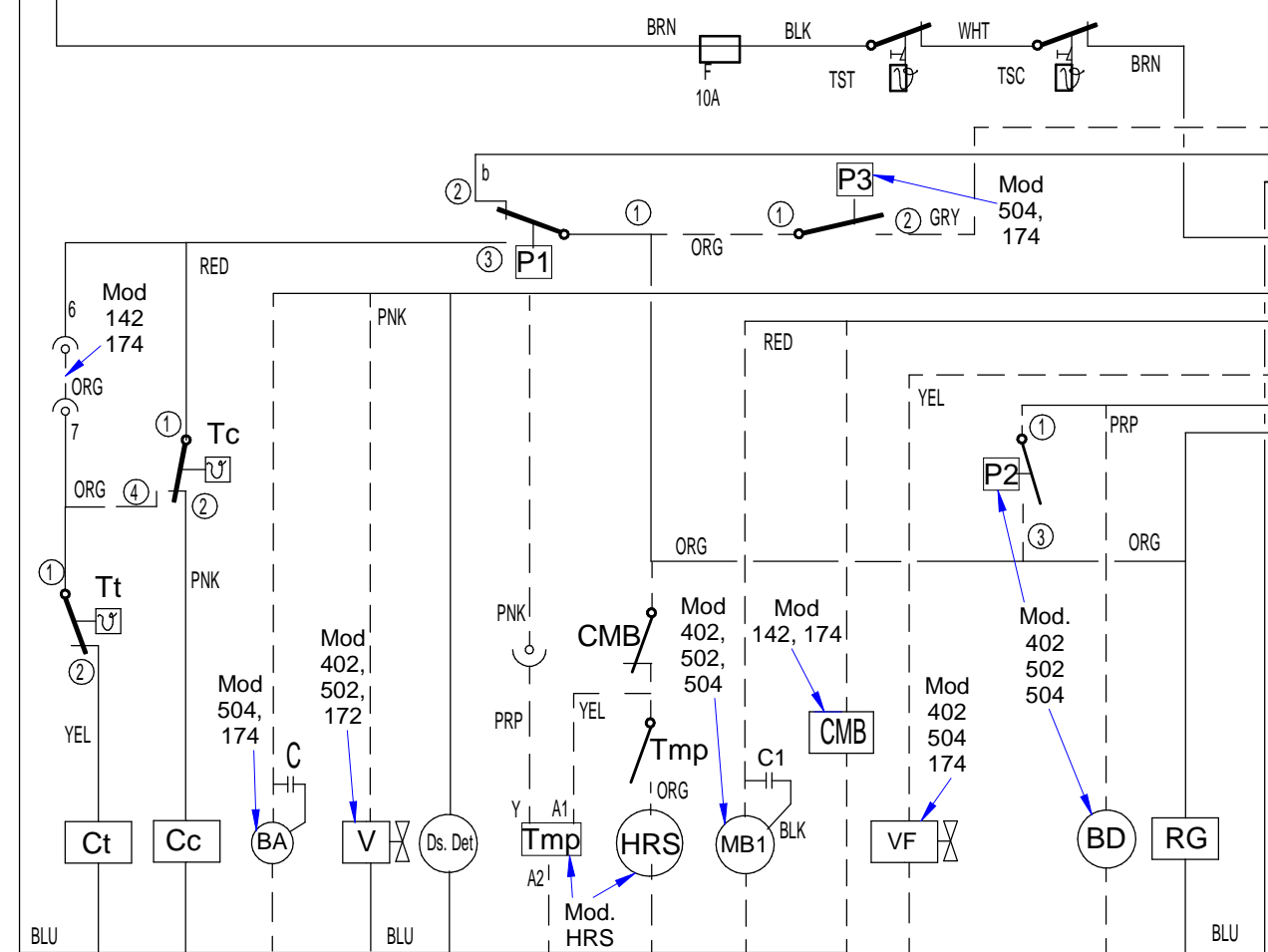
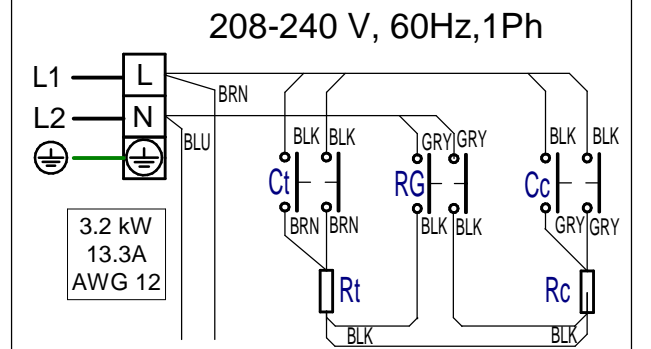

Ref. 12114451

- Esquema Teorico CO XX2 W, COP XX4 W -		12114451																																																																																	
Nº	TITLE	QTY	CODE																																																																																
GENERAL TOLERANCES: ISO 2768-1 Very Coarse		MATERIAL																																																																																	
<table border="1"> <tr> <th>LINEAR</th> <th>Fine</th> <th>Medium</th> <th>Coarse</th> <th>Very Coarse</th> <th>ANGULAR</th> <th>Fine</th> <th>Medium</th> <th>Coarse</th> <th>Very Coarse</th> </tr> <tr> <td><3mm</td> <td>±0.05</td> <td>±0.10</td> <td>±0.15</td> <td>±0.20</td> <td><10mm</td> <td>±1°</td> <td>±1°30'</td> <td>±2°</td> <td>±3°</td> </tr> <tr> <td>3-6mm</td> <td>±0.05</td> <td>±0.10</td> <td>±0.20</td> <td>±0.50</td> <td>10-50mm</td> <td>±30'</td> <td>±1°</td> <td>±2°</td> <td>±1°</td> </tr> <tr> <td>6-30mm</td> <td>±0.10</td> <td>±0.20</td> <td>±0.50</td> <td>±1.20</td> <td>50-120mm</td> <td>±20'</td> <td>±30'</td> <td>±1°</td> <td>±1°</td> </tr> <tr> <td>30-120mm</td> <td>±0.15</td> <td>±0.30</td> <td>±0.80</td> <td>±2.00</td> <td>120-400mm</td> <td>±10'</td> <td>±15'</td> <td>±30'</td> <td>±1°</td> </tr> <tr> <td>120-400mm</td> <td>±0.20</td> <td>±0.50</td> <td>±1.20</td> <td>±2.00</td> <td>>400mm</td> <td>±5'</td> <td>±10'</td> <td>±20'</td> <td>±1°</td> </tr> <tr> <td>400-1000mm</td> <td>±0.30</td> <td>±0.80</td> <td>±2.00</td> <td>±3.00</td> <td colspan="5"></td> </tr> <tr> <td>1000-2000mm</td> <td>±0.50</td> <td>±1.20</td> <td>±3.00</td> <td></td> <td colspan="5"></td> </tr> </table>		LINEAR	Fine	Medium	Coarse	Very Coarse	ANGULAR	Fine	Medium	Coarse	Very Coarse	<3mm	±0.05	±0.10	±0.15	±0.20	<10mm	±1°	±1°30'	±2°	±3°	3-6mm	±0.05	±0.10	±0.20	±0.50	10-50mm	±30'	±1°	±2°	±1°	6-30mm	±0.10	±0.20	±0.50	±1.20	50-120mm	±20'	±30'	±1°	±1°	30-120mm	±0.15	±0.30	±0.80	±2.00	120-400mm	±10'	±15'	±30'	±1°	120-400mm	±0.20	±0.50	±1.20	±2.00	>400mm	±5'	±10'	±20'	±1°	400-1000mm	±0.30	±0.80	±2.00	±3.00						1000-2000mm	±0.50	±1.20	±3.00								
LINEAR	Fine	Medium	Coarse	Very Coarse	ANGULAR	Fine	Medium	Coarse	Very Coarse																																																																										
<3mm	±0.05	±0.10	±0.15	±0.20	<10mm	±1°	±1°30'	±2°	±3°																																																																										
3-6mm	±0.05	±0.10	±0.20	±0.50	10-50mm	±30'	±1°	±2°	±1°																																																																										
6-30mm	±0.10	±0.20	±0.50	±1.20	50-120mm	±20'	±30'	±1°	±1°																																																																										
30-120mm	±0.15	±0.30	±0.80	±2.00	120-400mm	±10'	±15'	±30'	±1°																																																																										
120-400mm	±0.20	±0.50	±1.20	±2.00	>400mm	±5'	±10'	±20'	±1°																																																																										
400-1000mm	±0.30	±0.80	±2.00	±3.00																																																																															
1000-2000mm	±0.50	±1.20	±3.00																																																																																
LAVAVAJILLAS		DESIGNED BY	VALIDATED BY																																																																																
ISO 2768-2		M.Maillo	A.gallastegui																																																																																
12114451		DATE	11.06.2014																																																																																
REVISION		SHEET:	1 / 1																																																																																
PROPOSED BY: -		SCALE:	1:1																																																																																
		ISSUE DATE:																																																																																	

