

**Hornos Conveccion a Gas**  
**Fours Air ulsé à Gaz**  
**Gas Convection Ovens**  
**Gas-Konvektionsöfen**  
**Forni a Convezione a Gas**

**Modelos:**

**HCG-6/11**  
**HCG-10/11**  
**HCG-10/21**  
**HCG-2.10/11**

**VCG-6/11**  
**VCG-10/11**  
**VCG-10/21**  
**VCG-2.10/11**

*Mayo 2003 May*

**FAGOR**



**Fagor Industrial**

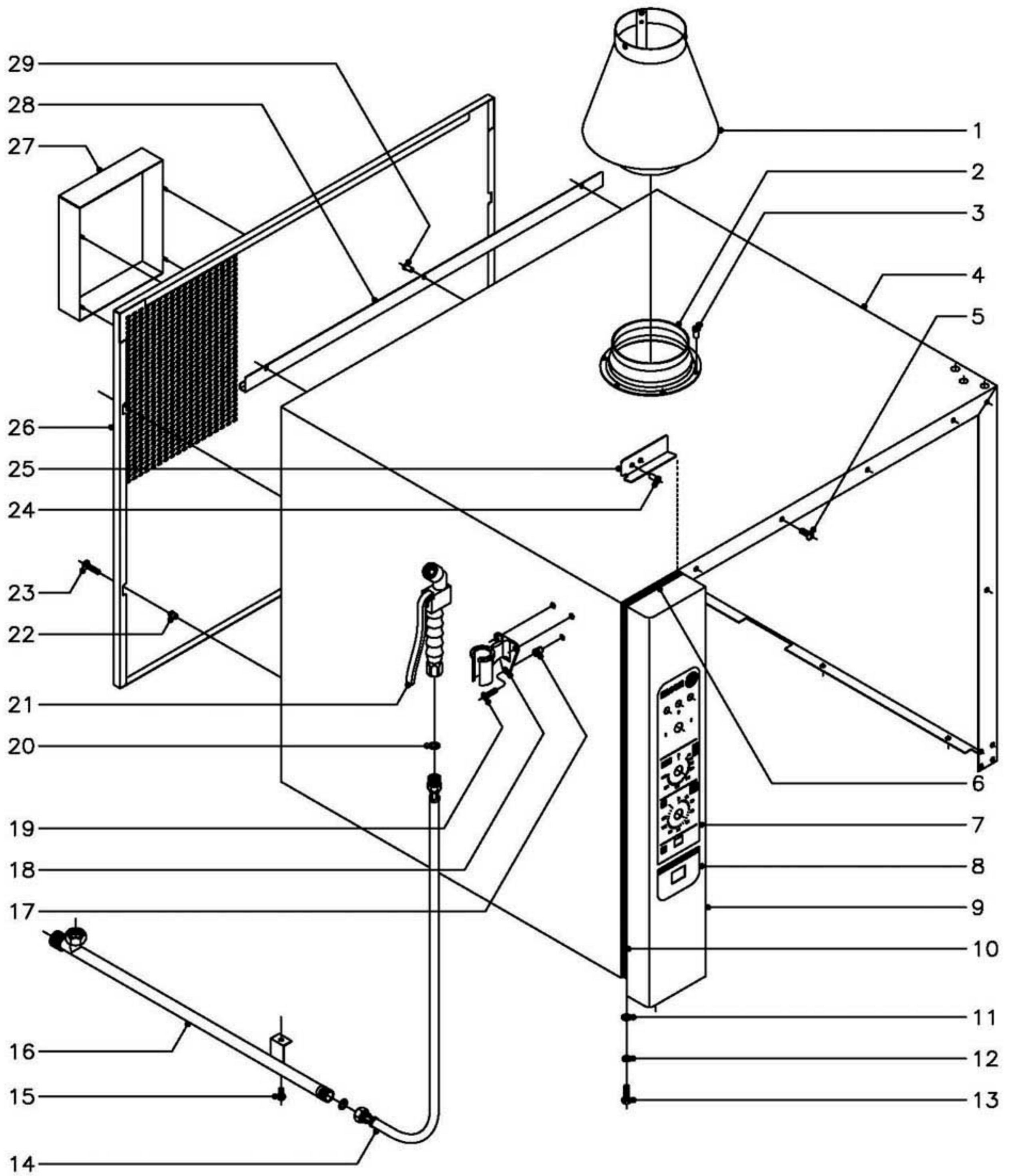

MOD.

HORNOS A GAS HCG

ZONA

MUEBLE



PLANO

C-1339

ITEM	CODIGO	DENOMINACION	TEXTO	HCG-6/11	HCG-10/11	HCG-10/21	HCG-2-10/11							NOTAS
1	R272612	Chimenea		1	1	1								
	R292646	Conducto humos		1	1	1								
	R272614	Soporte chimenea		3	3	3								
	Q412002	Remache tubular Ø 4x7,5		9	9	9								
2	R292645	Guia chimenea		1	1	1								
3	Q412000	Remache tubular Ø 4x8		6	6	6								
4	T082805	Cuerpo exterior de horno		1	-	-								
4	T012806	Cuerpo exterior de horno		-	1	-								
4	T022801	Cuerpo exterior de horno		-	-	1								
5	Q152017	Tornillo amarre M-6x13		5	6	6								
6	3715400	Junta panel portamandos L=130		1	1	1								
7	T013006	Serigrafia superior		1	1	1								
8	R723008	Serigrafia inferior		1	1	1								
9	T082810	Panel portamandos		1	-	-								
9	T012809	Panel portamandos		-	1	1								
10	3715400	Junta panel portamandos L=530		2	-	-								
10	3715400	Junta panel portamandos L=770		-	2	2								
11	Q232040	Arandela plana A-6		8	8	8								
12	Q262040	Arandela muelle A-6		8	8	8								
13	Q012042	Tornillo exagonal M-6x15		8	8	8								
14	R095006	Flexible de ducha		1	1	1								Opcional bajo pedido
15	Q012042	Tornillo exagonal M-6x15		1	1	1								Opcional bajo pedido
16	R675002	Suplemento ducha		1	1	-								Opcional bajo pedido
16	R685003	Suplemento ducha		-	-	1								Opcional bajo pedido
17	Q221342	Remache exagonal M-4		3	3	3								Opcional bajo pedido
18	R095007	Soporte de ducha		1	1	1								Opcional bajo pedido
19	Q042022	Tornillo avellanado M-4x15		3	3	3								Opcional bajo pedido
20	-	Arandela junta (con cuerpo ducha)		2	2	2								Opcional bajo pedido
21	R095005	Cuerpo de ducha		1	1	1								Opcional bajo pedido

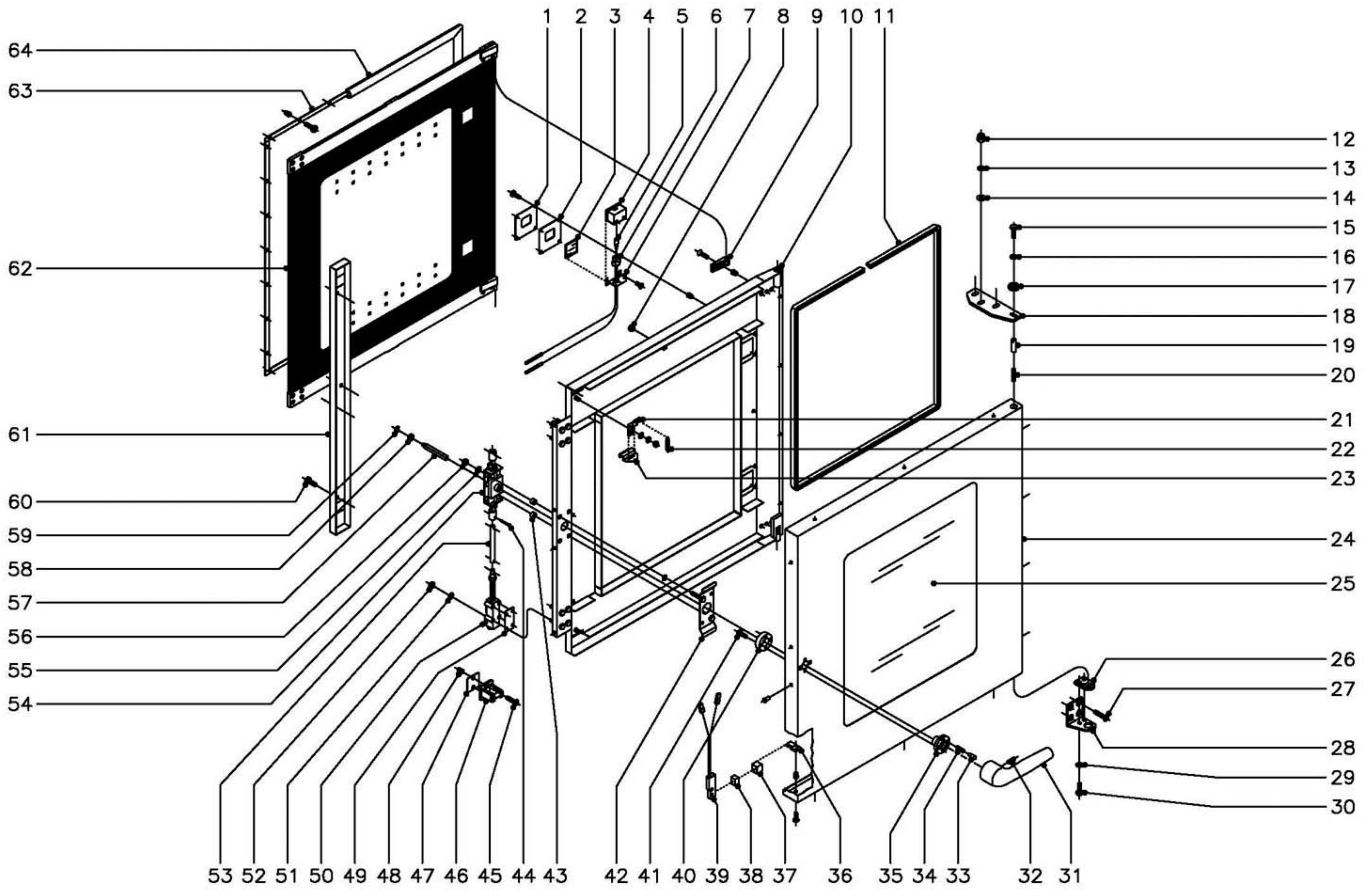
ITEM	CODIGO	DENOMINACION	TEXTO	HCG-6/11	HCG-10/11	HCG-10/21 HCG-2-10/11							NOTAS
22	Q221342	Remache exagonal M-5		4	4	4							
23	Q152038	Tornillo amarre M-5x30		4	4	4							
24	Q412002	Remache tubular Ø 4x7,5		2	2	2							
25	R662811	Fijacion portamandos		1	1	1							
26	T072903	Panel posterior exterior		1	-	-							
26	R722909	Panel posterior exterior		-	1	-							
26	R732902	Panel posterior exterior		-	-	1							
27	T082808	Tapa de separacion		1	1	1							
28	R672811	Canaleta recogeaguas		1	1	-							
28	R682806	Canaleta recogeaguas		-	-	1							
29	Q412002	Remache tubular Ø 4x7,5		3	3	3							



N plano C-1340	Firma 	Fecha 5-2003	Aparato PUERTA HORNOS A GAS HCG-6/11,10/11,10/21	Lamina 2	Fagor Industrial S.Coop. <b>FAGOR</b>  Ofote
-------------------	--	-----------------	--	-------------	--

MOD.	HORNOS A GAS HCG	ZONA	PUERTA	PLANO	C-1340
------	------------------	------	--------	-------	--------

ITEM	CODIGO	DENOMINACION	TEXTO	HCG-6/11	HCG-10/11	HCG-10/21	HCG-2-10/11							NOTAS
	1100002594	KIT Puerta completa 6/11		1	-	-								
	1100002595	KIT Puerta completa 10/11		-	1	-								
	1100002596	KIT Puerta completa 10/21		-	-	1								
1	R670608	Tapa cierre lampara		2	2	2								
	Q032021	Tornillo alomado M-4x10		8	8	8								
	Q222041	Remache exagonal M-4		8	8	8								
2	R670609	Junta cierre lampara		2	2	2								
3	R670618	Cristal de lampara		2	2	2								
4	R670610	Deflector de lampara		2	2	2								
5	R663013	Lampara 10 W. 12 V.		2	2	2								
6	R663058	Portalamparas		2	2	2								
7	R670611	Suplemento deflector		2	2	2								
	Q042031	Tornillo avellanado M-5x10		4	4	4								
8	R670617	Tope cristal interior		6	6	6								
9	R670615	Base de bisagra		2	2	2								
	Q042032	Tornillo avellanado M-5x15		2	2	2								
	Q222011	Remache exagonal M-5		2	2	2								
10	T080500	Contrapuerta completa 6/11		1	-	-								
10	T110500	Contrapuerta completa 10/11		-	1	-								
10	T120500	Contrapuerta completa 10/21		-	-	1								
11	3715200	Junta cristal L=1700		1	-	-								
11	3715200	Junta cristal L=2000		-	1	-								
11	3715200	Junta cristal L=2300		-	-	1								
12	Q212051	Tuerca sombrerete M-8		3	3	3								
13	Q242050	Arandela abanico A-8		3	3	3								
14	Q302025	Arandela plana Ø8,4xØ20x1,5		3	3	3								
15	Q012042	Tornillo exagonal M-6x15		1	1	1								
16	Q242040	Arandela abanico A-6		1	1	1								

MOD.

HORNOS A GAS HCG

ZONA

PUERTA

PLANO

C-1340

ITEM	CODIGO	DENOMINACION	TEXTO	HCG-6/11	HCG-10/11	HCG-10/21	HCG-2-10/11							NOTAS
17	R662807	Arandela amarre puerta		1	1	1								
18	T130500	Bisagra superior		1	1	1								
19	R660534	Eje superior		1	1	1								
20	Z850519	Resorte		1	1	1								
21	R670612	Base de pestillo		2	2	2								
	Q302022	Arandela plana Ø16xØ6x1,2		2	2	2								
	Q242040	Arandela abanico A-6		2	2	2								
	Q162040	Tuerca exagonal M-6		2	2	2								
22	R660605	Muelle tensor pestillo		2	2	2								
23	R670613	Pestillo sujecion cristal interior		2	2	2								
24	R660600	Panel puerta 6/11		1	-	-								
24	R670600	Panel puerta 10/11		-	1	-								
24	R680600	Panel puerta 10/21		-	-	1								
	Q412002	Remache tubular Ø4x7,5		14	14	14								
25	R660606	Cristal exterior 6/11		1	-	-								
25	R670625	Cristal exterior 10/11		-	1	-								
25	R680609	Cristal exterior 10/21		-	-	1								
26	R660549	Guia eje inferior		1	1	1								
27	Q062040	Tornillo avellanado M-6x16		4	4	4								
28	R660551	Bisagra inferior		1	1	1								
29	Q242040	Arandela abanico A-6		2	2	2								
30	Q012041	Tornillo exagonal M-6x10		2	2	2								
31	T130502	Manilla		1	1	1								
32	Q132042	Varilla roscada M-6x15		1	1	1								
33	T130507	Piton enganche		2	2	2								
34	T130506	Resorte		2	2	2								
35	T130515	Guia manilla		1	1	1								
36	T130513	Soporte iman		1	1	1								
37	Z200507	Protector iman		1	1	1								

MOD.

HORNOS A GAS HCG

ZONA

PUERTA

PLANO

C-1340

ITEM	CODIGO	DENOMINACION	TEXTO	HCG-6/11	HCG-10/11	HCG-10/21	HCG-2-10/11							NOTAS
38	Z200506	Iman		1	1	1								
39	Z100522	Interruptor magnetico		1	1	1								
40	T130514	Soporte resortes		1	1	1								
41	Q032032	Tornillo alomado M-5x15		2	2	2								
42	T130511	Suplemento fijacion cerradura		1	1	1								
43	Z608410	Casquillo		2	2	2								
44	Q352001	Pasador de aletas Ø2x15		4	4	4								
45	Q042043	Tornillo avellanado M-6x20		4	4	4								
46	R260545	Enganche		2	2	2								
47	R660538	Calzo de enganche		4	4	4								
48	Q221343	Remache exagonal M-6		4	4	4								
49	T080503	Suplemento elemento cierre		6	6	6								
50	T080504	Elemento de cierre		2	2	2								
51	Q262040	Arandela muelle A-6		8	8	8								
52	Q162040	Tuerca exagonal M-6		8	8	8								
53	R020502	Tubo alargadera		-	2	2								
54	T130509	Mecanismo de cierre		1	1	1								
55	Q262040	Arandela muelle A-6		2	2	2								
56	Q162040	Tuerca exagonal M-6		2	2	2								
57	T130508	Eje de manilla		1	1	1								
58	T130505	Casquillo		1	1	1								
59	Q271033	Arandela de seguridad Ø6		1	1	1								
60	Q032031	Tornillo alomado M-5x10		2	2	2								
60	Q032021	Tornillo alomado M-4x10		2	2	2								
61	T080502	Tapa cierre puerta		1	-	-								
61	T110502	Tapa cierre puerta		-	1	1								
62	1100002806	KIT Cristal interior completo 6/11		1	-	-								
62	1100002807	KIT Cristal interior completo 10/11		-	1	-								
62	1100002808	KIT Cristal interior completo 10/21		-	-	1								



ITEM	CODIGO	DENOMINACION	TEXTO	HCG-6/11	HCG-10/11	HCG-10/21	HCG-2-10/11						NOTAS
63	R660526	Fijacion junta completa 6/11		1	-	-							
63	R670513	Fijacion junta completa 10/11		-	1	-							
63	R680511	Fijacion junta completa 10/21		-	-	1							
	Q033021	Tornillo alomado M-4x10 ( laton )		28	28	28							
	Q222041	Remache exagonal M-4 inox.		28	28	28							
64	R660503	Junta de puerta 6/11		1	-	-							
64	R670500	Junta de puerta 10/11		-	1	-							
64	R680500	Junta de puerta 10/21		-	-	1							

N plano C-1341  
 Firma   
 Fecha 5-2003  
 Aparato HORNOS A GAS HCG-6/11,10/11,10/21  
 MUEBLE INTERIOR  
 Laminas 3  
 Fagor Industrial S. Coop.   
 Oñate

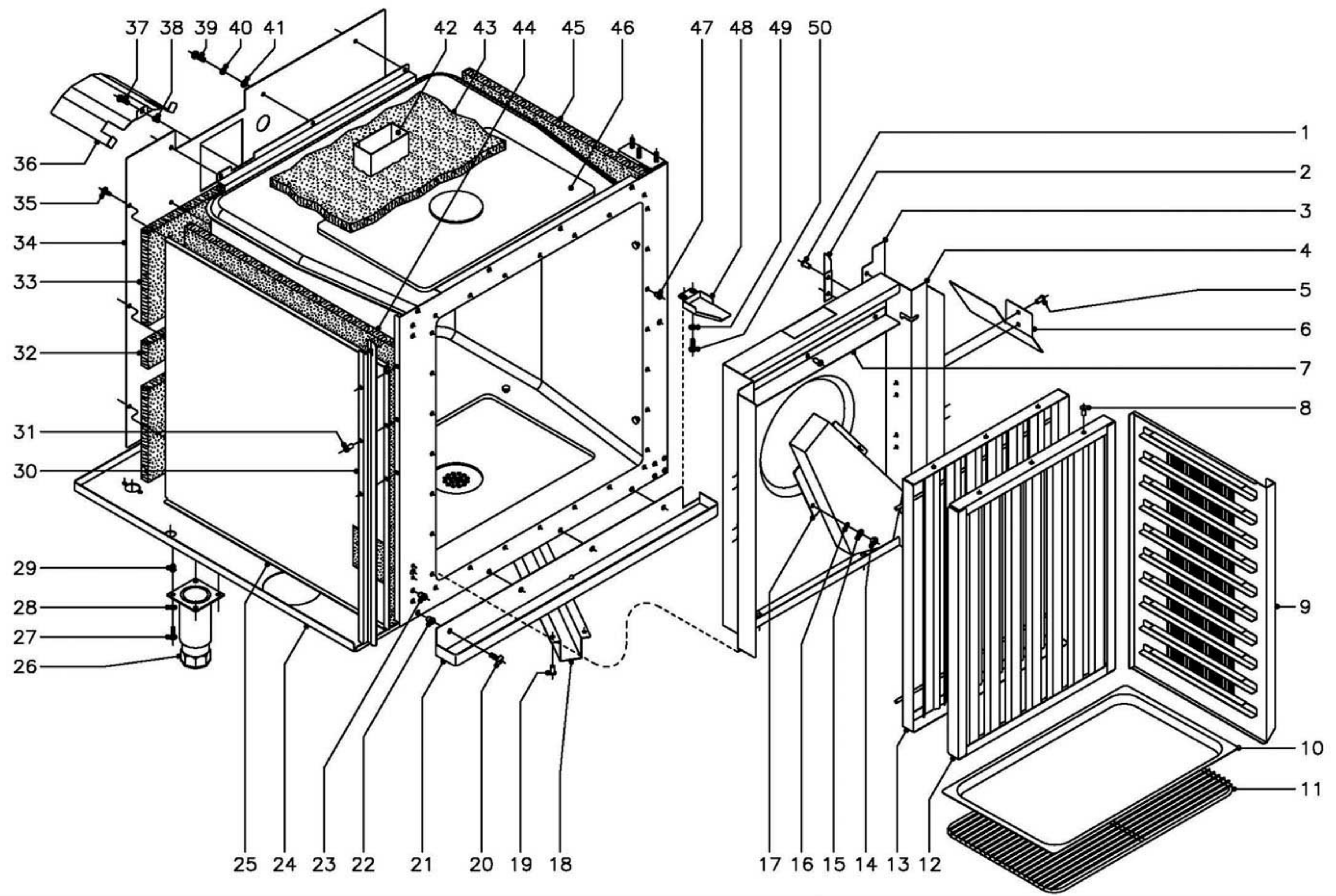

MOD.

HORNOS A GAS HCG

ZONA

MUEBLE INTERIOR

PLANO

C-1341

ITEM	CODIGO	DENOMINACION	TEXTO	HCG-6/11	HCG-10/11	HCG-10/21	HCG-2-10/11							NOTAS
1	Q412002	Remache tubular Ø 4x7,5		4	4	4	4							
2	R292647	Escuadra sujecion cubreventilador		2	2	2	2							
3	R662648	Aleron derecho		1	-	-	-							
s/n	R662647	Aleron izquierdo		1	-	-	-							
4	T082602	Cubre ventilador		1	-	-	-							
4	T012602	Cubre ventilador		-	1	-	-							
4	T022605	Cubre ventilador		-	-	1	1							
5	Q412002	Remache tubular Ø 4x7,5		-	8	8	8							
6	T012611	Aleron cubreventilador		-	4	4	4							
7	T012612	Separador		1	1	1	1							
	Q412002	Remache tubular Ø 4x7,5		3	3	3	3							
8	Q412002	Remache tubular Ø 4x7,5		6	6	6	6							
9	R662668	Guia de bandejas derecha		1	-	-	-							
s/n	R662670	Guia de bandejas izquierda		1	-	-	-							
9	T112615	Guia de bandejas derecha		-	1	-	-							
s/n	T112617	Guia de bandejas izquierda		-	1	-	-							
9	T122614	Guia de bandejas derecha		-	-	1	-							
s/n	T122616	Guia de bandejas izquierda		-	-	1	-							
10	R252816	Bandeja 1/1 ( 530x325x20 )		1	1	-	1							
10	R032605	Bandeja 2/1 ( 530x650x40 )		-	-	1	-							
11	R672665	Parrilla 1/1		1	1	-	1							
11	R682676	Parrilla 2/1		-	-	1	-							
12	R662617	Anterior de filtro		1	-	-	-							
12	R092618	Anterior de filtro		-	1	1	1							
13	R662622	Posterior de filtro		1	-	-	-							
13	R092621	Posterior de filtro		-	1	1	1							
14	Q162030	Tuerca exagonal M-5		2	2	2	2							
15	Q242030	Arandela abanico A-5		2	2	2	2							
16	Q232030	Arandela plana A-5		2	2	2	2							

MOD.

HORNOS A GAS HCG

ZONA

MUEBLE INTERIOR

PLANO

C-1341

ITEM	CODIGO	DENOMINACION	TEXTO	HCG-6/11	HCG-10/11	HCG-10/21	HCG-2-10/11							NOTAS
17	T082604	Conduccion de humos		1	-	-	-							
17	T012607	Conduccion de humos		-	1	1	1							
18	R672804	Cubre desagüe		1	1	-	-							
18	R682805	Cubre desagüe		-	-	1	1							
19	Q412002	Remache tubular Ø 4x7,5		8	8	8	8							
20	Q152017	Tornillo amarre M-6x13		4	4	4	4							
21	T112813	Recoge aguas		1	1	-	-							
21	T122811	Recoge aguas		-	-	1	1							
22	Q221343	Remache exagonal M-6		4	4	4	4							
23	Q221343	Remache exagonal M-6		8	8	8	8							
24	R722900	Base exterior de horno		1	1	-	-							
24	R732900	Base exterior de horno		-	-	1	1							
25	T072614	Soporte lateral aislante		1	-	-	-							
25	T112624	Soporte lateral aislante		-	1	-	-							
25	T122619	Soporte lateral aislante		-	-	1	1							
26	X260151	Pata regulable		4	4	4	4							
27	Q012031	Tornillo exagonal M-5x10		16	16	16	16							
28	Q242030	Arandela abanico A-5		16	16	16	16							
29	Q221342	Remache exagonal M-5		16	16	16	16							
30	R662682	Protector portamandos		1	-	-	-							
30	R672674	Protector portamandos		-	1	1	1							
31	Q412002	Remache tubular Ø 4x7,5		3	3	3	3							
32	R662616	Aislante posterior 560x60x20		4	4	4	4							
33	R672631	Aislante posterior 670x230x20		2	2	-	-							
33	R032625	Aislante posterior 760x230x20		-	-	2	2							
34	T072705	Soporte aislante posterior		1	-	-	-							
34	T112607	Soporte aislante posterior		-	1	-	-							
34	T122604	Soporte aislante posterior		-	-	1	1							
35	Q151301	Tornillo alomado		3	3	3	3							

ITEM	CODIGO	DENOMINACION	TEXTO	HCG-6/11	HCG-10/11	HCG-10/21	HCG-2-10/11							NOTAS
36	R142628	Tejadillo motor turbina		1	1	1	1							
s/n	R142614	Tejadillo ventilador soplante		1	1	1	1							
37	Q012042	Tornillo exagonal M-6x15		4	4	4	4							
38	Q221343	Remache exagonal M-6		4	4	4	4							
39	Q012042	Tornillo exagonal M-6x15		12	12	12	12							
40	Q262040	Arandela muelle A-6		12	12	12	12							
41	Q232040	Arandela plana A-6		12	12	12	12							
42	T012605	Chimenea interior		1	1	1	1							
	Q412002	Remache tubular Ø 4x7,5		6	6	6	6							
43	R662614	Aislante base y techo 650x650x20		5	5	-	-							
43	R682623	Aislante base y techo 870x790x20		-	-	5	5							
44	R662613	Aislante lateral 650x530x20		3	-	-	-							
44	R672630	Aislante lateral 770x650x20		-	3	-	-							
44	R682623	Aislante lateral 860x790x20		-	-	3	3							
45	R662613	Aislante lateral 650x530x20		2	-	-	-							
45	R672630	Aislante lateral 770x650x20		-	2	-	-							
45	R682623	Aislante lateral 860x790x20		-	-	2	2							
46	T082610	Cuerpo interior horno		1	-	-	-							
46	T012615	Cuerpo interior horno		-	1	-	-							
46	T022608	Cuerpo interior horno		-	-	1	1							
47	Q221341	Remache exagonal M-4		24	28	28	28							
48	R662800	Cubre cables		1	1	1	1							
49	Q232030	Arandela plana A-5		2	2	2	2							
50	Q012031	Tornillo exagonal M-5x10		2	2	2	2							

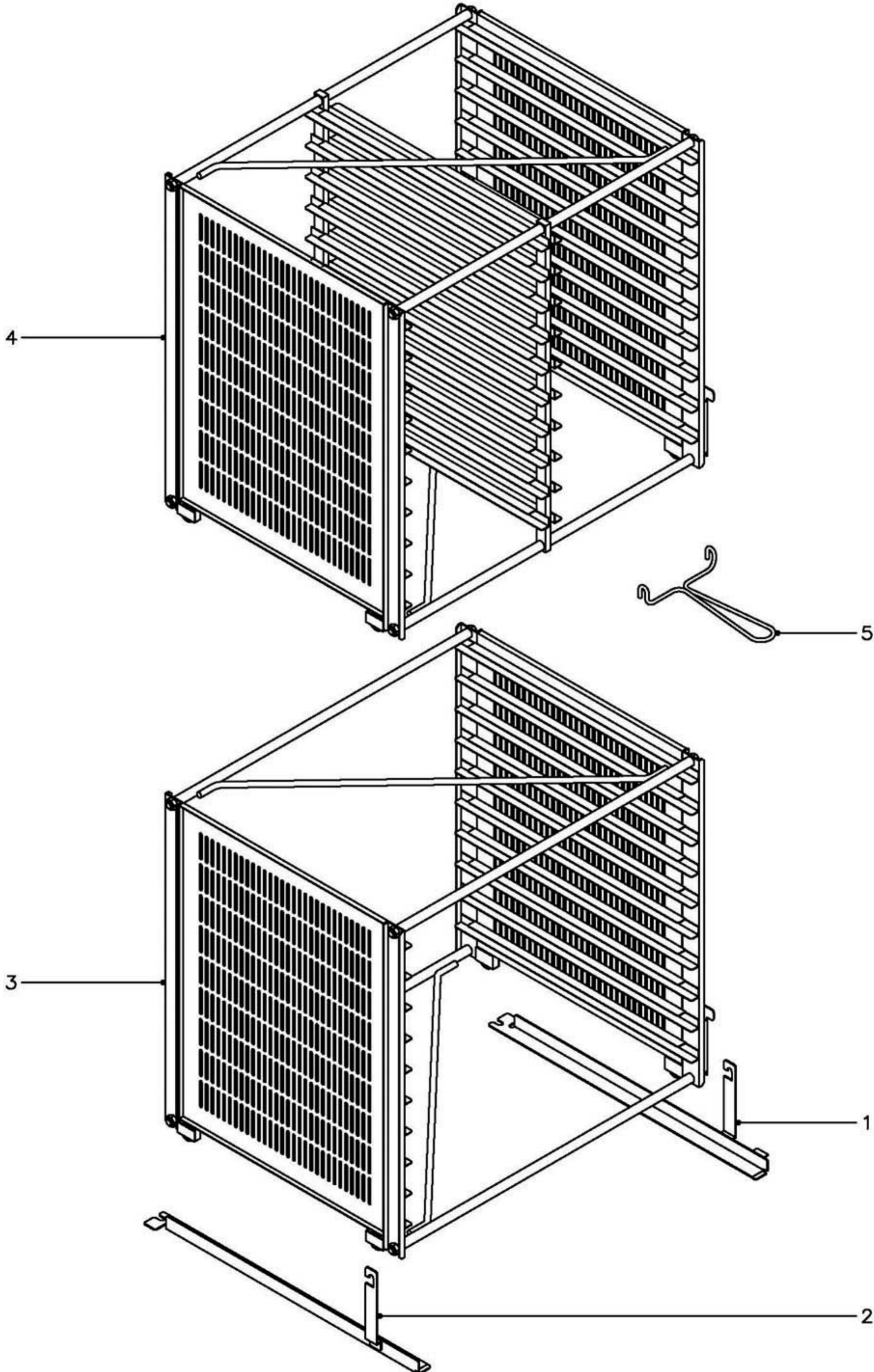

N plano C-1342	Firma 	Fecha 5-2003	Aparato EXTRUCTURAS PORTABANDEJAS HORNOS A GAS HCG-10/11,10/21	Lamina 4	Fagor Industrial S.Coop. <b>FAGOR</b>  Ofite
-------------------	--	-----------------	--	-------------	--

ITEM	CODIGO	DENOMINACION	TEXTO	HCG-10/11	HCG-10/21	HCG-2-10/11								NOTAS
1100002631 KIT EXSTRUCTURA PORTABANDE. 10/11													OP.= Opcional	
1	R672623	Rail derecho		OP.	-	-								Optionnel
2	R672622	Rail izquierdo		OP.	-	-								In option
3	R672617	Exstructura portabandejas 10/11		OP.	-	-								
5	R672632	Tirador de estructura		OP.	-	-								
1100002634 KIT EXSTRUCTURA PORTABANDE. 10/21														
1100002635 KIT EXSTRUCTURA PORTABANDE. 2-10/11														
1	R682659	Rail derecho		-	OP.	-								
2	R682658	Rail izquierdo		-	OP.	1								
3	R682617	Exstructura portabandejas 10/21		-	OP.	-								
4	R682618	Exstructura portabandejas 2-10/11		-	-	1								
5	R672632	Tirador de estructura		-	OP.	1								

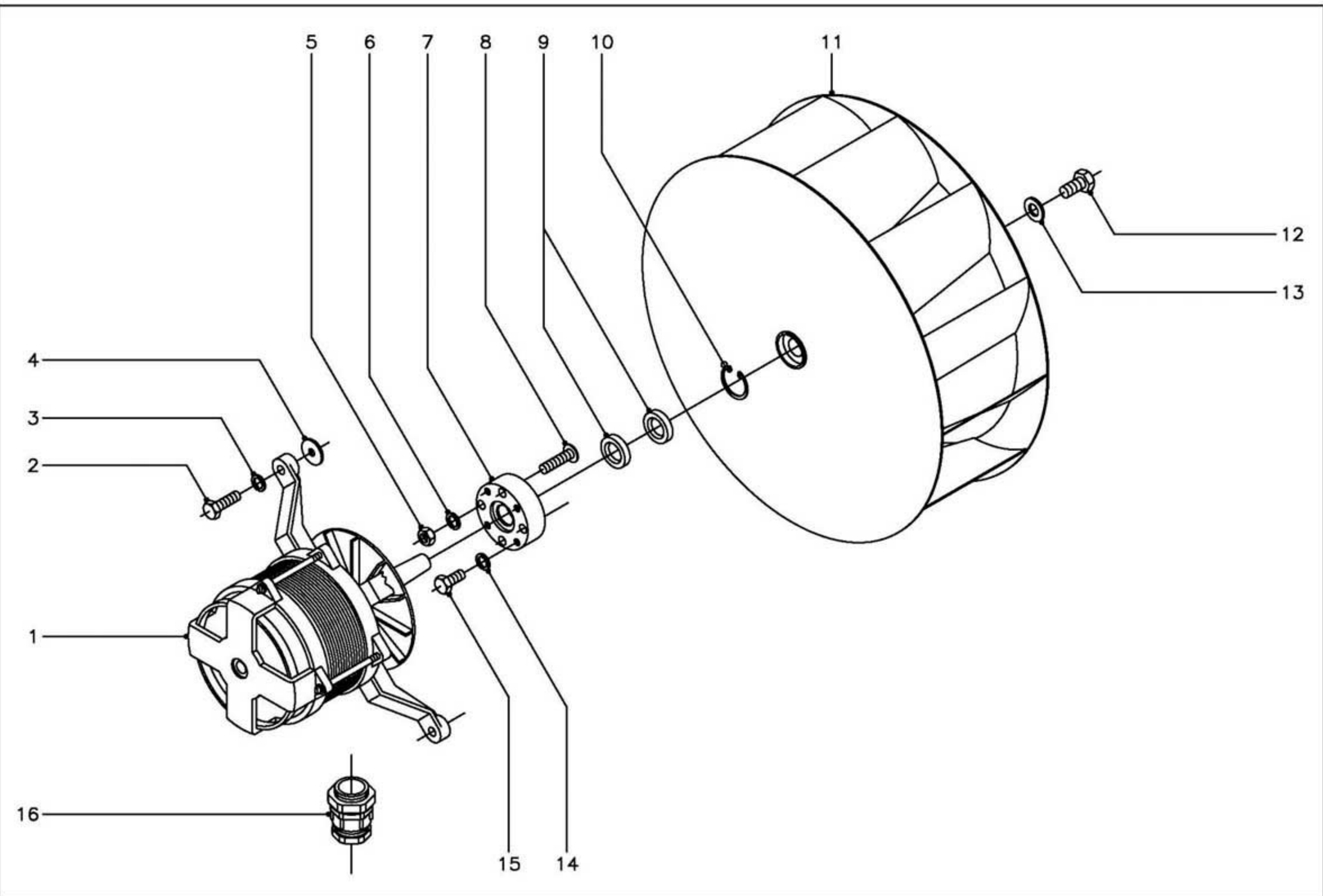

N plano	Firma	Fecha	Aparato	Lamina	Fagor Industrial S.Coop. <b>FAGOR</b>
C-1343		5-2003	TURBINA HORNOS A GAS HCG-6/11,10/11,10/21	5	Orote



MOD.

HORNOS A GAS HCG

ZONA

TURBINA

PLANO

C-1343

ITEM	CODIGO	DENOMINACION	TEXTO	HCG-6/11	HCG-10/11	HCG-10/21	HCG-2-10/11										NOTAS
1	R253049	Conj. motor ( 230/400 V., 50/60 Hz.)		1	1	1											
2	Q012044	Tornillo exagonal M-6x25		4	4	4											
3	Q262040	Arandela muelle A-6		4	4	4											
4	Q301304	Arandela calzo Ø 23xØ 6,5x2		8	8	8											
5	Q162040	Tuerca exagonal M-6		4	4	4											
6	Q262040	Arandela muelle A-6		4	4	4											
7	R662623	Casquillo reten		1	1	1											
8	-	Perno M-6 ( Caldeado a cuerpo )		4	4	4											
9	R662627	Reten Ø 28xØ 17x7		2	2	2											
10	Q302023	Anillo de seguridad Ø 28x1,2		1	1	1											
11	T073000	Turbina		1	-	-											
11	R253042	Turbina		-	1	1											
12	Q012063	Tornillo exagonal M-10x20		1	1	1											
13	R763010	Arandela seguridad Hanning		1	1	1											
14	Q232030	Arandela muelle A-5		4	4	4											
15	Q012031	Tornillo exagonal M-5x10		4	4	4											
16	R073004	Prensaestopas		1	1	1											

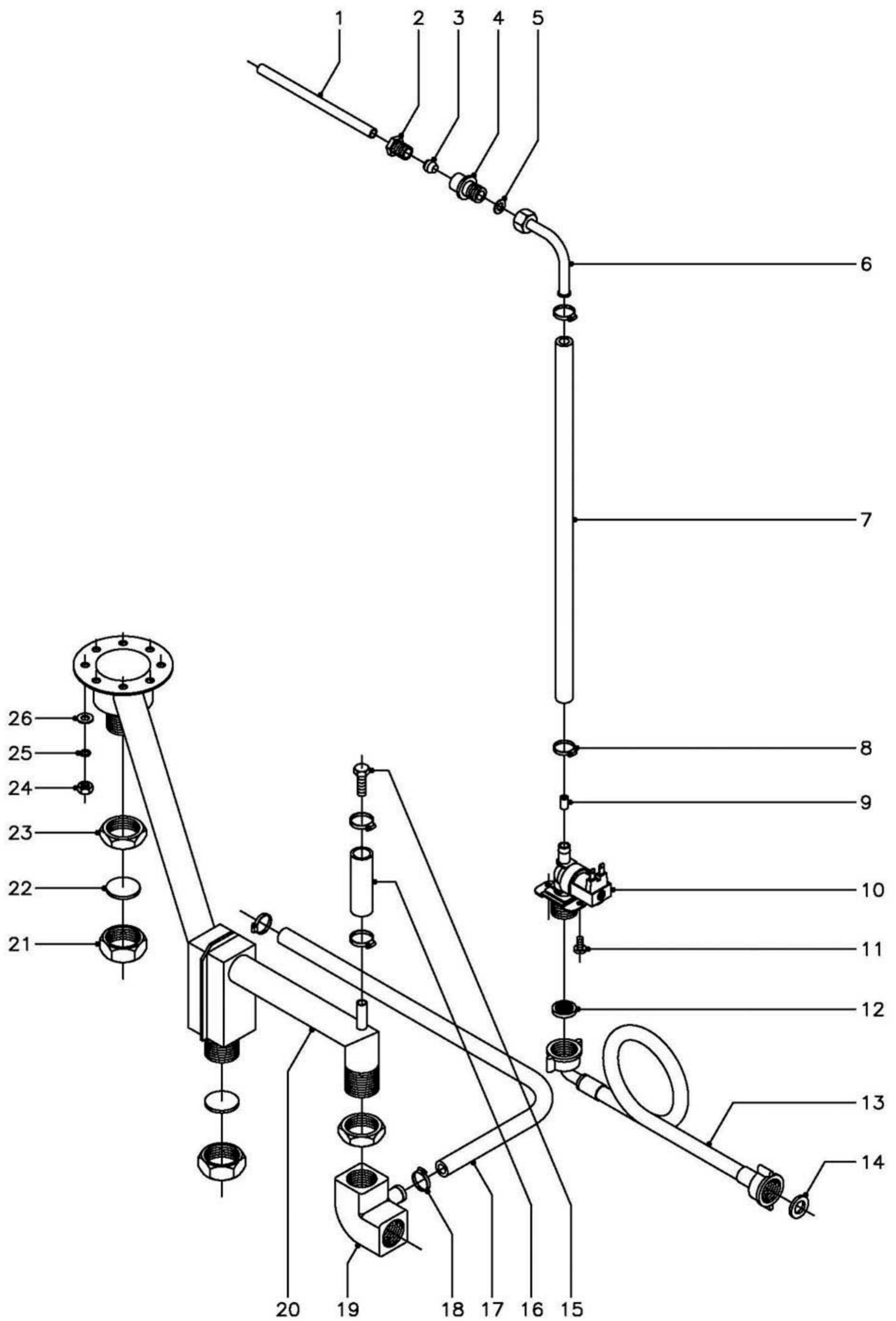

N plano  
C-1344

Firma

Fecha  
5-2003

Aparato  
HORNOS A GAS HCG-6/11,10/11,10/21

CIRCUITO DE AGUA

Lamina  
6

Fagor Industrial S.Coop. **FAGOR**  
Oñate

MOD.

HORNOS A GAS HCG

ZONA



CIRCUITO DE AGUA

PLANO

C-1344

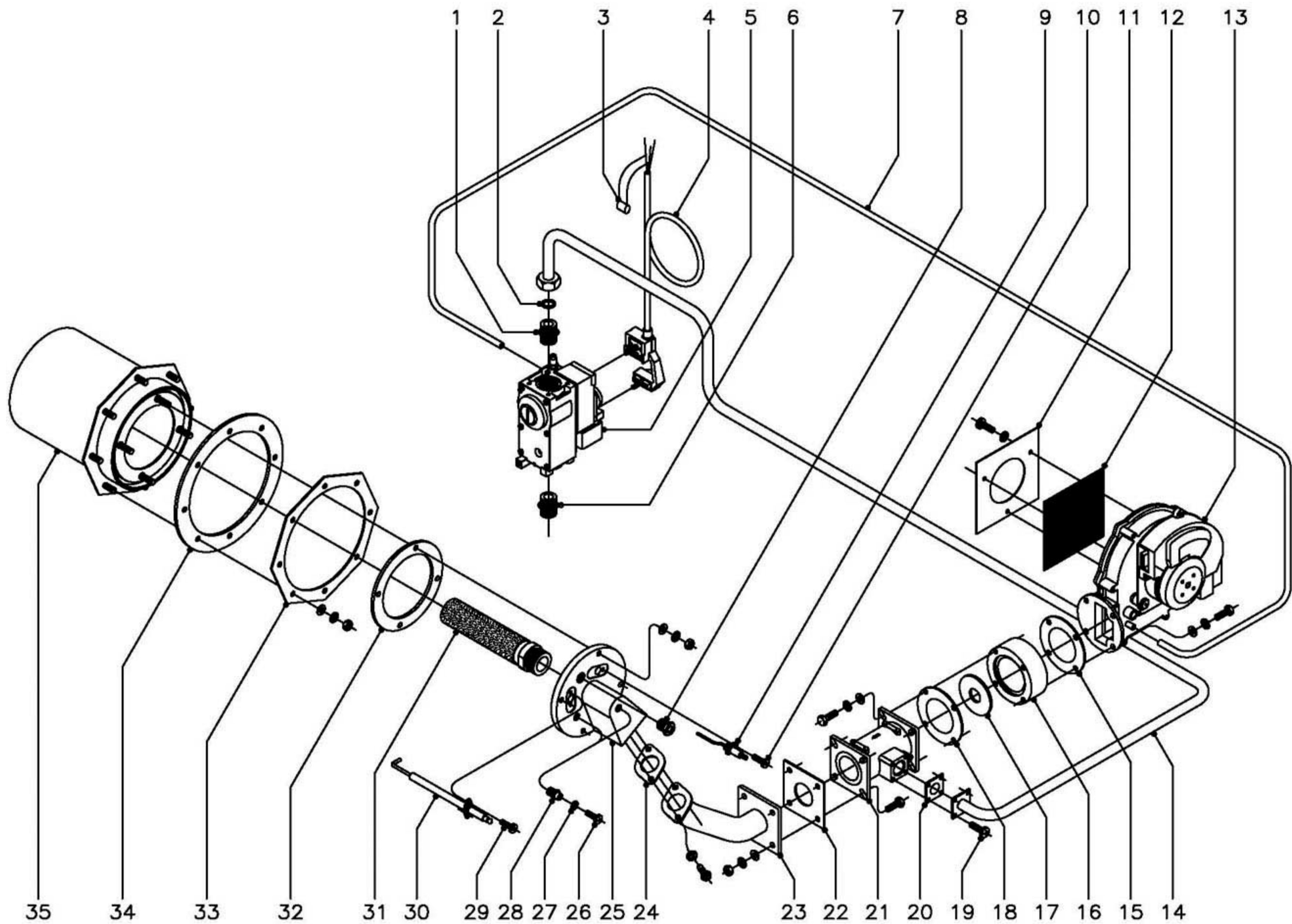
ITEM	CODIGO	DENOMINACION	TEXTO	HCG-6/11	HCG-10/11	HCG-10/21	HCG-2-10/11									NOTAS
1	R020502	Tubo alargadera		1	1	1										
2	R695003	Manguito cierre		1	1	1										
3	R695004	Bicono		1	1	1										
4	-	Casquillo soldado a cuerpo de horno		1	1	1										
5	Q306026	Arandela junta Ø 14xØ 8,5x1,5		1	1	1										
6	R695017	Tubo conduccion agua		1	1	1										
7	3676900	Tubo goma negra Ø17xØ10x1000		1	1	1										
8	Q881302	Abrazadera 12 - 20		6	6	6										
9	R665041	Regulador caudal 0,25l. (verde)		1	1	1										
10	Z701135	Electrovalvula entrada agua		1	1	1										
11	Q032021	Tornillo alomado M-4x10		2	2	2										
12	Z701132	Filtro-junta entrada de agua		1	1	1										
13	Z601114	Manguera entrada de agua		1	1	1										
14	Q307031	Junta manguera Ø24xØ14x3		1	1	1										
15	Q012053	Tornillo exagonal M-8x20		1	1	1										
16	3676900	Tubo goma negra Ø17xØ10x100		1	1	1										
17	3715600	Tubo silicona forrado Ø26xØ18x1000		1	1	1										
18	Q881304	Abrazadera 20 - 32		2	2	2										
19	R665067	Codo desagüe		1	1	1										
20	R725004	Tubo desagüe completo		1	1	-										
20	R735004	Tubo desagüe completo		-	-	1										
21	R665053	Tuerca tapon		2	2	2										
22	R015011	Arandela junta Ø 34x3		2	2	2										
23	Q223014	Contratuerca 1"		2	2	2										
24	Q162040	Tuerca exagonal M-6		8	8	8										
25	Q262040	Arandela muelle A-6		8	8	8										
26	Q232040	Arandela plana A-6		8	8	8										



N plano C-1345	Firma 	Fecha 5-2003	Aparato PARTE FUNCIONAL GAS HORNOS A GAS HCG-6/11,10/11,10/21	Lamina 7	Fogor Industrial S.Coop. <b>FAGOR</b>  Oñate
-------------------	--	-----------------	---	-------------	--

MOD.		HORNOS A GAS HCG		ZONA		PARTE FUNCIONAL GAS						PLANO		C-1345
ITEM	CODIGO	DENOMINACION	TEXTO	HCG-6/11	HCG-10/11	HCG-10/21	HCG-2-10/11							NOTAS
1	S205023	Manguito doble 1/2"		1	1	1								
2	Q306012	Arandela junta Ø18xØ13x1,5		1	1	1								
3	Z233012	Condensador antiparasitario		1	1	1								
4	T085012	Conector valvula Honeywell		1	1	1								
5	T085010	Valvula Honeywell ( Regulado a B.P.)		1	-	-								( 50 Hz.)
5	T085011	Valvula Honeywell ( Regulado a G.N.)		1	-	-								( 50 Hz.)
5	T115097	Valvula Honeywell ( Regulado a B.P.)		-	1	1								( 50 Hz.)
5	T115098	Valvula Honeywell ( Regulado a G.N.)		-	1	1								( 50 Hz.)
5	T085016	Valvula Honeywell ( Regulado a B.P.)		1	-	-								( 60 Hz.)
5	T085017	Valvula Honeywell ( Regulado a G.N.)		1	-	-								( 60 Hz.)
5	T115100	Valvula Honeywell ( Regulado a B.P.)		-	1	1								( 60 Hz.)
5	T115101	Valvula Honeywell ( Regulado a G.N.)		-	1	1								( 60 Hz.)
6	S205023	Manguito doble 1/2"		1	1	1								
7	3702400	Tubo goma negra Ø 8xØ 4x1500		1	1	1								
8	R725015	Visor de encendido		1	1	1								
9	T115712	Electrodo de deteccion		1	1	1								
10	Q153021	Tornillo alomado M-4x10		1	1	1								
11	T115096	Chapa amarre malla ventilador		1	1	1								
	Q032021	Tornillo alomado M-4x10		3	3	3								
	Q242020	Arandela abanico A-4		3	3	3								
12	T115095	Malla ventilador		1	1	1								
13	T083000	Ventilador E.B.M.-RG130		1	1	1								
14	T015000	Conduccion de gas completo		1	1	-								
14	T025000	Conduccion de gas completo		-	-	1								
15	T115081	Junta acoplamiento ventilador y mixer		1	1	1								
16	T115076	Acoplamiento ventilador mixer		1	1	1								
17	T085018	Arandela regulacion ventilador Ø14		1	-	-								(But. Pro. Y Gas Natural)
17	T115082	Arandela regulacion ventilador Ø18		-	1	1								( Butano-Propano
17	T115083	Arandela regulacion ventilador Ø20		-	1	1								( Gas Natural )

MOD.		HORNOS A GAS HCG		ZONA	PARTE FUNCIONAL GAS					PLANO	C-1345	
ITEM	CODIGO	DENOMINACION	TEXTO	HCG-6/11	HCG-10/11	HCG-10/21	HCG-2-10/11					NOTAS
18	T115081	Junta acoplamiento ventilador y mixer		1	1	1						
19	Q032021	Tornillo alomado M-4x10		4	4	4						
20	T115080	Junta conduccion mixer		1	1	1						
21	T085007	Mixer 25 KW.		1	-	-						
21	T115075	Mixer 35 KW.		-	1	1						
22	T115079	Junta mixer conducto		1	1	1						
23	T115077	Conducto mixer tapa principal		1	1	1						
24	T095021	Junta conducto tapa		1	1	1						
25	T085715	Tapa principal		1	-	-						
25	T115782	Tapa principal		-	1	1						
26	Q152024	Tornillo avellanado M-4x8		2	2	2						
27	R725061	Junta toma de presion		2	2	2						
28	R725017	Boquilla toma de presion		2	2	2						
29	Q153021	Tornillo alomado M-4x10		1	1	1						
30	T085714	Electrodo de ignicion		1	-	-						
30	T115781	Electrodo de ignicion		-	1	1						
31	T085710	Quemador Furigas ( 6/11 )		1	-	-						
31	T115710	Quemador Furigas ( 10/11 y 10/21 )		-	1	1						
32	T075013	Junta de tapa principal		1	-	-						
32	R725055	Junta de tapa principal		-	1	1						
33	-	Brida amarre camara combustion		-	-	-						Caldeado a cuerpo de horno
34	T075014	Junta camara combustion		1	-	-						
34	R725051	Junta camara combustion		-	1	1						
35	T085713	Camara de combustion		1	-	-						
35	T015700	Camara de combustion		-	1	1						
	Q232040	Arandela plana A-6		8	8	8						
	Q262040	Arandela muelle A-6		8	8	8						
	Q163040	Tuerca exagonal M-6 (laton)		8	8	8						

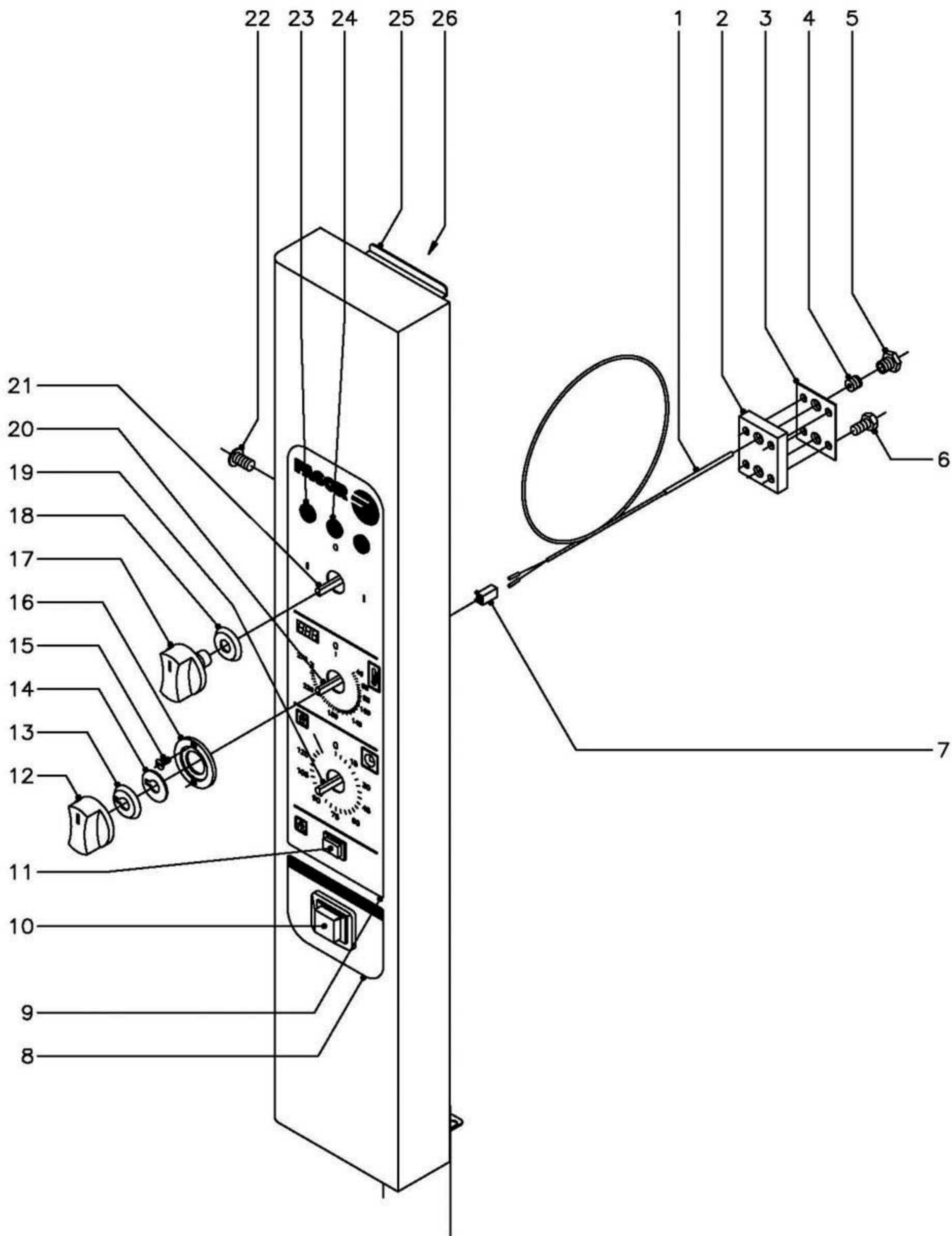

N plano  
C-1346

Firma

Fecha  
5-2003

Aparato PARTE ELECTRICA PORTAMANDOS  
HORNOS A GAS HCG-6/11,10/11,10/21

Lamina  
8

Fogor Industrial S.Coop. **FAGOR**

Ortote

MOD.

HORNOS A GAS HCG

ZONA

PARTE ELECTRICA PORTAMANDOS

PLANO

C-1346

ITEM	CODIGO	DENOMINACION	TEXTO	HCG-6/11	HCG-10/11	HCG-10/21	HCG-2-10/11											NOTAS
1	R663090	Conjunto termopar L=1400		1	1	1												
2	R662659	Pasamuros doble		1	1	1												
3	R692811	Junta pasamuros doble		1	1	1												
4	R662652	Bicono cierre sonda		1	1	1												
5	R662629	Racord cierre sonda		1	1	1												
6	Q012021	Tornillo exagonal M-4x10		4	4	4												
7	R663092	Conector 2 vias		1	1	1												
8	R723008	Serigrafia inferior		1	1	1												
9	T013006	Serigrafia superior		1	1	1												
10	Z213033	Pulsador de rearme		1	1	1												
11	R663032	Pulsador		1	1	1												
12	R663063	Boton de mando Ø6 (termos.elec.)		1	1	1												
13	R663045	Junta (termostato electronico)		1	1	1												
14	R662810	Arandela guia		1	1	1												
15	Q151346	Tornillo avellanado M-3x5		2	2	2												
16	R662809	Guia boton de mando		1	1	1												
17	R663062	Boton de mando Ø6 (conmutadores)		2	2	2												
18	R663046	Junta (conmutadores)		2	2	2												
19	R723000	Temporizador manual		1	1	1												
20	R743013	Termostato electronico 0 - 270° C.		1	1	1												
	R663036	Fijacion circuito termost. electroni.		4	4	4												
21	T013001	Conmutador de funciones		1	1	1												
22	Q152004	Tornillo aplastado M-5x13		2	2	2												
23	R693056	Piloto ambar		2	2	2												
24	R693055	Piloto verde		1	1	1												
25	T082810	Panel portamandos		1	-	-												
25	T012809	Panel portamandos		-	1	1												
26	T012803	Soporte componentes		1	1	1												



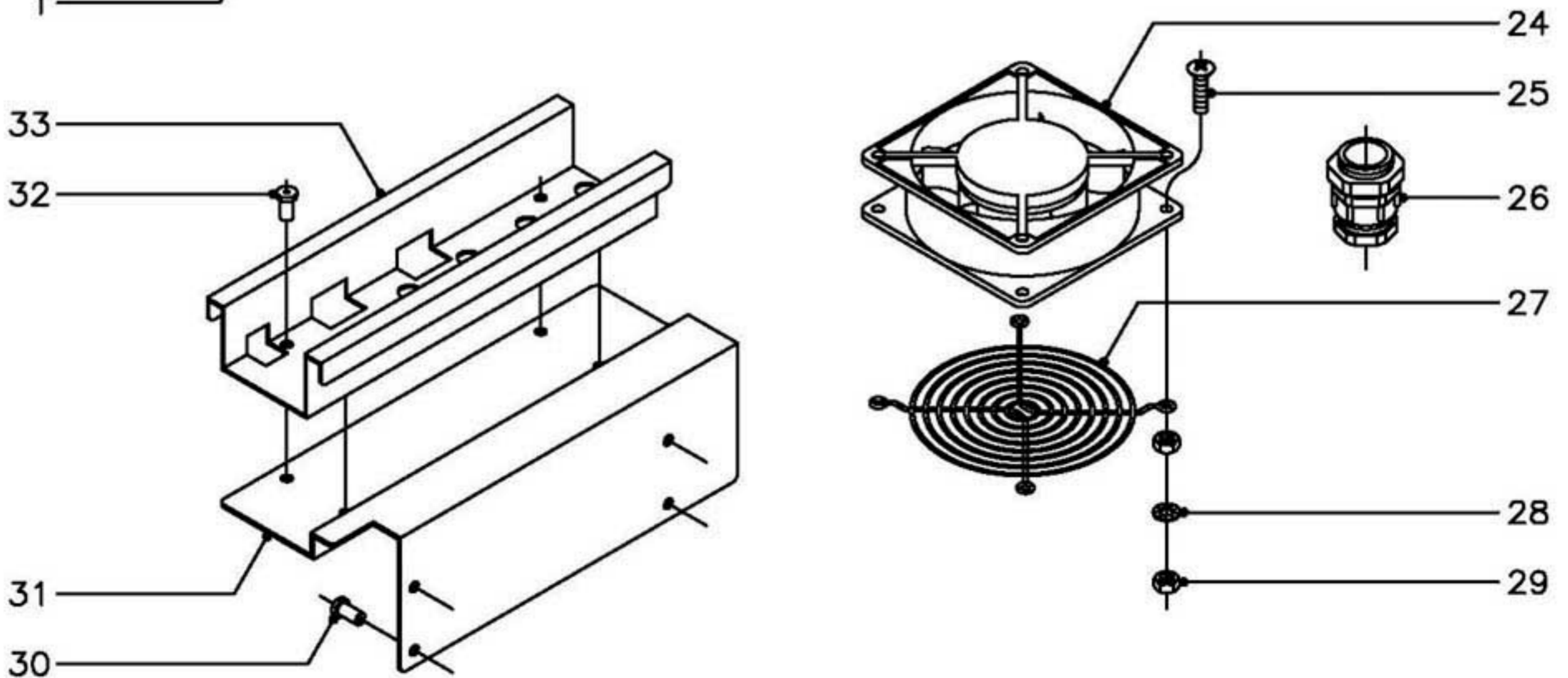
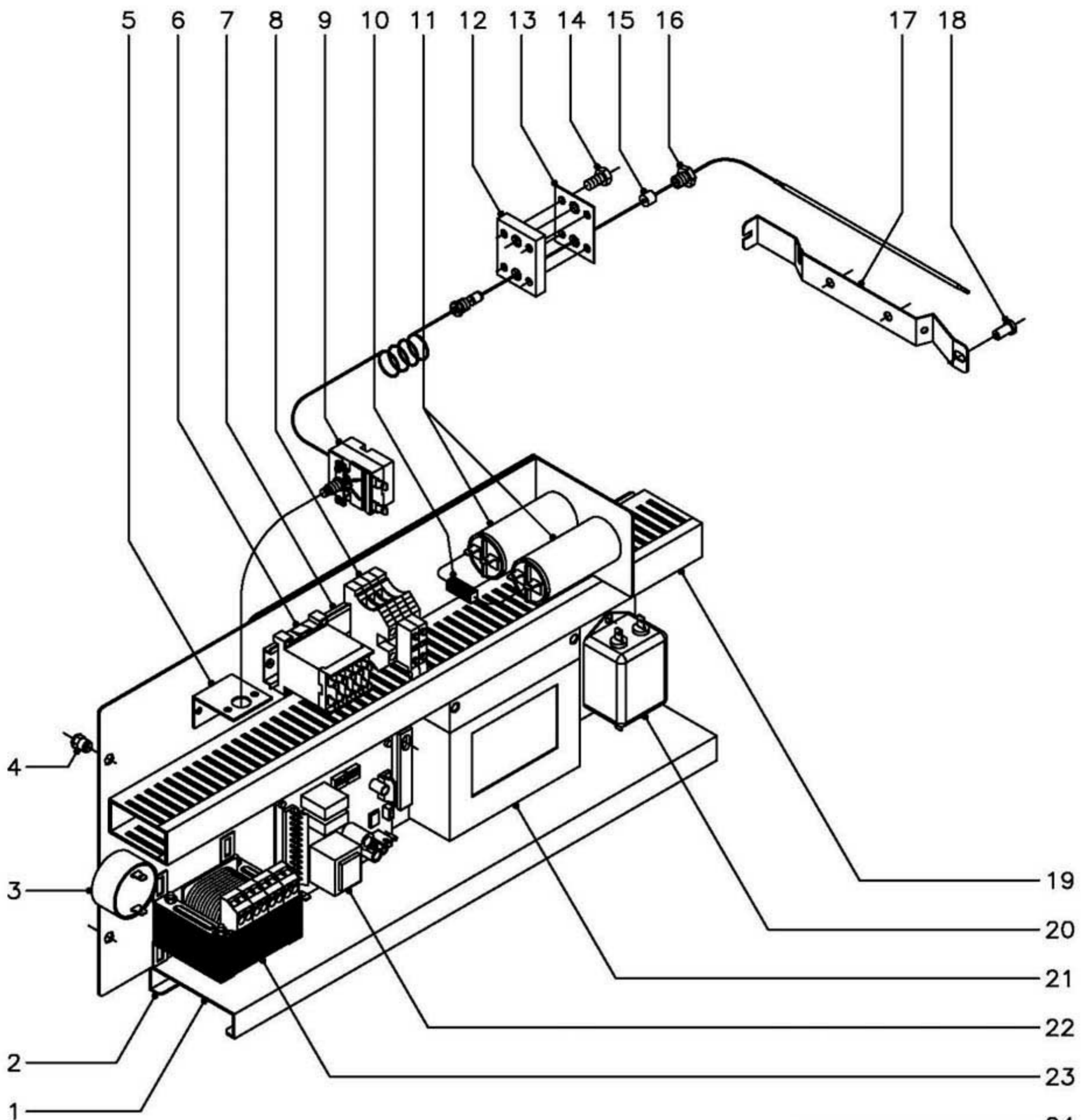

MOD.

HORNOS A GAS HCG

ZONA

PANEL CUADRO ELECTRICO

PLANO

C-1347

ITEM	CODIGO	DENOMINACION	TEXTO	HCG-6/11	HCG-10/11	HCG-10/21	HCG-2-10/11							NOTAS
1	T083003	Panel cuadro electrico		1	1	1								
2	R723101	Contraigua panel cuadro electrico		1	1	1								
	Q412002	Remache tubular Ø 4x7,5		8	8	8								
3	R693067	Zumbador		1	1	1								
4	Q221342	Remache exagonal M-5		2	2	2								
5	R343039	Soporte termostato		1	1	1								
6	Z683087	Contacto		1	1	1								
7	R663055	Guia contactor L=120		1	1	1								
8	R073005	Borna portafusible		2	2	2								
	R723015	Fusible cristal 10 A.		2	2	2								
	P453026	Borne tierra 10		1	1	1								
	Z263303	Tope final		1	1	1								
9	R243016	Termostato limitador		1	1	1								
	Q162050	Tuerca exagonal M-8x1		1	1	1								
10	R073008	Cableado PTC		1	1	1								
11	R293000	Condensador		2	2	2								
12	R662659	Pasamuros doble		1	1	1								
13	R692811	Junta pasamuros doble		1	1	1								
14	Q012021	Tornillo exagonal M-4x10		4	4	4								
15	R662662	Junta cierre bulbo limitador		1	1	1								
16	R662629	Racord cierre sonda		1	1	1								
17	R662630	Soporte bulbo		1	1	1								
18	Q412002	Remache tubular Ø 4x7,5		3	3	3								
19	3715520	Canaleta unex ( 60x30xlonjitud )		4	4	4								
20	T113023	Filtro de entrada modelo FF-6Z		1	1	1								
21	Z953004	Control combustion		1	1	1								
22	T083002	Variador de velocidad		1	1	1								
	T133007	Distanciador M-3		4	4	4								Amarre variador a cuadro
	T133008	Tornillo amarre M-3x23 ( plastico )		4	4	4								Amarre variador a cuadro

MOD.

HORNOS A GAS HCG

ZONA

PANEL CUADRO ELECTRICO

PLANO

C-1347

ITEM	CODIGO	DENOMINACION	TEXTO	HCG-6/11	HCG-10/11	HCG-10/21	HCG-2-10/11							NOTAS
	Q161310	Tuerca exagonal M-3		4	4	4								Amarre variador a cuadro
23	R503005	Transformador		1	1	1								
24	Z103066	Ventilador 230 V., 50 - 60 Hz.		2	2	2								
25	Q042022	Tornillo avellanado M-4x15		8	8	8								
26	R073004	Prensaestopas		1	1	1								
27	T113015	Protector ventilador		2	2	2								
28	Q242020	Arandela abanico A-4		8	8	8								
29	Q162020	Tuerca exagonal M-4		16	16	16								
30	Q411304	Remache avibulb Ø 4,8		4	4	4								
31	T083004	Pedestal cuadro electrico		1	1	1								
32	Q411304	Remache avibulb Ø 4,8		4	4	4								
33	R342821	Guia cuadro electrico		1	1	1								

MOD.

HORNOS A GAS HCG

ZONA

VARIOS

PLANO

ITEM

CODIGO

DENOMINACION

TEXTO

HCG-6/11

HCG-10/11

HCG-10/21

HCG-2-10/11

NOTAS

T116502

Folleto de instrucciones

1

1

1

T013044

Esquema electrico adhesivo

1

1

1

Plano HC-75723

T113028

Leyenda esquema electrico

1

1

1

Plano HC-75483

T013046

Esquema electrico de montaje

1

1

1

Plano HD-12792

T013045

Instalacion electrica

1

1

1

T113035

Cableado luz interior

1

1

1

R663094

Cableado luz puerta

1

1

1

3713900

Funda roja o negra Ø 6,4x500

1

1

1

T133032

Cable de encendido L=1800

1

1

-

T113033

Cable de encendido L=2000

-

-

1

T113036

Cableado variador soplante

1

1

1

MOD.

HORNOS A GAS HCG

ZONA

PIEZAS ESPECIFICAS PARA LOS DISTINTOS GASES  
(B.P. Y G.N.) Y DISTINTAS FRECUENCIAS (50 Y 60 Hz.)

PLANO

C-1345

ITEM	CODIGO	DENOMINACION	TEXTO	HCG-6/11	HCG-10/11	HCG-10/21	HCG-2-10/11	HCG-6/11A	HCG-10/11A	HCG-10/21A	HCG-2-10/11A				NOTAS
		<b>BUTANO - PROPANO 50 Hz.</b>													
5	T085010	Valvula Honeywell 50Hz. (B.P.)		1	-	-		1	-	-					
5	T115097	Valvula Honeywell 50Hz. (B.P.)		-	1	1		-	1	1					
17	T085013	Arandela regulacion ventilador Ø14		1	-	-		1	-	-					
17	T115082	Arandela regulacion ventilador Ø18		-	1	1		-	1	1					
		<b>BUTANO - PROPANO 60 Hz.</b>													
5	T085016	Valvula Honeywell 60Hz. (B.P.)		1	-	-		1	-	-					
5	T115100	Valvula Honeywell 60Hz. (B.P.)		-	1	1		-	1	1					
17	T085013	Arandela regulacion ventilador Ø14		1	-	-		1	-	-					
17	T115082	Arandela regulacion ventilador Ø18		-	1	1		-	1	1					
		<b>GAS NATURAL 50 Hz.</b>													
5	T085011	Valvula Honeywell 50Hz. (G.N.)		1	-	-		1	-	-					
5	T115098	Valvula Honeywell 50Hz. (G.N.)		-	1	1		-	1	1					
17	T085013	Arandela regulacion ventilador Ø14		1	-	-		1	-	-					
17	T115083	Arandela regulacion ventilador Ø20		-	1	1		-	1	1					
		<b>GAS NATURAL 60 Hz.</b>													
5	T085017	Valvula Honeywell 60Hz. (G.N.)		1	-	-		1	-	-					
5	T115101	Valvula Honeywell 60Hz. (G.N.)		-	1	1		-	1	1					
17	T085013	Arandela regulacion ventilador Ø14		1	-	-		1	-	-					
17	T115083	Arandela regulacion ventilador Ø20		-	1	1		-	1	1					

MOD.

HORNOS A GAS HCG  
HORNOS A GAS VCG ( VAUBAN )

ZONA

SERIGRAFIA PORTAMANDOS ( VAUBAN )

PLANO

C-1339

ITEM	CODIGO	DENOMINACION	TEXTO	HCG-6/11 VCG-6/11	HCG-10/11 VCG-10/11	HCG-10/21 VCG-10/21	HCG-2-10/11 VCG-2-10/11							NOTAS
7	T013030	Serigrafia superior VCG -VAUBAN		1	1	1	1							
8	R723048	Serigrafia inferior VCG -VAUBAN		1	1	1	1							

# HCG-6/11 HCG-10/11 HCG-10/21 HCG-20/11 HCG-20/21

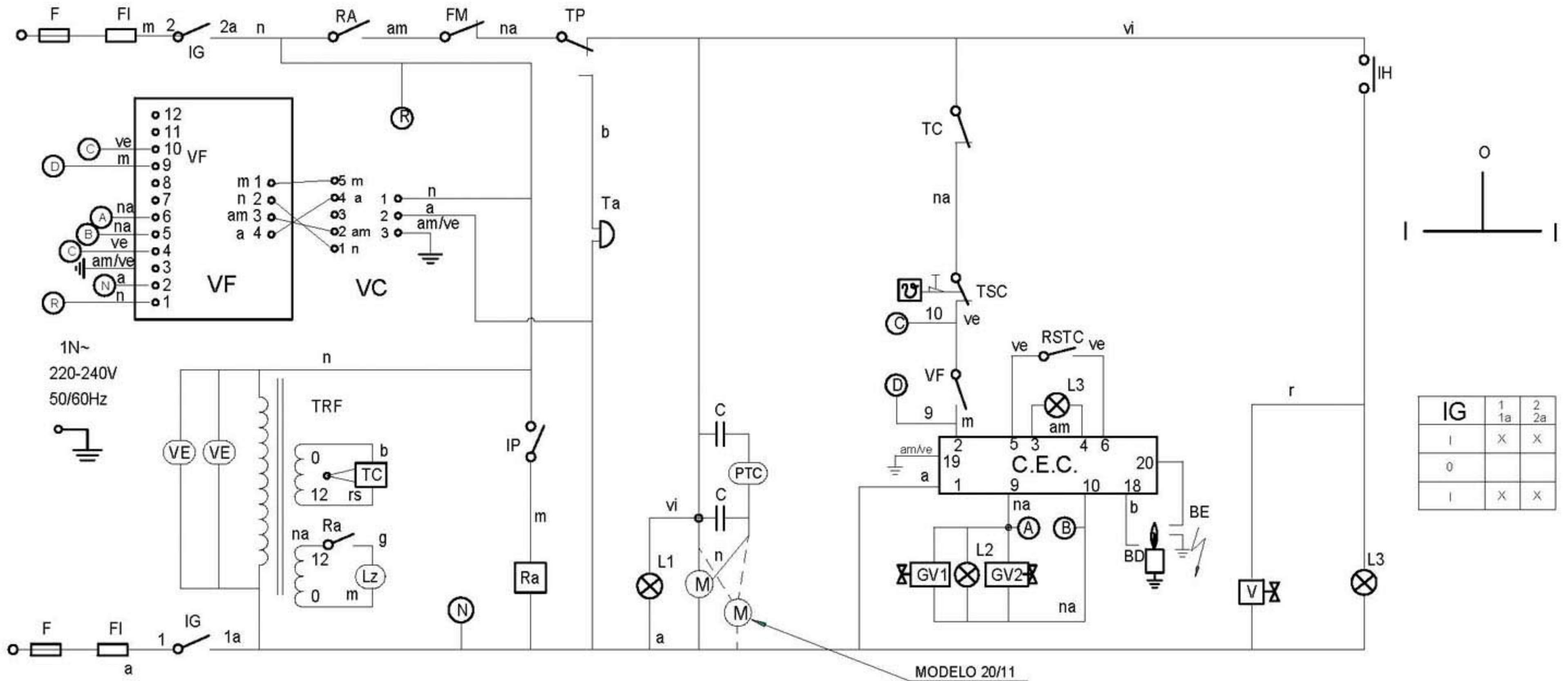

MODELO 20/11

ESQUEMA TEORICO ADHESIVO		T-013044							
Nº	Pieza	Material	Nº Clasificación						
Nº	Modificación	Propuesta de	Fecha						
			Tolerancias generales						
			<table border="0"> <tr> <td>&lt;5±</td> <td>50-100±</td> </tr> <tr> <td>5-25±</td> <td>&gt;100±</td> </tr> <tr> <td>25-50±</td> <td>∞±</td> </tr> </table>	<5±	50-100±	5-25±	>100±	25-50±	∞±
<5±	50-100±								
5-25±	>100±								
25-50±	∞±								
Dibujado	Firma	Fecha	 Fagor Industrial, Koop Elk, Mugatua						
Proyectado	KONTXI	5/6/01							
Comprobado									
Escala	<h2>HORNOS HCG</h2>		Mecanizado superficial  Plano numero <h3>HC-75723</h3>						
Plano hau ez daitake erabil ez berrita gure baimentz gabe			Sustituye al N°  Sustituido por						

# ESPAÑOL

# FRANÇAIS

# ENGLISH

# DEUTSCH

# ITALIANO

## CODIGO DE COLORES:

r = rojo  
a = azul  
m = marrón  
g = gris  
n = negro  
b = blanco  
vi = violeta  
am = amarillo  
na = naranja  
rs = rosa  
ve = verde  
am/ve = amarillo verde

## COMPONENTES:

BD = Bujía de detector de llama  
BE = Bujía de Encendido  
C = Condensador Motor  
**C.E.C. = Control Encendido cámara**  
C.E.V. = Control encendido vapor  
CN = Control nivel de agua  
① F, F1, F2, F3 = Fusible  
FI = Filtro interferencias  
**FM = Térmico Motor**  
**GV1 = Electroválvula de gas cámara (Control)**  
**GV2 = Electroválvula de gas cámara (Seguridad)**  
**GV4 = Electroválvula de gas vapor (Control)**  
**GV5 = Electroválvula de gas vapor (Seguridad)**  
la = Micro chimenea abierta  
lc = Micro chimenea cerrada  
IG = Interruptor general  
IP = Interruptor puerta  
**IR = Selector regulador sonda núcleo**  
**L1 = Lámpara de funcionamiento**  
**L2 = Lámpara calentamiento cámara**  
**L4 = Lámpara entrada de vapor**  
**L3 = Lámpara indicador de bloqueo cámara**  
**L5 = Lámpara indicador de bloqueo vapor**  
**L6 = Lámpara seguridad de vapor**  
**L7 = Lámpara detección de cal**  
**Lz = Luz interior cámara**  
M = Motor  
M1 = Motor accionamiento chimenea  
**R2, R1, Ra = Relé Auxiliar**  
**RE1 = Regulador de energía**  
**RSTC = Pulsador de rearme cámara**  
RSTV = Pulsador de rearme vapor  
**RTS = Regulador sonda núcleo**  
T100 = Termostato fijo 100°C  
Ta = Timbre avisador  
**TC = Termostato cámara**  
**TCN = Termostato condensación**  
**TDC = Termostato detección de cal**  
① TP, TMP = Temporizador  
① TRF, TRF1 = Transformador  
**TSC = Termostato seguridad cámara**  
TSV = Termostato seguridad de vapor  
TV = Termostato de vapor  
**V1 = Electroválvula de agua de llenado**  
VC = Ventilador centrifugo premezcla  
**VCN = Electroválvula de agua de condensación**  
**VE = Ventilador cuadro eléctrico**  
VF = Variador de frecuencia

## CODES DE COULEURS:

r = rouge  
a = bleu  
m = marron  
g = gris  
n = noir  
b = blanc  
vi = violet  
am = jaune  
na = orange  
rs = rose  
ve = vert  
am/ve = jaune/vert

## COMPOSANTS:

**BD = Veilleuse de détection de flamme**  
BE = Veilleuse d'allumage  
C = Condensateur moteur  
C.E.C. = Contrôle d'allumage de chambre  
C.E.V. = Contrôle d'allumage de vapeur  
CN = Contrôle du niveau d'eau  
① F, F1, F2, F3 = Fusible  
**FI = Filtre interférences**  
FM = Moteur thermique  
GV1 = Electrovalve de chambre gaz (contrôle)  
**GV2 = Electrovalve de chambre gaz (sécurité)**  
GV4 = Electrovalve de vapeur gaz (contrôle)  
**GV5 = Electrovalve de vapeur gaz (sécurité)**  
**la = Micro cheminée ouverte**  
**lc = Micro cheminée fermée**  
IG = Interrupteur général  
IP = Interrupteur de porte  
**IR = Sélecteur régulateur de sonde noyau**  
L1 = Lampe de fonctionnement  
L2 = Lampe de chauffe chambre  
**L4 = Lampe d'arrivée de vapeur**  
**L3 = Lampe témoin de blocage de chambre**  
**L5 = Lampe témoin de blocage de vapeur**  
**L6 = Lampe de sureté de vapeur**  
**L7 = Lampe de détection de calcaire**  
**Lz = LumiÈre intérieure de chambre**  
M = Moteur  
**M1 = Actionnement moteur de cheminée**  
R2, R1, Ra = Relais auxiliaire  
**RE1 = Régulateur d'énergie**  
**RSTC = Bouton de réarmement de chambre**  
**RSTV = Bouton de réarmement de vapeur**  
**RTS = Régulateur de sonde noyau**  
T100 = Thermostat fixe 100°C  
Ta = Sonnerie d'alarme  
TC = Thermostat de chambre  
TCN = Thermostat de condensation  
**TDC = Thermostat de détection de calcaire**  
① TP, TMP = Temporisateur 0-120  
① TRF, TRF1 = Transformateur  
**TSC = Thermostat de sureté de chambre**  
TSV = Thermostat de sureté de vapeur  
TV = Thermostat de vapeur  
V1 = Electrovalve de remplissage d'eau  
**VC = Ventilateur de centrifugeuse de prémélange**  
VCN = Electrovalve de condensation d'eau  
VE = Ventilateur tableau électrique  
VF = Variador de frecuencia

## COLOUR CODE

r = red  
a = blue  
m = brown  
g = grey  
n = black  
b = white  
vi = violet  
am = yellow  
na = orange  
rs = pink  
ve = green  
am/ve = yellow-green

## COMPONENTS:

BD = Flame detector spark plug  
BE = Ignition spark plug  
C = Motor condenser  
C.E.C. = Cooking chamber ignition control  
C.E.V. = Steam ignition control  
CN = Water level control  
① F, F1, F2, F3 = Fusible  
FI = Interference filter  
FM = Motor thermal switch  
Cooking chamber gas solenoid valve (control)  
GV2 = Cooking chamber gas solenoid valve (safety)  
GV4 = Steam gas solenoid valve (control)  
GV5 = Steam gas solenoid valve (safety)  
la = Chimney open microswitch  
lc = Chimney closed microswitch  
IG = Interruptor general  
IP = Door switch  
IR = Core probe regulator selector  
L1 = On/off lamp  
L2 = Cooking chamber heating lamp  
L4 = Steam inlet lamp  
L3 = Cooking chamber lock indicator lamp  
L5 = Steam lock indicator lamp  
L6 = Steam safety lamp  
L7 = Lime detection lamp  
Lz = Cooking chamber interior lamp  
M = Motor  
M1 = Chimney drive motor  
R2, R1, Ra = Auxiliary relay  
RE1 = Energy regulator  
RSTC = Cooking chamber reset button  
RSTV = Steam reset button  
RTS = Core probe regulator  
T100 = Fixed 100°C thermostat  
Ta = Warning buzzer  
TC = Cooking chamber thermostat  
TCN = Condensation thermostat  
TDC = Lime detection thermostat  
① TP, TMP = 0-120 timer  
① TRF, TRF1 = Transformer  
TSC = Cooking chamber safety thermostat  
TSV = Steam safety thermostat  
TV = Steam thermostat  
V1 = Water filling solenoid valve  
VC = Pre-mix centrifuge fan  
VCN = Condensation water solenoid valve  
VE = Switchboard fan  
VF = Frequency inverter

## FARBENCODE

r = rot  
a = blau  
m = braun  
g = grau  
n = schwarz  
b = weiss  
vi = violett  
am = gelb  
na = orangers  
rs = rosa  
ve = grün  
am/ve = gelb/grün

## KOMPONENTEN:

BD = Zündkerze des Flammendetektors  
BE = Zündkerze der Zündung  
C = Motorkondensator  
C.E.C. = Zündkontrolle Kammer  
C.E.V. = Zündkontrolle Dampf (Kontrolle)  
CN = Kontrolle Wasserstand  
① F, F1, F2, F3 = Fusible  
FI = Interferenzefilter  
FM = Thermomoter  
GV1 = Electroventil Gas, Kammer (Kontrolle)  
GV2 = Electroventil Gas, kammer (Sicherheit)  
GV4 = Electroventil Gas, Dampf (Kontrolle)  
GV5 = Electroventil Gas, Dampf (Sicherheit)  
la = Mikroschacht geöffnet  
lc = Mikroschacht geschlossen  
IG = Hauptschalter  
IP = Turschalter  
IR = Wahlregler Kernsonde  
L1 = Funktionsleuchtanzeige  
L2 = Erwärmungsleuchtanzeige Kammer  
L4 = Leuchtanzeige Dampfeintritt  
L3 = Leuchtanzeige Blockierung Kammer  
L5 = Leuchtanzeige Blockierung Dampf  
L6 = Sicherheitsleuchtanzeige Dampf  
L7 = Kalkanzeige  
Lz = Innenbeleuchtung Kammer  
M = Motor  
M1 = Motorantrieb Mikroschacht  
**R2, R1, Ra = Relé Auxiliar**  
RE1 = Hilfsrelais  
RSTC = Bedienungstaste Durch, Aufladung Kammer  
RSTV = Bedienungstaste Durch, Aufladung Dampf  
RTS = Kernsondenregler  
T100 = Thermostat auf 100°C  
Ta = Meldeklöngel/Lautwerk  
TC = Thermostat Kammer  
TCN = Kondensationsthermostat  
TDC = Thermostat Kalkanzeige  
① TP, TMP = Zeitschalter 0-120  
① TRF, TRF1 = Transformator  
TSC = Sicherheitsthermostat Kammer  
TSV = Sicherheitsthermostat Dampf  
TV = Dampftthermostat  
V1 = Elektroventil Wasserfüllung  
VC = Zentrifugallüfter Vormischung  
VCN = Elektroventil Kondenswasser  
VE = Schalttafelventilator  
VF = Frequenzwandler

## CODICE DEI COLORI:

r = rosso  
a = azzurro  
m = marrone  
g = grigio  
n = nero  
b = bianco  
vi = viola  
am = giallo  
na = arancione  
rs = rosa  
ve = verde  
am/ve = giallo/verde

## COMPONENTI:

BD = Candela del rilevatore di fiamma  
BE = Candela d'accensione  
C = Condensatore motore  
C.E.C. = Controllo accensione cabina  
C.E.V. = Controllo accensione vapore (controllo)  
CN = Controllo livello d'acqua  
① F, F1, F2, F3 = Fusibile  
FI = Filtro interferenze  
FM = Termico Motore  
GV1 = Elettrovalvola gas cabina (controllo)  
GV2 = Elettrovalvola gas cabina (sicurezza)  
GV4 = Elettrovalvola gas vapore (controllo)  
GV5 = Elettrovalvola gas vapore (sicurezza)  
la = Micro camino aperto  
lc = Micro camino chiuso  
IG = Interruttore generale  
IP = Interruttore porta  
IR = Selettore regolatore sonda nucleo  
L1 = Lampadina di funzionamento  
L2 = Lampadina riscaldamento cabina  
L4 = Lampadina ingresso vapore  
L3 = Lampadina indicatore di blocco cabina  
L5 = Lampadina indicatore di blocco vapore  
L6 = Lampadina di sicurezza vapore  
L7 = Lampadina rilevatore di calcare  
Lz = Luce interna cabina  
M = Motore  
M1 = Motore funzionamento camino  
R2, R1, Ra = Relais ausiliario  
**RE1 = Regolatore d'energia**  
RSTC = Pulsante di riarmo vapore  
RSTV = Regolatore sonda nucleo  
RTS = Regolador Sonda Nucleo  
T100 = Termostato fijo 100°C  
Ta = Campanello avvisatore  
TC = Termostato cabina  
TCN = Termostato condensazione  
TDC = Termostato rilevatore di calcare  
① TP, TMP = Timer 0-120  
① TRF, TRF1 = Transformador  
TSC = Termostato sicurezza cabina  
TSV = Termostato sicurezza vaspore  
TV = Termostato vapore  
V1 = Elettrovalvola acqua di riempimento  
VC = Ventilatore centrifuga  
VCN = Elettrovalvola acqua di condensazione  
VE = Ventilatore quadro elettrico  
VF = Variatore di frequenza



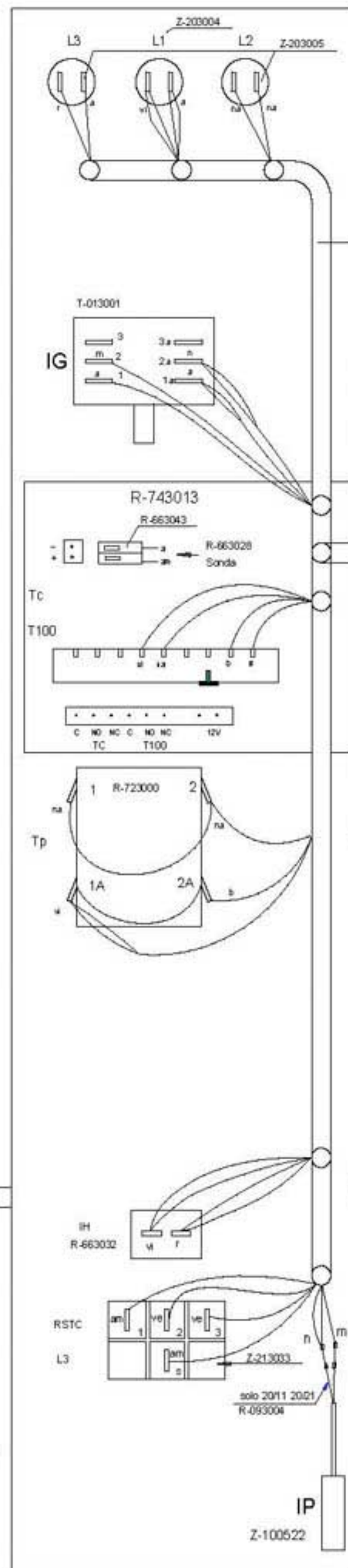
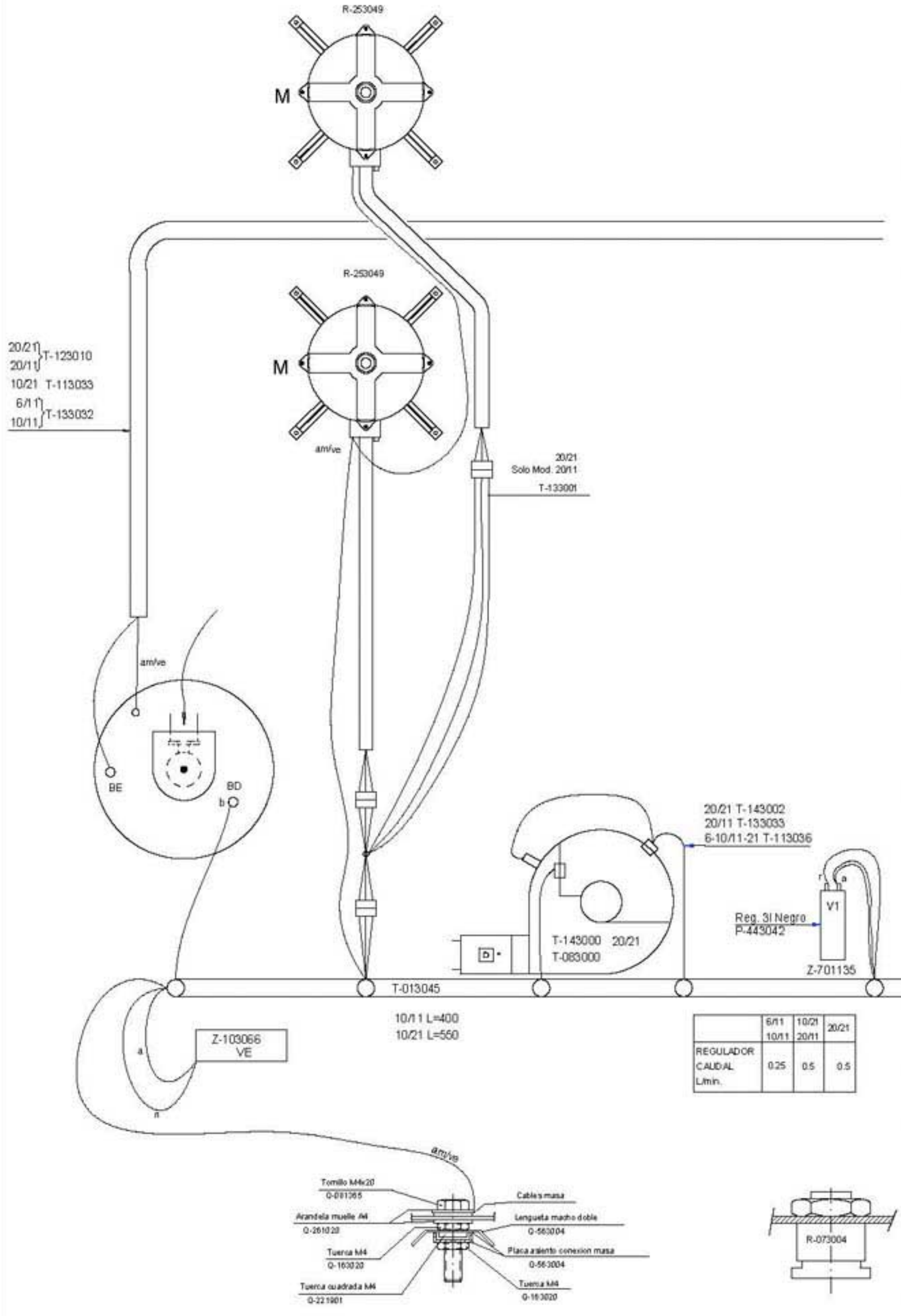

- r= rojo - red - rouge
- m= marrón - brown - marrón
- g= gris - grey - gris
- n= negro - black - noir
- a= azul - blue - bleu
- b= blanco - white - blanc
- vi= violeta - violette - violet
- am= amarillo - yellow - jaune
- na= naranja - orange - orange
- rs= rosa - rose - pink
- ve= verde - green - vert
- am/ve= amarillo/verde - yellow/green - jaune/vert

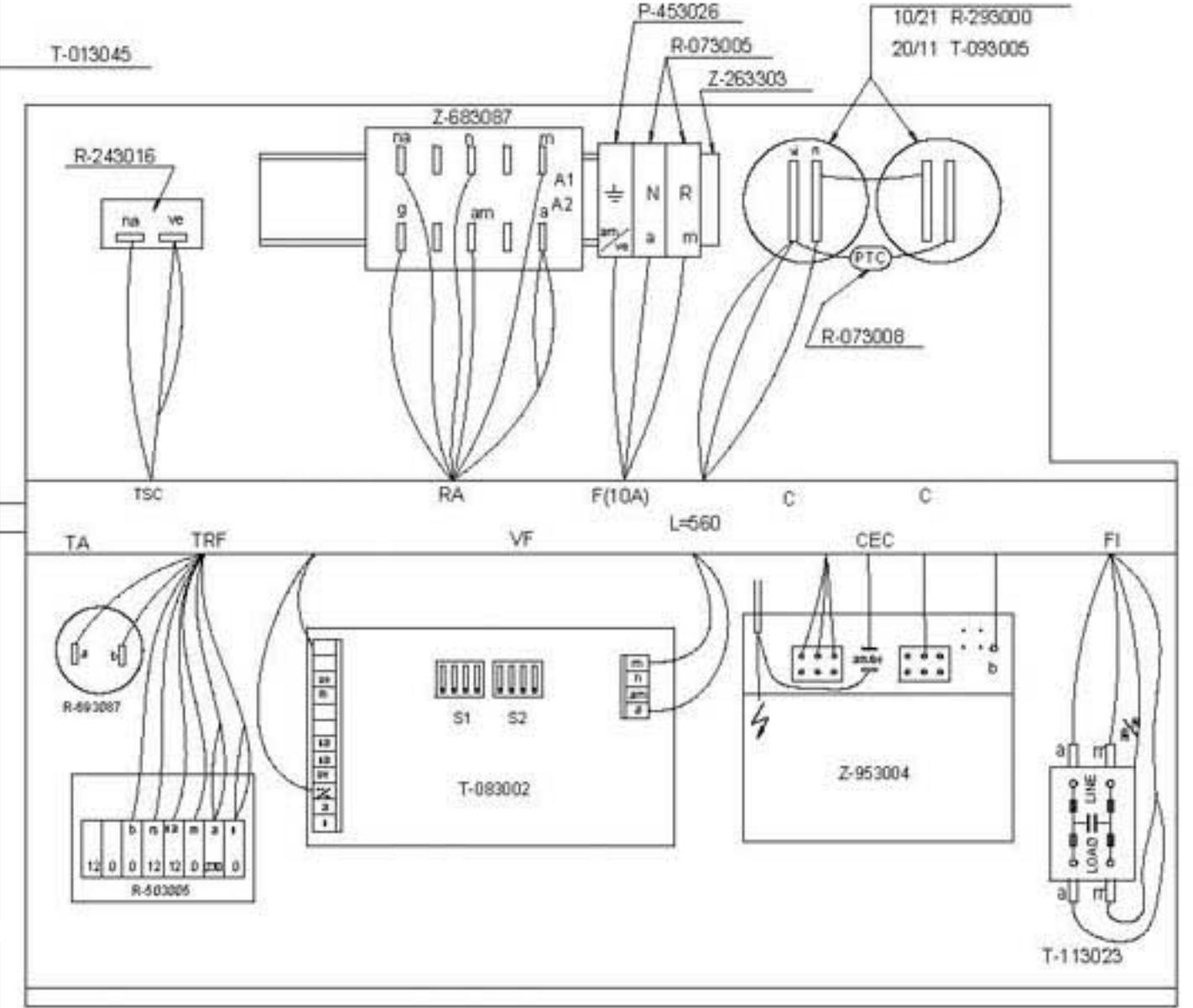

ESQUEMA T-013044  
LEYENDA T-113028  
INDICADOR COMPONENTES T-083038

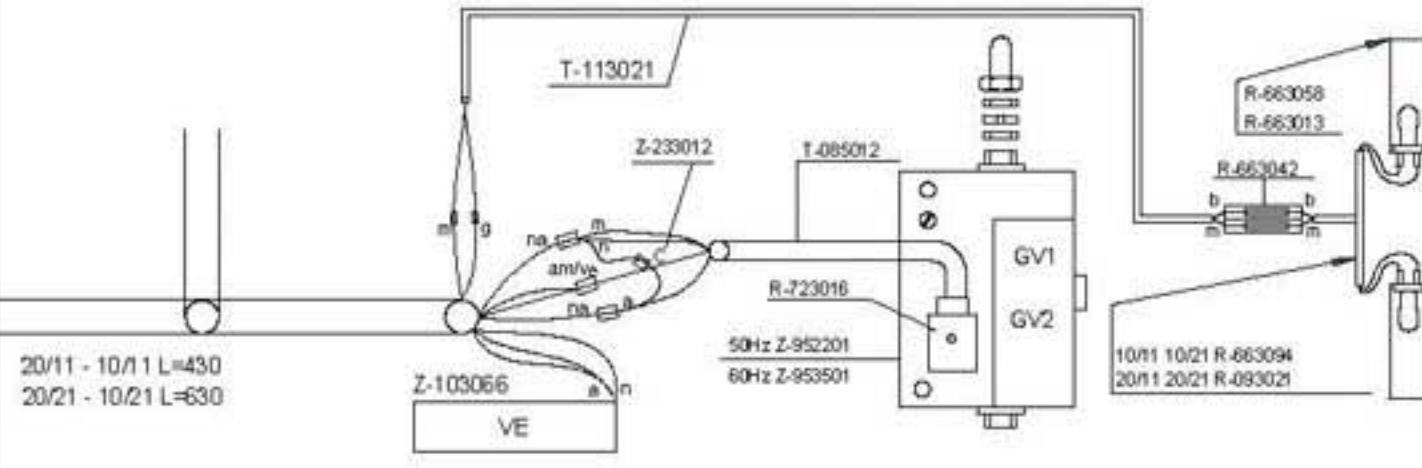

Esquema de montaje HCG			T-013046			
Nº	Pieza	Carri.	Materia	Nº Clasificación	Acabado	
Nº	Modificación		Propuesta de	Fecha	Tolerancias generales	
					<math>\leq \pm</math>	50-100%
					5-25%	>100%
					25-50%	<math>\infty \pm</math>

Firma	Fecha	 Fagor Industrial Koop. Elk., Mugatua	Mecarizado superficial  Plano numero <b>HD-12792</b> Sustituye al Nº Sustituido por	
Dibujado	KONTXI			26.01
Proyectado				
Comprobado				
Escala				

HORNOS HCG

Plano numero HD-12792

Sustituye al Nº

Sustituido por