

**Hornos Mixtos a Gas con Caldera
Fours Mixtes à Gaz avec Chaudière
Gas Combi Ovens with Steam Generator
Gas-HeiBluftdämpfer
Forni Misti con Boiler a Gas**

Modelos:

**HVG-20/21
HVG-2-20/11**

**VGT-20/21
VGT-2-20/11**

Mayo 2003 May



Fagor Industrial

MOD.		HORNOS A GAS HVG			ZONA	MUEBLE						PLANO	C-1328
ITEM	CODIGO	DENOMINACION	TEXTO	HVG-20/21									NOTAS
1	T122810	Posterior de camara colector		1									
	Q412002	Remache tubular Ø4x7,5		12									
2	T112815	Soporte chimenea		4									
	Q412002	Remache tubular Ø4x7,5		12									
3	T122820	Chimenea exterior completa		1									
4	T142817	Salida de colector copleta		1									
	Q221342	Remache exagonal M-5		4									
	Q232030	Arandela plana A-5		4									
	Q012031	Tornillo exagonal M-5x10		4									
5	T142812	Posterior de colector		1									
6	T122807	Anterior de colector		1									
	Q221342	Remache exagonal M-5		28									
	Q152004	Tornillo aplastado M-5x13		28									
7	T122809	Anterior de camara colector		1									
	Q412002	Remache tubular Ø4x7,5		18									
8	3715200	Junta de estanqueidad L=2600		1									
9	T142815	Bandeja de colector completa		1									
	Q412002	Remache tubular Ø4x7,5		23									
10	T142804	Panel lateral derecho		1									
11	T142803	Panel superior		1									
	Q221343	Remache exagonal M-6		2									
	Q232040	Arandela plana A-6		2									
	Q262040	Arandela muelle A-6		2									
	Q012042	Tornillo exagonal M-6x15		2									
	Q152017	Tornillo amarre M-6x13		7									
12	T112821	Canaleta portamandos		1									
13	T132823	Junta superior portamandos		1									
14	T132637	Protector de portamandos		1									
	Q412002	Remache tubular Ø4x7,5		6									

MOD.		HORNOS A GAS HVG			ZONA	MUEBLE						PLANO	C-1328
ITEM	CODIGO	DENOMINACION	TEXTO	HVG-20/21									NOTAS
15	3715400	Junta panel portamandos L=1400		1									
16	T113014	Serigrafia portamandos HVG		1									
17	T132825	Panel portamandos		1									
	Q221343	Remache exagonal M-6		4									
	Q232040	Arandela plana A-6		4									
	Q262040	Arandela muelle A-6		4									
	Q012042	Tornillo exagonal M-6x15		4									
18	Z952911	Soporte limitador aviso		1									
	Q242030	Arandela abanico A-5		2									
	Q162030	Tuerca exagonal M-5		2									
19	T112812	Soporte componentes		1									
	Q152004	Tornillo aplastado M-5x13		2									
20	3715400	Junta panel portamandos L=1400		1									En panel lateral
21	T142807	Panel lateral izquierdo		1									
	Q221343	Remache exagonal M-6		2									
	Q232040	Arandela plana A-6		2									
	Q262040	Arandela muelle A-6		2									
	Q012042	Tornillo exagonal M-6x15		2									
22	R095006	Flexible de ducha		1									
23	-	Arandela junta (con cuerpo ducha)		2									
24	T145025	Suplemento ducha		1									
	Q012042	Tornillo exagonal M-6x15		2									
25	R095007	Soporte de ducha		1									
	Q221342	Remache exagonal M-4		3									
	Q042022	Tornillo avellanado M-4x15		3									
26	R095005	Cuerpo de ducha		1									
27	T142808	Panel lateral izquierdo posterior		1									
	Q012042	Tornillo exagonal M-6x15		4									
	Q262040	Arandela muelle A-6		4									

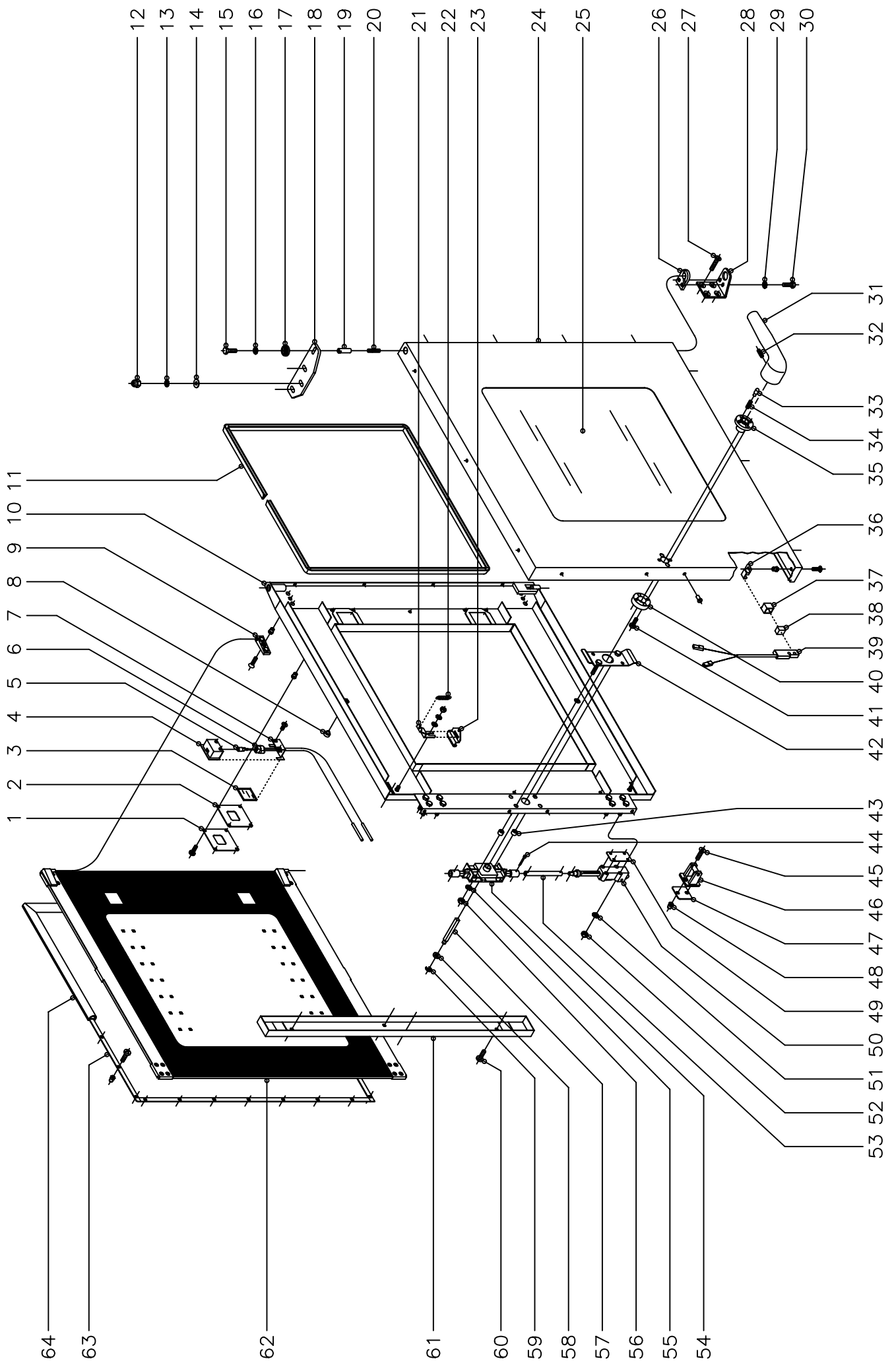

N plano
C-1329

Firma
[Signature]

Fecha
5-2003

Aparato
PUERTA
HORNO A GAS HVG-20/21

Lamina
2

Fagor Industrial S.Coop. **FAGOR**
Onate

MOD.		HORNOS A GAS HVG			ZONA	PUERTA						PLANO	C-1329
ITEM	CODIGO	DENOMINACION	TEXTO	HVG-20/21									NOTAS
	1100002598	KIT Puerta completa 20/21		1									
1	R670608	Tapa cierre lampara		2									
	Q032021	Tornillo alomado M-4x10		8									
	Q222041	Remache exagonal M-4		8									
2	R670609	Junta cierre lampara		2									
3	R670618	Cristal de lampara		2									
4	R670610	Deflector de lampara		2									
5	R663013	Lampara 10 W. 12 V.		2									
6	R663058	Portalamparas		2									
7	R670611	Suplemento deflector		2									
	Q042031	Tornillo avellanado M-5x10		4									
8	R670617	Tope cristal interior		8									
9	R670615	Base de bisagra		2									
	Q042032	Tornillo avellanado M-5x15		2									
	Q222011	Remache exagonal M-5		2									
10	T140500	Contrapuerta completa 20/21		1									
11	3715200	Junta cristal L=3500		1									
12	Q212051	Tuerca sombrerete M-8		3									
13	Q242050	Arandela abanico A-8		3									
14	Q302025	Arandela plana Ø8,4xØ20x1,5		3									
15	Q012042	Tornillo exagonal M-6x15		1									
16	Q242040	Arandela abanico A-6		1									
17	R662807	Arandela amarre puerta		1									
18	T130500	Bisagra superior		1									
19	R660534	Eje superior		1									
20	Z850519	Resorte		1									
21	R670612	Base de pestillo		2									
	Q302022	Arandela plana Ø16xØ6x1,2		2									

MOD.	HORNOS A GAS HVG	ZONA	PUERTA	PLANO	C-1329
------	-------------------------	------	---------------	-------	---------------

ITEM	CODIGO	DENOMINACION	TEXTO	HVG-20/21										NOTAS
	Q242040	Arandela abanico A-6		2										
	Q162040	Tuerca exagonal M-6		2										
22	R660605	Muelle tensor pestillo		2										
23	R670613	Pestillo sujecion cristal interior		2										
24	R140600	Panel puerta 20/21		1										
	Q412002	Remache tubular Ø4x7,5		16										
25	R140604	Cristal exterior 20/21		1										
26	R660549	Guia eje inferior		1										
27	Q062040	Tornillo avellanado M-6x16		4										
28	R660551	Bisagra inferior		1										
29	Q242040	Arandela abanico A-6		2										
30	Q012041	Tornillo exagonal M-6x10		2										
31	T130502	Manilla		1										
32	Q132042	Varilla roscada M-6x15		1										
33	T130507	Piton enganche		2										
34	T130506	Resorte		2										
35	T130515	Guia manilla		1										
36	T130513	Soporte iman		1										
37	Z200507	Protector iman		1										
38	Z200506	Iman		1										
39	Z100522	Interruptor magnetico		1										
40	T130514	Soporte resortes		1										
41	Q032032	Tornillo alomado M-5x15		2										
42	T130511	Suplemento fijacion cerradura		1										
43	Z608410	Casquillo		2										
44	Q352001	Pasador de aletas Ø2x15		4										
45	Q042043	Tornillo avellanado M-6x20		4										
46	R260545	Enganche		2										
47	R660538	Calzo de enganche		6										

MOD.		HORNOS A GAS HVG			ZONA	PUERTA						PLANO	C-1329
ITEM	CODIGO	DENOMINACION	TEXTO	HVG-20/21									NOTAS
48	Q221343	Remache exagonal M-6		4									
49	T080503	Suplemento elemento cierre		6									
50	T080504	Elemento de cierre		2									
51	Q262040	Arandela muelle A-6		8									
52	Q162040	Tuerca exagonal M-6		8									
53	R090514	Tubo alargadera		2									
54	T130509	Mecanismo de cierre		1									
55	Q262040	Arandela muelle A-6		2									
56	Q162040	Tuerca exagonal M-6		2									
57	T130508	Eje de manilla		1									
58	T130505	Casquillo		1									
59	Q271033	Arandela de seguridad Ø6		1									
60	Q032031	Tornillo alomado M-5x10		2									
60	Q032021	Tornillo alomado M-4x10		2									
61	T140502	Tapa cierre puerta		1									
62	1100002810	KIT Cristal interior complet. 20/21		1									
63	R140507	Fijacion junta completa 20/21		1									
	Q033021	Tornillo alomado M-4x10 (laton)		40									
	Q222041	Remache exagonal M-4 inox.		40									
64	R140506	Junta de puerta 20/21		1									

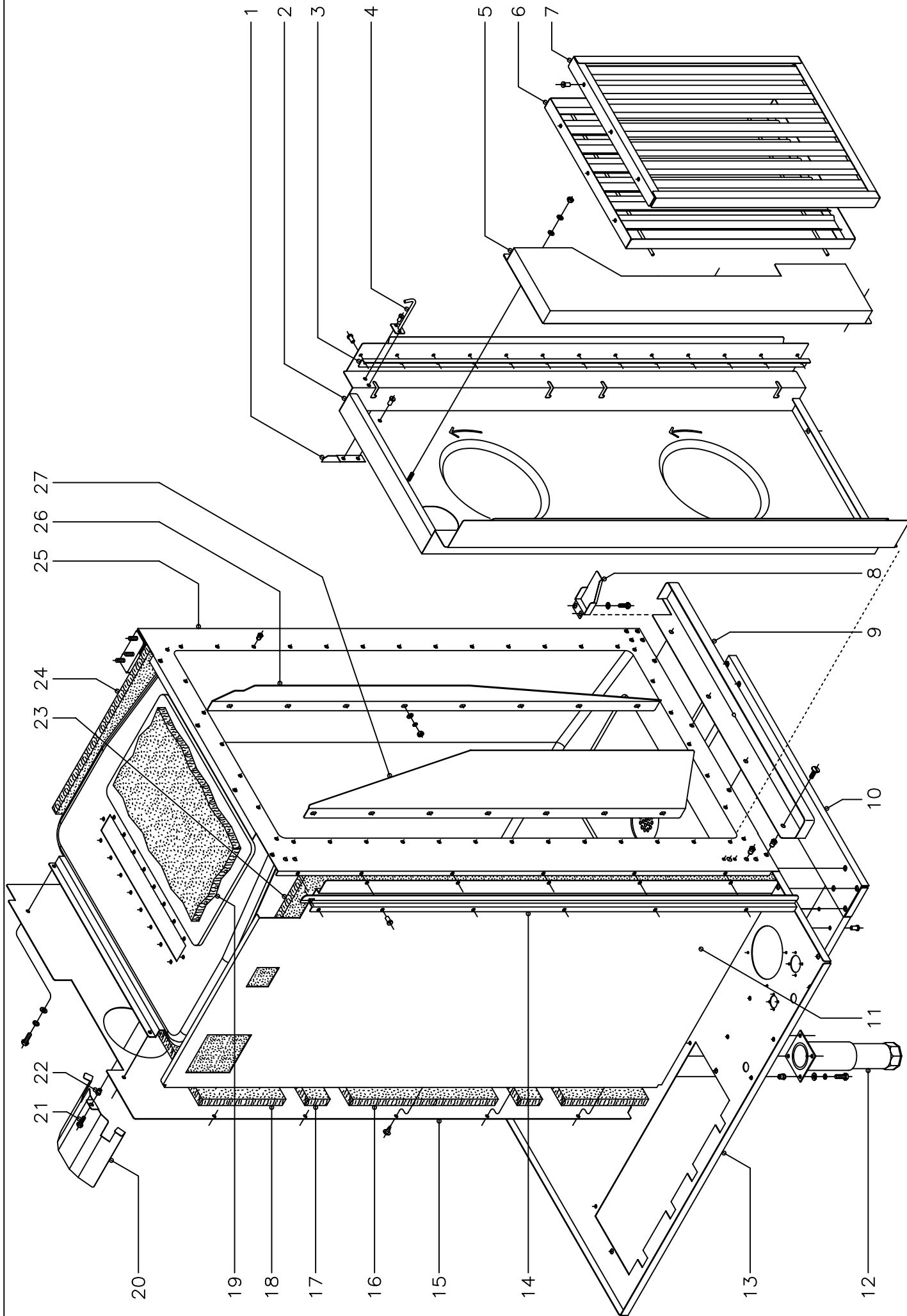

N plano C-1330	Firma 	Fecha 5-2003	Aparato MUEBLE INTERIOR HORNO A GAS HVG-20/21	Lamina 3	Fagor Industrial S.Coop. FAGOR  Onate
-------------------	--	-----------------	---	-------------	--

MOD.	HORNOS A GAS HVG	ZONA	MUEBLE INTERIOR	PLANO	C-1330
------	-------------------------	------	------------------------	-------	---------------

ITEM	CODIGO	DENOMINACION	TEXTO	HVG-20/21										NOTAS
1	R292647	Escuadra sujecion cubreventilador		2										
	Q412002	Remache tubular Ø 4x7,5		4										
2	T152611	Cubre ventilador		1										
3	R092616	Tope cubreventilador		2										
	Q412002	Remache tubular Ø 4x7,5		26										
4	R142615	Fijacion portabandejas		2										
	Q412002	Remache tubular Ø 4x7,5		4										
5	T142627	Conduccion de humos completa		1										
	Q232030	Arandela plana A-5		3										
	Q242030	Arandela abanico A-5		3										
	Q162030	Tuerca exagonal M-5		3										
6	R092621	Posterior de filtro		2										
	R092618	Anterior de filtro		2										
8	Q412002	Remache tubular Ø 4x7,5		12										
	R662800	Cubrecables		1										
	Q221342	Remache exagonal M-5		2										
	Q232030	Arandela plana A-5		2										
	Q012031	Tornillo exagonal M-5x10		2										
	T142820	Recogeaguas		1										
9	Q221343	Remache exagonal M-6		4										
	Q152017	Tornillo amarre M-6x13		4										
	T152801	Refuerzo de apoyos		1										
10	Q412002	Remache tubular Ø 4x7,5		28										
	T152604	Soporte lateral aislante		1										
12	R092830	Pata regulable		4										
	Q012043	Tornillo exagonal M-6x20		16										
	Q262040	Arandela muelle A-6		16										
	Q232040	Arandela plana A-6		16										
	Q221343	Remache exagonal M-6		16										

MOD.		HORNOS A GAS HVG			ZONA	MUEBLE INTERIOR						PLANO	C-1330
ITEM	CODIGO	DENOMINACION	TEXTO	HVG-20/21									NOTAS
13	T142800	Base exterior de horno		1									
14	T132637	Protector de portamandos		1									
	Q412002	Remache tubular Ø 4x7,5		6									
15	T142608	Soporte aislante posterior		1									
	Q151301	Tornillo alomado		5									
	Q012042	Tornillo exagonal M-6x15		15									
	Q262040	Arandela muelle A-6		15									
	Q232040	Arandela plana A-6		15									
16	U675605	Aislante central 740x380x20		1									
17	R662616	Aislante entre refuerzos 560x60x20		8									
18	R032625	Aislante supe. e inferi. 760x230x20		2									
19	R682623	Aislante base y techo 860x790x20		6									
20	R142628	Tejadillo motor turbina		2									
s/n	R142614	Tejadillo ventilador soplante		1									
21	Q012042	Tornillo exagonal M-6x15		5									
22	Q221343	Remache exagonal M-6		5									
23	R142608	Aislante lateral 1370x860x20		3									
24	R142608	Aislante lateral 1370x860x20		2									
25	T142600	Cuerpo interior horno		1									
26	T152617	Deflector derecho de horno		1									
27	T152616	Deflector izquierdo de horno		1									
	Q232040	Arandela plana A-6		15									
	Q262040	Arandela muelle A-6		15									
	Q162040	Tuerca exagonal M-6		15									

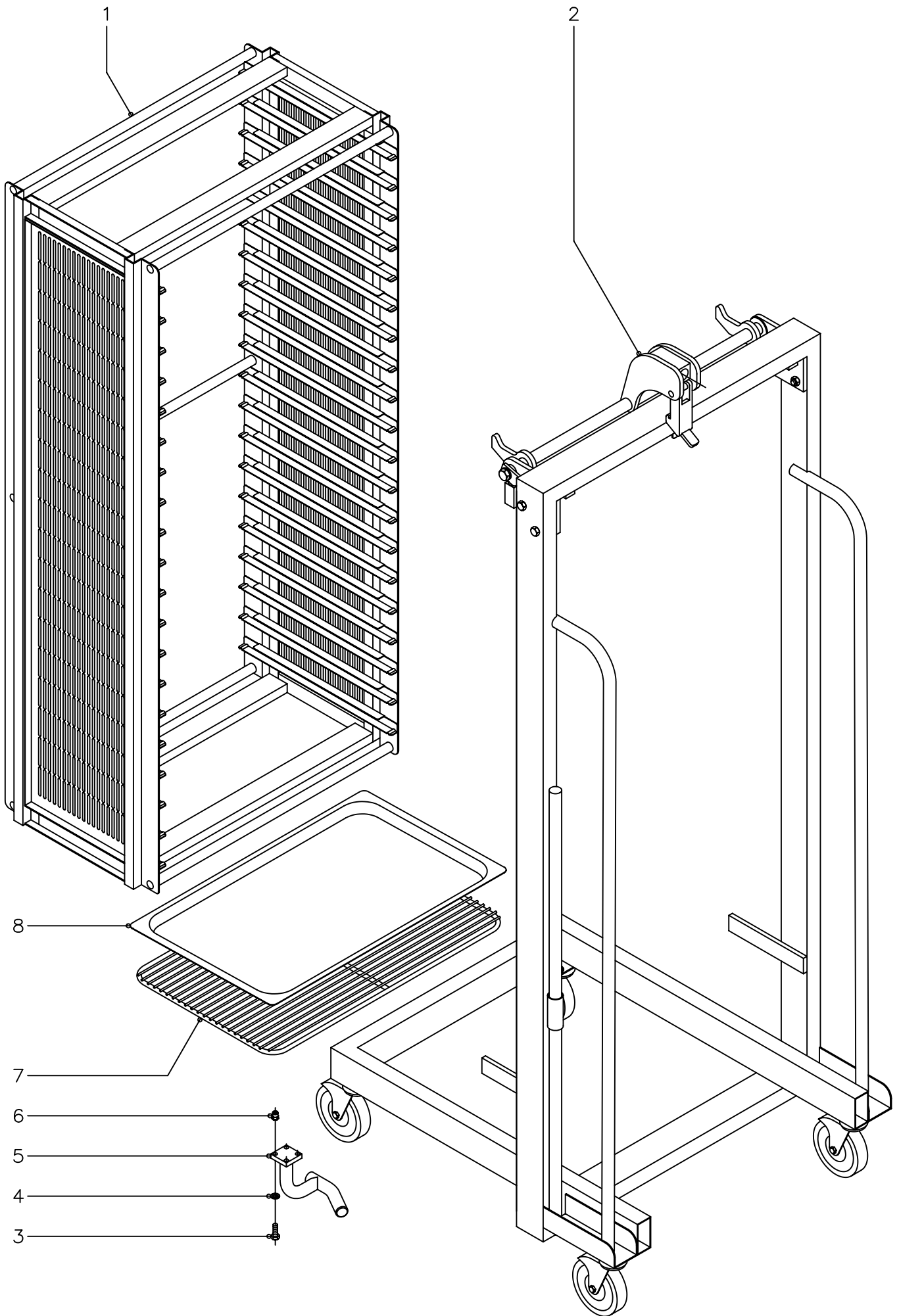

N plano
C-1331

Firma
[Signature]

Fecha
5-2003

Aparato CARRO Y ESTRUCTURA PORTABANDEJAS
HORNO A GAS HVG-20/21

Lamina
4

Fagor Industrial S.Coop. **FAGOR** 
Oferte

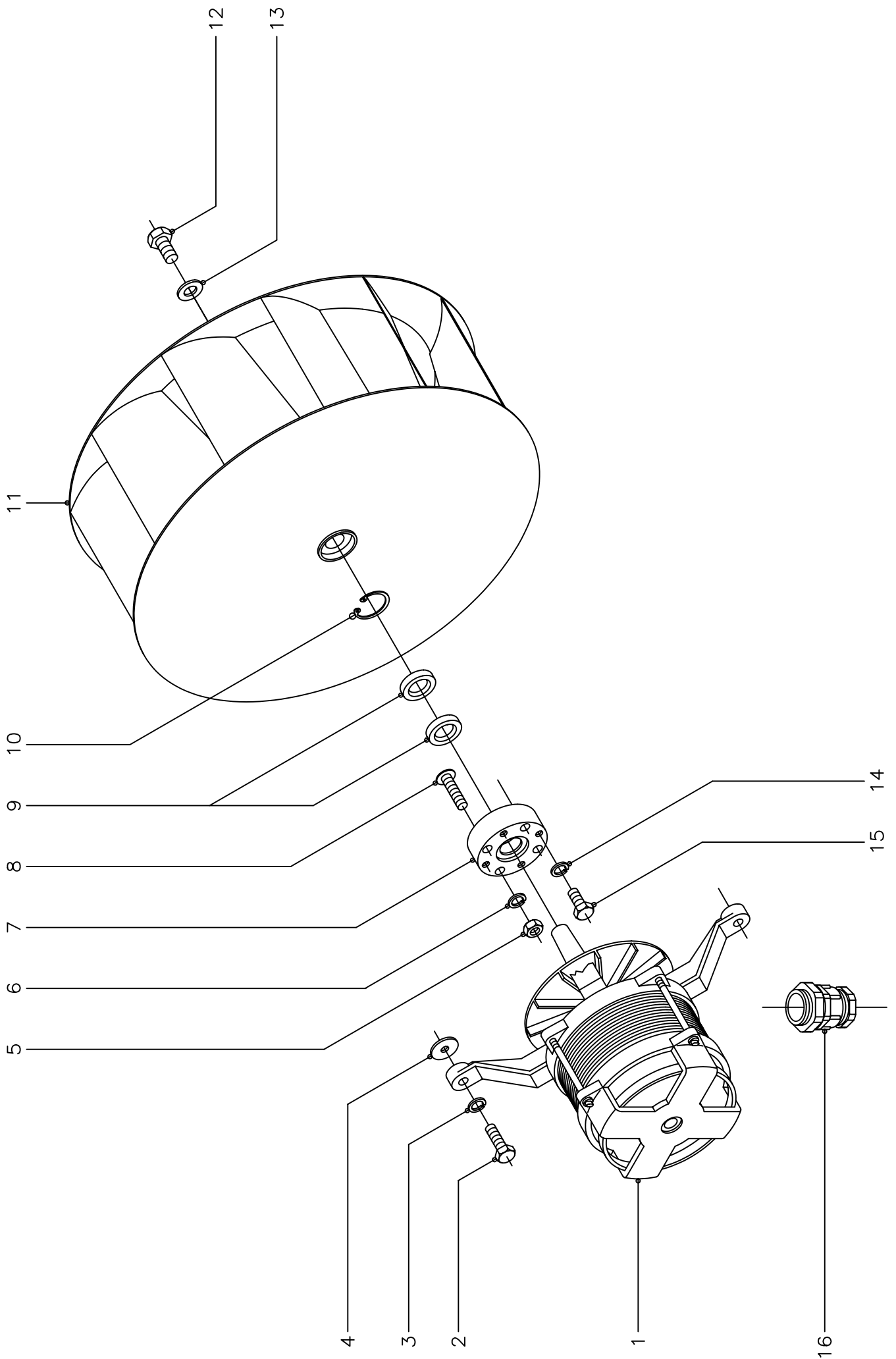

N plano C-1332	Firma 	Fecha 5-2003	Aparato TURBINA HORNO A GAS HVG-20/21	Lamina 5	Fagor Industrial S.Coop. FAGOR Oñate
-------------------	-----------	-----------------	---	-------------	--

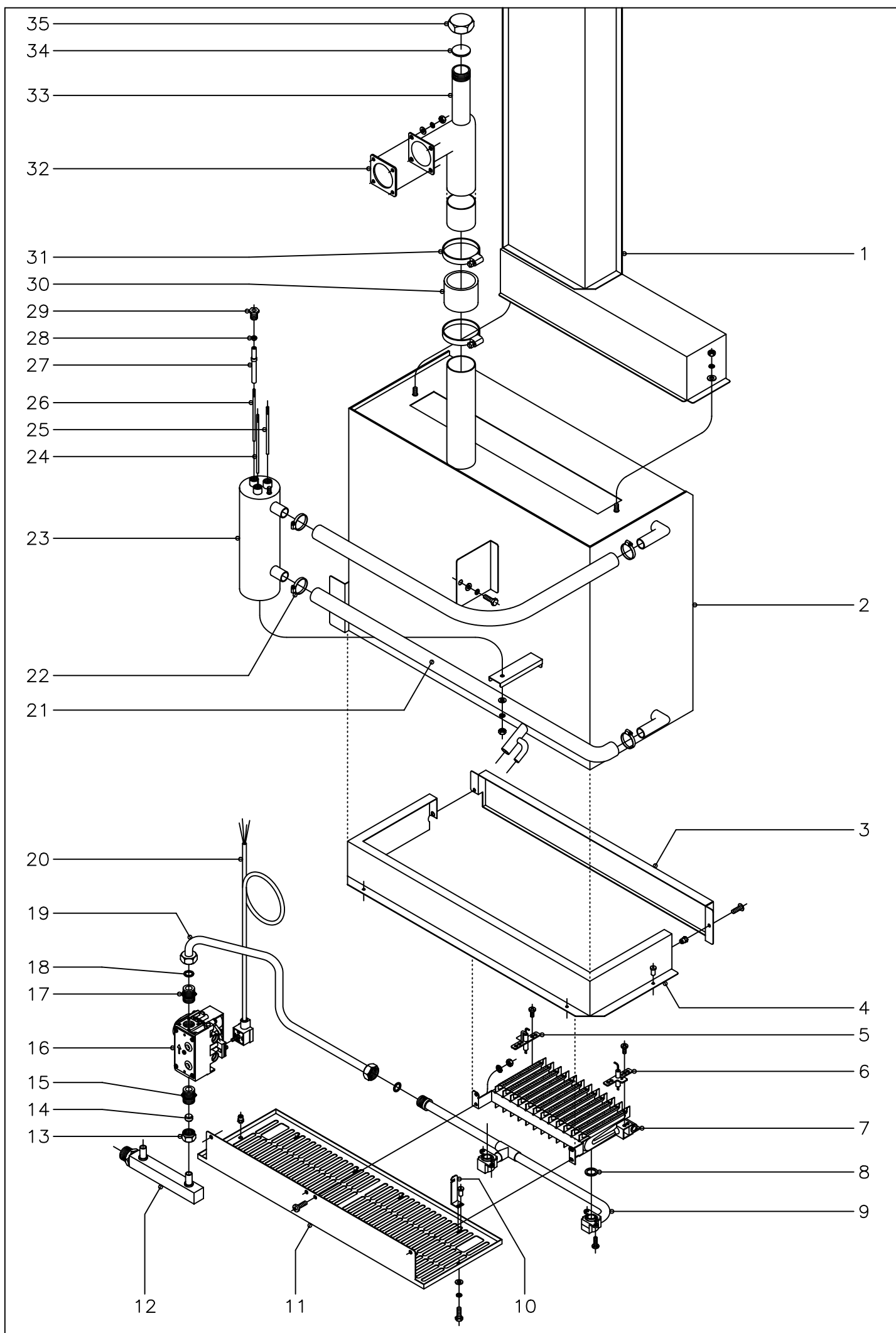

N plano C-1333	Firma 	Fecha 5-2003	Aparato GENERADOR DE VAPOR HORNO A GAS HVG-20/21	Lamina 6	Fagor Industrial S.Coop. FAGOR  Onate
-------------------	--	-----------------	--	-------------	--

MOD.		HORNOS A GAS HVG		ZONA	GENERADOR DE VAPOR							PLANO	C-1333
ITEM	CODIGO	DENOMINACION	TEXTO	HVG-20/21								NOTAS	
1	T142623	Chimenea generador completa		1									
	T145045	Aislante anterior de chimenea		1									
	T145044	Aislante posterior de chimenea		1									
	T145043	Aislante inferior de chimenea		1									
	Q302022	Arandela plana Ø16xØ6x1,2		2									
	Q262030	Arandela muelle A-5		2									
	Q162030	Tuerca exagonal M-5		2									
2	T145007	Generador de vapor		1									
	T145040	Aislante anterior generador		1									
	T145041	Aislante posterior generador		1									
	T145050	Aislante lateral derecho generador		1									
	T115064	Aislante lateral izquierdo generador		1									
	T145042	Aislante superior generador		1									
	T145052	Aislante salida vapor vertical		1									
	Q221343	Remache exagonal M-6		2									
	Q232040	Arandela plana A-6		2									
	Q262040	Arandela muelle A-6		2									
	Q012042	Tornillo exagonal M-6x15		2									
3	T145701	Tapa caja quemador		1									
	T145047	Aislante tapa caja quemador		1									
	Q221342	Remache exagonal M-5		2									
	Q152004	Tornillo aplastado M-5x13		2									
4	T145700	Caja quemador		1									
	T145046	Aislante caja quemador		1									
	Q412002	Remache tubular Ø4x7,5		4									
5	Z955802	Electrodo ignicion		1									
	Q151320	Tornillo alomado M-4x6		1									
6	Z955803	Electrodo deteccion		1									
	Q151320	Tornillo alomado M-4x6		1									

MOD.		HORNOS A GAS HVG			ZONA	GENERADOR DE VAPOR						PLANO	C-1333
ITEM	CODIGO	DENOMINACION	TEXTO	HVG-20/21									NOTAS
7	Z955801	Quemador completo		2									
	Q032021	Tornillo alomado M-4x10		4									
	Q242020	Arandela abanico A-4		4									
	Q162020	Tuerca exagonal M-4		4									
8	Z955807	Arandela junta (corcho)		2									
9	T145714	Acoplador de quemador		1									
	Q151320	Tornillo alomado M-4x6		4									
10	T112609	Soporte quemador		4									
	Q412002	Remache tubular Ø4x7,5		8									
11	T142819	Tapa de quemador		1									
	Q221343	Remache exagonal M-6		2									
	Q232040	Arandela plana A-6		2									
	Q262040	Arandela muelle A-6		2									
	Q012042	Tornillo exagonal M-6x15		2									
12	T115015	Entrada de gas		1									
13	Q221334	Tuerca 1/2" (Para tubo Ø12)		1									
14	U055043	Bicono Ø 12		1									
15	S205023	Manguito doble 1/2"		1									
16	Z952201	Valvula SIT-830 (50 Hz.)		1									(B.P.y Gas Natural, 50 Hz.)
16	Z953501	Valvula SIT-830 (60 Hz.)		1									(B.P.y Gas Natural, 60 Hz.)
17	S205023	Manguito doble 1/2"		1									
18	Q306012	Arandela junta Ø18xØ13x1,5		2									
19	T115109	Conduccion a quemad. generador		1									
20	R723013	Conexión valvula SIT		1									
21	3715600	Tubo silico. forrado Ø26xØ18x450		2									
22	Q881304	Abrazadera 20 - 32		4									
23	R665046	Cuerpo de niveles		1									
	Q232040	Arandela plana A-6		1									
	Q262040	Arandela muelle A-6		1									

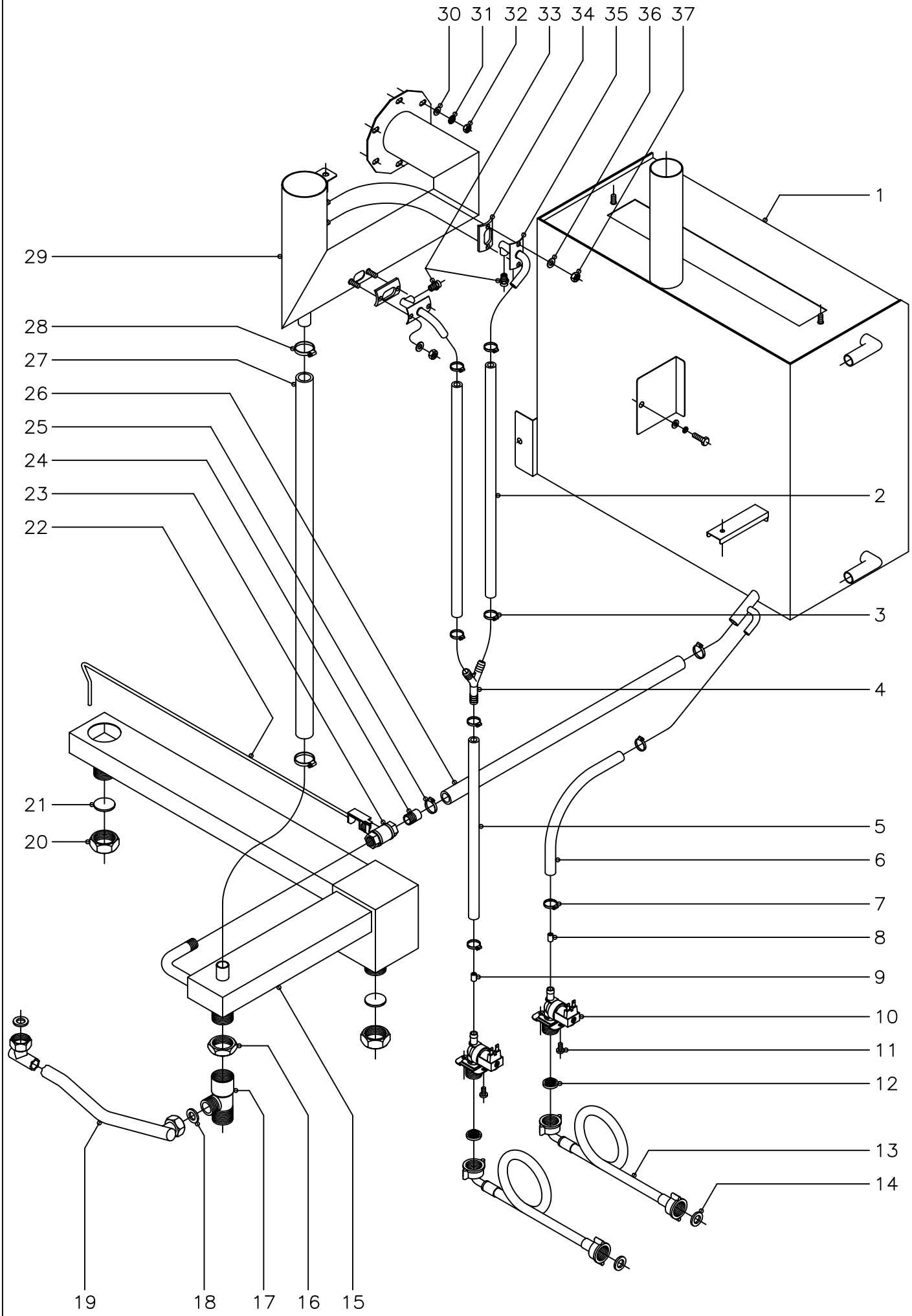

MOD.		HORNOS A GAS HVG		ZONA	CONDUCCIONES AGUA,VAPOR Y DESAGÜE						PLANO	C-1334
ITEM	CODIGO	DENOMINACION	TEXTO	HVG-20/21								NOTAS
1	T145007	Generador de vapor		1								
2	3676900	Tubo goma negra Ø17xØ10x250		2								
3	Q881302	Abrazadera 12 - 20		6								
4	Z201106	Racord en "Y"		1								
5	3676900	Tubo goma negra Ø17xØ10x1000		1								
6	3676900	Tubo goma negra Ø17xØ10x700		1								
7	Q881302	Abrazadera 12 - 20		2								
8	Z601156	Regulador caudal 8 l./m. (rojo)		1								
9	P443042	Regulador caudal 3 l./m. (negro)		1								
10	Z701135	Electrovalvula entrada de agua		2								
11	Q032021	Tornillo alomado M-4x10		4								
12	Z701132	Filtro-junta entrada de agua		2								
13	Z601114	Manguera entrada de agua		2								
14	Q307031	Junta manguera Ø24xØ14x3		2								
15	-	Tubo desagüe completo		1								Soldado a cuerpo de horno
16	Q223014	Contratuerca 1"		1								
17	R145036	Manguito desagüe		1								
18	Q307031	Arandela junta Ø24xØ14x3		2								
19	T145048	Conduccion recogeaguas		1								
20	R665053	Tuerca tapon 1" laton		2								
21	R015011	Arandela junta Ø34x3		2								
22	R032804	Palanca grifo vaciado		1								
23	R015034	Cuerpo grifo vaciado		1								
24	R345014	Manguito grifo vaciado		1								
25	Q881304	Abrazadera 20 - 32		2								
26	3715600	Tubo silico. forrado Ø26xØ18x750		1								
27	3715600	Tubo silico. forrado Ø26xØ18x750		1								
28	Q881304	Abrazadera 20 - 32		2								
29	T145035	Retorno de vapor completo		1								

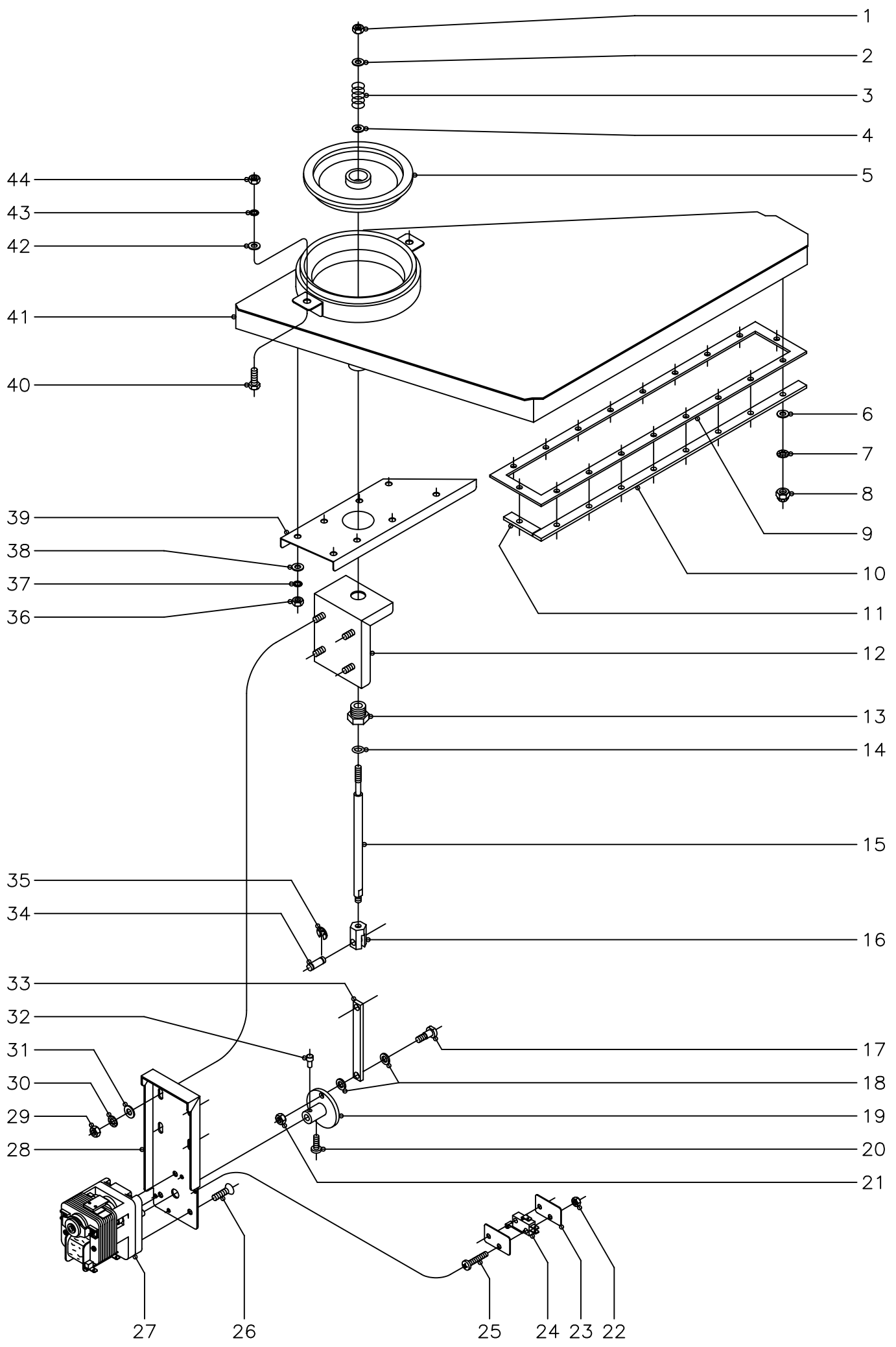

N plano C-1335	Firma 	Fecha 5-2003	Aparato HORNO A GAS HVG-20/21	Lamina 8	Fagor Industrial S.Coop. FAGOR Oñate
-------------------	-----------	-----------------	----------------------------------	-------------	--

MOD.	HORNOS A GAS HVG	ZONA	CIERRE CHIMENEA	PLANO	C-1335
------	------------------	------	-----------------	-------	--------

ITEM	CODIGO	DENOMINACION	TEXTO	HVG-20/21										NOTAS
1	Q162040	Tuerca exagonal M-6		2										
2	Q302022	Arandela plana Ø16xØ6x1,2		1										
3	R725008	Resorte		1										
4	Q302022	Arandela plana Ø16xØ6x1,2		1										
5	T125027	Retencion vapores		1										
6	Q232030	Arandela plana A-5		18										
7	Q242030	Arandela abanico A-5		18										
8	Q212031	Tuerca sombrerete M-5		18										
9	T132631	Junta chimenea		1										
10	T132632	Pletina refuerzo largo inferior		2										
11	T132634	Pletina refuerzo corto inferior		2										
12	T135022	Soporte amarre motor completo		1										
13	R725030	Tuerca guia retencion		1										
14	Q307067	Junta torica Ø14,43xØ9,19xØ2,62		1										
15	T135044	Eje retencion vapores		1										
16	T135045	Suplemento eje retencion		1										
17	T135009	Eje de leva		1										
18	Q308013	Arandela de teflon Ø14xØ8x2		2										
19	T135012	Leva		1										
20	Q012021	Tornillo exagonal M-4x10		1										
21	Q162040	Tuerca exagonal M-6		1										
22	Q221350	Tuerca exagonal autoblocante M-3		4										
23	R010535	Placa separadora		4										
24	R010534	Interruptor		2										
25	Q032013	Tornillo alomado M-3x20		4										
26	Q042031	Tornillo avellanado M-5x10		3										
27	T113010	Motor chimenea		1										
28	T135021	Escuadra amarre motor		1										
29	Q162040	Tuerca exagonal M-6		4										

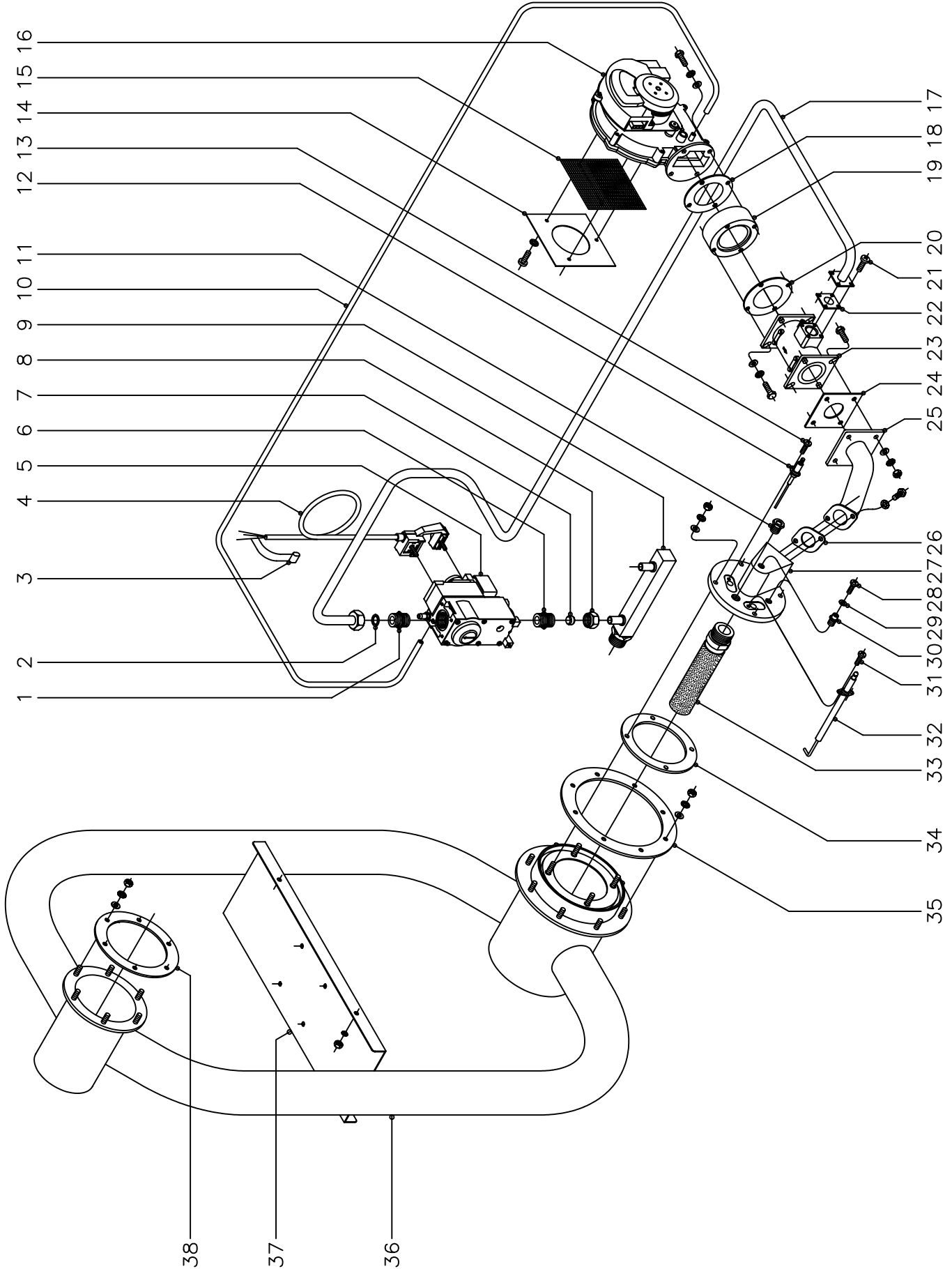

MOD.	HORNOS A GAS HVG	ZONA	PARTE FUNCIONAL GAS	PLANO	C-1336
------	------------------	------	---------------------	-------	--------

ITEM	CODIGO	DENOMINACION	TEXTO	HVG-20/21									NOTAS
1	S205023	Manguito doble 1/2"		1									
2	Q306012	Arandela junta Ø18xØ13x1,5		1									
3	Z233012	Condensador antiparasitario		1									
4	T085012	Conector valvula Honeywell		1									
5	T155018	Valvula Honeywell (Regula. a B.P.)		1									(50 Hz.)
5	T155019	Valvula Honeywell (Regula. a G.N.)		1									(50 Hz.)
5	T155020	Valvula Honeywell (Regula. a B.P.)		1									(60 Hz.)
5	T155021	Valvula Honeywell (Regula. a G.N.)		1									(60 Hz.)
6	S205023	Manguito doble 1/2"		1									
7	U055043	Bicono Ø 12		1									
8	Q221334	Tuerca 1/2" (Para tubo Ø12)		1									
9	T115015	Entrada de gas		1									
10	3702400	Tubo goma negra Ø 8xØ 4x1500		1									
11	R725015	Visor de encendido		1									
12	T135705	Electrodo de deteccion		1									
13	Q153021	Tornillo alomado M-4x10		1									
14	T115096	Chapa amarre malla ventilador		1									
	Q032021	Tornillo alomado M-4x10		3									
	Q242020	Arandela abanico A-4		3									
15	T115095	Malla ventilador		1									
16	T143000	Ventilador E.B.M.-RG-148		1									
17	T145054	Conduccion de gas completa		1									
18	T115081	Junta acoplamiento ventilador y mixer		1									
19	T115076	Acoplamiento ventilador mixer		1									
20	T115081	Junta acoplamiento Ventilador y mixer		1									
21	Q032021	Tornillo alomado M-4x10		4									
22	T115080	Junta conduccion mixer		1									
23	T115075	Mixer 35 KW.		1									
24	T115079	Junta mixer conducto		1									

MOD.		HORNOS A GAS HVG			ZONA	PARTE FUNCIONAL GAS						PLANO	C-1336
ITEM	CODIGO	DENOMINACION	TEXTO	HVG-20/21									NOTAS
25	T115077	Conducto mixer tapa principal		1									
26	T095021	Junta conducto tapa		1									
27	T115782	Tapa principal		1									
	Q232030	Arandela plana A-5		4									
	Q242030	Arandela abanico A-5		4									
	Q163030	Tuerca exagonal M-5 laton		4									
28	Q152024	Tornillo avellanado M-4x8		2									
29	R725061	Junta toma de presion		2									
30	R725017	Boquilla toma de presion		2									
31	Q153021	Tornillo alomado M-4x10		1									
32	T135706	Electrodo de ignicion		1									
33	T145712	Quemador Furigas (20/11 y 20/21)		1									
34	R725055	Junta de tapa principal		1									
35	T145710	Junta camara combustion		1									
36	T155700	Intercambiador completo		1									
	Q232040	Arandela plana A-6		14									
	Q262040	Arandela muelle A-6		14									
	Q163140	Tuerca exagonal M-6 laton		14									
37	T092615	Separador central		1									
	Q262040	Arandela muelle A-6		2									
	Q162040	Tuerca exagonal M-6		2									
38	T145711	Junta de colector		2									

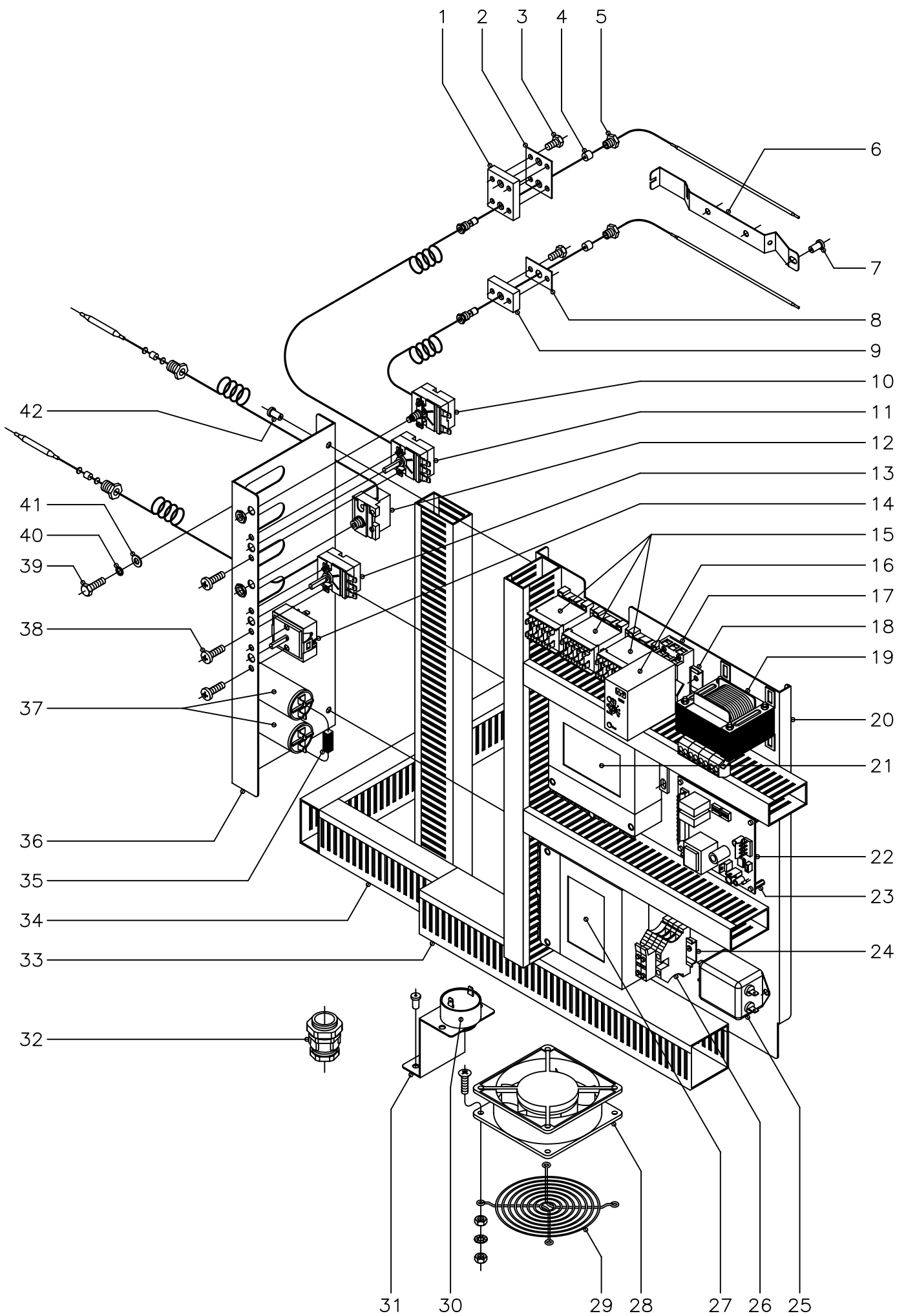

N plano C-1337	Firma <i>[Signature]</i>	Fecha 5-2003	Aparato CUADRO ELECTRICO HORNO A GAS HVG-20/21	Lamina 10	Fagor Industrial S.Coop. FAGOR Onate
-------------------	-----------------------------	-----------------	--	--------------	--

MOD.		HORNOS A GAS HVG		ZONA	CUADRO ELECTRICO							PLANO	C-1337
ITEM	CODIGO	DENOMINACION	TEXTO	HVG-20/21								NOTAS	
1	R662659	Pasamuros doble		1									
2	R692811	Junta pasamuros doble		1									
3	Q012021	Tornillo exagonal M-4x10		6									
4	R662662	Junta cierre bulbo limitador		2									
5	R662629	Racord cierre sonda		2									
6	R662630	Soporte bulbo		2									
7	Q412002	Remache tubular Ø4x7,5		6									
8	R692812	Junta pasamuros simple		1									
9	T112625	Pasamuros simple		1									
10	R243016	Limitador temperatura horno		1									
11	R343018	Termostato horno		1									
12	Z953036	Termostato limitador generador		1									
13	R343100	Termostato generador (30 - 85°C.)		1									
14	S333001	Regulador de energia		1									
15	Z683087	Contactador 3TF20 01-3AL2 230V.		3									
16	R343072	Detector de niveles		1									
17	R743009	Base enchufable detector		1									
18	Z123019	Guia contactor L=175		1									
19	R503005	Transformador		1									
20	T133005	Panel cuadro electrico		1									
21	Z953004	Control combustion		1									
22	T083002	Variador de velocidad		1									
23	T133007	Distanciador M-3		4								Amarre variador a cuadro	
	T133008	Tornillo amarre M-3x23 (plastico)		4								Amarre variador a cuadro	
	Q161310	Tuerca exagonal M-3		4								Amarre variador a cuadro	
24	Z123018	Guia contactor L=55		1									
25	T113023	Filtro de entrada modelo FF-6Z		1									
26	P453026	Borne tierra 10		1									
	R073005	Borna portafusibles		2									

MOD.		HORNOS A GAS HVG			ZONA	CUADRO ELECTRICO						PLANO	C-1337
ITEM	CODIGO	DENOMINACION	TEXTO	HVG-20/21									NOTAS
	R723015	Fusible cristal 10 A.		2									
	Z263303	Tope final		1									
27	Z953004	Control combustion		1									
28	Z103066	Ventilador 230 V., 50-60 Hz.		3									
29	T113015	Proteccion ventilador		3									
	Q042022	Tornillo avellanado M-4x15		12									
	Q242020	Arandela abanico A-4		12									
	Q162020	Tuerca exagonal M-4		24									
30	R693067	Zumbador		1									
31	T143001	Soporte zumbador		1									
	Q412002	Remache tubular Ø 4x7,5		2									
32	R073004	Prensaestopas		1									
33	3715510	Canaleta unex (60x60x longitud)		1									
34	3715520	Canaleta unex (60x30x longitud)		7									
35	R073008	Cableado PTC		1									
36	T133006	Apoyo componentes		1									
37	T093005	Condensador		2									
38	Q151320	Tornillo alomado M-4x6		6									
39	Q012042	Tornillo exagonal M-6x15		4									
40	Q262040	Arandela muelle A-6		4									
41	Q232040	Arandela plana A-6		4									
42	Q412002	Remache tubular Ø 4x7,5		3									

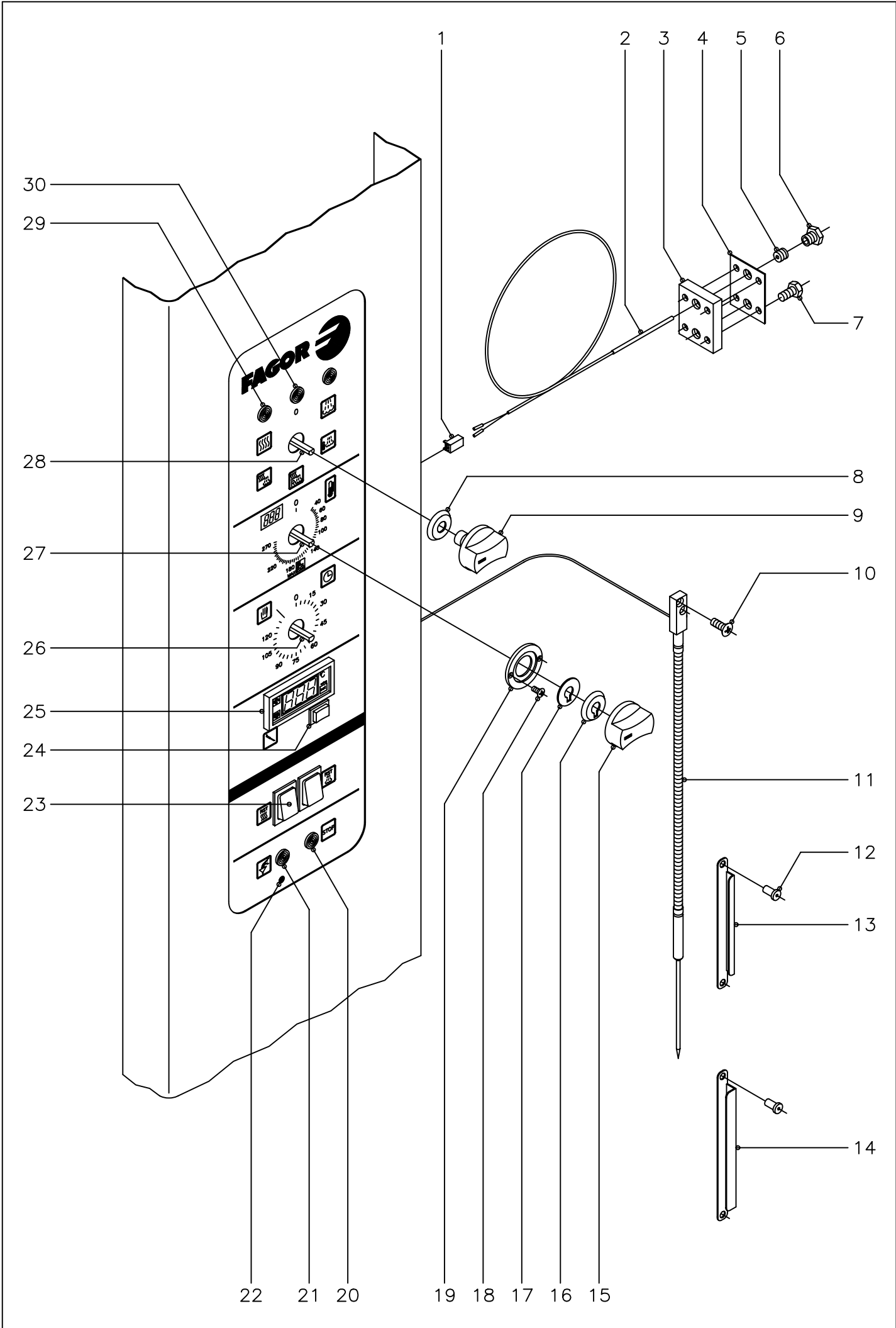

N plano
C-1338

Firma
[Signature]

Fecha
5-2003

Aparato PARTE ELECTRICA PORTAMANDOS
HORNO A GAS HVG-20/21

Lamina
11

Fagor Industrial S.Coop. **FAGOR**
Onate

MOD.	HORNOS A GAS HVG	ZONA	PARTE ELECTRICA PORTAMANDOS	PLANO	C-1338
------	------------------	------	-----------------------------	-------	--------

ITEM	CODIGO	DENOMINACION	TEXTO	HVG-20/21										NOTAS
1	R663092	Conector 2 vias		1										
2	R663090	Conjunto termopar L=1400		1										
3	R662659	Pasamuros doble		1										
4	R692811	Junta pasamuros doble		1										
5	R662652	Bicono cierre sonda		1										
6	R662629	Racord cierre sonda		1										
7	Q012021	Tornillo exagonal M-4x10		4										
8	R663046	Junta (conmutadores)		2										
9	R663062	Boton de mando Ø6 (conmutadores)		2										
10	Q042022	Tornillo avellanado M-4x15		2										
11	T133000	Conjunto sonda nucleo		1										
12	Q412002	Remache tubular Ø 4x7,5		4										
13	R092633	Retenedor de sonda		2										
14	R672643	Soporte de sonda		1										
15	R663063	Boton de mando Ø6 (termos.electro.)		1										
16	R663045	Junta (termostato electronico)		1										
17	R662810	Arandela guia		1										
18	Q151346	Tornillo avellanado M-3x5		2										
19	R662809	Guia boton de mando		1										
20	T113040	Piloto rojo		1										
21	R693056	Piloto ambar		1										
22	Z953035	Termostato limitador aviso		1										
23	Z213033	Pulsador rearme generador y horno		2										
24	R743008	Interruptor regulacion sonda		1										
25	T133004	Termostato digital tipo K		1										
26	R723000	Temporizador manual		1										
27	R743013	Termostato electronico 0 - 270° C.		1										
	R663036	Fijacion circuito termost. electroni.		4										
28	T113030	Conmutador de funciones		1										

MOD.		HORNOS A GAS HVG			ZONA	PIEZAS ESPECIFICAS PARA LOS DISTINTOS GASES (B.P. Y G.N.) Y DISTINTAS FRECUENCIAS (50 Y 60 Hz.)						PLANO	C-1333 C-1336
ITEM	CODIGO	DENOMINACION	TEXTO	HVG-20/21									NOTAS
		<u>BUTANO - PROPANO 50 Hz.</u>											
s/n	Z955899	Inyector Ø 0,7 (En quemador item 7)		12									Plano C-1333
16	Z952201	Valvula SIT-830 50 Hz. (B.P.y G.N.)		1									Plano C-1333
5	T155018	Valvula Honeywell 50Hz. (B.P.)		1									Plano C-1336
		<u>BUTANO - PROPANO 60 Hz.</u>											
s/n	Z955899	Inyector Ø 0,7 (En quemador item 7)		12									Plano C-1333
16	Z953501	Valvula SIT-830 60 Hz. (B.P.y G.N.)		1									Plano C-1333
5	T155020	Valvula Honeywell 60Hz. (B.P.)		1									Plano C-1336
		<u>GAS NATURAL 50 Hz.</u>											
s/n	Z956104	Inyector Ø 1,1 (En quemador item 7)		12									Plano C-1333
16	Z952201	Valvula SIT-830 50 Hz. (B.P.y G.N.)		1									Plano C-1333
5	T155019	Valvula Honeywell 50Hz. (G.N.)		1									Plano C-1336
		<u>GAS NATURAL 60 Hz.</u>											
s/n	Z956104	Inyector Ø 1,1 (En quemador item 7)		12									Plano C-1333
16	Z953501	Valvula SIT-830 60 Hz. (B.P.y G.N.)		1									Plano C-1333
5	T155021	Valvula Honeywell 60Hz. (G.N.)		1									Plano C-1336

HVG-10/11 HVG-10/21 HVG-20/11 HVG-20/21
 MFHVG-10/11 MFHVG-10/21 MFHVG-20/11 MFHVG-20/21

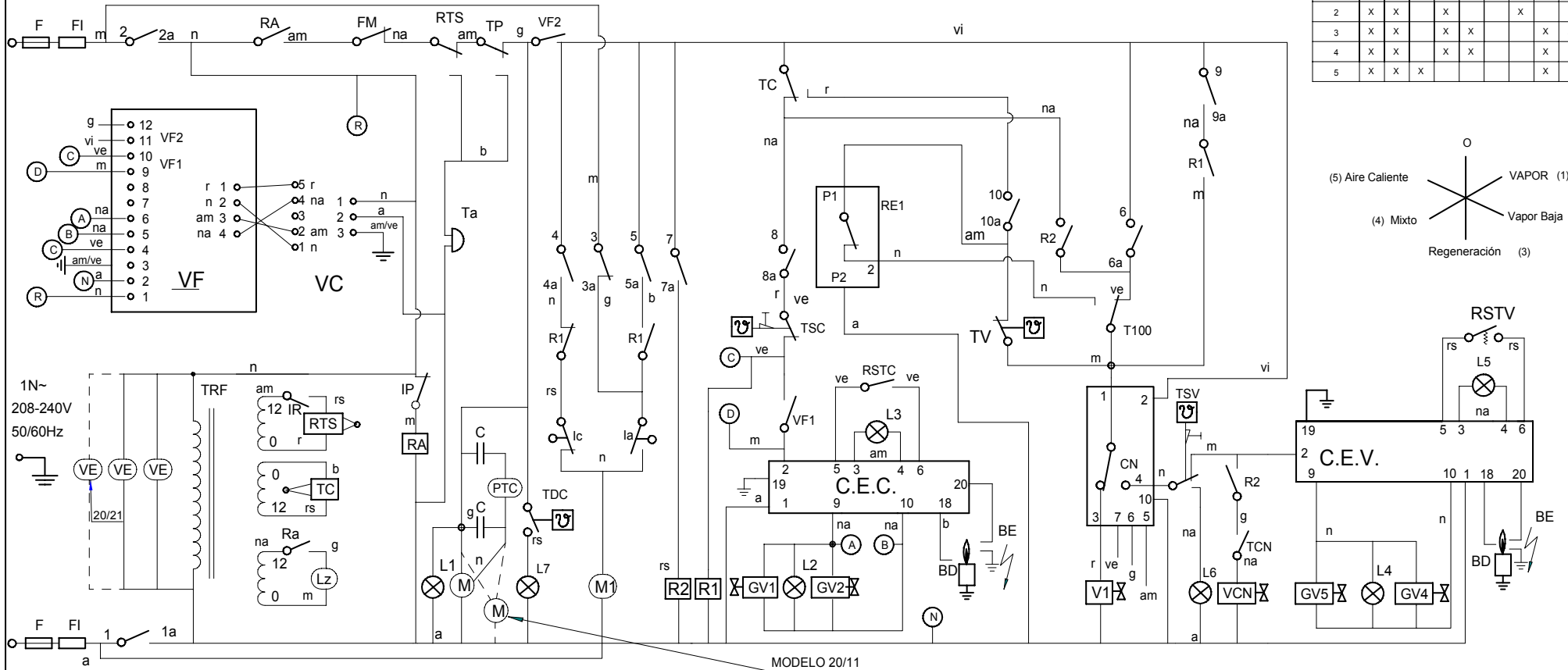

MODELO 20/11

T-113031

Esquema teorico adhesivo		T-113031	
Nº	Cant.	Material	Nº Clasificación
Nº	Modificación	Propuesta de	Fecha
1	Introducir VE	Maillo	16/10/2001
		Tolerancias generales	
		<5±	50-100± :
		5-25± :	> 100±
		25-50± :	∞±
Dibujado		Firma	Fecha
Proyectado		KONTXI	22/2/01
Comprobado		FAGOR 	
Escala		Fagor Industrial, Koop. Elk. Mugatua	
5		HORNO HVG	
Plano hau ez daiteke erabili ez berrizta gure baimenitz gabe		Mecanizado superficial	
		Plano numero	
		HC-75606 -01	
		Sustituye al Nº HC-75448	
		Sustituido por	

ESPAÑOL

FRANÇAIS

ENGLISH

DEUTSCH

ITALIANO

CODIGO DE COLORES:

r = rojo
a = azul
m = marron
g = gris
n = negro
b = blanco
vi = violeta
am = amarillo
na = naranja
rs = rosa
ve = verde
am/ve = amarillo verde

COMPONENTES:

BD = Bujía de detector de llama
BE = Bujía de Encendido
C = Condensador Motor
C.E.C. = Control Encendido cámara
C.E.V. = Control encendido vapor
CN = Control nivel de agua
① F, F1, F2, F3 = Fusible
FI = Filtro interferencias
FM = Térmico Motor
GV1 = Electroválvula de gas cámara (Control)
GV2 = Electroválvula de gas cámara (Seguridad)
GV4 = Electroválvula de gas vapor (Control)
GV5 = Electroválvula de gas vapor (Seguridad)
la = Micro chimenea abierta
lc = Micro chimenea cerrada
IG = Interruptor general
IP = Interruptor puerta
IR = Selector regulador sonda núcleo
L1 = Lámpara de funcionamiento
L2 = Lámpara calentamiento cámara
L4 = Lámpara entrada de vapor
L3 = Lámpara indicador de bloqueo cámara
L5 = Lámpara indicador de bloqueo vapor
L6 = Lámpara seguridad de vapor
L7 = Lámpara detección de cal
Lz = Luz interior cámara
M = Motor
M1 = Motor accionamiento chimenea
R2, R1, Ra = Relé Auxiliar
RE1 = Regulador de energía
RSTC = Pulsador de rearme cámara
RSTV = Pulsador de rearme vapor
RTS = Regulador sonda núcleo
T100 = Termostato fijo 100°C
Ta = Timbre avisador
TC = Termostato cámara
TCN = Termostato condensación
TDC = Termostato detección de cal
① TP, TMP = Temporizador
① TRF, TRF1 = Transformador
TSC = Termostato seguridad cámara
TSV = Termostato seguridad de vapor
TV = Termostato de vapor
V1 = Electroválvula de agua de llenado
VC = Ventilador centrifugo premezcla
VCN = Electroválvula de agua de condensación
VE = Ventilador cuadro eléctrico
VF = Variador de frecuencia

CODES DE COULEURS:

r = rouge
a = bleu
m = marron
g = gris
n = noir
b = blanc
vi = violet
am = jaune
na = orange
rs = rose
ve = vert
am/ve = jaune/vert

COMPOSANTS:

BD = Veilleuse de détection de flamme
BE = Veilleuse d'allumage
C = Condensateur moteur
C.E.C. = Controle d'allumage de chambre
C.E.V. = Controle d'allumage de vapeur
CN = Controle du niveau d'eau
① F, F1, F2, F3 = Fusible
FI = Filtre interférences
FM = Moteur thermique
GV1 = Electrovalve de chambre gaz (control)
GV2 = Electrovalve de chambre gaz (sécurité)
GV4 = Electrovalve de vapeur gaz (control)
GV5 = Electrovalve de vapeur gaz (sécurité)
la = Micro cheminée ouverte
lc = Micro cheminée fermée
IG = Interruptor general
IP = Interruptor de porte
IR = Sélecteur régulateur de sonde noyau
L1 = Lampe de fonctionnement
L2 = Lampe de chauffe chambre
L4 = Lampe d'arrivée de vapeur
L3 = Lampe témoin de blocage de chambre
L5 = Lampe témoin de blocage de vapeur
L6 = Lampe de sureté de vapeur
L7 = Lampe de détection de calcaire
Lz = LumiÈre intérieure de chambre
M = Moteur
M1 = Actionnement moteur de cheminée
R2, R1, Ra = Relais auxiliaire
RE1 = Régulateur d'énergie
RSTC = Bouton de réarmement de chambre
RSTV = Bouton de réarmement de vapeur
RTS = Régulateur de sonde noyau
T100 = Thermostat fixe 100°C
Ta = Sonnerie d'alarme
TC = Thermostat de chambre
TCN = Thermostat de condensation
TDC = Thermostat de détection de calcaire
① TP, TMP = Temporisateur 0-120
① TRF, TRF1 = Transformador
TSC = Thermostat de sureté de chambre
TSV = Thermostat de sureté de vapeur
TV = Thermostat de vapeur
V1 = Electrovalve de remplissage d'eau
VC = Ventilateur de centrifugeuse de prémélange
VCN = Electrovalve de condensation d'eau
VE = Ventilateur tableau électrique
VF = Variador de frecuencia

COLOUR CODE

r = red
a = blue
m = brown
g = grey
n = black
b = white
vi = violet
am = yellow
na = orange
rs = pink
ve = green
am/ve = yellow-green

COMPONENTS:

BD = Flame detector spark plug
BE = Ignition spark plug
C = Motor condenser
C.E.C. = Cooking chamber ignition control
C.E.V. = Steam ignition control
CN = Water level control
① F, F1, F2, F3 = Fusible
FI = Interference filter
FM = Motor thermal switch
Cooking chamber gas solenoid valve (control)
GV2 = Cooking chamber gas solenoid valve (safety)
GV4 = Steam gas solenoid valve (control)
GV5 = Steam gas solenoid valve (safety)
la = Chimney open microswitch
lc = Chimney closed microswitch
IG = Interruptor general
IP = Door switch
IR = Core probe regulator selector
L1 = On/off lamp
L2 = Cooking chamber heating lamp
L4 = Steam inlet lamp
L3 = Cooking chamber lock indicator lamp
L5 = Steam lock indicator lamp
L6 = Steam safety lamp
L7 = Lime detection lamp
Lz = Cooking chamber interior lamp
M = Motor
M1 = Chimney drive motor
R2, R1, Ra = Auxiliary relay
RE1 = Energy regulator
RSTC = Cooking chamber reset button
RSTV = Steam reset button
RTS = Core probe regulator
T100 = Fixed 100°C thermostat
Ta = Warning buzzer
TC = Cooking chamber thermostat
TCN = Condensation thermostat
TDC = Lime detection thermostat
① TP, TMP = 0-120 timer
① TRF, TRF1 = Transformer
TSC = Cooking chamber safety thermostat
TSV = Steam safety thermostat
TV = Steam thermostat
V1 = Water filling solenoid valve
VC = Pre-mix centrifuge fan
VCN = Condensation water solenoid valve
VE = Switchboard fan
VF = Frequency inverter

FARBENCODE

r = rot
a = blau
m = braun
g = grau
n = schwarz
b = weiss
vi = violett
am = gelb
na = orangers
rs = rosa
ve = grün
am/ve = gelb/grün

KOMPONENTEN:

BD = Zündkerze des Flammendetektors
BE = Zündkerze der Zündung
C = Motorkondensator
C.E.C. = Zündkontrolle Kammer
C.E.V. = Zündkontrolle Dampf
CN = Kontrolle Wasserstand
① F, F1, F2, F3 = Fusible
FI = Interferenzfilter
FM = Thermometer
GV1 = Electroventil Gas, Kammer (Kontrolle)
GV2 = Electroventil Gas, Kammer (Sicherheit)
GV4 = Electroventil Gas, Dampf (Kontrolle)
GV5 = Electroventil Gas, Dampf (Sicherheit)
la = Mikroschacht geöffnet
lc = Mikroschacht geschlossen
IG = Hauptschalter
IP = Turschalter
IR = Wahlregler Kernsonde
L1 = Funktionsleuchtanzeige
L2 = Erwärmungsleuchtanzeige Kammer
L4 = Leuchtanzeige Dampftritt
L3 = Leuchtanzeige Blockierung Kammer
L5 = Leuchtanzeige Blockierung Dampf
L6 = Sicherheitsleuchtanzeige Dampf
L7 = Kalkanzeige
Lz = Innenbeleuchtung Kammer
M = Motor
M1 = Motorantrieb Mikroschacht
R2, R1, Ra = Relé Auxiliar
RE1 = Hilfsrelais
RSTC = Bedienungstaste Durch, Aufladung Kammer
RSTV = Bedienungstaste Durch, Aufladung Dampf
RTS = Kernsondenregler
T100 = Thermostat auf 100°C
Ta = Meldeklögel/Lautwerk
TC = Thermostat Kammer
TCN = Kondensationsthermostat
TDC = Thermostat Kalkanzeige
① TP, TMP = Zeitschalter 0-120
① TRF, TRF1 = Transformator
TSC = Sicherheitsthermostat Kammer
TSV = Sicherheitsthermostat Dampf
TV = Dampfthermostat
V1 = Elektroventil Wasserfüllung
VC = Zentrifugallüfter Vormischung
VCN = Elektroventil Kondenswasser
VE = Schaltaffventilator
VF = Frequenzwandler

CODICE DEI COLORI:

r = rosso
a = azzurro
m = marrone
g = grigio
n = nero
b = bianco
vi = viola
am = giallo
na = arancione
rs = rosa
ve = verde
am/ve = giallo/verde

COMPONENTI:

BD = Candela del rilevatore di fiamma
BE = Candela d'accensione
C = Condensatore motore
C.E.C. = Controllo accensione cabina
C.E.V. = Controllo accensione vapore
CN = Controllo livello d'acqua
① F, F1, F2, F3 = Fusibile
FI = Filtro interferenze
FM = Termico Motore
GV1 = Elettrovalvola gas cabina (controllo)
GV2 = Elettrovalvola gas cabina (sicurezza)
GV4 = Elettrovalvola gas vapore (controllo)
GV5 = Elettrovalvola gas vapore (sicurezza)
la = Micro camino aperto
lc = Micro camino chiuso
IG = Interruttore generale
IP = Interruttore porta
IR = Selettore regolatore sonda nucleo
L1 = Lampadina di funzionamento
L2 = Lampadina riscaldamento cabina
L4 = Lampadina ingresso vapore
L3 = Lampadina indicatore di blocco cabina
L5 = Lampadina indicatore di blocco vapore
L6 = Lampadina di sicurezza vapore
L7 = Lampadina rilevatore di calcare
Lz = Luce interna cabina
M = Motore
M1 = Motore funzionamento camino
R2, R1, Ra = Relais ausiliario
RE1 = Regolatore d'energia
RSTC = Pulsante di riarmo vapore
RSTV = Regolatore sonda nucleo
RTS = Regolador Sonda Nucleo
T100 = Termostato fisso 100°C
Ta = Campanello avvisatore
TC = Termostato cabina
TCN = Termostato condensazione
TDC = Termostato rilevatore di calcare
① TP, TMP = Timer 0-120
① TRF, TRF1 = Transformador
TSC = Termostato sicurezza cabina
TSV = Termostato sicurezza vaspore
TV = Termostato vapore
V1 = Elettrovalvola acqua di riempimento
VC = Ventilatore centrifuga
VCN = Elettrovalvola acqua di condensazione
VE = Ventilatore quadro elettrico
VF = Variatore di frequenza

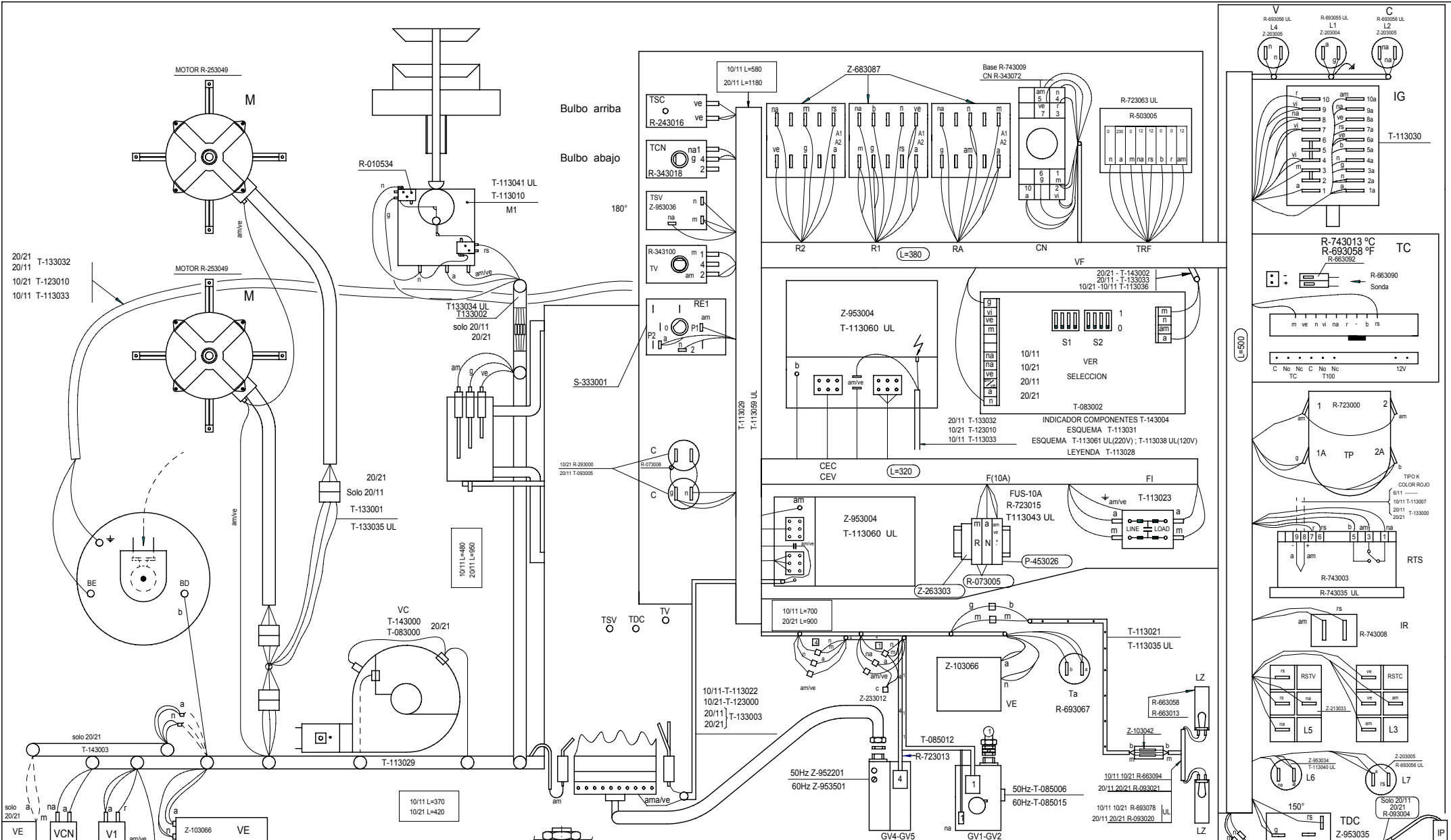

20/21 T-133032
20/11 T-123010
10/11 T-113033

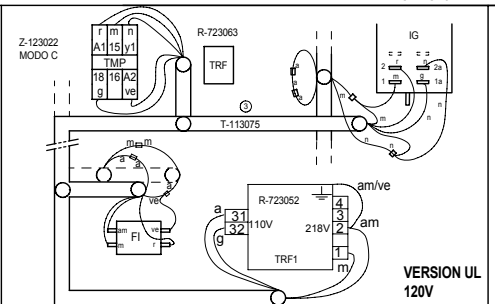
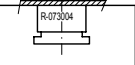
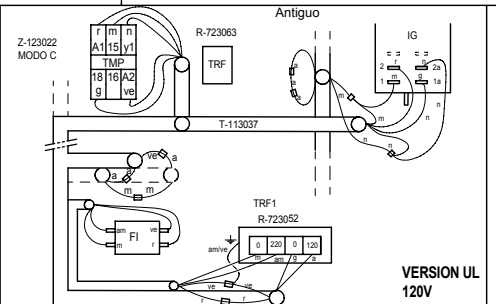

Esquema de montaje HVG			T113032000		
Nº	Pieza	Cant.	Material	Nº Clasificación	Acabado
01	Introducir UL		Maillo	22/10/2001	
02	Introducir T113060 y T113059 en UL		Maillo	22/11/2002	<5±
02	eliminar T113042 en UL		Maillo		5-25±
03	Eliminar T-113037 e introducir T-113075 (UL)		M.Maillo	24-01-2003	> 100±
					25-50±
					<X±
Dibujado			Firma		FAGOR Fagor Industrial, Koop Elk. Mugatua
Proyectado			Fecha		
Comprobado					
Escala					
HORNOS HVG					Plano numero HD -12786 - 03
Sostituye al Nº					Sostituido por

Plano hau ez dabilen erabil ez berria gure balentzi gabe