

---

# DESPIECES DEL SERVICIO TECNICO

---

**Hornos Mixtos con Caldera  
Fours Mixtes avec Chaudière  
Combi Ovens with Steam Generator  
Gas-Heißluftdämpfer  
Forni Misti con Boiler a Gas**

**HVG-10/11**

**HVG-10/21**

**HVG-2.10/11**

**Octubre 2001 October**



**Fagor Industrial**

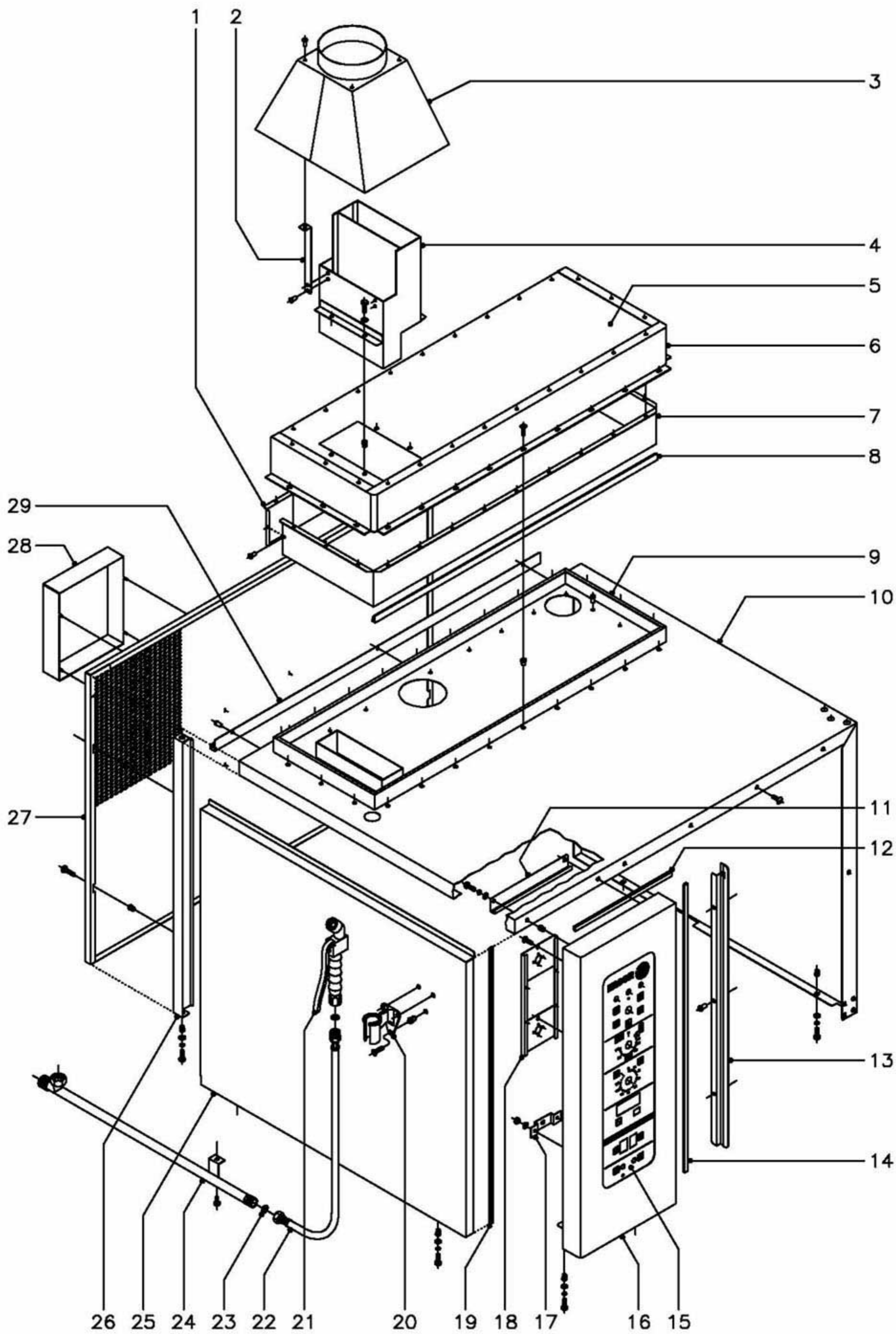

N plano	Firma	Fecha	Aparato	MUEBLE	Lamina	Fagor Industrial S.Coop. <b>FAGOR</b>
C-1085		10-2001	HORNOS A GAS HVG-10/11 Y 10/21		1	Oñate

MOD.		HORNOS A GAS HVG		ZONA		MUEBLE						PLANO		C-1085
ITEM	CODIGO	DENOMINACION	TEXTO	HVG-10/11	HVG-10/21								NOTAS	
1	T-112809	Posterior de camara colector		1	-									
1	T122810	Posterior de camara colector		-	1									
	Q412002	Remache tubular Ø4x7,5		11	12									
2	T112815	Soporte chimenea		4	4									
	Q412002	Remache tubular Ø4x7,5		12	12									
3	T122820	Chimenea exterior completa		1	1									
4	T122816	Salida de colector copleta		1	1									
	Q221342	Remache exagonal M-5		4	4									
	Q232030	Arandela plana A-5		4	4									
	Q012031	Tornillo exagonal M-5x10		4	4									
5	T112805	Posterior de colector		1	-									
5	T122808	Posterior de colector		-	1									
6	T112806	Anterior de colector		1	-									
6	T122807	Anterior de colector		-	1									
	Q221342	Remache exagonal M-5		24	26									
	Q152004	Tornillo aplastado M-5x13		24	26									
7	T112808	Anterior de camara colector		1	-									
7	T122809	Anterior de camara colector		-	1									
	Q412002	Remache tubular Ø4x7,5		15	16									
8	3715200	Junta de estanqueidad L=2500		1	-									
8	3715200	Junta de estanqueidad L=2800		-	1									
9	T112822	Bandeja de colector completa		1	-									
9	T122814	Bandeja de colector completa		-	1									
	Q412002	Remache tubular Ø4x7,5		20	22									
10	T112836	Cuerpo exterior de horno		1	-									
10	T122821	Cuerpo exterior de horno		-	1									
	Q221343	Remache exagonal M-6		17	17									
	Q232040	Arandela plana A-6		25	25									
	Q262040	Arandela muelle A-6		25	25									

MOD.

HORNOS A GAS HVG

ZONA

MUEBLE

PLANO

C-1085

ITEM	CODIGO	DENOMINACION	TEXTO	HVG-10/11	HVG-10/21								NOTAS
	Q012042	Tornillo exagonal M-6x15		25	25								
	Q152017	Tornillo amarre M-6x13		5	5								
11	T112821	Canaleta portamandos		1	1								
12	3715400	Junta panel portamandos L=300		1	1								
13	R672624	Protector de portamandos		1	1								
	Q412002	Remache tubular Ø4x7,5		3	3								
14	3715400	Junta panel portamandos L=770		1	1								
15	T113014	Serigrafia portamandos HVG		1	1								
16	T112810	Panel portamandos		1	1								
	Q221343	Remache exagonal M-6		4	4								
	Q232040	Arandela plana A-6		4	4								
	Q262040	Arandela muelle A-6		4	4								
	Q012042	Tornillo exagonal M-6x15		4	4								
17	Z952911	Soporte limitador aviso		1	1								
	Q242030	Arandela abanico A-5		2	2								
	Q162030	Tuerca exagonal M-5		2	2								
18	T112812	Soporte componentes		1	1								
	Q152004	Tornillo aplastado M-5x13		2	2								
19	3715400	Junta panel portamandos L=770		1	1								En panel lateral
20	R095007	Soporte de ducha		1	1								
	Q221342	Remache exagonal M-4		3	3								
	Q042022	Tornillo avellanado M-4x15		3	3								
21	R095005	Cuerpo de ducha		1	1								
22	R095006	Flexible de ducha		1	1								
23	-	Arandela junta (con cuerpo ducha)		2	2								
24	R675002	Suplemento ducha		1	-								
24	R685003	Suplemento ducha		-	1								
	Q012042	Tornillo exagonal M-6x15		1	1								

MOD.													HORNOS A GAS HVG			ZONA	MUEBLE								PLANO		C-1085
ITEM	CODIGO	DENOMINACION	TEXTO	HVG-10/11	HVG-10/21																NOTAS						
25	T112817	Panel lateral anterior		1	-																						
25	T122805	Panel lateral anterior		-	1																						
	Q221343	Remache exagonal M-6		2	2																						
	Q232040	Arandela plana A-6		2	2																						
	Q262040	Arandela muelle A-6		2	2																						
	Q012042	Tornillo exagonal M-6x15		2	2																						
26	T112818	Panel lateral posterior		1	1																						
	Q221343	Remache exagonal M-6		2	2																						
	Q232040	Arandela plana A-6		2	2																						
	Q262040	Arandela muelle A-6		2	2																						
	Q012042	Tornillo exagonal M-6x15		2	2																						
27	T112803	Panel posterior exterior		1	-																						
27	T122802	Panel posterior exterior		-	1																						
	Q221342	Remache exagonal M-5		4	4																						
	Q152038	Tornillo amarre M-5x30		4	4																						
28	T082808	Tapa de separacion		1	1																						
29	T112819	Protector superior		1	-																						
29	T122813	Protector superior		-	1																						
	Q412002	Remache tubular Ø4x7,5		3	3																						

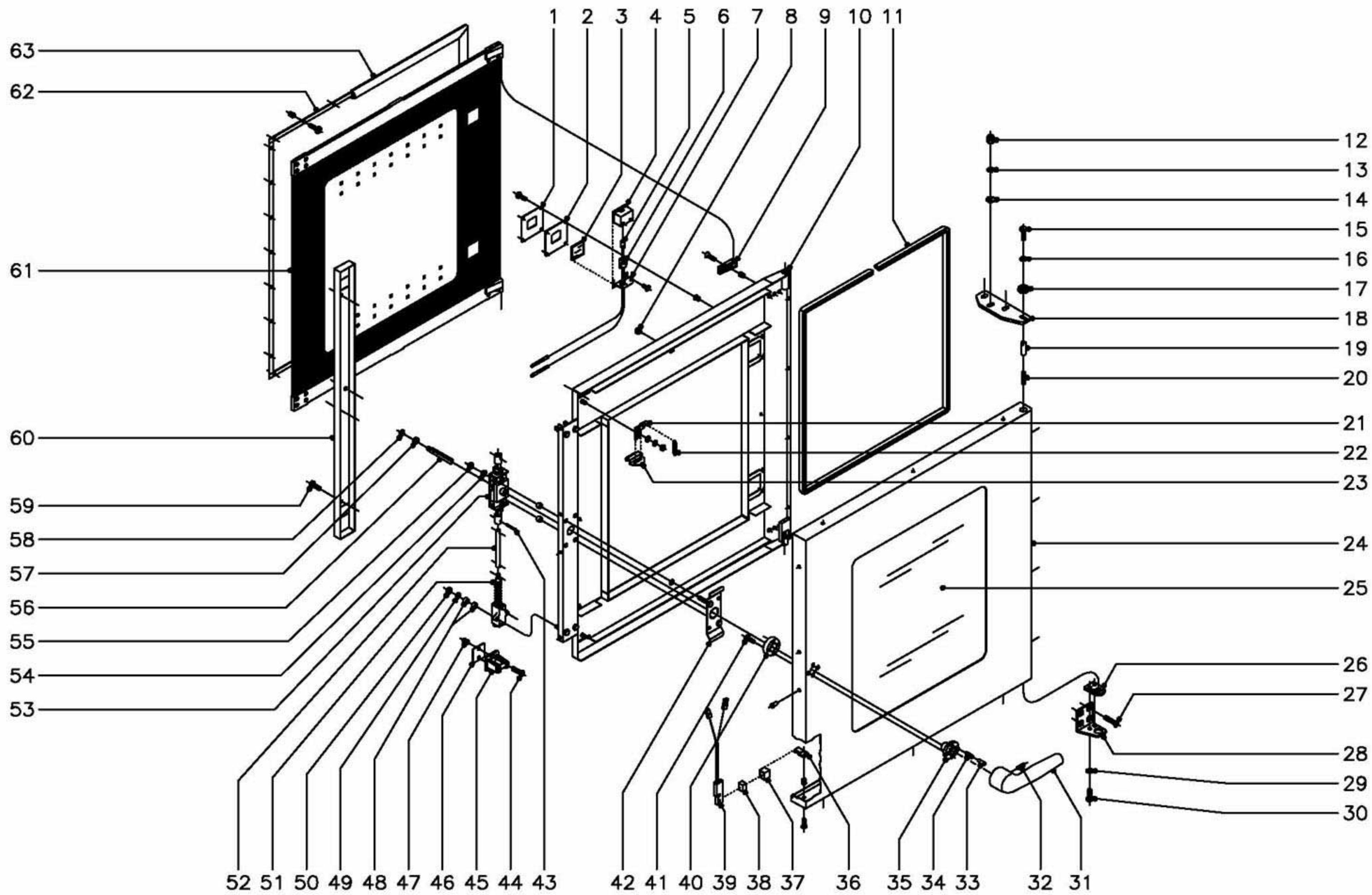

N plano C-1086	Firma 	Fecha 10-2001	Aparato PUERTA HORNOS A GAS HVG-10/11 Y 10/21	Lamina 2	Fagor Industrial S.Coop. <b>FAGOR</b> Orate
-------------------	-----------	------------------	---	-------------	--

MOD.		HORNOS A GAS HVG		ZONA	PUERTA						PLANO	C-1086
ITEM	CODIGO	DENOMINACION	TEXTO	HVG-10/11	HVG-10/21							NOTAS
	1100002595	KIT Puerta completa 10/11		1	-							
	1100002596	KIT Puerta completa 10/21		-	1							
1	R670608	Tapa cierre lampara		2	2							
	Q032021	Tornillo alomado M-4x10		8	8							
	Q222041	Remache exagonal M-4		8	8							
2	R670609	Junta cierre lampara		2	2							
3	R670618	Cristal de lampara		2	2							
4	R670610	Deflector de lampara		2	2							
5	R663013	Lampara 10 W. 12 V.		2	2							
6	R663058	Portalamparas		2	2							
7	R670611	Suplemento deflector		2	2							
	Q042031	Tornillo avellanado M-5x10		4	4							
8	R670617	Tope cristal interior		6	6							
9	R670615	Base de bisagra		2	2							
	Q042032	Tornillo avellanado M-5x15		2	2							
	Q222011	Remache exagonal M-5		2	2							
10	R670601	Contrapuerta completa 10/11		1	-							
10	R680601	Contrapuerta completa 10/21		-	1							
11	3715200	Junta cristal L=2000		1	-							
11	3715200	Junta cristal L=2300		-	1							
12	Q212051	Tuerca sombrerete M-8		3	3							
13	Q242050	Arandela abanico A-8		3	3							
14	Q302025	Arandela plana Ø8,4xØ20x1,5		3	3							
15	Q012042	Tornillo exagonal M-6x15		1	1							
16	Q242040	Arandela abanico A-6		1	1							
17	R662807	Arandela amarre puerta		1	1							
18	T130500	Bisagra superior		1	1							
19	R660534	Eje superior		1	1							

MOD.		HORNOS A GAS HVG		ZONA	PUERTA						PLANO	C-1086
ITEM	CODIGO	DENOMINACION	TEXTO	HVG-10/11	HVG-10/21							NOTAS
20	Z850519	Resorte		1	1							
21	R670612	Base de pestillo		2	2							
	Q302022	Arandela plana Ø16xØ6x1,2		2	2							
	Q242040	Arandela abanico A-6		2	2							
	Q162040	Tuerca exagonal M-6		2	2							
22	R660605	Muelle tensor pestillo		2	2							
23	R670613	Pestillo sujecion cristal interior		2	2							
24	R670600	Panel puerta 10/11		1	-							
24	R680600	Panel puerta 10/21		-	1							
	Q412002	Remache tubular Ø4x7,5		14	14							
25	R670625	Cristal exterior 10/11		1	-							
25	R680609	Cristal exterior 10/21		-	1							
26	R660549	Guia eje inferior		1	1							
27	Q062040	Tornillo avellanado M-6x16		4	4							
28	R660551	Bisagra inferior		1	1							
29	Q242040	Arandela abanico A-6		2	2							
30	Q012041	Tornillo exagonal M-6x10		2	2							
31	T130502	Manilla		1	1							
32	Q132042	Varilla roscada M-6x15		1	1							
33	T130507	Piton enganche		2	2							
34	T130506	Resorte		2	2							
35	T130503	Guia manilla		1	1							
36	T130513	Soporte iman		1	1							
37	Z200507	Protector iman		1	1							
38	Z200506	Iman		1	1							
39	Z100522	Interruptor magnetico		1	1							
40	T130504	Soporte resortes		1	1							
41	Q032032	Tornillo alomado M-5x15		2	2							
42	T130511	Suplemento fijacion cerradura		1	1							



MOD.

HORNOS A GAS HVG

ZONA

PUERTA

PLANO

C-1086

ITEM	CODIGO	DENOMINACION	TEXTO	HVG-10/11	HVG-10/21									NOTAS
43	Q352001	Pasador de aletas Ø2x15		4	4									
44	Q042032	Tornillo avellanado M-5x15		4	4									
45	R260545	Enganche		2	2									
46	R660538	Calzo de enganche		4	4									
47	Q221342	Remache exagonal M-5		4	4									
48	Z608410	Casquillo		10	10									
49	Q242040	Arandela abanico A-6		4	4									
50	Q162040	Tuerca exagonal M-6		4	4									
51	R260544	Elemento de cierre		2	2									
52	R020502	Tubo alargadera		2	2									
53	T130509	Mecanismo de cierre		1	1									
54	Q242040	Arandela abanico A-6		2	2									
55	Q162040	Tuerca exagonal M-6		2	2									
56	T130508	Eje de manilla		1	1									
57	T130505	Casquillo		1	1									
58	Q271033	Arandela de seguridad Ø6		1	1									
59	Q032021	Tornillo alomado M-4x10		4	4									
60	R670620	Tapa cierre puerta		1	1									
61	1100002807	KIT Cristal interior completo 10/11		1	-									
61	1100002808	KIT Cristal interior completo 10/21		-	1									
62	R670513	Fijacion junta completa 10/11		1	-									
62	R680511	Fijacion junta completa 10/21		-	1									
	Q033021	Tornillo alomado M-4x10 ( laton )		28	28									
	Q222041	Remache exagonal M-4 inox.		28	28									
63	R670500	Junta de puerta 10/11		1	-									
63	R680500	Junta de puerta 10/21		-	1									

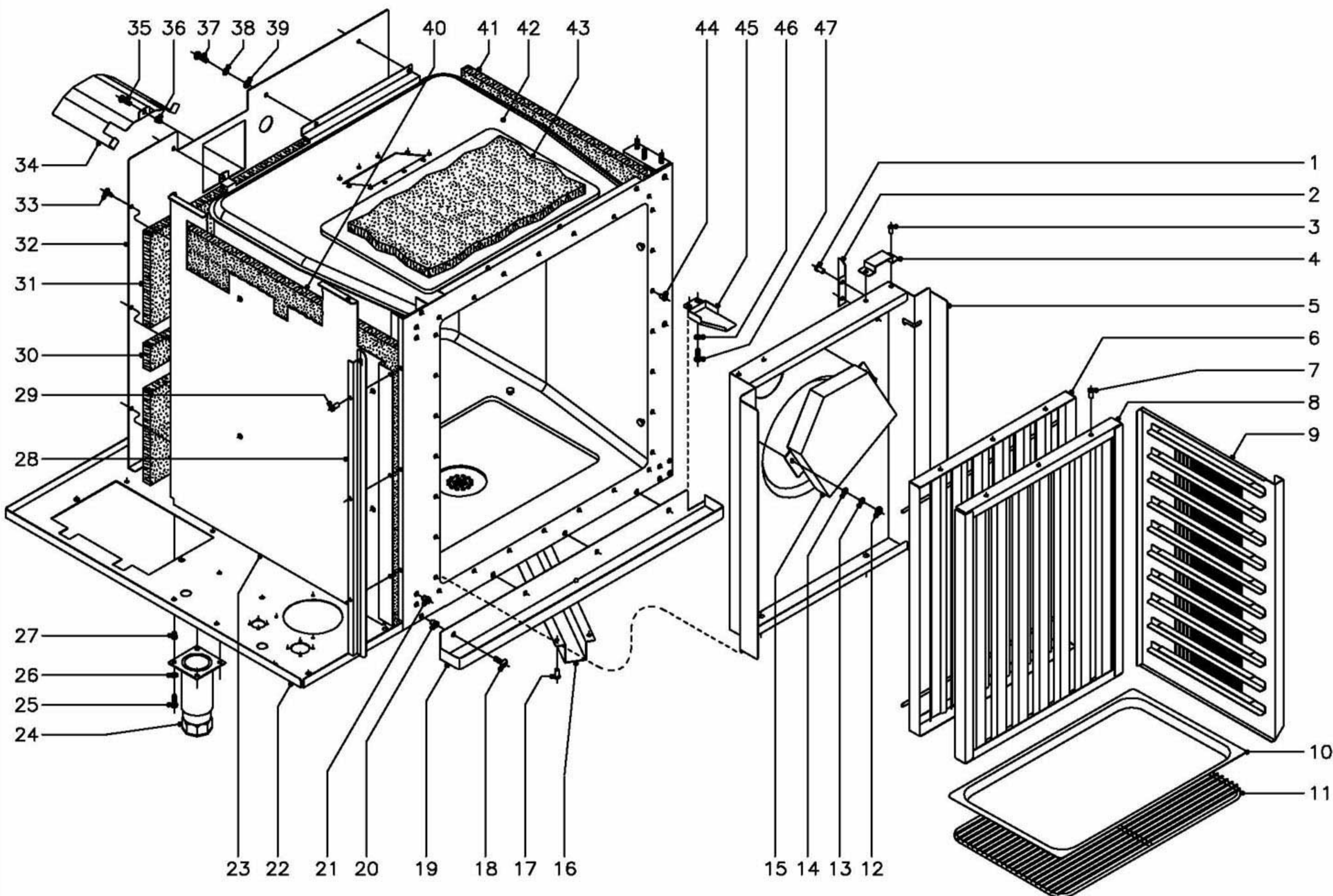

N plano	Firma	Fecha	Aparato	MUEBLE INTERIOR	Lamina	Fagor Industrial S.Coop. <b>FAGOR</b>
C-1087		10-2001	HORNOS A GAS HVG-10/11 Y 10/21		3	Ofoto

MOD.

HORNOS A GAS HVG

ZONA

MUEBLE INTERIOR

PLANO

C-1087

ITEM	CODIGO	DENOMINACION	TEXTO	HVG-10/11	HVG-10/21														NOTAS
1	Q412002	Remache tubular Ø4x7,5		4	4														
2	R292647	Escuadra sujecion cubreventilador		2	2														
3	Q412002	Remache tubular Ø4x7,5		4	4														
4	T122613	Apoyo cubreventilador		2	2														
5	T112620	Cubreventilador 10/11		1	-														
5	T122611	Cubreventilador 10/21		-	1														
6	R092621	Posterior de filtro		1	1														
7	Q412002	Remache tubular Ø4x7,5		6	6														
8	R092618	Anterior de filtro		1	1														
9	T112615	Guia de bandejas derecha 10/11		1	-														
9	T122614	Guia de bandejas derecha 10/21		-	1														
s/n	T112617	Guia de bandejas izquierda 10/11		1	-														
s/n	T122616	Guia de bandejas izquierda 10/21		-	1														
10	R252816	Bandeja 1/1 ( 530x325x20 )		1	-														
10	R032605	Bandeja 2/1 ( 530x650x40 )		-	1														
11	R672665	Parrilla 1/1		1	-														
11	R682676	Parrilla 2/1		-	1														
12	Q162030	Tuerca exagonal M-5		2	2														
13	Q242030	Arandela abanico A-5		2	2														
14	Q232030	Arandela plana A-5		2	2														
15	T112610	Conduccion de humos		1	1														
16	R672804	Cubredesagüe		1	-														
16	R682805	Cubredesagüe		-	1														
17	Q412002	Remache tubular Ø4x7,5		8	8														
18	Q152017	Tornillo amarre M-6x13		4	4														
19	T112813	Recogeaguas		1	-														
19	T122811	Recogeaguas		-	1														
20	Q221343	Remache exagonal M-6		4	4														
21	Q221342	Remache exagonal M-5		4	4														

MOD.

HORNOS A GAS HVG

ZONA

MUEBLE INTERIOR

PLANO

C-1087

ITEM	CODIGO	DENOMINACION	TEXTO	HVG-10/11	HVG-10/21								NOTAS
22	T112800	Base exterior de horno		1	-								
22	T122800	Base exterior de horno		-	1								
23	T112624	Soporte lateral aislante		1	-								
23	T122619	Soporte lateral aislante		-	1								
24	X260151	Pata regulable		4	4								
25	Q012031	Tornillo exagonal M-5x10		16	16								
26	Q242030	Arandela abanico A-5		16	16								
27	Q221342	Remache exagonal M-5		16	16								
28	R672624	Protector portamandos		1	1								
29	Q412002	Remache tubular Ø4x7,5		3	3								
30	R662616	Aislante posterior 560x60x20		4	4								
31	R672631	Aislante posterior 670x230x20		2	-								
31	R032625	Aislante posterior 760x230x20		-	2								
32	T112607	Soporte aislante posterior		1	-								
32	T122604	Soporte aislante posterior		-	1								
33	Q151301	Tornillo alomado		3	3								
34	R142614	Tejadillo motor		2	2								
35	Q012042	Tornillo exagonal M-6x15		2	2								
36	Q221343	Remache exagonal M-6		2	2								
37	Q012042	Tornillo exagonal M-6x15		12	12								
38	Q262040	Arandela muelle A-6		12	12								
39	Q232040	Arandela plana A-6		12	12								
40	R672630	Aislante lateral 770x650x20		3	-								
40	R682623	Aislante lateral 860x790x20		-	3								
41	R672630	Aislante lateral 770x650x20		2	-								
41	R682623	Aislante lateral 860x790x20		-	2								
42	T112622	Cuerpo interior horno		1	-								
42	T122620	Cuerpo interior horno		-	1								
43	R662614	Aislante base y techo 650x650x20		6	-								

MOD.

HORNOS A GAS HVG

ZONA



MUEBLE INTERIOR

PLANO

C-1087

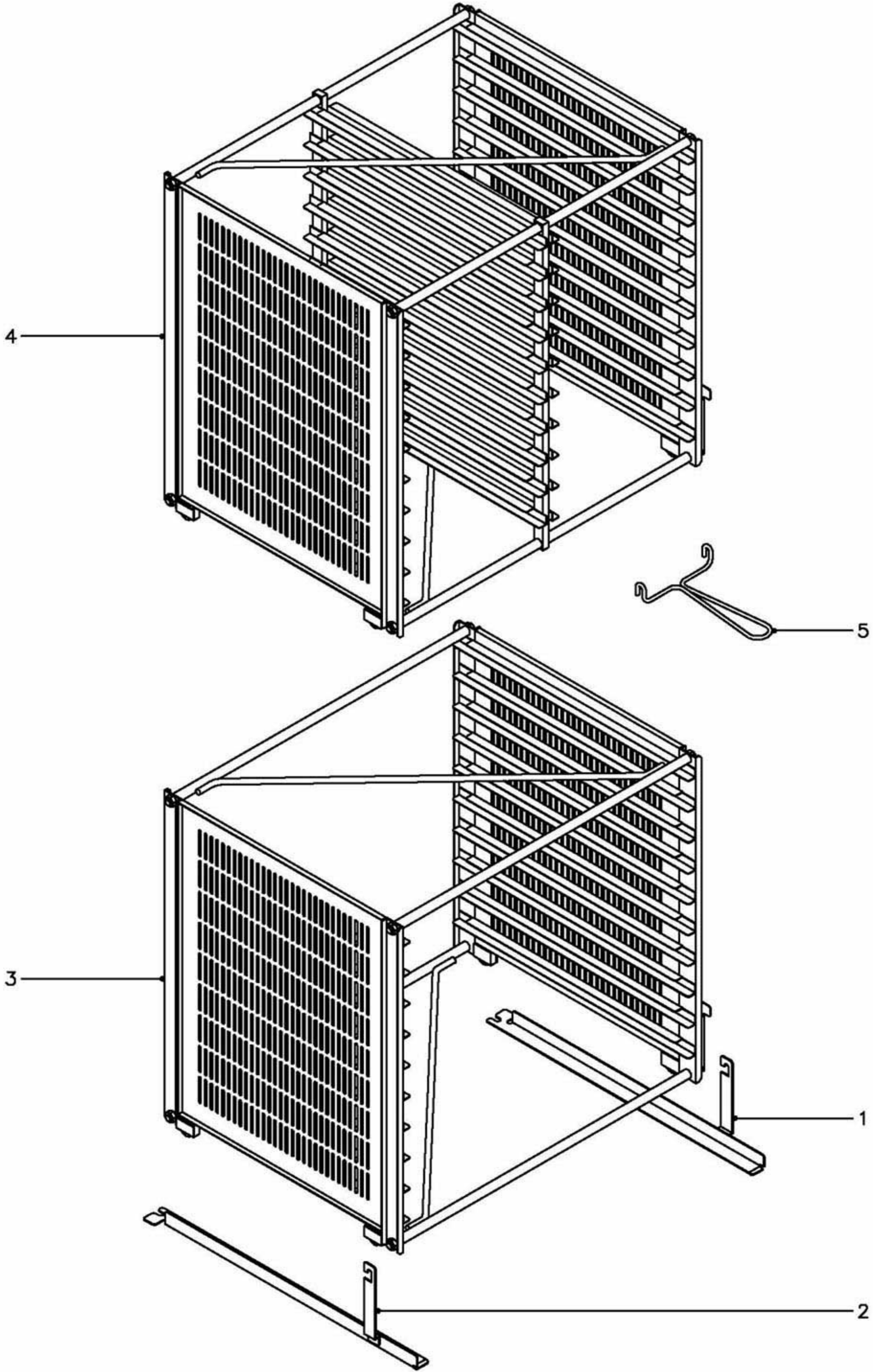
ITEM	CODIGO	DENOMINACION	TEXTOS	HVG-10/11	HVG-10/21													NOTAS
43	R682623	Aislante base y techo 860x790x20		-	6													
44	Q221341	Remache exagonal M-4		28	28													
45	R662800	Cubrecables		1	1													
46	Q232030	Arandela plana A-5		2	2													
47	Q012031	Tornillo exagonal M-5x10		2	2													



N plano C-1088	Firma 	Fecha 10-2001	Aparato EXTRUCTURAS PORTABANDEJAS HORNOS A GAS HVG-10/11,10/21,2-10/11	Lamina 4	Fagor Industrial S.Coop. <b>FAGOR</b>  Ofate
-------------------	--	------------------	--	-------------	--

<b>ITEM</b>	<b>CODIGO</b>	<b>DENOMINACION</b>	<b>TEXTO</b>	<b>HVG-10/11</b>	<b>HVG-10/21</b>	<b>HVG-2-10/11</b>									<b>NOTAS</b>
1100002631		KIT EXSTRUCTURA PORTABANDE. 10/11			OP.	-	-								OP.= Opcional
1	R672623	Rail derecho		OP.	-	-									Optionnel
2	R672622	Rail izquierdo		OP.	-	-									In option
3	R672617	Extractura 10/11		OP.	-	-									
5	R672632	Tirador de estructura		OP.	-	-									
1100002634		KIT EXSTRUCTURA PORTABANDE. 10/21			-	OP.	-								
1100002635		KIT EXSTRUCTURA PORTABANDE. 2-10/11			-	-	1								
1	R682659	Rail derecho		-	OP.	1									
2	R682658	Rail izquierdo		-	OP.	1									
3	R682617	Extractura 10/21		-	OP.	-									
4	R682618	Extractura 2-10/11		-	-	1									
5	R672632	Tirador de estructura		-	OP.	1									

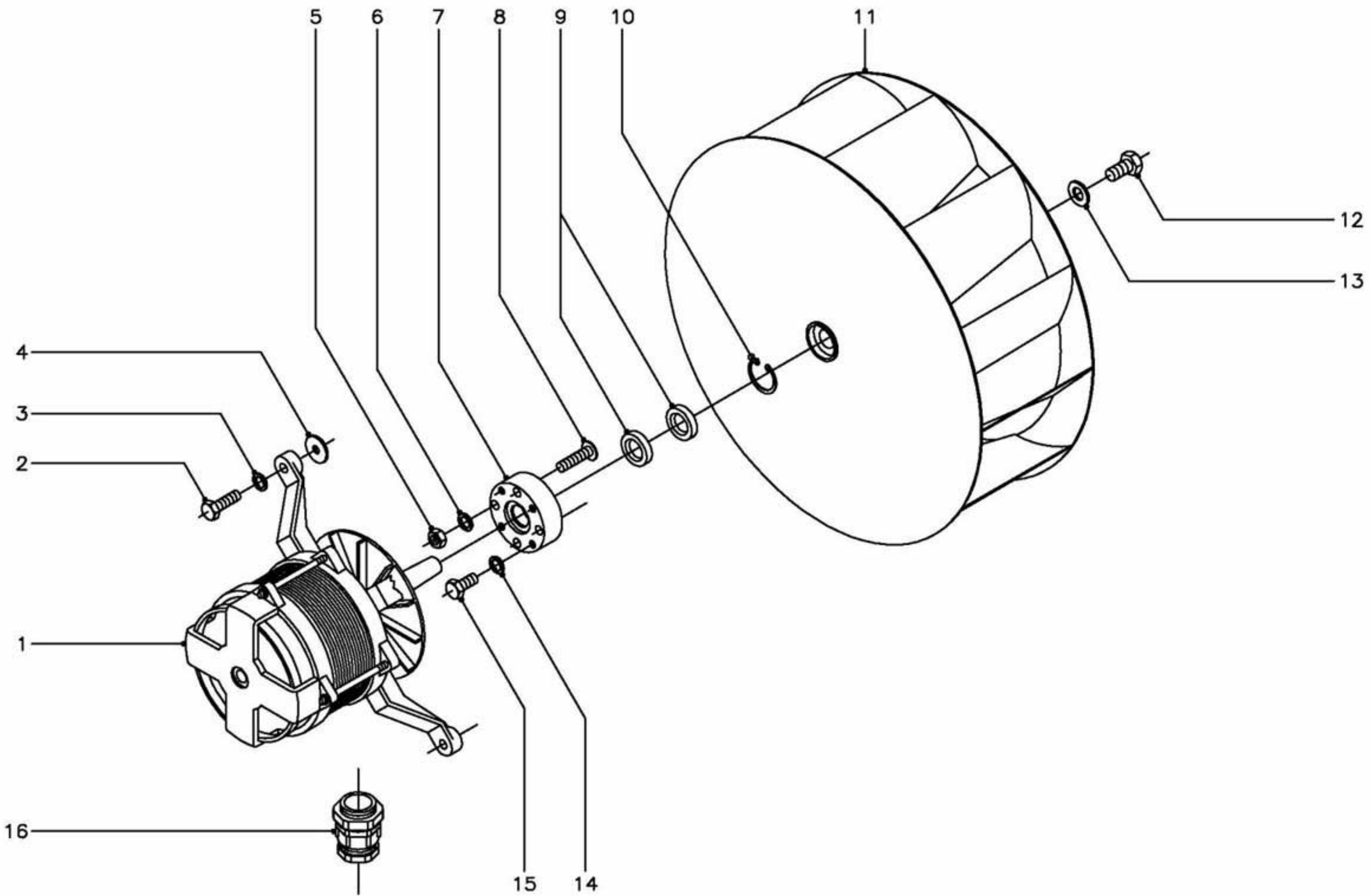

N plano	Firma	Fecha	Aparato	Lamina	Fagor Industrial S.Coop. <b>FAGOR</b>
C-1089		10-2001	TURBINA HORNOS A GAS HVG-10/11 Y 10/21	5	Ofote



MOD.

HORNOS A GAS HVG

ZONA

TURBINA

PLANO

C-1089

ITEM	CODIGO	DENOMINACION	TEXTO	HVG-10/11	HVG-10/21											NOTAS
1	R253049	Motor ( 230/400 V., 50/60 Hz.)		1	1											
2	Q012044	Tornillo exagonal M-6x25		4	4											
3	Q262040	Arandela muelle A-6		4	4											
4	Q301304	Arandela calzo Ø 23xØ 6,5x2		8	8											
5	Q162040	Tuerca exagonal M-6		4	4											
6	Q262040	Arandela muelle A-6		4	4											
7	R662623	Casquillo reten		1	1											
8	-	Perno M-6 ( Caldeado a cuerpo )		4	4											
9	R662627	Reten Ø 28xØ 17x7		2	2											
10	Q302023	Anillo de seguridad Ø 28x1,2		1	1											
11	R253042	Turbina		1	1											
12	Q012063	Tornillo exagonal M-10x20		1	1											
13	Q232060	Arandela plana A-10		1	1											
14	Q232030	Arandela muelle A-5		4	4											
15	Q012031	Tornillo exagonal M-5x10		4	4											
16	R073004	Prensaestopas		1	1											

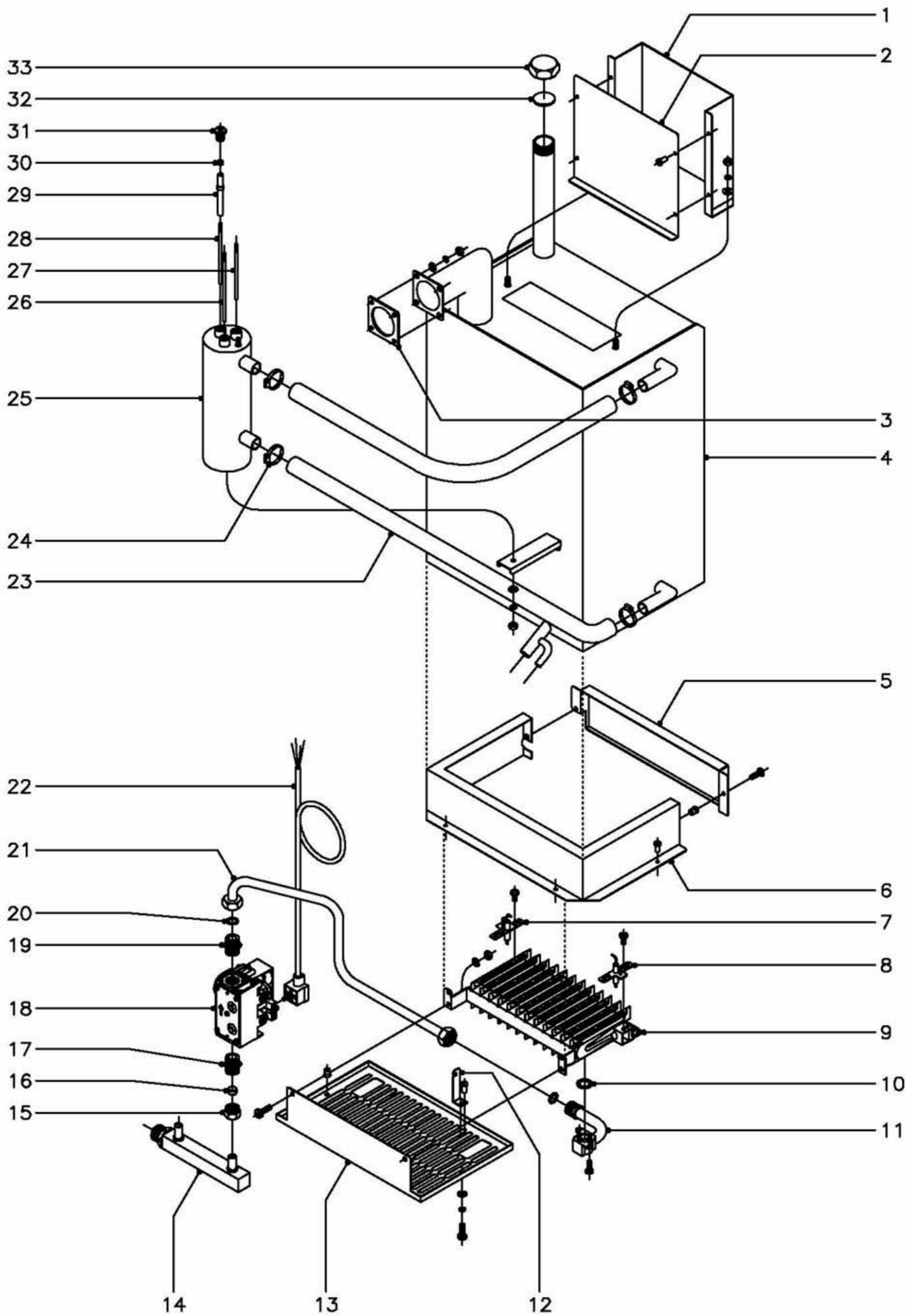

N plano  
C-1090

Firma

Fecha  
10-2001

Aparato  
GENERADOR DE VAPOR  
HORNOS A GAS HVG-10/11 Y 10/21

Lamina  
6

Fagor Industrial S.Coop. **FAGOR**  
Oñate

MOD.

HORNOS A GAS HVG

ZONA

GENERADOR DE VAPOR

PLANO

C-1090

ITEM	CODIGO	DENOMINACION	TEXTO	HVG-10/11	HVG-10/21									NOTAS
1	T115009	Anterior de chimenea generador		1	1									
	T115041	Aislante anterior de chimenea		1	1									
	Q302022	Arandela plana Ø16xØ6x1,2		2	2									
	Q262030	Arandela muelle A-5		2	2									
	Q162030	Tuerca exagonal M-5		2	2									
2	T115010	Posterior de chimenea generador		1	1									
	T115066	Aislante posterior de chimenea		1	1									
	Q412002	Remache tubular Ø4x7,5		4	4									
3	T115037	Junta entrada vapor		1	1									
4	T115000	Generador de vapor		1	1									
	T115039	Aislante anterior generador		1	1									
	T115040	Aislante posterior generador		1	1									
	T115064	Aislante lateral generador		2	2									
	T115065	Aislante superior generador		1	1									
	Q232040	Arandela plana A-6		4	4									
	Q262040	Arandela muelle A-6		4	4									
	Q162040	Tuerca exagonal M-6		4	4									
5	T115701	Tapa caja quemador		1	1									
	T115068	Aislante tapa caja quemador		1	1									
	Q221342	Remache exagonal M-5		2	2									
	Q152004	Tornillo aplastado M-5x13		2	2									
6	T115700	Caja quemador		1	1									
	T115067	Aislante caja quemador		1	1									
	Q412002	Remache tubular Ø4x7,5		4	4									
7	Z955802	Electrodo ignicion		1	1									
	Q151320	Tornillo alomado M-4x6		1	1									
8	Z955803	Electrodo deteccion		1	1									
	Q151320	Tornillo alomado M-4x6		1	1									

MOD.

HORNOS A GAS HVG

ZONA

GENERADOR DE VAPOR

PLANO

C-1090

ITEM	CODIGO	DENOMINACION	TEXTO	HVG-10/11	HVG-10/21								NOTAS
9	Z955801	Quemador completo		1	1								
	Q032021	Tornillo alomado M-4x10		2	2								
	Q242020	Arandela abanico A-4		2	2								
	Q162020	Tuerca exagonal M-4		2	2								
10	Z955807	Arandela junta (corcho)		1	1								
11	T115703	Acoplador de quemador		1	1								
	Q151320	Tornillo alomado M-4x6		2	2								
12	T112609	Soporte quemador		2	2								
	Q412002	Remache tubular Ø4x7,5		4	4								
13	T112829	Tapa de quemador		1	1								
	Q221343	Remache exagonal M-6		2	2								
	Q232040	Arandela plana A-6		2	2								
	Q262040	Arandela muelle A-6		2	2								
	Q012042	Tornillo exagonal M-6x15		2	2								
14	T115015	Entrada de gas		1	1								
15	Q221336	Tuerca M-18x1,5 ( Para tubo Ø12 )		1	1								
16	U055043	Bicono Ø 12		1	1								
17	S205023	Manguito doble 1/2"		1	1								
18	Z952201	Valvula SIT-830 ( 50 Hz.)		1	1								( G.L.P.y Gas Natural, 50 Hz.)
18	Z953501	Valvula SIT-830 ( 60 Hz.)		1	1								( G.L.P.y Gas Natural, 60 Hz.)
19	S205023	Manguito doble 1/2"		1	1								
20	Q306012	Arandela junta Ø18xØ13x1,5		2	2								
21	T115011	Conduccion a quemador generador		1	1								
22	R723013	Conexión valvula SIT		1	1								
23	3713000	Tubo silicona forrado Ø28xØ20x450		2	2								
24	Q881304	Abrazadera 20 - 32		4	4								
25	R665046	Cuerpo de niveles		1	1								
	Q232040	Arandela plana A-6		1	1								
	Q262040	Arandela muelle A-6		1	1								

ITEM	CODIGO	DENOMINACION	TEXTO	HVG-10/11	HVG-10/21												NOTAS
	Q162040	Tuerca exagonal M-6		1	1												
26	R345060	Electrodo de nivel alto L=106		1	1												
27	R345063	Electrodo de nivel bajo L=116		1	1												
28	R345064	Electrodo de masa L=131		1	1												
29	R345059	Guia aislante de electrodos		3	3												
30	Q163020	Tuerca exagonal M-4		6	6												
31	R345058	Racord amarre electrodos		3	3												
32	R015011	Arandela junta Ø34x3		1	1												
33	R015010	Tuerca tapon 1" inox.		1	1												

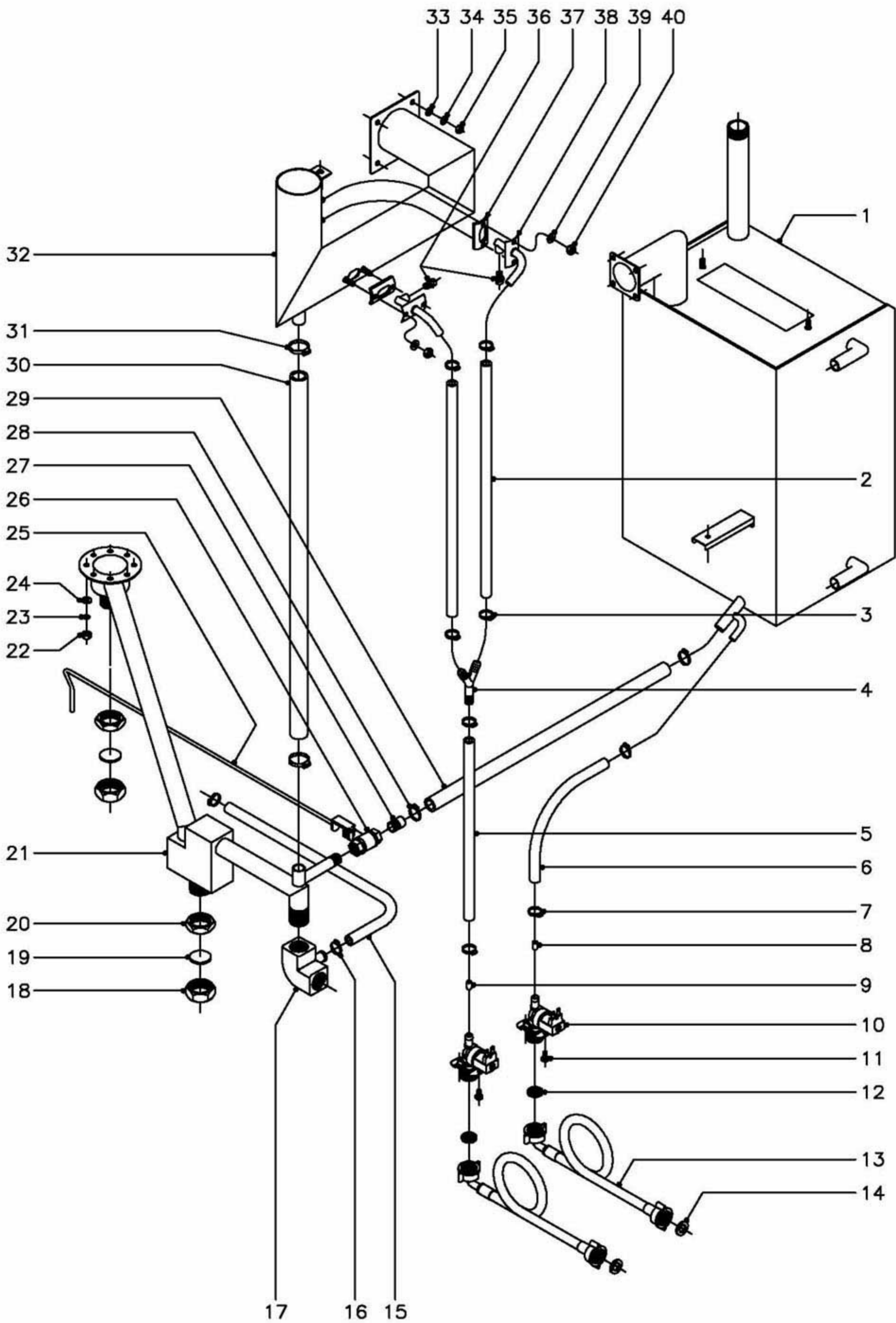

<b>ITEM</b>	<b>CODIGO</b>	<b>DENOMINACION</b>	<b>TEXTO</b>	<b>HVG-10/11</b>	<b>HVG-10/21</b>													<b>NOTAS</b>
1	T115000	Generador de vapor		1	1													
2	3676900	Tubo goma negra Ø17xØ10x400		2	2													
3	Q881302	Abrazadera 12 - 20		6	6													
4	Z201106	Racord en "Y"		1	1													
5	3676900	Tubo goma negra Ø17xØ10x500		1	1													
6	3676900	Tubo goma negra Ø17xØ10x700		1	1													
7	Q881302	Abrazadera 12 - 20		2	2													
8	Z601156	Regulador caudal 8 l./m. (rojo)		1	1													
9	P443042	Regulador caudal 3 l./m. (negro)		1	1													
10	Z701135	Electrovalvula entrada de agua		2	2													
11	Q032021	Tornillo alomado M-4x10		4	4													
12	Z701132	Filtro-junta entrada de agua		2	2													
13	Z601114	Manguera entrada de agua		2	2													
14	Q307031	Junta manguera Ø24xØ14x3		2	2													
15	3713100	Tubo silicona forrado Ø23xØ16x1000		1	1													
16	Q881304	Abrazadera 20 - 32		2	2													
17	R665067	Codo desagüe		1	1													
18	R665053	Tuerca tapon 1" laton		2	2													
19	R015011	Arandela junta Ø34x3		2	2													
20	Q223014	Contratuerca 1"		2	2													
21	T115017	Conjunto desagüe completo		1	-													
21	T125004	Conjunto desagüe completo		-	1													
22	Q162040	Tuerca exagonal M-6		8	8													
23	Q262040	Arandela muelle A-6		8	8													
24	Q232040	Arandela plana A-6		8	8													
25	R342803	Palanca grifo vaciado		1	-													
25	R032804	Palanca grifo vaciado		-	1													
26	R015034	Cuerpo grifo vaciado		1	1													
27	R345014	Manguito grifo vaciado		1	1													

MOD.

HORNOS A GAS HVG

ZONA

CONDUCCIONES AGUA, VAPOR Y DESAGUE

PLANO

C-1091

ITEM	CODIGO	DENOMINACION	TEXTO	HVG-10/11	HVG-10/21														NOTAS
28	Q881304	Abrazadera 20 - 32		2	2														
29	3713100	Tubo silicona forrado Ø23xØ16x750		1	1														
30	3713000	Tubo silicona forrado Ø28xØ20x500		1	1														
31	Q881304	Abrazadera 20 - 32		2	2														
32	T115020	Retorno de vapor completo		1	1														
33	Q232040	Arandela plana A-6		4	4														
34	Q242040	Arandela abanico A-6		4	4														
35	Q162040	Tuerca exagonal M-6		4	4														
36	T115086	Tobera R. 1/8" (Ø1,5)		2	2														
37	R725159	Junta tubo inyector		2	2														
38	T115112	Conduccion de vahos completa		2	2														
39	Q242030	Arandela abanico A-5		4	4														
40	Q162030	Tuerca exagonal M-5		4	4														



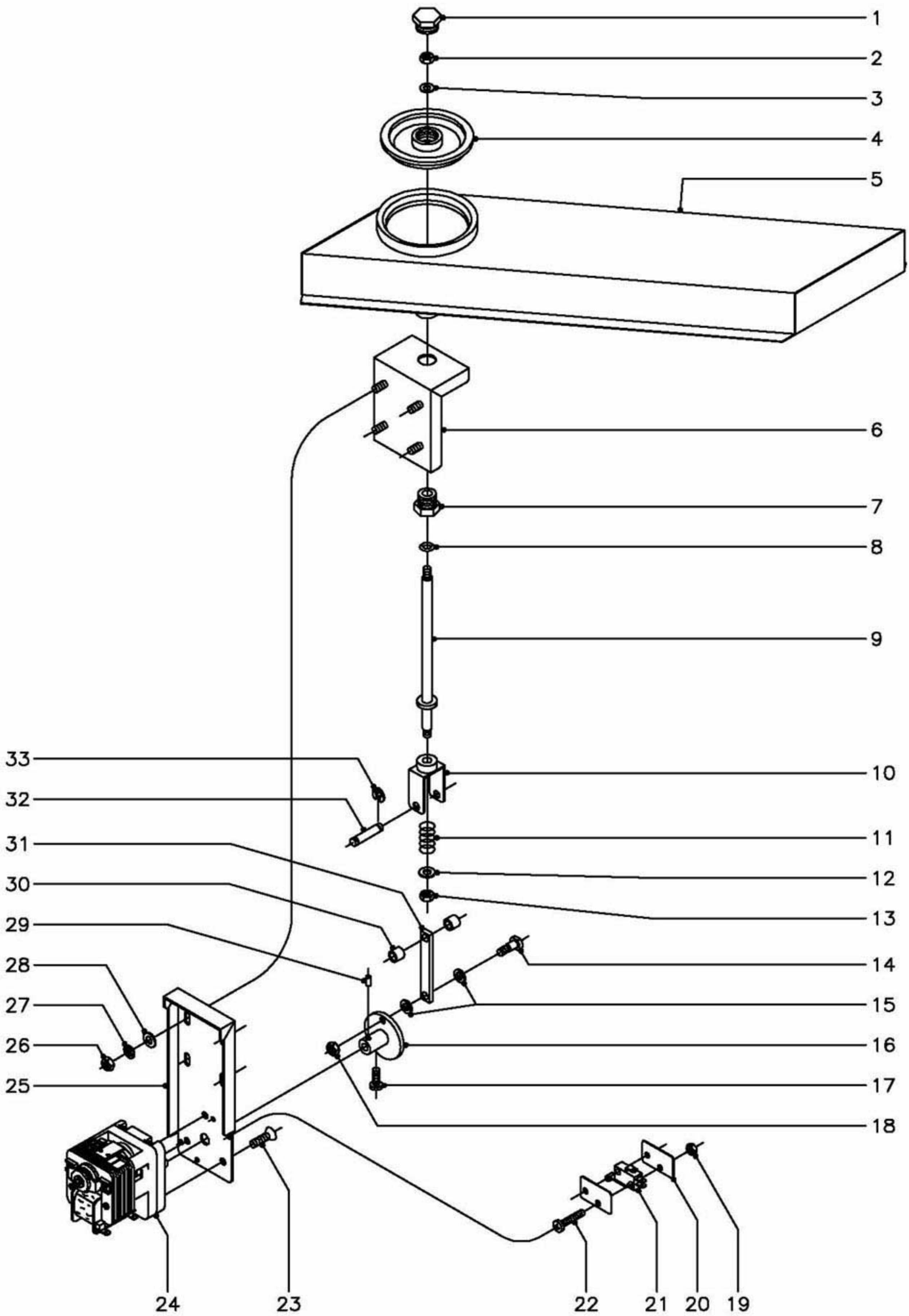

N plano	Firma	Fecha	Aparato	CIERRE CHIMENEA	Lamina	Fagor Industrial S.Coop. <b>FAGOR</b>
C-1092		10-2001	HORNOS A GAS HVG-10/11 Y 10/21	8	Oñate	

MOD.	HORNOS A GAS HVG	ZONA	CIERRE CHIMENEA	PLANO	C-1092
------	------------------	------	-----------------	-------	--------

ITEM	CODIGO	DENOMINACION	TEXTO	HVG-10/11	HVG-10/21									NOTAS
1	T115052	Tapon retencion vapores		1	1									
2	Q162040	Tuerca exagonal M-6		1	1									
3	Q232040	Arandela plana A-6		1	1									
4	T115050	Retencion vapores		1	-									
4	T125013	Retencion vapores		-	1									
5	T112612	Chimenea completa		1	-									
5	T122606	Chimenea completa		-	1									
	Q412002	Remache tubular Ø4x7,5		9	9									
6	T135022	Soporte amarre motor completo		1	1									
7	R725030	Tuerca guia retencion		1	1									
8	Q307067	Junta torica Ø14,43xØ9,19xØ2,62		1	1									
9	T135018	Eje retencion vapores		1	1									
10	T135020	Tensor retencion vapores		1	1									
11	R725008	Resorte		1	1									
12	Q302022	Arandela plana Ø16xØ6x1,2		1	1									
13	Q162040	Tuerca exagonal M-6		1	1									
14	T135009	Eje de leva		1	1									
15	Q308013	Arandela de teflon Ø14xØ8x2		2	2									
16	T135012	Leva		1	1									
17	Q012021	Tornillo exagonal M-4x10		1	1									
18	Q162040	Tuerca exagonal M-6		1	1									
19	Q161310	Tuerca exagonal M-3		4	4									
20	R010535	Placa separadora		4	4									
21	R010534	Interruptor puerta		2	2									
22	Q032013	Tornillo alomado M-3x20		4	4									
23	Q042031	Tornillo avellanado M-5x10		3	3									
24	T113010	Motor chimenea		1	1									
25	T135021	Escuadra amarre motor		1	1									
26	Q162040	Tuerca exagonal M-6		4	4									

MOD.

HORNOS A GAS HVG

ZONA



CIERRE CHIMENEA

PLANO

C-1092

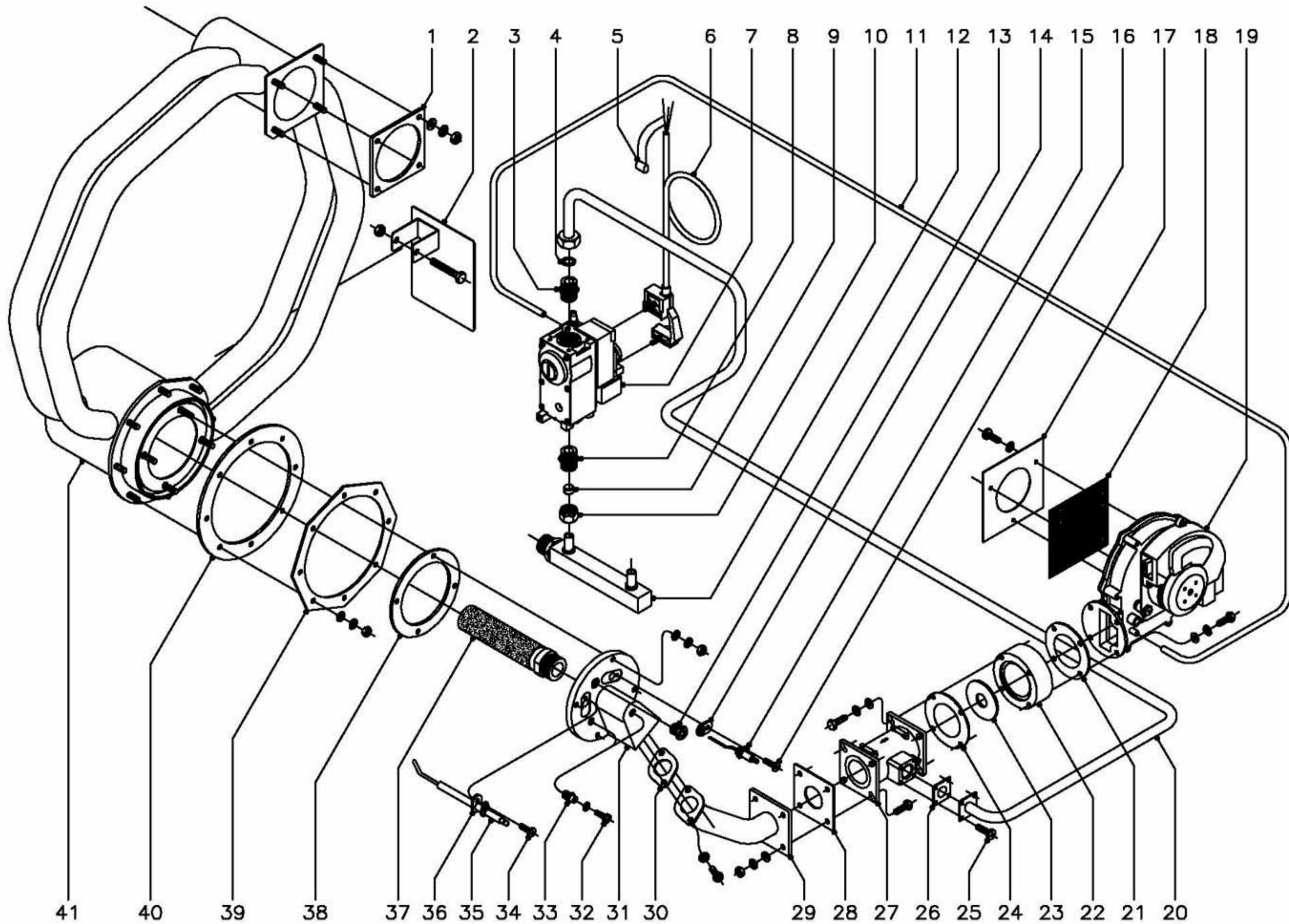
ITEM	CODIGO	DENOMINACION	TEXTO	HVG-10/11	HVG-10/21								NOTAS
27	Q242040	Arandela abanico A-6		4	4								
28	Q232040	Arandela plana A-6		4	4								
29	T115057	Pasador de leva		1	1								
30	T135011	Distanciador		2	2								
31	T135013	Palanca de elevacion		1	1								
32	T135010	Eje de tensor retencion vapores		1	1								
33	Q271033	Arandela de seguridad Ø6		2	2								



N plano C-1093	Firma 	Fecha 10-2001	Aparato PARTE FUNCIONAL GAS HORNOS A GAS HVG-10/11 Y 10/21	Lamina 9	Fagor Industrial S.Coop. <b>FAGOR</b> 
-------------------	--	------------------	--	-------------	---

MOD.

HORNOS A GAS HVG

ZONA

PARTE FUNCIONAL GAS

PLANO

C-1093

ITEM	CODIGO	DENOMINACION	TEXTO	HVG-10/11	HVG-10/21								NOTAS
1	R725052	Junta colector		2	2								
	Q232040	Arandela plana A-6		4	4								
	Q242040	Arandela abanico A-6		4	4								
	Q162040	Tuerca exagonal M-6		4	4								
2	R722629	Aleron intercambiador		3	4								
	Q012046	Tornillo exagonal M-6x40		3	4								
	Q162040	Tuerca exagonal M-6		3	4								
3	S205023	Manguito doble 1/2"		1	1								
4	Q306012	Arandela junta Ø18xØ13x1,5		1	1								
5	Z233012	Condensador antiparasitario		1	1								
6	T085012	Conector valvula Honeywell		1	1								
7	T115097	Valvula Honeywell ( Regulado a B.P.)		1	1								( 50 Hz.)
7	T115098	Valvula Honeywell ( Regulado a G.N.)		1	1								( 50 Hz.)
7	T115100	Valvula Honeywell ( Regulado a B.P.)		1	1								( 60 Hz.)
7	T115101	Valvula Honeywell ( Regulado a G.N.)		1	1								( 60 Hz.)
8	S205023	Manguito doble 1/2"		1	1								
9	U055043	Bicono Ø 12		1	1								
10	Q221336	Tuerca M-18x1,5 ( Para tubo Ø 12 )		1	1								
11	3702400	Tubo goma negra Ø 8xØ 4x1500		1	1								
12	T115015	Entrada de gas		1	1								
13	R725015	Visor de encendido		1	1								
14	R725079	Junta electrodo		1	1								
15	T115712	Electrodo de deteccion		1	1								
16	Q153021	Tornillo alomado M-4x10		1	1								
17	T115096	Chapa amarre malla ventilador		1	1								
	Q032021	Tornillo alomado M-4x10		3	3								
	Q242020	Arandela abanico A-4		3	3								
18	T115095	Malla ventilador		1	1								
19	T083000	Ventilador E.B.M.-RG130		1	1								

ITEM	CODIGO	DENOMINACION	TEXTO	HVG-10/11	HVG-10/21								NOTAS
20	T115078	Conduccion de gas completo		1	-								
20	T125021	Conduccion de gas completo		-	1								
21	T115081	Junta acoplamiento ventilador y mixe		1	1								
22	T115076	Acoplamiento ventilador mixer		1	1								
23	T115082	Arandela regulacion ventilador Ø 18		1	1								( Butano-Propano
23	T115083	Arandela regulacion ventilador Ø 20		1	1								( Gas Natural )
24	T115081	Junta acoplamiento ventilador y mixe		1	1								
25	Q032021	Tornillo alomado M-4x10		4	4								
26	T115080	Junta conduccion mixer		1	1								
27	T115075	Mixer 35 KW.		1	1								
28	T115079	Junta mixer conducto		1	1								
29	T115077	Conducto mixer tapa principal		1	1								
30	T095021	Junta conducto tapa		1	1								
31	R725710	Tapa principal		1	1								
32	Q152024	Tornillo avellanado M-4x8		2	2								
	R725061	Junta toma de presion		2	2								
33	R725017	Boquilla toma de presion		2	2								
34	Q153021	Tornillo alomado M-4x10		1	1								
35	T115711	Electrodo de ignicion		1	1								
36	R725079	Junta electrodo		1	1								
37	T115710	Quemador Furigas ( 10/11 y 10/21 )		1	1								
38	R725055	Junta de tapa principal		1	1								
39	-	Brida amarre intercambiador		-	-								Caldeado a cuerpo de horno
40	R725051	Junta camara combustion		1	1								
41	R725701	Intercambiador completo		1	1								

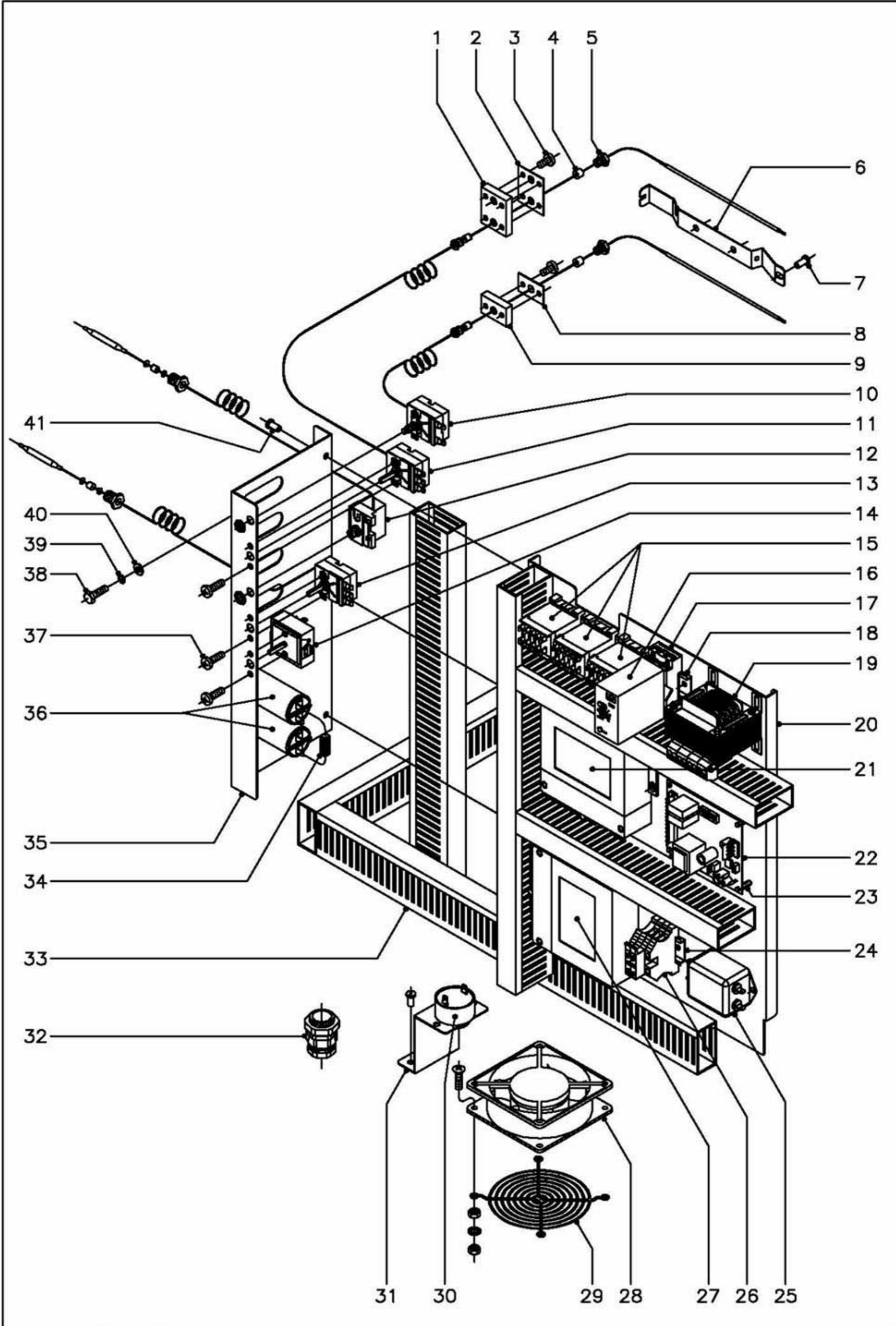

N plano C-1094	Firma 	Fecha 10-2001	Aparato CUADRO ELECTRICO HORNOS A GAS HVG-10/11 Y 10/21	Lamina 10	Fagor Industrial S.Coop. <b>FAGOR</b> Oñate
-------------------	-----------	------------------	---	--------------	--

MOD.		HORNOS A GAS HVG		ZONA		CUADRO ELECTRICO						PLANO		C-1094	
ITEM	CODIGO	DENOMINACION	TEXTO	HVG-10/11	HVG-10/21									NOTAS	
1	R662659	Pasamuros doble		1	1										
2	R692811	Junta pasamuros doble		1	1										
3	Q032021	Tornillo alomado M-4x10		6	6										
4	R662662	Junta cierre bulbo limitador		2	2										
5	R662629	Racord cierre sonda		2	2										
6	R662630	Soporte bulbo		2	2										
7	Q412002	Remache tubular Ø4x7,5		6	6										
8	R692812	Junta pasamuros simple		1	1										
9	T112625	Pasamuros simple		1	1										
10	R243016	Limitador temperatura horno		1	1										
11	R343018	Termostato horno		1	1										
12	Z953036	Termostato limitador generador		1	1										
13	R343100	Termostato generador ( 30 - 85°C.)		1	1										
14	S333001	Regulador de energia		1	1										
15	Z683087	Contactador 3TF20 01-3AL2 230V.		3	3										
16	R343072	Detector de niveles		1	1										
17	R743009	Base enchufable detector		1	1										
18	Z123019	Guia contactor L=175		1	1										
19	R503005	Transformador		1	1										
20	T133005	Panel cuadro electrico		1	1										
21	Z953004	Control combustion		1	1										
22	T083002	Variador de velocidad		1	1										
23	T133007	Distanciador M-3		4	4									Amarre variador a cuadro	
	T133008	Tornillo amarre M-3x23 ( plastico )		4	4									Amarre variador a cuadro	
	Q161310	Tuerca exagonal M-3		4	4									Amarre variador a cuadro	
24	Z123018	Guia contactor L=55		1	1										
25	T113023	Filtro de entrada modelo FF-6Z		1	1										
26	P453026	Borne tierra 10		1	1										
	R073005	Borna portafusibles		2	2										



MOD.

HORNOS A GAS HVG

ZONA

CUADRO ELECTRICO

PLANO

C-1094

ITEM	CODIGO	DENOMINACION	TEXTO	HVG-10/11	HVG-10/21														NOTAS
	R723015	Fusible cristal 10 A.		2	2														
	Z263303	Tope final		1	1														
27	Z953004	Control combustion		1	1														
28	Z103066	Ventilador 230 V., 50-60 Hz.		2	2														
29	T113015	Proteccion ventilador		2	2														
	Q042022	Tornillo avellanado M-4x15		8	8														
	Q242020	Arandela abanico A-4		8	8														
	Q162020	Tuerca exagonal M-4		16	16														
30	R693067	Zumbador		1	1														
31	T143001	Soporte zumbador		1	1														
	Q412002	Remache tubular Ø 4x7,5		2	2														
32	R073004	Prensaestopas		1	1														
33	3715520	Canaleta unex ( 60x30x longitud )		6	6														
34	R073008	Cableado PTC		1	1														
35	T133006	Apoyo componentes		1	1														
36	R293000	Condensador		2	2														
37	Q151320	Tornillo alomado M-4x6		6	6														
38	Q012042	Tornillo exagonal M-6x15		4	4														
39	Q262040	Arandela muelle A-6		4	4														
40	Q232040	Arandela plana A-6		4	4														
41	Q412002	Remache tubular Ø 4x7,5		3	3														

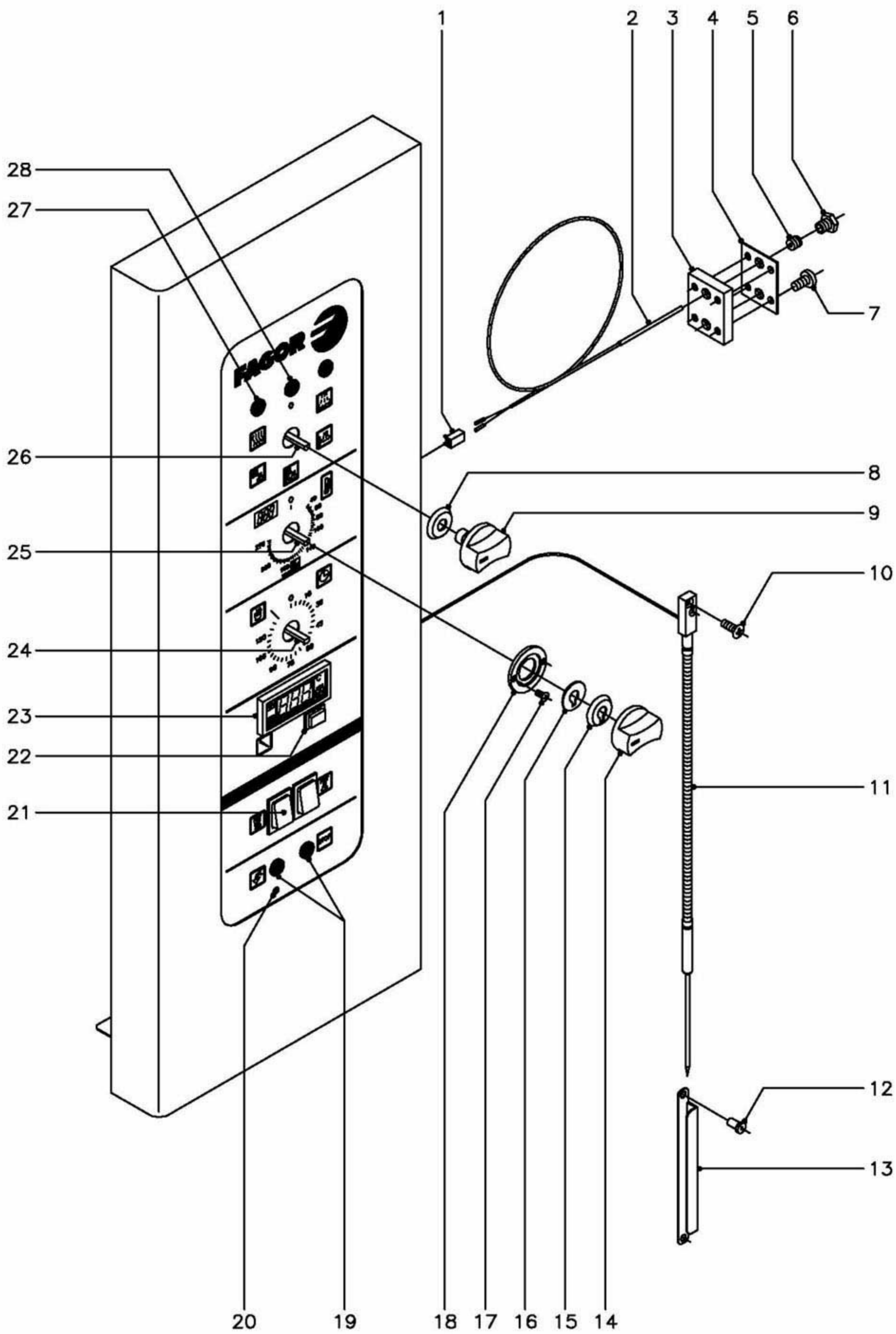

N plano  
C-1095

Firma

Fecha  
10-2001

Aparato PARTE ELECTRICA PORTAMANDOS  
HORNOS A GAS HVG-10/11 Y 10/21

Lamina  
11

Fagor Industrial S.Coop. **FAGOR**  
Oforte

MOD.

HORNOS A GAS HVG

ZONA

PARTE ELECTRICA PORTAMANDOS

PLANO

C-1095

ITEM	CODIGO	DENOMINACION	TEXTO	HVG-10/11	HVG-10/21														NOTAS
1	R663092	Conector 2 vias		1	1														
2	R663090	Conjunto termopar L=1400		1	1														
3	R662659	Pasamuros doble		1	1														
4	R692811	Junta pasamuros doble		1	1														
5	R662652	Bicono cierre sonda		1	1														
6	R662629	Racord cierre sonda		1	1														
7	Q032021	Tornillo alomado M-4x10		4	4														
8	R663046	Junta ( conmutadores )		2	2														
9	R663062	Boton de mando Ø6 ( conmutadores )		2	2														
10	Q042022	Tornillo avellanado M-4x15		2	2														
11	T113007	Conjunto sonda nucleo		1	1														
12	Q412002	Remache tubular Ø 4x7,5		2	2														
13	R672643	Soporte de sonda		1	1														
14	R663063	Boton de mando Ø6 (termos.electro.)		1	1														
15	R663045	Junta (termostato electronico )		1	1														
16	R662810	Arandela guia		1	1														
17	Q151346	Tornillo avellanado M-3x5		2	2														
18	R662809	Guia boton de mando		1	1														
19	Z953034	Piloto rojo		2	2														
20	Z953035	Termostato limitador aviso		1	1														
21	Z213033	Pulsador rearme generador y horno		2	2														
22	R743008	Interruptor regulacion sonda		1	1														
23	T133004	Termostato digital tipo K		1	1														
24	R723000	Temporizador manual		1	1														
25	R743013	Termostato electronico 0 - 270° C.		1	1														
	R663036	Fijacion circuito termost. electroni.		4	4														
26	T113030	Conmutador de funciones		1	1														
27	Z203005	Piloto ambar		2	2														
28	Z203004	Piloto verde		1	1														

MOD.

HORNOS A GAS HVG

ZONA

VARIOS

PLANO

ITEM

CODIGO

DENOMINACION

TEXTO

HVG-10/11

HVG-10/21

NOTAS

T116502

Folleto de instrucciones

1

1

T113031

Esquema electrico adhesivo

1

1

Plano HC-75606

T113028

Leyenda esquema electrico

1

1

Plano HC-75483

T113029

Instalacion electrica

1

1

T113021

Cableado luz interior

1

1

R663094

Cableado luz puerta

1

1

3713900

Funda roja o negra Ø 6,4x500

1

1

T113022

Cable de encendido L=500

1

-

T123000

Cable de encendido L=700

-

1

T113033

Cable de encendido L=2000

1

-

T123010

Cable de encendido L=2200

-

1

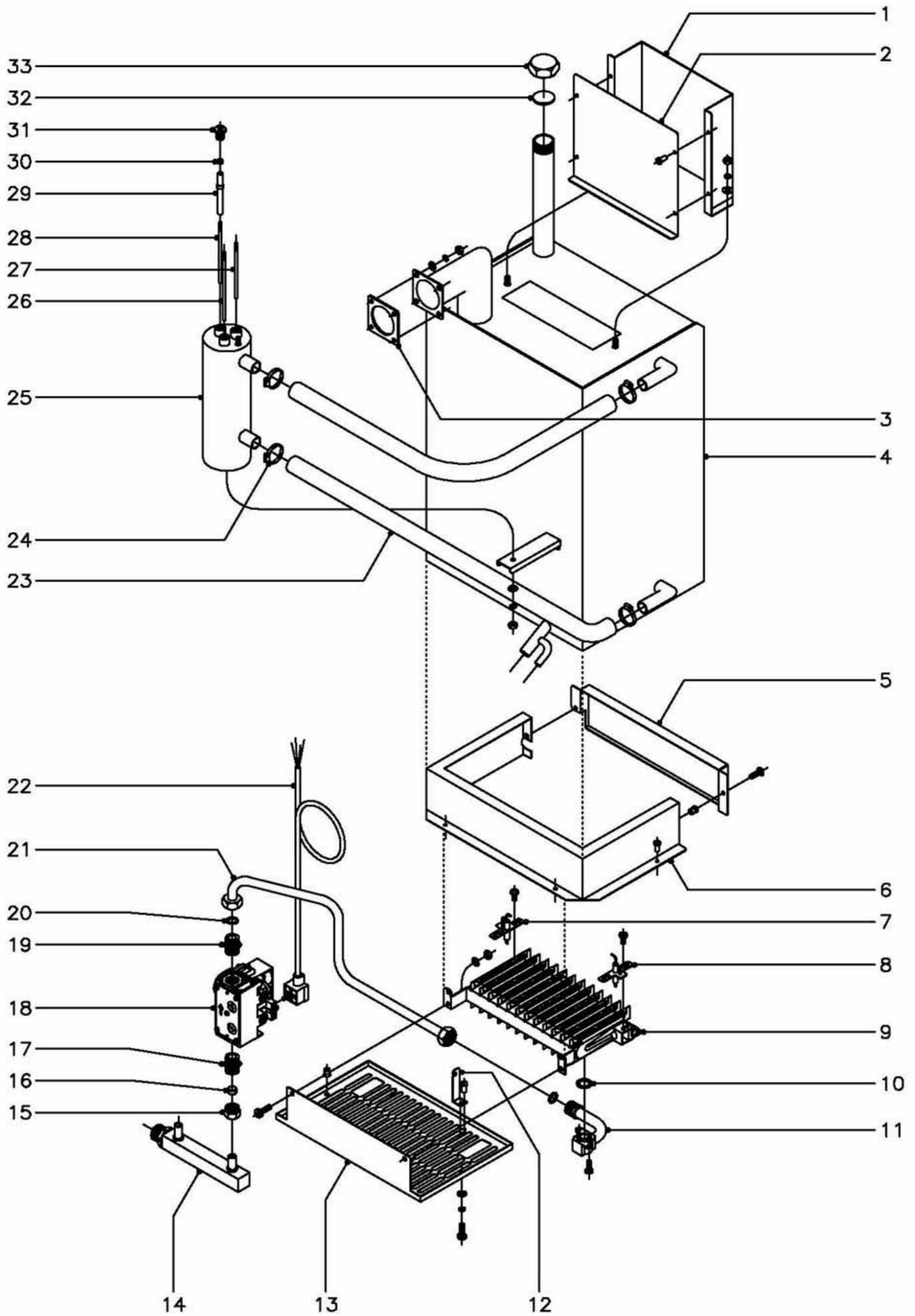

N plano  
C-1090

Firma

Fecha  
10-2001

Aparato  
GENERADOR DE VAPOR  
HORNOS A GAS HVG-10/11 Y 10/21

Lamina  
6

Fagor Industrial S.Coop. **FAGOR**  
Orate

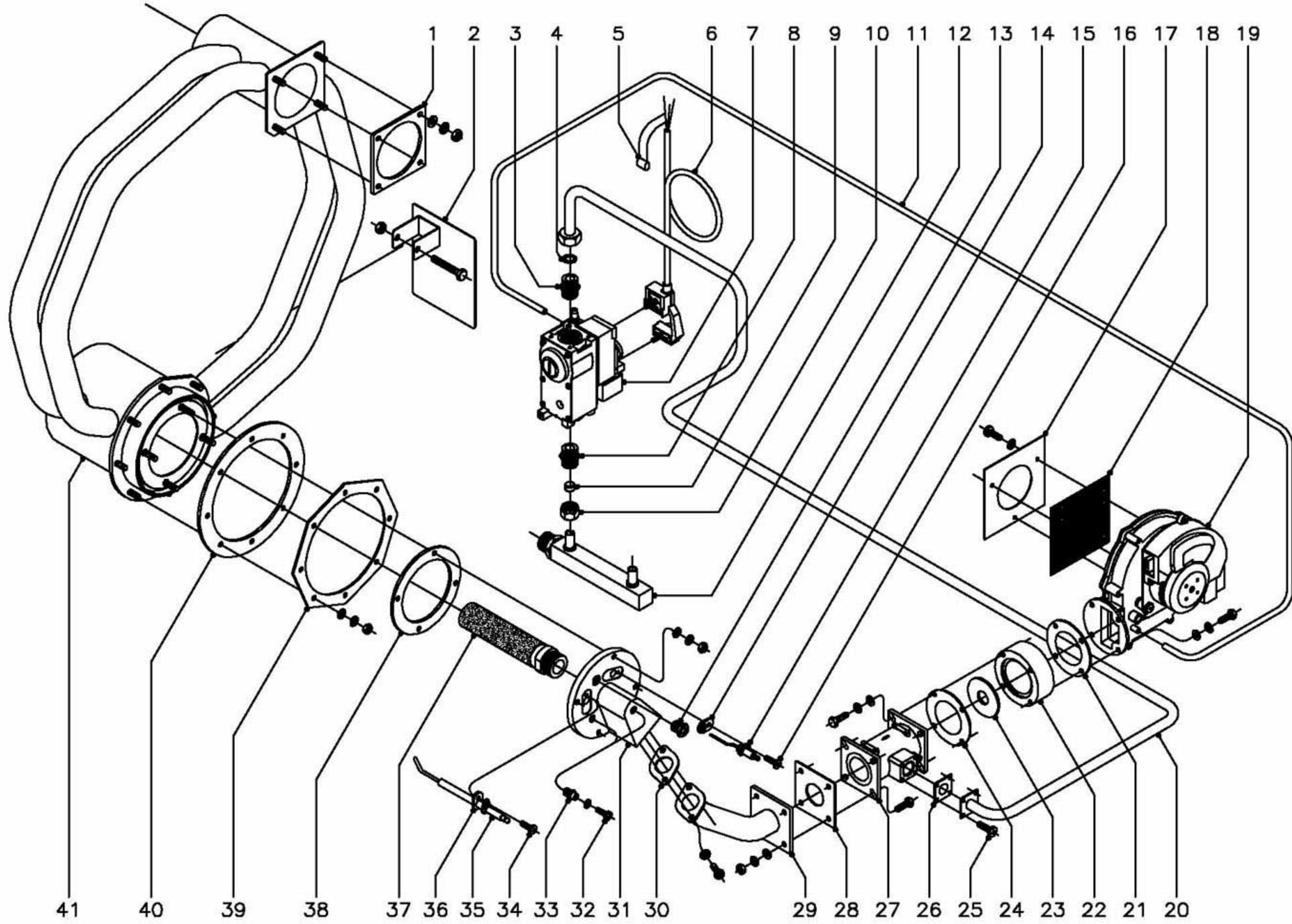

N plano	Firma	Fecha	Aparato	PARTE FUNCIONAL GAS	Lamina	Fagor Industrial S.Coop. <b>FAGOR</b>
C-1093		10-2001	HORNOS A GAS HVG-10/11 Y 10/21		9	Oñate

ITEM	CODIGO	DENOMINACION	TEXTO	HVG-10/11	HVG-10/21	HVG-2-10/11	HVG-10/11A	HVG-10/21A	HVG-2-10/11A							NOTAS
<b><u>BUTANO - PROPANO 50 Hz.</u></b>																
s/n	Z955899	Inyector Ø 0,7 (En quemador item 9)		12	12		12	12								Plano C-1090
18	Z952201	Valvula SIT-830 50 Hz. (B.P.y G.N.)		1	1		1	1								Plano C-1090
7	T115097	Valvula Honeywell 50Hz. (B.P.)		1	1		1	1								Plano C-1093
22	T115082	Arandela regulacion ventilador Ø 18		1	1		1	1								Plano C-1093
<b><u>BUTANO - PROPANO 60 Hz.</u></b>																
s/n	Z955899	Inyector Ø 0,7 (En quemador item 9)		12	12		12	12								Plano C-1090
18	Z953501	Valvula SIT-830 60 Hz. (B.P.y G.N.)		1	1		1	1								Plano C-1090
7	T115100	Valvula Honeywell 60Hz. (B.P.)		1	1		1	1								Plano C-1093
22	T115082	Arandela regulacion ventilador Ø 18		1	1		1	1								Plano C-1093
<b><u>GAS NATURAL 50 Hz.</u></b>																
s/n	Z956104	Inyector Ø 1,1 (En quemador item 9)		12	12		-	-								Plano C-1090
s/n	Z956109	Inyector Ø 1,2 (En quemador item 9)		-	-		12	12								Plano C-1090
18	Z952201	Valvula SIT-830 50 Hz. (B.P.y G.N.)		1	1		1	1								Plano C-1090
7	T115098	Valvula Honeywell 50Hz. (G.N.)		1	1		1	1								Plano C-1093
22	T115083	Arandela regulacion ventilador Ø 20		1	1		1	1								Plano C-1093
<b><u>GAS NATURAL 60 Hz.</u></b>																
s/n	Z956104	Inyector Ø 1,1 (En quemador item 9)		12	12		12	12								Plano C-1090
18	Z953501	Valvula SIT-830 60 Hz. (B.P.y G.N.)		1	1		1	1								Plano C-1090
7	T115101	Valvula Honeywell 60Hz. (G.N.)		1	1		1	1								Plano C-1093
22	T115083	Arandela regulacion ventilador Ø 20		1	1		1	1								Plano C-1093

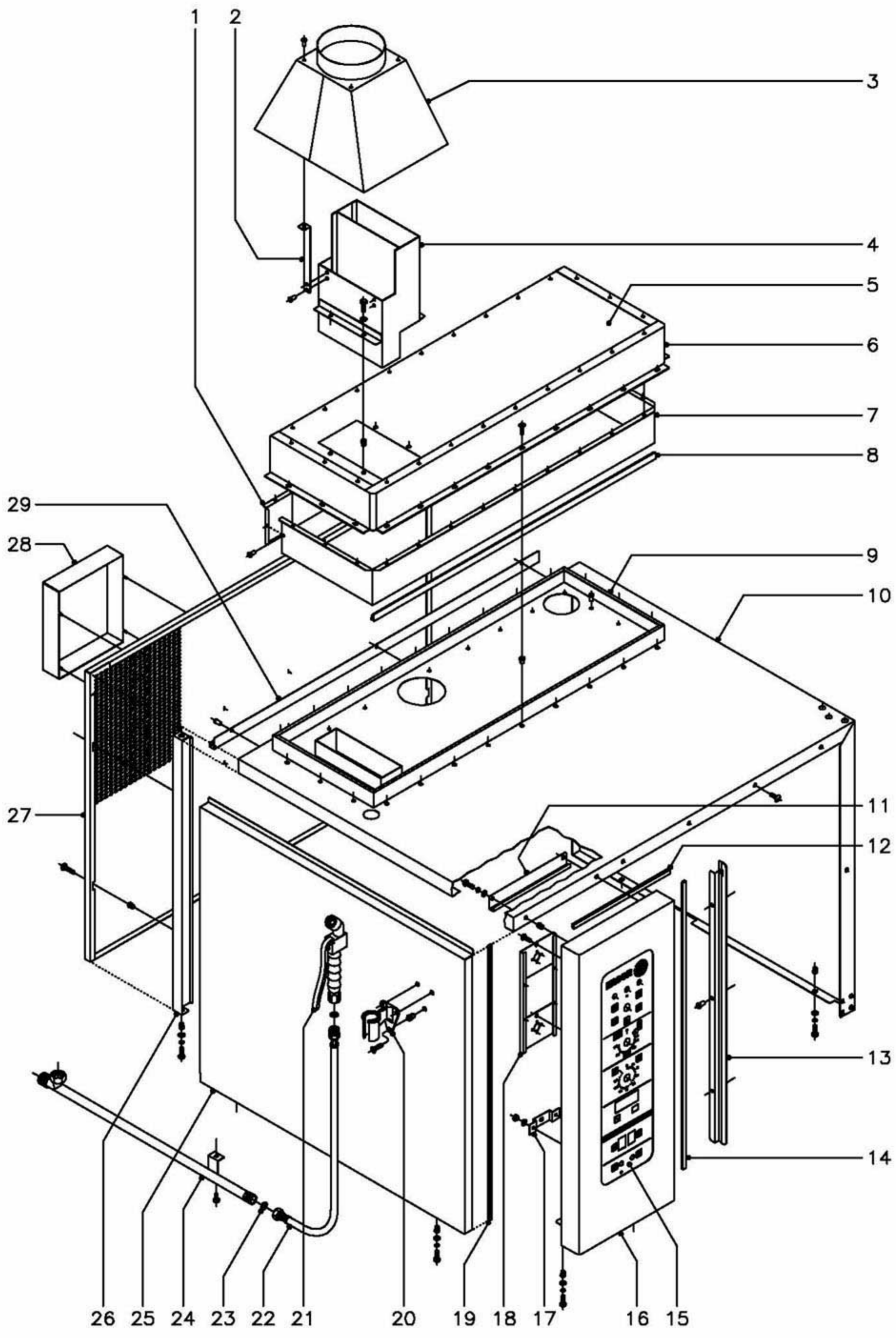

N plano	Firma	Fecha	Aparato	MUEBLE	Lamina	Fogor Industrial S.Coop. <b>FAGOR</b>
C-1085		10-2001	HORNOS A GAS HVG-10/11 Y 10/21		1	Onate



MOD.

HORNOS A GAS HVG  
HORNOS A GAS VGT ( VAUBAN )

ZONA

SERIGRAFIA PORTAMANDOS ( VAUBAN )

PLANO

C-1085

ITEM	CODIGO	DENOMINACION	TEXTO	HVG-10/11 VGT-10/11	HVG-10/21 VGT-10/21								NOTAS
15	T113025	Serigrafia VGT -VAUBAN		1	1								

HVG-10/11 HVG-10/21 HVG-20/11 HVG-20/21

IG	1	2	3	4	5	6	7	8	9	10
0			X							
1	X	X		X		X	X			
2	X	X		X			X			
3	X	X		X	X			X	X	X
4	X	X		X	X			X		X
5	X	X	X						X	

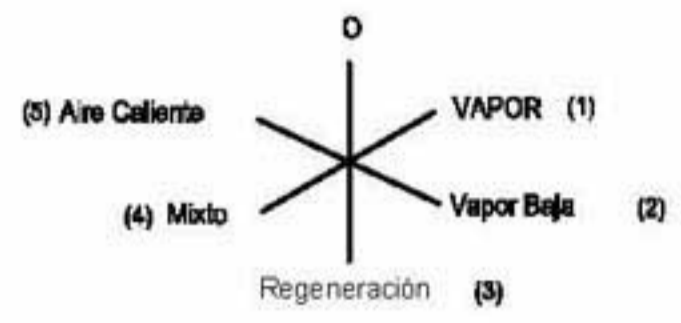
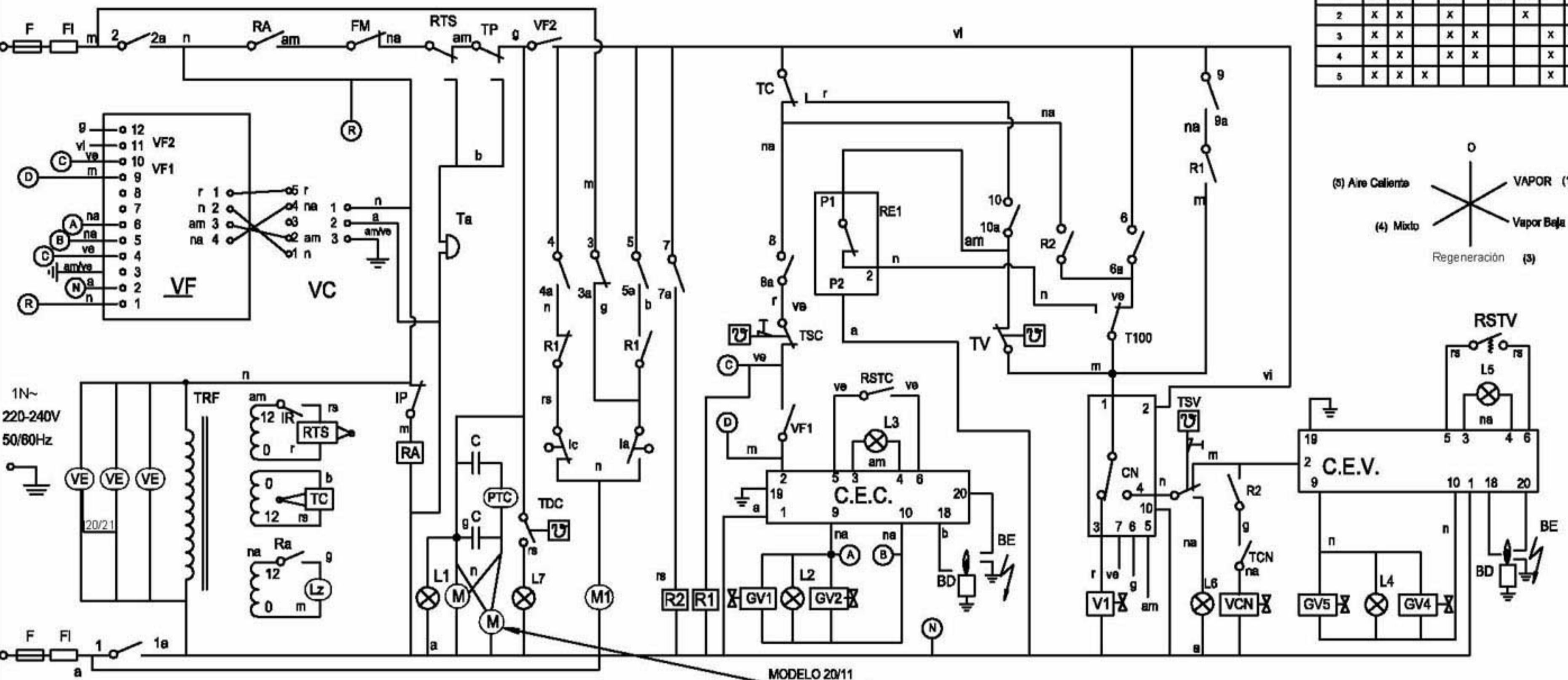

MODELO 20/11

T-113031

Esquema teorico adhesivo			T-113031	
Nº	Cant.	Material	Nº Clasificación	Acabado
Nº	Modificación	Propuesta de	Fecha	Tolerancias generales
1	Introducir VE	Maillo	16/10/2001	$\leq 5\pm$ : 50-100± : 5-25± : > 100± 25-50± : $\infty\pm$
Dibujado: Firma KONTXI, Fecha 22/2/01 Proyecto: Comprobado: Escala: 5			 Fagor Industrial, Koop. Eik, Mugatua Mecanizado superficial	
Plano numero <b>HC-75606-01</b> Sustituye al Nº HC-75448 Sustituido por				

# ESPAÑOL

## CODIGO DE COLORES:

r = rojo  
 a = azul  
 m = marron  
 g = gris  
 n = negro  
 b = blanco  
 vi = violeta  
 am = amarillo  
 na = naranja  
 rs = rosa  
 ve = verde  
 am/ve = amarillo verde

## COMPONENTES:

BD = Bujia de detector de llama  
 BE = Bujia de Encendido  
 C = Condensador Motor  
 C.E.C. = Control Encendido cámara  
 C.E.V. = Control encendido vapor  
 CN = Control nivel de agua  
 F, F1, F2, F3 = Fusible  
 FI = Filtro interferencias  
 FM = Térmico Motor  
 GV1 = Electroválvula de gas cámara (Control)  
 GV2 = Electroválvula de gas cámara (Seguridad)  
 GV4 = Electroválvula de gas vapor (Control)  
 GV5 = Electroválvula de gas vapor (Seguridad)  
 la = Micro chimenea abierta  
 lc = Micro chimenea cerrada  
 IG = Interruptor general  
 IP = Interruptor puerta  
 IR = Selector regulador sonda núcleo  
 L1 = Lámpara de funcionamiento  
 L2 = Lámpara calentamiento cámara  
 L4 = Lámpara entrada de vapor  
 L3 = Lámpara indicador de bloqueo cámara  
 L5 = Lámpara indicador de bloqueo vapor  
 L6 = Lámpara seguridad de vapor  
 L7 = Lámpara detección de cal  
 LZ = Luz interior cámara  
 M = Motor  
 M1 = Motor accionamiento chimenea  
 R2, R1, Ra = Relé Auxiliar  
 RE1 = Regulador de energía  
 RSTC = Pulsador de rearme cámara  
 RSTV = Pulsador de rearme vapor  
 RTS = Regulador sonda núcleo  
 T100 = Termostato fijo 100°C  
 Ta = Timbre avisador  
 TC = Termostato cámara  
 TCN = Termostato condensación  
 TDC = Termostato detección de cal  
 TP, TMP = Temporizador  
 TRF, TRF1 = Transformador  
 TSC = Termostato seguridad cámara  
 TSV = Termostato seguridad de vapor  
 TV = Termostato de vapor  
 V1 = Electroválvula de agua de llenado  
 VC = Ventilador centrifugo premezcla  
 VCN = Electroválvula de agua de condensación  
 VE = Ventilador cuadro eléctrico  
 VF = Variador de frecuencia

# FRANÇAIS

## CODES DE COULEURS:

r = rouge  
 a = bleu  
 m = marron  
 g = gris  
 n = noir  
 b = blanc  
 vi = violet  
 am = jaune  
 na = orange  
 rs = rose  
 ve = vert  
 am/ve = jaune/vert

## COMPOSANTS:

BD = Veilleuse de détection de flamme  
 BE = Veilleuse d'allumage  
 C = Condensateur moteur  
 C.E.C. = Contrôle d'allumage de chambre  
 C.E.V. = Contrôle d'allumage de vapeur  
 CN = Contrôle du niveau d'eau  
 F, F1, F2, F3 = Fusible  
 FI = Filtre interférences  
 FM = Moteur thermique  
 GV1 = Electrovalve de chambre gaz (contrôle)  
 GV2 = Electrovalve de chambre gaz (sécurité)  
 GV4 = Electrovalve de vapeur gaz (contrôle)  
 GV5 = Electrovalve de vapeur gaz (sécurité)  
 la = Micro cheminée ouverte  
 lc = Micro cheminée fermée  
 IG = Interruptor general  
 IP = Interrupteur de porte  
 IR = Sélecteur régulateur de sonde noyau  
 L1 = Lampe de fonctionnement  
 L2 = Lampe de chauffe chambre  
 L4 = Lampe d'arrivée de vapeur  
 L3 = Lampe témoin de blocage de chambre  
 L5 = Lampe témoin de blocage de vapeur  
 L6 = Lampe de sûreté de vapeur  
 L7 = Lampe de détection de calcaire  
 LZ = LumiÈre intérieure de chambre  
 M = Moteur  
 M1 = Actionnement moteur de cheminée  
 R2, R1, Ra = Relais auxiliaire  
 RE1 = Régulateur d'énergie  
 RSTC = Bouton de réarmement de chambre  
 RSTV = Bouton de réarmement de vapeur  
 RTS = Régulateur de sonde noyau  
 T100 = Thermostat fixe 100°C  
 Ta = Sonnerie d'alarme  
 TC = Thermostat de chambre  
 TCN = Thermostat de condensation  
 TDC = Thermostat de détection de calcaire  
 TP, TMP = Temporisateur 0-120  
 TRF, TRF1 = Transformador  
 TSC = Thermostat de sûreté de chambre  
 TSV = Thermostat de sûreté de vapeur  
 TV = Thermostat de vapeur  
 V1 = Electrovalve de remplissage d'eau  
 VC = Ventilateur de centrifugeuse de prémélange  
 VCN = Electrovalve de condensation d'eau  
 VE = Ventilateur tableau électrique  
 VF = Variador de frecuencia

# ENGLISH

## COLOUR CODE

r = red  
 a = blue  
 m = brown  
 g = grey  
 n = black  
 b = white  
 vi = violet  
 am = yellow  
 na = orange  
 rs = pink  
 ve = green  
 am/ve = yellow-green

## COMPONENTS:

BD = Flame detector spark plug  
 BE = Ignition spark plug  
 C = Motor condenser  
 C.E.C. = Cooking chamber ignition control  
 C.E.V. = Steam ignition control  
 CN = Water level control  
 F, F1, F2, F3 = Fusible  
 FI = Interference filter  
 FM = Motor thermal switch  
 Cooking chamber gas solenoid valve (control)  
 GV2 = Cooking chamber gas solenoid valve (safety)  
 GV4 = Steam gas solenoid valve (control)  
 GV5 = Steam gas solenoid valve (safety)  
 la = Chimney open microswitch  
 lc = Chimney closed microswitch  
 IG = Interruptor general  
 IP = Door switch  
 IR = Core probe regulator selector  
 L1 = On/off lamp  
 L2 = Cooking chamber heating lamp  
 L4 = Steam inlet lamp  
 L3 = Cooking chamber lock indicator lamp  
 L5 = Steam lock indicator lamp  
 L6 = Steam safety lamp  
 L7 = Lime detection lamp  
 LZ = Cooking chamber interior lamp  
 M = Motor  
 M1 = Chimney drive motor  
 R2, R1, Ra = Auxiliary relay  
 RE1 = Energy regulator  
 RSTC = Cooking chamber reset button  
 RSTV = Steam reset button  
 RTS = Core probe regulator  
 T100 = Fixed 100°C thermostat  
 Ta = Warning buzzer  
 TC = Cooking chamber thermostat  
 TCN = Condensation thermostat  
 TDC = Lime detection thermostat  
 TP, TMP = 0-120 timer  
 TRF, TRF1 = Transformer  
 TSC = Cooking chamber safety thermostat  
 TSV = Steam safety thermostat  
 TV = Steam thermostat  
 V1 = Water filling solenoid valve  
 VC = Pre-mix centrifuge fan  
 VCN = Condensation water solenoid valve  
 VE = Switchboard fan  
 VF = Frequency inverter

# DEUTSCH

## FARBENCODE

r = rot  
 a = blau  
 m = braun  
 g = grau  
 n = schwarz  
 b = weiss  
 vi = violett  
 am = gelb  
 na = orangefarben  
 rs = rosa  
 ve = grün  
 am/ve = gelb/grün

## KOMPONENTEN:

BD = Zündkerze des Flammendetektors  
 BE = Zündkerze der Zündung  
 C = Motorkondensator  
 C.E.C. = Zündkontrolle Kammer  
 C.E.V. = Zündkontrolle Dampf  
 CN = Kontrolle Wasserstand  
 F, F1, F2, F3 = Fusible  
 FI = Interferenzefilter  
 FM = Thermomoter  
 GV1 = Electroventil Gas, Kammer (Kontrolle)  
 GV2 = Electroventil Gas, kammer (Sicherheit)  
 GV4 = Electroventil Gas, Dampf (Kontrolle)  
 GV5 = Electroventil Gas, Dampf (Sicherheit)  
 la = Mikroschacht geöffnet  
 lc = Mikroschacht geschlossen  
 IG = Hauptschalter  
 IP = Turschalter  
 IR = Wahlregler Kernsonde  
 L1 = Funktionsleuchtanzeige  
 L2 = Erwärmungsleuchtanzeige Kammer  
 L4 = Leuchtanzeige Dampfeintritt  
 L3 = Leuchtanzeige Blockierung Kammer  
 L5 = Leuchtanzeige Blockierung Dampf  
 L6 = Sicherheitsleuchtanzeige Dampf  
 L7 = Kalkanzeige  
 LZ = Innenbeleuchtung Kammer  
 M = Motor  
 M1 = Motorantrieb Mikroschacht  
 R2, R1, Ra = Relé Auxiliar  
 RE1 = Hilfsrelais  
 RSTC = Bedienungstaste Durch, Aufladung Kammer  
 RSTV = Bedienungstaste Durch, Aufladung Dampf  
 RTS = Kernsondenregler  
 T100 = Thermostat auf 100°C  
 Ta = Meldeklöngel/Lautwerk  
 TC = Thermostat Kammer  
 TCN = Kondensationsthermostat  
 TDC = Thermostat Kalkanzeige  
 TP, TMP = Zeitschalter 0-120  
 TRF, TRF1 = Transformator  
 TSC = Sicherheitsthermostat Kammer  
 TSV = Sicherheitsthermostat Dampf  
 TV = Dampftthermostat  
 V1 = Elektroventil Wasserfüllung  
 VC = Zentrifugallüfter Vormischung  
 VCN = Elektroventil Kondenswasser  
 VE = Schalttafelventilator  
 VF = Frequenzwandler

# ITALIANO

## CODICE DEI COLORI:

r = rosso  
 a = azzurro  
 m = marrone  
 g = grigio  
 n = nero  
 b = bianco  
 vi = viola  
 am = giallo  
 na = arancione  
 rs = rosa  
 ve = verde  
 am/ve = giallo/verde

## COMPONENTI:

BD = Candela del rilevatore di fiamma  
 BE = Candela d'accensione  
 C = Condensatore motore  
 C.E.C. = Controllo accensione cabina  
 C.E.V. = Controllo accensione vapore  
 CN = Controllo livello d'acqua  
 F, F1, F2, F3 = Fusibile  
 FI = Filtro interferenze  
 FM = Termico Motore  
 GV1 = Elettrovalvola gas cabina (controllo)  
 GV2 = Elettrovalvola gas cabina (sicurezza)  
 GV4 = Elettrovalvola gas vapore (controllo)  
 GV5 = Elettrovalvola gas vapore (sicurezza)  
 la = Micro camino aperto  
 lc = Micro camino chiuso  
 IG = Interruttore generale  
 IP = Interruttore porta  
 IR = Selettore regolatore sonda nucleo  
 L1 = Lampadina di funzionamento  
 L2 = Lampadina riscaldamento cabina  
 L4 = Lampadina ingresso vapore  
 L3 = Lampadina indicatore di blocco cabina  
 L5 = Lampadina indicatore di blocco vapore  
 L6 = Lampadina di sicurezza vapore  
 L7 = Lampadina rilevatore di calcare  
 LZ = Luce interna cabina  
 M = Motore  
 M1 = Motore funzionamento camino  
 R2, R1, Ra = Relais ausiliario  
 RE1 = Regolatore d'energia  
 RSTC = Pulsante di riarmo vapore  
 RSTV = Regolatore sonda nucleo  
 RTS = Regolatore Sonda Nucleo  
 T100 = Termostato fisso 100°C  
 Ta = Campanello avvisatore  
 TC = Termostato cabina  
 TCN = Termostato condensazione  
 TDC = Termostato rilevatore di calcare  
 TP, TMP = Timer 0-120  
 TRF, TRF1 = Transformador  
 TSC = Termostato sicurezza cabina  
 TSV = Termostato sicurezza vapore  
 TV = Termostato vapore  
 V1 = Elettrovalvola acqua di riempimento  
 VC = Ventilatore centrifuga  
 VCN = Elettrovalvola acqua di condensazione  
 VE = Ventilatore quadro elettrico  
 VF = Variatore di frequenza