

**Hornos Conveccion a Gas
Fours Air ulsé à Gaz
Gas Convection Ovens
Gas-Konvektionsöfen
Forni a Convezione a Gas**

Modelos:

**HCG-6/11
HCG-10/11
HCG-10/21
HCG-2.10/11**

**VCG-6/11
VCG-10/11
VCG-10/21
VCG-2.10/11**

Mayo 2003 May



Fagor Industrial

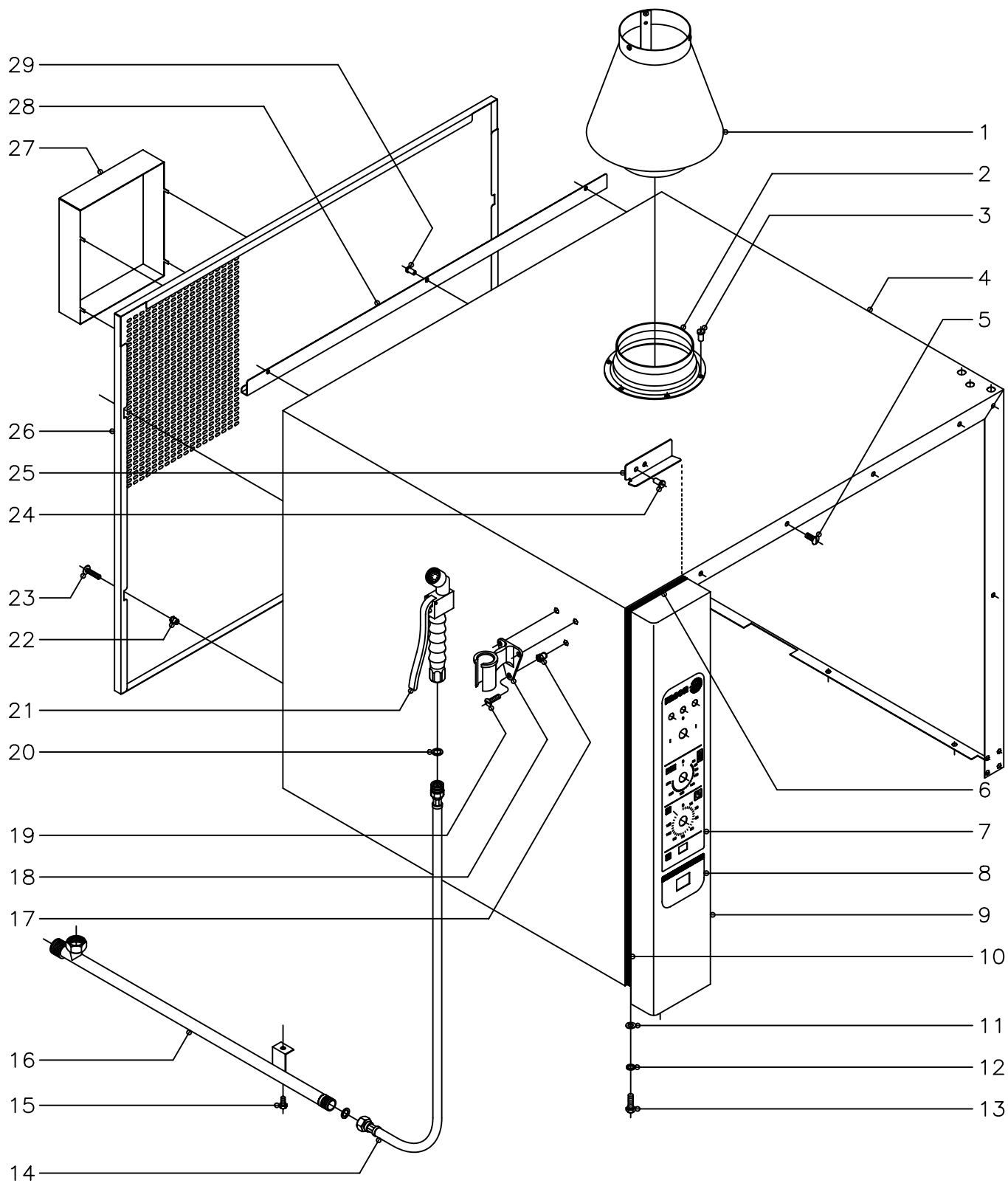

N plano
C-1339

Firma
[Signature]

Fecha
5-2003

Aparato
MUEBLE
HORNOS A GAS HCG-6/11,10/11,10/21

Lamina
1

Fagor Industrial S.Coop. **FAGOR**
Onate

MOD.		HORNOS A GAS HCG		ZONA	MUEBLE						PLANO	C-1339	
ITEM	CODIGO	DENOMINACION	TEXTO	HCG-6/11	HCG-10/11	HCG-10/21	HCG-2-10/11						NOTAS
1	R272612	Chimenea		1	1	1							
	R292646	Conducto humos		1	1	1							
	R272614	Soporte chimenea		3	3	3							
	Q412002	Remache tubular Ø 4x7,5		9	9	9							
2	R292645	Guia chimenea		1	1	1							
3	Q412000	Remache tubular Ø 4x8		6	6	6							
4	T082805	Cuerpo exterior de horno		1	-	-							
4	T012806	Cuerpo exterior de horno		-	1	-							
4	T022801	Cuerpo exterior de horno		-	-	1							
5	Q152017	Tornillo amarre M-6x13		5	6	6							
6	3715400	Junta panel portamandos L=130		1	1	1							
7	T013006	Serigrafia superior		1	1	1							
8	R723008	Serigrafia inferior		1	1	1							
9	T082810	Panel portamandos		1	-	-							
9	T012809	Panel portamandos		-	1	1							
10	3715400	Junta panel portamandos L=530		2	-	-							
10	3715400	Junta panel portamandos L=770		-	2	2							
11	Q232040	Arandela plana A-6		8	8	8							
12	Q262040	Arandela muelle A-6		8	8	8							
13	Q012042	Tornillo exagonal M-6x15		8	8	8							
14	R095006	Flexible de ducha		1	1	1							Opcional bajo pedido
15	Q012042	Tornillo exagonal M-6x15		1	1	1							Opcional bajo pedido
16	R675002	Suplemento ducha		1	1	-							Opcional bajo pedido
16	R685003	Suplemento ducha		-	-	1							Opcional bajo pedido
17	Q221342	Remache exagonal M-4		3	3	3							Opcional bajo pedido
18	R095007	Soporte de ducha		1	1	1							Opcional bajo pedido
19	Q042022	Tornillo avellanado M-4x15		3	3	3							Opcional bajo pedido
20	-	Arandela junta (con cuerpo ducha)		2	2	2							Opcional bajo pedido
21	R095005	Cuerpo de ducha		1	1	1							Opcional bajo pedido

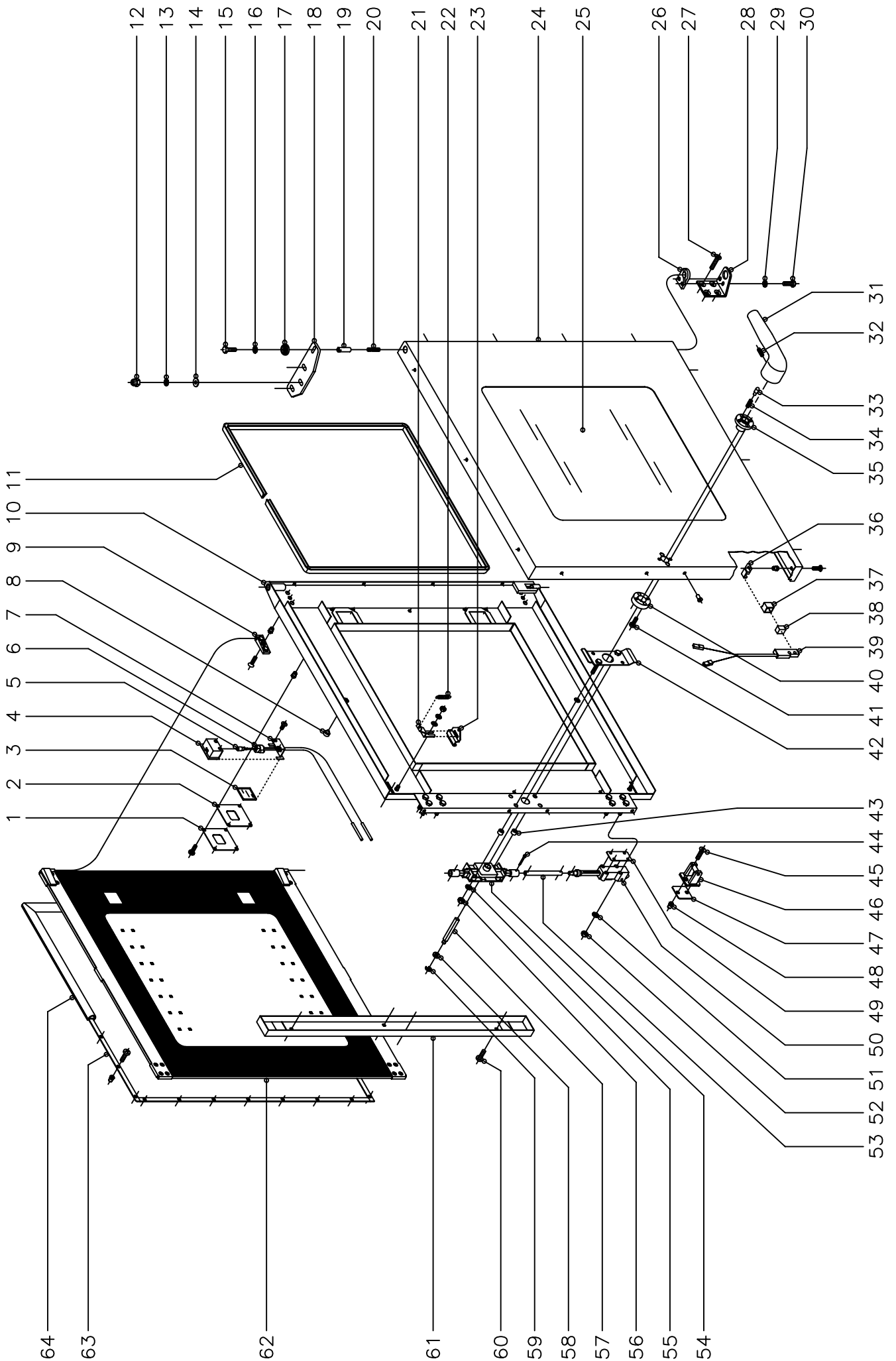

N plano
C-1340

Firma
[Signature]

Fecha
5-2003

Aparato
PUERTA
HORNOS A GAS HCG-6/11,10/11,10/21

Lamina
2

Fagor Industrial S.Coop. **FAGOR**
Ofate

MOD.		HORNOS A GAS HCG		ZONA	PUERTA						PLANO	C-1340	
ITEM	CODIGO	DENOMINACION	TEXTO	HCG-6/11	HCG-10/11	HCG-10/21	HCG-2-10/11						NOTAS
	1100002594	KIT Puerta completa 6/11		1	-	-							
	1100002595	KIT Puerta completa 10/11		-	1	-							
	1100002596	KIT Puerta completa 10/21		-	-	1							
1	R670608	Tapa cierre lampara		2	2	2							
	Q032021	Tornillo alomado M-4x10		8	8	8							
	Q222041	Remache exagonal M-4		8	8	8							
2	R670609	Junta cierre lampara		2	2	2							
3	R670618	Cristal de lampara		2	2	2							
4	R670610	Deflector de lampara		2	2	2							
5	R663013	Lampara 10 W. 12 V.		2	2	2							
6	R663058	Portalamparas		2	2	2							
7	R670611	Suplemento deflector		2	2	2							
	Q042031	Tornillo avellanado M-5x10		4	4	4							
8	R670617	Tope cristal interior		6	6	6							
9	R670615	Base de bisagra		2	2	2							
	Q042032	Tornillo avellanado M-5x15		2	2	2							
	Q222011	Remache exagonal M-5		2	2	2							
10	T080500	Contrapuerta completa 6/11		1	-	-							
10	T110500	Contrapuerta completa 10/11		-	1	-							
10	T120500	Contrapuerta completa 10/21		-	-	1							
11	3715200	Junta cristal L=1700		1	-	-							
11	3715200	Junta cristal L=2000		-	1	-							
11	3715200	Junta cristal L=2300		-	-	1							
12	Q212051	Tuerca sombrerete M-8		3	3	3							
13	Q242050	Arandela abanico A-8		3	3	3							
14	Q302025	Arandela plana Ø8,4xØ20x1,5		3	3	3							
15	Q012042	Tornillo exagonal M-6x15		1	1	1							
16	Q242040	Arandela abanico A-6		1	1	1							

MOD.		HORNOS A GAS HCG		ZONA	PUERTA						PLANO	C-1340	
ITEM	CODIGO	DENOMINACION	TEXTO	HCG-6/11	HCG-10/11	HCG-10/21	HCG-2-10/11						NOTAS
17	R662807	Arandela amarre puerta		1	1	1							
18	T130500	Bisagra superior		1	1	1							
19	R660534	Eje superior		1	1	1							
20	Z850519	Resorte		1	1	1							
21	R670612	Base de pestillo		2	2	2							
	Q302022	Arandela plana Ø16xØ6x1,2		2	2	2							
	Q242040	Arandela abanico A-6		2	2	2							
	Q162040	Tuerca exagonal M-6		2	2	2							
22	R660605	Muelle tensor pestillo		2	2	2							
23	R670613	Pestillo sujecion cristal interior		2	2	2							
24	R660600	Panel puerta 6/11		1	-	-							
24	R670600	Panel puerta 10/11		-	1	-							
24	R680600	Panel puerta 10/21		-	-	1							
	Q412002	Remache tubular Ø4x7,5		14	14	14							
25	R660606	Cristal exterior 6/11		1	-	-							
25	R670625	Cristal exterior 10/11		-	1	-							
25	R680609	Cristal exterior 10/21		-	-	1							
26	R660549	Guia eje inferior		1	1	1							
27	Q062040	Tornillo avellanado M-6x16		4	4	4							
28	R660551	Bisagra inferior		1	1	1							
29	Q242040	Arandela abanico A-6		2	2	2							
30	Q012041	Tornillo exagonal M-6x10		2	2	2							
31	T130502	Manilla		1	1	1							
32	Q132042	Varilla roscada M-6x15		1	1	1							
33	T130507	Piton enganche		2	2	2							
34	T130506	Resorte		2	2	2							
35	T130515	Guia manilla		1	1	1							
36	T130513	Soporte iman		1	1	1							
37	Z200507	Protector iman		1	1	1							

MOD.		HORNOS A GAS HCG		ZONA	PUERTA					PLANO	C-1340		
ITEM	CODIGO	DENOMINACION	TEXTO	HCG-6/11	HCG-10/11	HCG-10/21	HCG-2-10/11						NOTAS
38	Z200506	Iman		1	1	1							
39	Z100522	Interruptor magnetico		1	1	1							
40	T130514	Soporte resortes		1	1	1							
41	Q032032	Tornillo alomado M-5x15		2	2	2							
42	T130511	Suplemento fijacion cerradura		1	1	1							
43	Z608410	Casquillo		2	2	2							
44	Q352001	Pasador de aletas Ø2x15		4	4	4							
45	Q042043	Tornillo avellanado M-6x20		4	4	4							
46	R260545	Enganche		2	2	2							
47	R660538	Calzo de enganche		4	4	4							
48	Q221343	Remache exagonal M-6		4	4	4							
49	T080503	Suplemento elemento cierre		6	6	6							
50	T080504	Elemento de cierre		2	2	2							
51	Q262040	Arandela muelle A-6		8	8	8							
52	Q162040	Tuerca exagonal M-6		8	8	8							
53	R020502	Tubo alargadera		-	2	2							
54	T130509	Mecanismo de cierre		1	1	1							
55	Q262040	Arandela muelle A-6		2	2	2							
56	Q162040	Tuerca exagonal M-6		2	2	2							
57	T130508	Eje de manilla		1	1	1							
58	T130505	Casquillo		1	1	1							
59	Q271033	Arandela de seguridad Ø6		1	1	1							
60	Q032031	Tornillo alomado M-5x10		2	2	2							
60	Q032021	Tornillo alomado M-4x10		2	2	2							
61	T080502	Tapa cierre puerta		1	-	-							
61	T110502	Tapa cierre puerta		-	1	1							
62	1100002806	KIT Cristal interior completo 6/11		1	-	-							
62	1100002807	KIT Cristal interior completo 10/11		-	1	-							
62	1100002808	KIT Cristal interior completo 10/21		-	-	1							

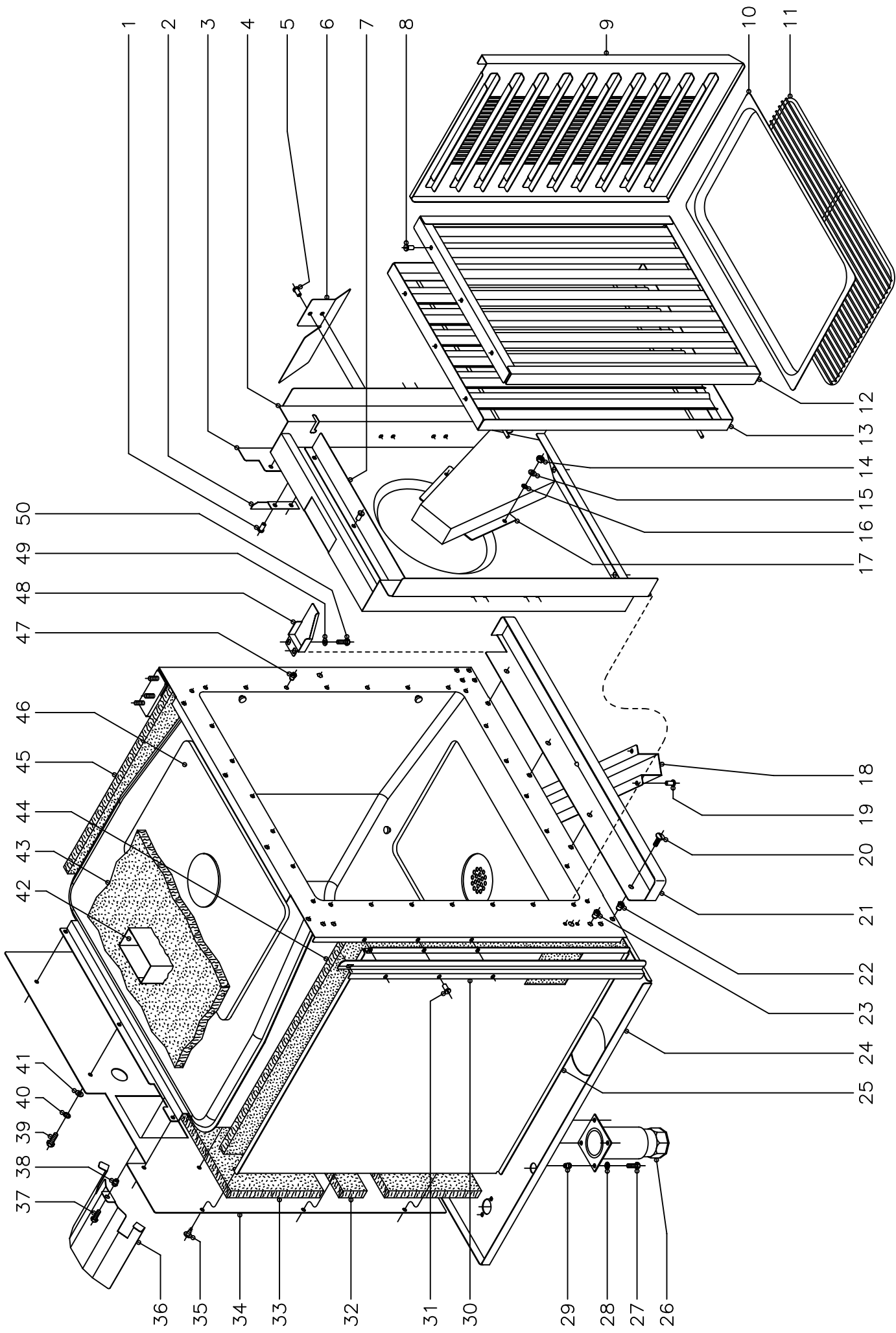



N plano C-1341	Firma 	Fecha 5-2003	Aparato HORNOS A GAS HCG-6/11,10/11,10/21	MUEBLE INTERIOR	Lamina 3	Fagor Industrial S.Coop. FAGOR Oñate
-------------------	-----------	-----------------	--	-----------------	-------------	--

MOD.		HORNOS A GAS HCG		ZONA	MUEBLE INTERIOR				PLANO	C-1341	
ITEM	CODIGO	DENOMINACION	TEXTO	HCG-6/11	HCG-10/11	HCG-10/21	HCG-2-10/11				NOTAS
1	Q412002	Remache tubular Ø 4x7,5		4	4	4	4				
2	R292647	Escuadra sujecion cubreventilador		2	2	2	2				
3	R662648	Aleron derecho		1	-	-	-				
s/n	R662647	Aleron izquierdo		1	-	-	-				
4	T082602	Cubre ventilador		1	-	-	-				
4	T012602	Cubre ventilador		-	1	-	-				
4	T022605	Cubre ventilador		-	-	1	1				
5	Q412002	Remache tubular Ø 4x7,5		-	8	8	8				
6	T012611	Aleron cubreventilador		-	4	4	4				
7	T012612	Separador		1	1	1	1				
	Q412002	Remache tubular Ø 4x7,5		3	3	3	3				
8	Q412002	Remache tubular Ø 4x7,5		6	6	6	6				
9	R662668	Guia de bandejas derecha		1	-	-	-				
s/n	R662670	Guia de bandejas izquierda		1	-	-	-				
9	T112615	Guia de bandejas derecha		-	1	-	-				
s/n	T112617	Guia de bandejas izquierda		-	1	-	-				
9	T122614	Guia de bandejas derecha		-	-	1	-				
s/n	T122616	Guia de bandejas izquierda		-	-	1	-				
10	R252816	Bandeja 1/1 (530x325x20)		1	1	-	1				
10	R032605	Bandeja 2/1 (530x650x40)		-	-	1	-				
11	R672665	Parrilla 1/1		1	1	-	1				
11	R682676	Parrilla 2/1		-	-	1	-				
12	R662617	Anterior de filtro		1	-	-	-				
12	R092618	Anterior de filtro		-	1	1	1				
13	R662622	Posterior de filtro		1	-	-	-				
13	R092621	Posterior de filtro		-	1	1	1				
14	Q162030	Tuerca exagonal M-5		2	2	2	2				
15	Q242030	Arandela abanico A-5		2	2	2	2				
16	Q232030	Arandela plana A-5		2	2	2	2				

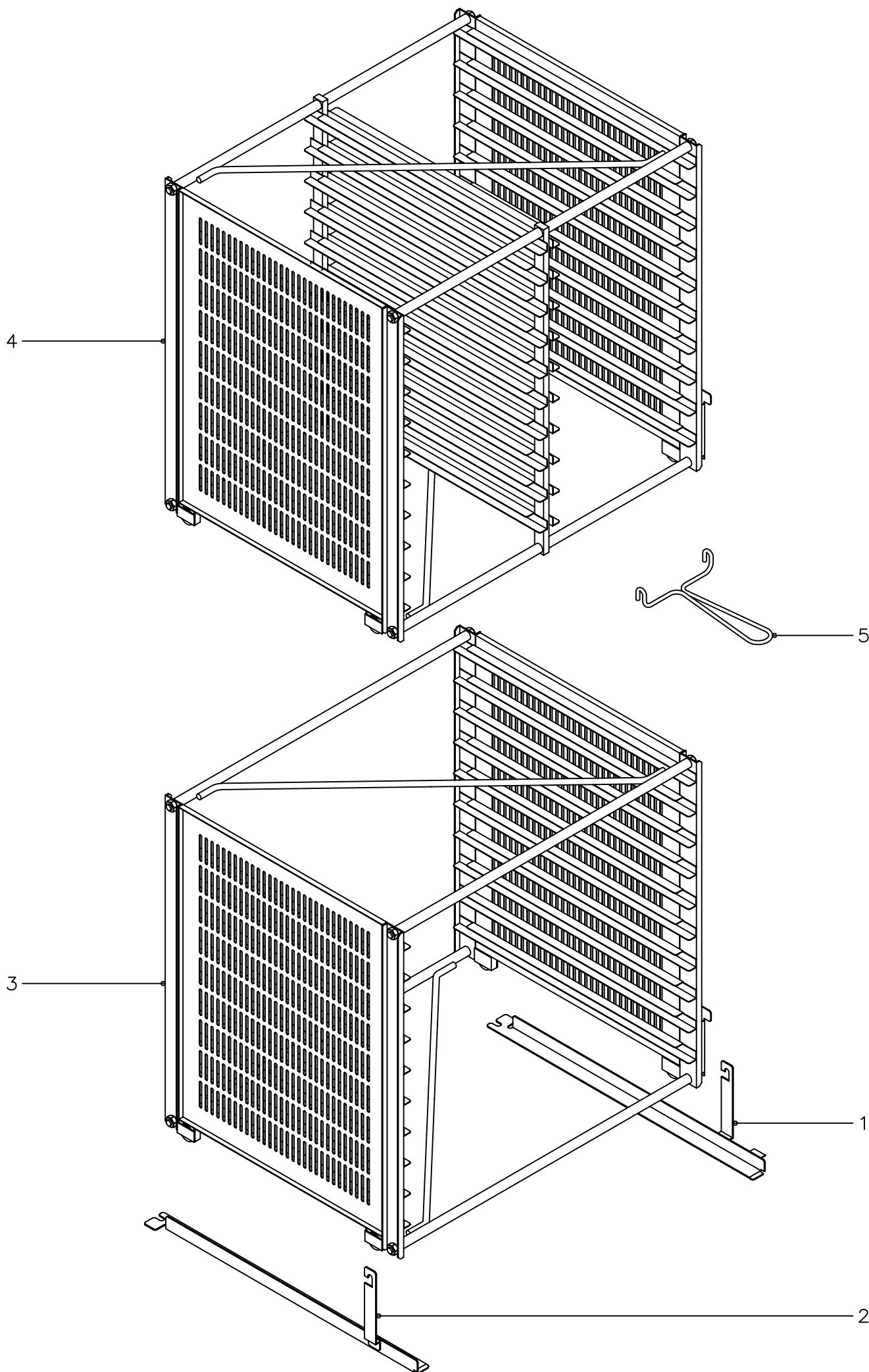

MOD.		HORNOS A GAS HCG		ZONA	MUEBLE INTERIOR				PLANO	C-1341	
ITEM	CODIGO	DENOMINACION	TEXTO	HCG-6/11	HCG-10/11	HCG-10/21	HCG-2-10/11				NOTAS
17	T082604	Conduccion de humos		1	-	-	-				
17	T012607	Conduccion de humos		-	1	1	1				
18	R672804	Cubre desagüe		1	1	-	-				
18	R682805	Cubre desagüe		-	-	1	1				
19	Q412002	Remache tubular Ø 4x7,5		8	8	8	8				
20	Q152017	Tornillo amarre M-6x13		4	4	4	4				
21	T112813	Recoge aguas		1	1	-	-				
21	T122811	Recoge aguas		-	-	1	1				
22	Q221343	Remache exagonal M-6		4	4	4	4				
23	Q221343	Remache exagonal M-6		8	8	8	8				
24	R722900	Base exterior de horno		1	1	-	-				
24	R732900	Base exterior de horno		-	-	1	1				
25	T072614	Soporte lateral aislante		1	-	-	-				
25	T112624	Soporte lateral aislante		-	1	-	-				
25	T122619	Soporte lateral aislante		-	-	1	1				
26	X260151	Pata regulable		4	4	4	4				
27	Q012031	Tornillo exagonal M-5x10		16	16	16	16				
28	Q242030	Arandela abanico A-5		16	16	16	16				
29	Q221342	Remache exagonal M-5		16	16	16	16				
30	R662682	Protector portamandos		1	-	-	-				
30	R672674	Protector portamandos		-	1	1	1				
31	Q412002	Remache tubular Ø 4x7,5		3	3	3	3				
32	R662616	Aislante posterior 560x60x20		4	4	4	4				
33	R672631	Aislante posterior 670x230x20		2	2	-	-				
33	R032625	Aislante posterior 760x230x20		-	-	2	2				
34	T072705	Soporte aislante posterior		1	-	-	-				
34	T112607	Soporte aislante posterior		-	1	-	-				
34	T122604	Soporte aislante posterior		-	-	1	1				
35	Q151301	Tornillo alomado		3	3	3	3				

MOD.		HORNOS A GAS HCG		ZONA	MUEBLE INTERIOR				PLANO	C-1341	
ITEM	CODIGO	DENOMINACION	TEXTO	HCG-6/11	HCG-10/11	HCG-10/21	HCG-2-10/11				NOTAS
36	R142628	Tejadillo motor turbina		1	1	1	1				
s/n	R142614	Tejadillo ventilador soplante		1	1	1	1				
37	Q012042	Tornillo exagonal M-6x15		4	4	4	4				
38	Q221343	Remache exagonal M-6		4	4	4	4				
39	Q012042	Tornillo exagonal M-6x15		12	12	12	12				
40	Q262040	Arandela muelle A-6		12	12	12	12				
41	Q232040	Arandela plana A-6		12	12	12	12				
42	T012605	Chimenea interior		1	1	1	1				
	Q412002	Remache tubular Ø 4x7,5		6	6	6	6				
43	R662614	Aislante base y techo 650x650x20		5	5	-	-				
43	R682623	Aislante base y techo 870x790x20		-	-	5	5				
44	R662613	Aislante lateral 650x530x20		3	-	-	-				
44	R672630	Aislante lateral 770x650x20		-	3	-	-				
44	R682623	Aislante lateral 860x790x20		-	-	3	3				
45	R662613	Aislante lateral 650x530x20		2	-	-	-				
45	R672630	Aislante lateral 770x650x20		-	2	-	-				
45	R682623	Aislante lateral 860x790x20		-	-	2	2				
46	T082610	Cuerpo interior horno		1	-	-	-				
46	T012615	Cuerpo interior horno		-	1	-	-				
46	T022608	Cuerpo interior horno		-	-	1	1				
47	Q221341	Remache exagonal M-4		24	28	28	28				
48	R662800	Cubre cables		1	1	1	1				
49	Q232030	Arandela plana A-5		2	2	2	2				
50	Q012031	Tornillo exagonal M-5x10		2	2	2	2				

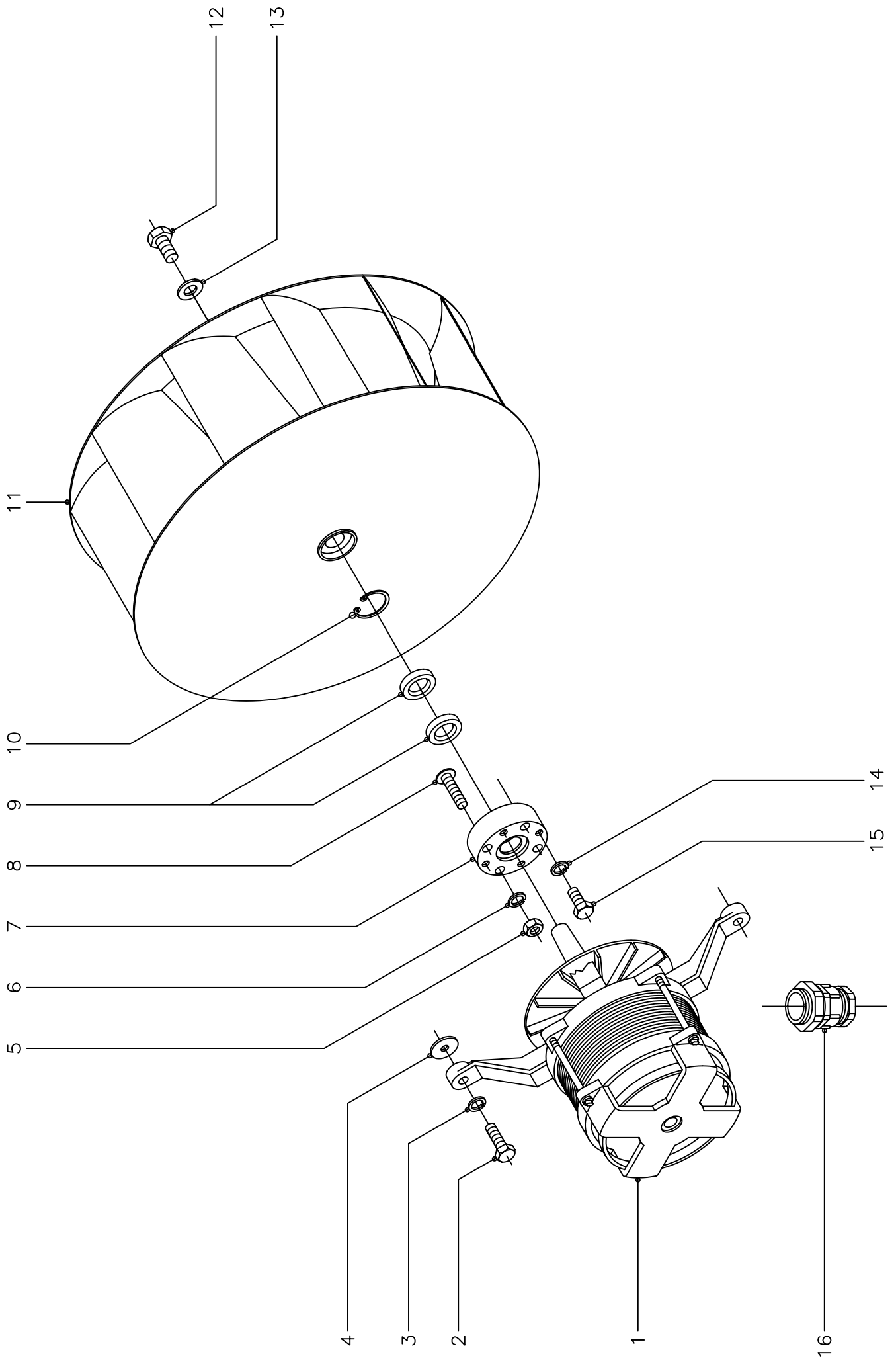

N plano C-1342	Firma 	Fecha 5-2003	Aparato EXTRUCTURAS PORTABANDEJAS HORNOS A GAS HCG-10/11,10/21	Lamina 4	Fagor Industrial S.Coop. FAGOR  Oñate
-------------------	--	-----------------	--	-------------	--



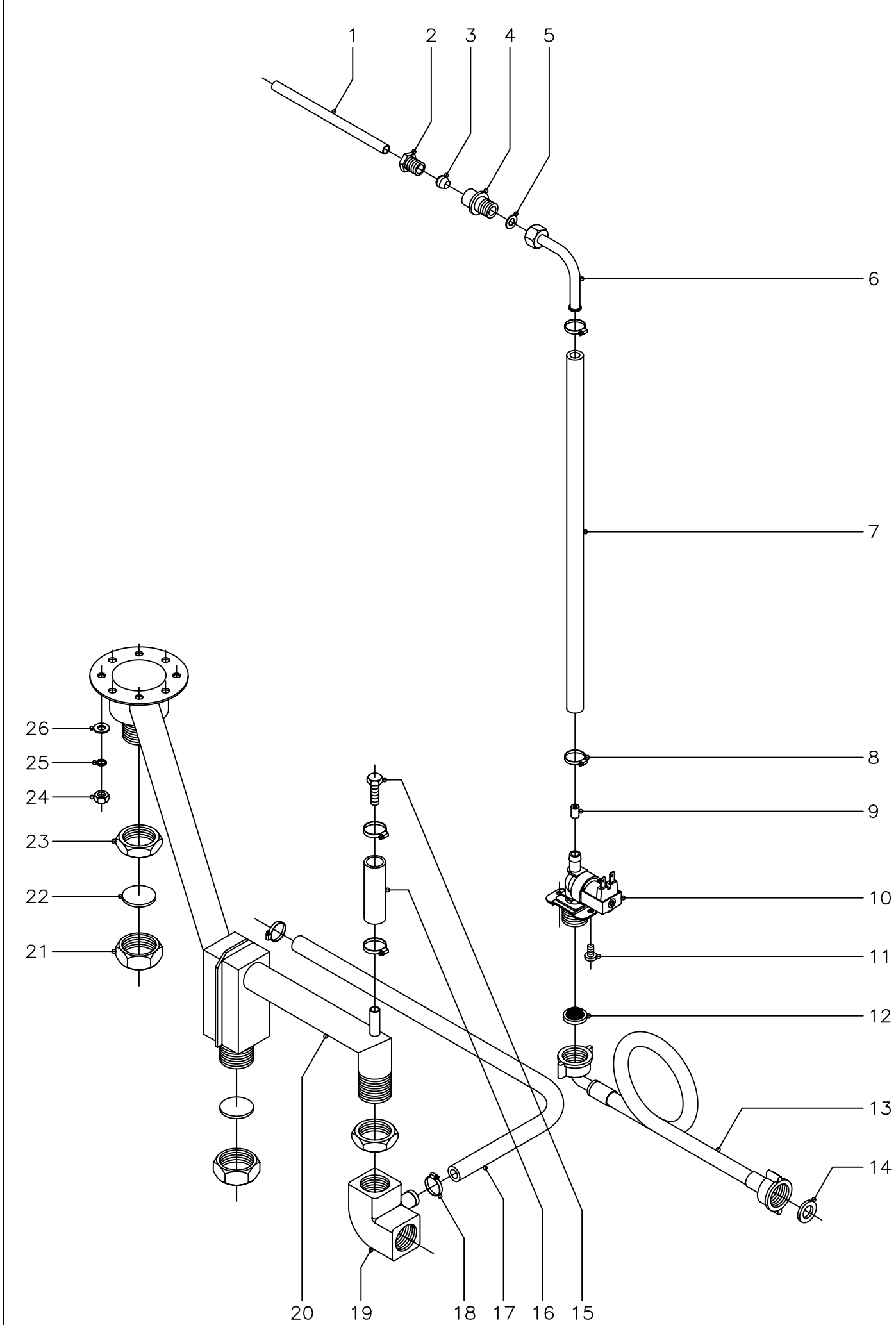

N plano C-1343	Firma 	Fecha 5-2003	Aparato TURBINA HORNOS A GAS HCG-6/11,10/11,10/21	Lamina 5	Fagor Industrial S.Coop. FAGOR  Onate
-------------------	--	-----------------	---	-------------	--

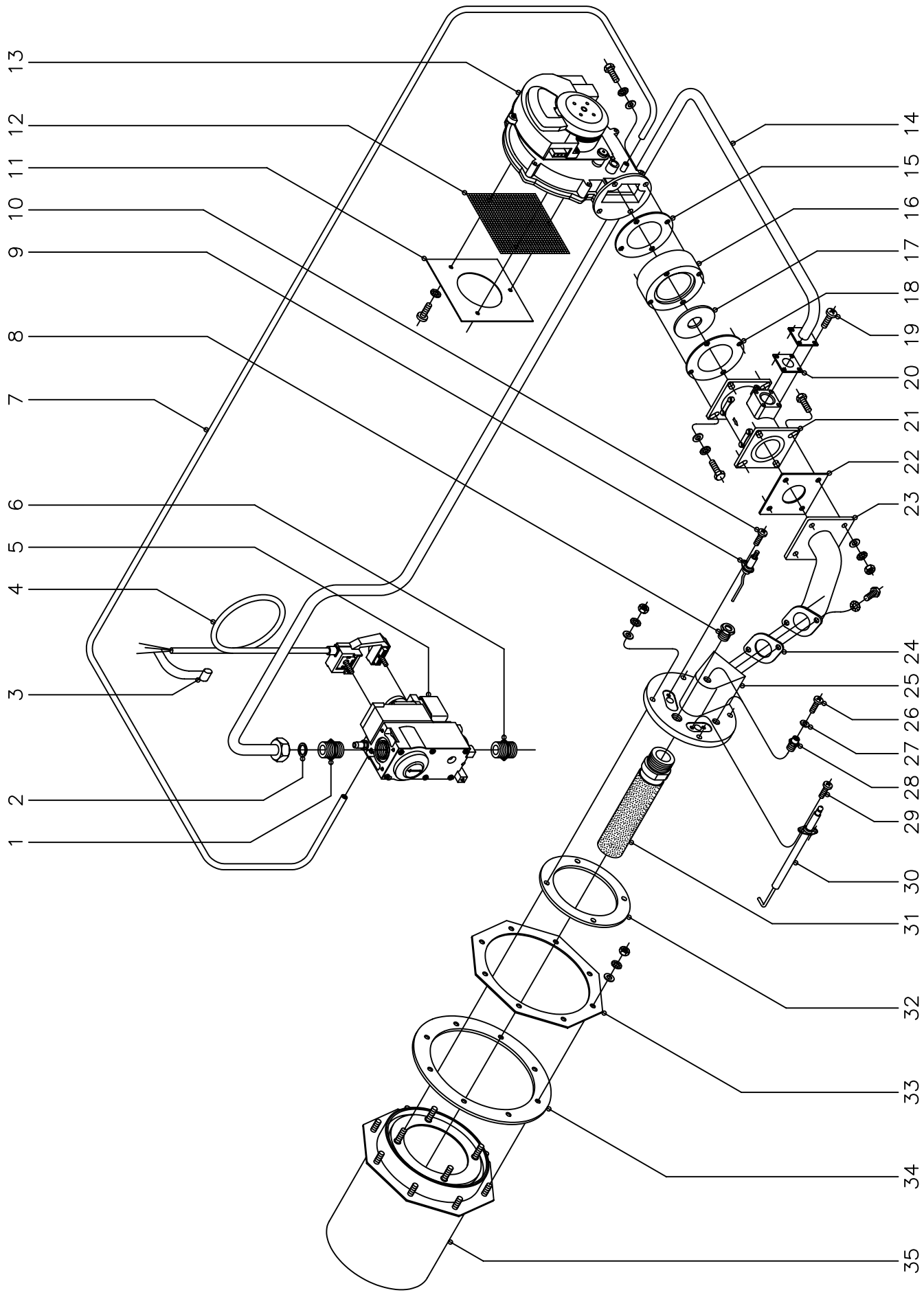

N plano C-1344	Firma 	Fecha 5-2003	Aparato HORNOS A GAS HCG-6/11,10/11,10/21	CIRCUITO DE AGUA	Lamina 6	Fagor Industrial S.Coop. FAGOR Onate
-------------------	-----------	-----------------	--	------------------	-------------	--

MOD.		HORNOS A GAS HCG		ZONA	CIRCUITO DE AGUA					PLANO	C-1344		
ITEM	CODIGO	DENOMINACION	TEXTO	HCG-6/11	HCG-10/11	HCG-10/21	HCG-2-10/11						NOTAS
1	R020502	Tubo alargadera		1	1	1							
2	R695003	Manguito cierre		1	1	1							
3	R695004	Bicono		1	1	1							
4	-	Casquillo soldado a cuerpo de horno		1	1	1							
5	Q306026	Arandela junta Ø 14xØ 8,5x1,5		1	1	1							
6	R695017	Tubo conduccion agua		1	1	1							
7	3676900	Tubo goma negra Ø17xØ10x1000		1	1	1							
8	Q881302	Abrazadera 12 - 20		6	6	6							
9	R665041	Regulador caudal 0,25l. (verde)		1	1	1							
10	Z701135	Electrovalvula entrada agua		1	1	1							
11	Q032021	Tornillo alomado M-4x10		2	2	2							
12	Z701132	Filtro-junta entrada de agua		1	1	1							
13	Z601114	Manguera entrada de agua		1	1	1							
14	Q307031	Junta manguera Ø24xØ14x3		1	1	1							
15	Q012053	Tornillo exagonal M-8x20		1	1	1							
16	3676900	Tubo goma negra Ø17xØ10x100		1	1	1							
17	3715600	Tubo silicona forrado Ø26xØ18x1000		1	1	1							
18	Q881304	Abrazadera 20 - 32		2	2	2							
19	R665067	Codo desagüe		1	1	1							
20	R725004	Tubo desagüe completo		1	1	-							
20	R735004	Tubo desagüe completo		-	-	1							
21	R665053	Tuerca tapon		2	2	2							
22	R015011	Arandela junta Ø 34x3		2	2	2							
23	Q223014	Contratuerca 1"		2	2	2							
24	Q162040	Tuerca exagonal M-6		8	8	8							
25	Q262040	Arandela muelle A-6		8	8	8							
26	Q232040	Arandela plana A-6		8	8	8							



N plano C-1345	Firma 	Fecha 5-2003	Aparato PARTE FUNCIONAL GAS HORNOS A GAS HCG-6/11,10/11,10/21	Lamina 7	Fagor Industrial S.Coop. FAGOR Ofite
-------------------	--	-----------------	---	-------------	--

MOD.		HORNOS A GAS HCG		ZONA	PARTE FUNCIONAL GAS						PLANO	C-1345	
ITEM	CODIGO	DENOMINACION	TEXTO	HCG-6/11	HCG-10/11	HCG-10/21	HCG-2-10/11						NOTAS
1	S205023	Manguito doble 1/2"		1	1	1							
2	Q306012	Arandela junta Ø18xØ13x1,5		1	1	1							
3	Z233012	Condensador antiparasitario		1	1	1							
4	T085012	Conector valvula Honeywell		1	1	1							
5	T085010	Valvula Honeywell (Regulado a B.P.)		1	-	-							(50 Hz.)
5	T085011	Valvula Honeywell (Regulado a G.N.)		1	-	-							(50 Hz.)
5	T115097	Valvula Honeywell (Regulado a B.P.)		-	1	1							(50 Hz.)
5	T115098	Valvula Honeywell (Regulado a G.N.)		-	1	1							(50 Hz.)
5	T085016	Valvula Honeywell (Regulado a B.P.)		1	-	-							(60 Hz.)
5	T085017	Valvula Honeywell (Regulado a G.N.)		1	-	-							(60 Hz.)
5	T115100	Valvula Honeywell (Regulado a B.P.)		-	1	1							(60 Hz.)
5	T115101	Valvula Honeywell (Regulado a G.N.)		-	1	1							(60 Hz.)
6	S205023	Manguito doble 1/2"		1	1	1							
7	3702400	Tube goma negra Ø 8xØ 4x1500		1	1	1							
8	R725015	Visor de encendido		1	1	1							
9	T115712	Electrodo de deteccion		1	1	1							
10	Q153021	Tornillo alomado M-4x10		1	1	1							
11	T115096	Chapa amarre malla ventilador		1	1	1							
	Q032021	Tornillo alomado M-4x10		3	3	3							
	Q242020	Arandela abanico A-4		3	3	3							
12	T115095	Malla ventilador		1	1	1							
13	T083000	Ventilador E.B.M.-RG130		1	1	1							
14	T015000	Conduccion de gas completo		1	1	-							
14	T025000	Conduccion de gas completo		-	-	1							
15	T115081	Junta acoplamiento ventilador y mixer		1	1	1							
16	T115076	Acoplamiento ventilador mixer		1	1	1							
17	T085018	Arandela regulacion ventilador Ø14		1	-	-							(But. Pro. Y Gas Natural)
17	T115082	Arandela regulacion ventilador Ø18		-	1	1							(Butano-Propano
17	T115083	Arandela regulacion ventilador Ø20		-	1	1							(Gas Natural)

MOD.		HORNOS A GAS HCG		ZONA	PARTE FUNCIONAL GAS						PLANO	C-1345	
ITEM	CODIGO	DENOMINACION	TEXTO	HCG-6/11	HCG-10/11	HCG-10/21	HCG-2-10/11						NOTAS
18	T115081	Junta acoplamiento ventilador y mixer		1	1	1							
19	Q032021	Tornillo alomado M-4x10		4	4	4							
20	T115080	Junta conduccion mixer		1	1	1							
21	T085007	Mixer 25 KW.		1	-	-							
21	T115075	Mixer 35 KW.		-	1	1							
22	T115079	Junta mixer conducto		1	1	1							
23	T115077	Conducto mixer tapa principal		1	1	1							
24	T095021	Junta conducto tapa		1	1	1							
25	T085715	Tapa principal		1	-	-							
25	T115782	Tapa principal		-	1	1							
26	Q152024	Tornillo avellanado M-4x8		2	2	2							
27	R725061	Junta toma de presion		2	2	2							
28	R725017	Boquilla toma de presion		2	2	2							
29	Q153021	Tornillo alomado M-4x10		1	1	1							
30	T085714	Electrodo de ignicion		1	-	-							
30	T115781	Electrodo de ignicion		-	1	1							
31	T085710	Quemador Furigas (6/11)		1	-	-							
31	T115710	Quemador Furigas (10/11 y 10/21)		-	1	1							
32	T075013	Junta de tapa principal		1	-	-							
32	R725055	Junta de tapa principal		-	1	1							
33	-	Brida amarre camara combustion		-	-	-							Caldeado a cuerpo de horno
34	T075014	Junta camara combustion		1	-	-							
34	R725051	Junta camara combustion		-	1	1							
35	T085713	Camara de combustion		1	-	-							
35	T015700	Camara de combustion		-	1	1							
	Q232040	Arandela plana A-6		8	8	8							
	Q262040	Arandela muelle A-6		8	8	8							
	Q163040	Tuerca exagonal M-6 (laton)		8	8	8							

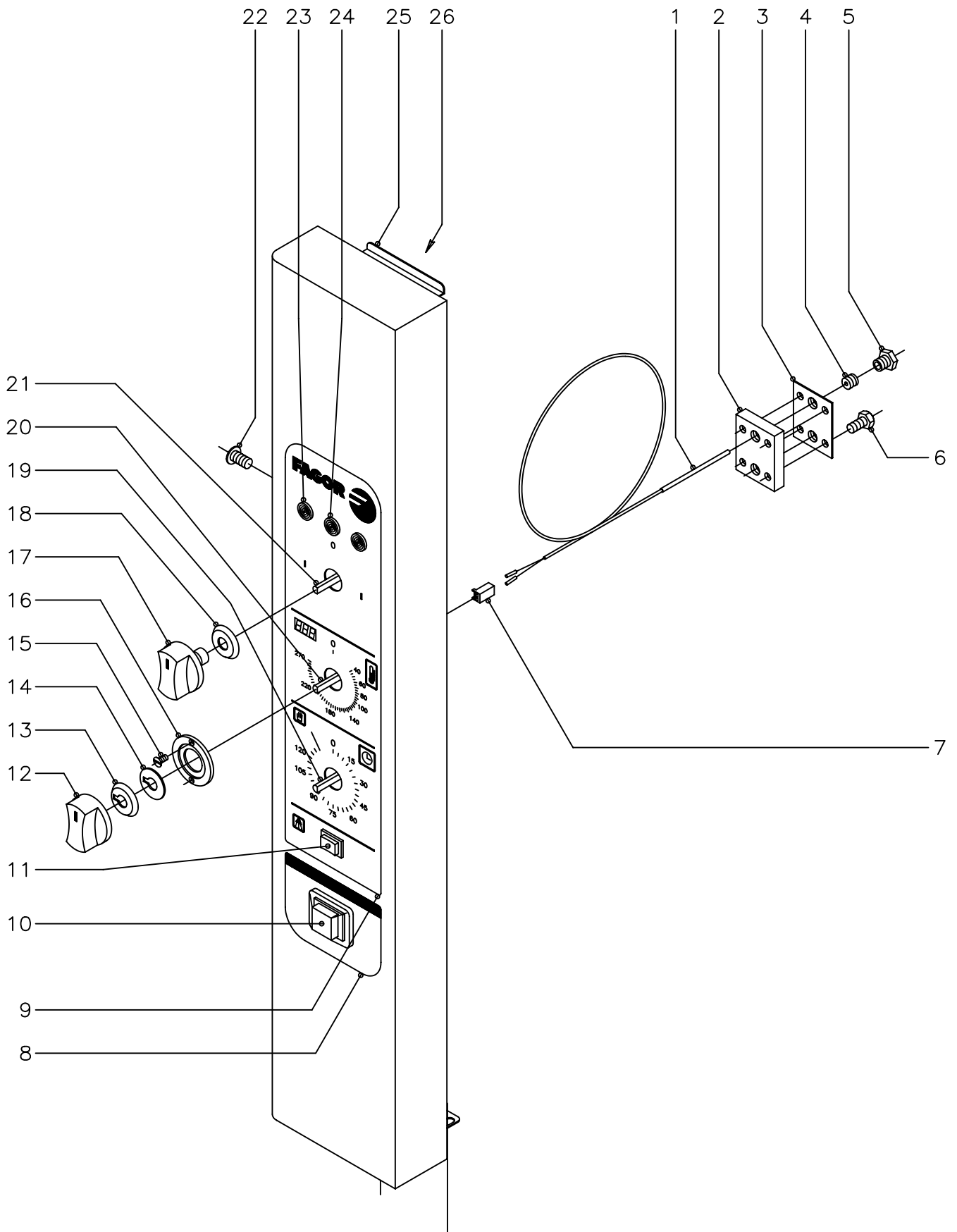

N plano C-1346	Firma <i>[Signature]</i>	Fecha 5-2003	Aparato HORNO A GAS HCG-6/11,10/11,10/21	PARTE ELECTRICA PORTAMANDOS	Lamina 8	Fagor Industrial S.Coop. FAGOR Oñate
-------------------	-----------------------------	-----------------	---	-----------------------------	-------------	--

MOD.		HORNOS A GAS HCG		ZONA	PARTE ELECTRICA PORTAMANDOS						PLANO	C-1346	
ITEM	CODIGO	DENOMINACION	TEXTO	HCG-6/11	HCG-10/11	HCG-10/21	HCG-2-10/11						NOTAS
1	R663090	Conjunto termopar L=1400		1	1	1							
2	R662659	Pasamuros doble		1	1	1							
3	R692811	Junta pasamuros doble		1	1	1							
4	R662652	Bicono cierre sonda		1	1	1							
5	R662629	Racord cierre sonda		1	1	1							
6	Q012021	Tornillo exagonal M-4x10		4	4	4							
7	R663092	Conector 2 vias		1	1	1							
8	R723008	Serigrafia inferior		1	1	1							
9	T013006	Serigrafia superior		1	1	1							
10	Z213033	Pulsador de rearme		1	1	1							
11	R663032	Pulsador		1	1	1							
12	R663063	Boton de mando Ø6 (termos.elec.)		1	1	1							
13	R663045	Junta (termostato electronico)		1	1	1							
14	R662810	Arandela guia		1	1	1							
15	Q151346	Tornillo avellanado M-3x5		2	2	2							
16	R662809	Guia boton de mando		1	1	1							
17	R663062	Boton de mando Ø6 (conmutadores)		2	2	2							
18	R663046	Junta (conmutadores)		2	2	2							
19	R723000	Temporizador manual		1	1	1							
20	R743013	Termostato electronico 0 - 270° C.		1	1	1							
	R663036	Fijacion circuito termost. electroni.		4	4	4							
21	T013001	Conmutador de funciones		1	1	1							
22	Q152004	Tornillo aplastado M-5x13		2	2	2							
23	R693056	Piloto ambar		2	2	2							
24	R693055	Piloto verde		1	1	1							
25	T082810	Panel portamandos		1	-	-							
25	T012809	Panel portamandos		-	1	1							
26	T012803	Soporte componentes		1	1	1							

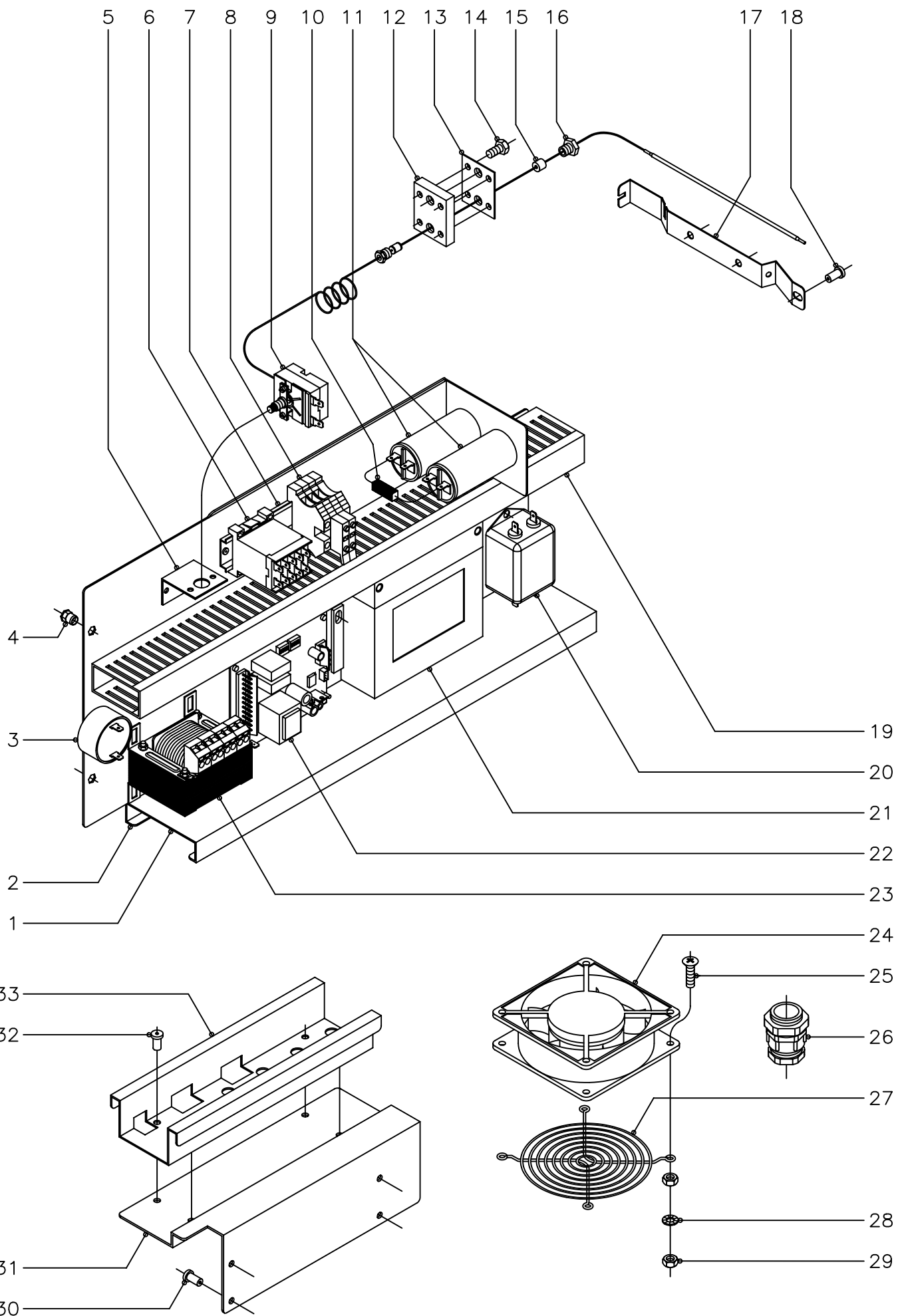

N plano
C-1347

Firma
[Signature]

Fecha
5-2003

Aparato
HORNOS A GAS HCG-6/11,10/11,10/21

PANEL CUADRO ELECTRICO

Lamina
9

Fagor Industrial S.Coop. **FAGOR**
Onate

MOD.		HORNOS A GAS HCG		ZONA	PANEL CUADRO ELECTRICO						PLANO	C-1347	
ITEM	CODIGO	DENOMINACION	TEXTO	HCG-6/11	HCG-10/11	HCG-10/21	HCG-2-10/11						NOTAS
1	T083003	Panel cuadro electrico		1	1	1							
2	R723101	Contra guia panel cuadro electrico		1	1	1							
	Q412002	Remache tubular Ø 4x7,5		8	8	8							
3	R693067	Zumbador		1	1	1							
4	Q221342	Remache exagonal M-5		2	2	2							
5	R343039	Soporte termostato		1	1	1							
6	Z683087	Contactador		1	1	1							
7	R663055	Guia contactor L=120		1	1	1							
8	R073005	Borna portafusible		2	2	2							
	R723015	Fusible cristal 10 A.		2	2	2							
	P453026	Borne tierra 10		1	1	1							
	Z263303	Tope final		1	1	1							
9	R243016	Termostato limitador		1	1	1							
	Q162050	Tuerca exagonal M-8x1		1	1	1							
10	R073008	Cableado PTC		1	1	1							
11	R293000	Condensador		2	2	2							
12	R662659	Pasamuros doble		1	1	1							
13	R692811	Junta pasamuros doble		1	1	1							
14	Q012021	Tornillo exagonal M-4x10		4	4	4							
15	R662662	Junta cierre bulbo limitador		1	1	1							
16	R662629	Racord cierre sonda		1	1	1							
17	R662630	Soporte bulbo		1	1	1							
18	Q412002	Remache tubular Ø 4x7,5		3	3	3							
19	3715520	Canaleta unex (60x30xlonjitud)		4	4	4							
20	T113023	Filtro de entrada modelo FF-6Z		1	1	1							
21	Z953004	Control combustion		1	1	1							
22	T083002	Variador de velocidad		1	1	1							
	T133007	Distanciador M-3		4	4	4							Amarre variador a cuadro
	T133008	Tornillo amarre M-3x23 (plastico)		4	4	4							Amarre variador a cuadro

MOD.		HORNOS A GAS HCG		ZONA	PIEZAS ESPECIFICAS PARA LOS DISTINTOS GASES (B.P. Y G.N.) Y DISTINTAS FRECUENCIAS (50 Y 60 Hz.)						PLANO	C-1345		
ITEM	CODIGO	DENOMINACION	TEXTO	HCG-6/11	HCG-10/11	HCG-10/21	HCG-2-10/11	HCG-6/11A	HCG-10/11A	HCG-10/21A	HCG-2-10/11A			NOTAS
		<u>BUTANO - PROPANO 50 Hz.</u>												
5	T085010	Valvula Honeywell 50Hz. (B.P.)		1	-	-		1	-	-				
5	T115097	Valvula Honeywell 50Hz. (B.P.)		-	1	1		-	1	1				
17	T085013	Arandela regulacion ventilador Ø14		1	-	-		1	-	-				
17	T115082	Arandela regulacion ventilador Ø18		-	1	1		-	1	1				
		<u>BUTANO - PROPANO 60 Hz.</u>												
5	T085016	Valvula Honeywell 60Hz. (B.P.)		1	-	-		1	-	-				
5	T115100	Valvula Honeywell 60Hz. (B.P.)		-	1	1		-	1	1				
17	T085013	Arandela regulacion ventilador Ø14		1	-	-		1	-	-				
17	T115082	Arandela regulacion ventilador Ø18		-	1	1		-	1	1				
		<u>GAS NATURAL 50 Hz.</u>												
5	T085011	Valvula Honeywell 50Hz. (G.N.)		1	-	-		1	-	-				
5	T115098	Valvula Honeywell 50Hz. (G.N.)		-	1	1		-	1	1				
17	T085013	Arandela regulacion ventilador Ø14		1	-	-		1	-	-				
17	T115083	Arandela regulacion ventilador Ø20		-	1	1		-	1	1				
		<u>GAS NATURAL 60 Hz.</u>												
5	T085017	Valvula Honeywell 60Hz. (G.N.)		1	-	-		1	-	-				
5	T115101	Valvula Honeywell 60Hz. (G.N.)		-	1	1		-	1	1				
17	T085013	Arandela regulacion ventilador Ø14		1	-	-		1	-	-				
17	T115083	Arandela regulacion ventilador Ø20		-	1	1		-	1	1				

HCG-6/11 HCG-10/11 HCG-10/21 HCG-20/11 HCG-20/21

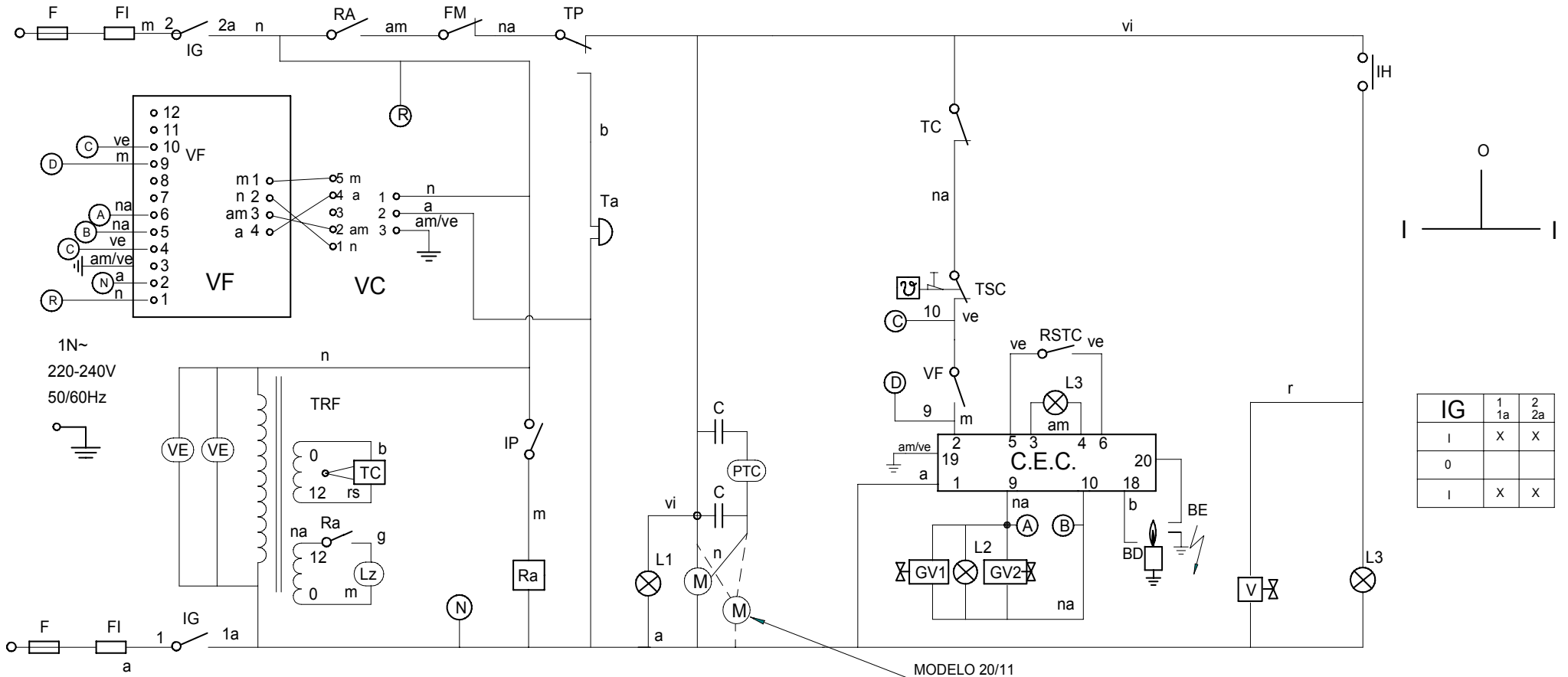

ESQUEMA TEORICO ADHESIVO			T-013044	
Nº	Pieza	Material	Nº Clasificacion	Acabado
Nº	Modificacion	Propuesta de	Fecha	Tolerancias generales
				<5±
				5-25±
				25-50±
				50-100±
				> 100±
				∞±
Dibujado	Firma	Fecha	 Fagor Industrial, Koop. Elk. Mugatua	
Proyectado	KONTXI	5/6/01		
Comprobado				
Escala	<h2>HORNOS HCG</h2>			Plano numero
				HC-75723
	Plano hau ez dateke erabil ez berrizta gure baimenitz gabe			Sustituye al N°
				Sustituido por

ESPAÑOL

FRANÇAIS

ENGLISH

DEUTSCH

ITALIANO

CODIGO DE COLORES:

r = rojo
a = azul
m = marron
g = gris
n = negro
b = blanco
vi = violeta
am = amarillo
na = naranja
rs = rosa
ve = verde
am/ve = amarillo verde

COMPONENTES:

BD = Bujía de detector de llama
BE = Bujía de Encendido
C = Condensador Motor
C.E.C. = Control Encendido cámara
C.E.V. = Control encendido vapor
CN = Control nivel de agua
① F, F1, F2, F3 = Fusible
FI = Filtro interferencias
FM = Térmico Motor
GV1 = Electroválvula de gas cámara (Control)
GV2 = Electroválvula de gas cámara (Seguridad)
GV4 = Electroválvula de gas vapor (Control)
GV5 = Electroválvula de gas vapor (Seguridad)
la = Micro chimenea abierta
lc = Micro chimenea cerrada
IG = Interruptor general
IP = Interruptor puerta
IR = Selector regulador sonda núcleo
L1 = Lámpara de funcionamiento
L2 = Lámpara calentamiento cámara
L4 = Lámpara entrada de vapor
L3 = Lámpara indicador de bloqueo cámara
L5 = Lámpara indicador de bloqueo vapor
L6 = Lámpara seguridad de vapor
L7 = Lámpara detección de cal
Lz = Luz interior cámara
M = Motor
M1 = Motor accionamiento chimenea
R2, R1, Ra = Relé Auxiliar
RE1 = Regulador de energía
RSTC = Pulsador de rearme cámara
RSTV = Pulsador de rearme vapor
RTS = Regulador sonda núcleo
T100 = Termostato fijo 100°C
Ta = Timbre avisador
TC = Termostato cámara
TCN = Termostato condensación
TDC = Termostato detección de cal
① TP, TMP = Temporizador
① TRF, TRF1 = Transformador
TSC = Termostato seguridad cámara
TSV = Termostato seguridad de vapor
TV = Termostato de vapor
V1 = Electroválvula de agua de llenado
VC = Ventilador centrifugo premezcla
VCN = Electroválvula de agua de condensación
VE = Ventilador cuadro eléctrico
VF = Variador de frecuencia

CODES DE COULEURS:

r = rouge
a = bleu
m = marron
g = gris
n = noir
b = blanc
vi = violet
am = jaune
na = orange
rs = rose
ve = vert
am/ve = jaune/vert

COMPOSANTS:

BD = Veilleuse de détection de flamme
BE = Veilleuse d'allumage
C = Condensateur moteur
C.E.C. = Contrôle d'allumage de chambre
C.E.V. = Contrôle d'allumage de vapeur
CN = Contrôle du niveau d'eau
① F, F1, F2, F3 = Fusible
FI = Filtre interférences
FM = Moteur thermique
GV1 = Electrovalve de chambre gaz (control)
GV2 = Electrovalve de chambre gaz (sécurité)
GV4 = Electrovalve de vapeur gaz (control)
GV5 = Electrovalve de vapeur gaz (sécurité)
la = Micro cheminée ouverte
lc = Micro cheminée fermée
IG = Interruptor general
IP = Interruptor de porte
IR = Sélecteur régulateur de sonde noyau
L1 = Lampe de fonctionnement
L2 = Lampe de chauffe chambre
L4 = Lampe d'arrivée de vapeur
L3 = Lampe témoin de blocage de chambre
L5 = Lampe témoin de blocage de vapeur
L6 = Lampe de sureté de vapeur
L7 = Lampe de détection de calcaire
Lz = LumiÈre intérieure de chambre
M = Moteur
M1 = Actionnement moteur de cheminée
R2, R1, Ra = Relais auxiliaire
RE1 = Régulateur d'énergie
RSTC = Bouton de réarmement de chambre
RSTV = Bouton de réarmement de vapeur
RTS = Régulateur de sonde noyau
T100 = Thermostat fixe 100°C
Ta = Sonnerie d'alarme
TC = Thermostat de chambre
TCN = Thermostat de condensation
TDC = Thermostat de détection de calcaire
① TP, TMP = Temporisateur 0-120
① TRF, TRF1 = Transformador
TSC = Thermostat de sureté de chambre
TSV = Thermostat de sureté de vapeur
TV = Thermostat de vapeur
V1 = Electrovalve de remplissage d'eau
VC = Ventilateur de centrifugeuse de prémélange
VCN = Electrovalve de condensation d'eau
VE = Ventilateur tableau électrique
VF = Variador de frecuencia

COLOUR CODE

r = red
a = blue
m = brown
g = grey
n = black
b = white
vi = violet
am = yellow
na = orange
rs = pink
ve = green
am/ve = yellow-green

COMPONENTS:

BD = Flame detector spark plug
BE = Ignition spark plug
C = Motor condenser
C.E.C. = Cooking chamber ignition control
C.E.V. = Steam ignition control
CN = Water level control
① F, F1, F2, F3 = Fusible
FI = Interference filter
FM = Motor thermal switch
Cooking chamber gas solenoid valve (control)
GV2 = Cooking chamber gas solenoid valve (safety)
GV4 = Steam gas solenoid valve (control)
GV5 = Steam gas solenoid valve (safety)
la = Chimney open microswitch
lc = Chimney closed microswitch
IG = Interruptor general
IP = Door switch
IR = Core probe regulator selector
L1 = On/off lamp
L2 = Cooking chamber heating lamp
L4 = Steam inlet lamp
L3 = Cooking chamber lock indicator lamp
L5 = Steam lock indicator lamp
L6 = Steam safety lamp
L7 = Lime detection lamp
Lz = Cooking chamber interior lamp
M = Motor
M1 = Chimney drive motor
R2, R1, Ra = Auxiliary relay
RE1 = Energy regulator
RSTC = Cooking chamber reset button
RSTV = Steam reset button
RTS = Core probe regulator
T100 = Fixed 100°C thermostat
Ta = Warning buzzer
TC = Cooking chamber thermostat
TCN = Condensation thermostat
TDC = Lime detection thermostat
① TP, TMP = 0-120 timer
① TRF, TRF1 = Transformer
TSC = Cooking chamber safety thermostat
TSV = Steam safety thermostat
TV = Steam thermostat
V1 = Water filling solenoid valve
VC = Pre-mix centrifuge fan
VCN = Condensation water solenoid valve
VE = Switchboard fan
VF = Frequency inverter

FARBENCODE

r = rot
a = blau
m = braun
g = grau
n = schwarz
b = weiss
vi = violett
am = gelb
na = orangers
rs = rosa
ve = grün
am/ve = gelb/grün

KOMPONENTEN:

BD = Zündkerze des Flammendetektors
BE = Zündkerze der Zündung
C = Motorkondensator
C.E.C. = Zündkontrolle Kammer
C.E.V. = Zündkontrolle Dampf
CN = Kontrolle Wasserstand
① F, F1, F2, F3 = Fusible
FI = Interferenzfilter
FM = Thermometer
GV1 = Electroventil Gas, Kammer (Kontrolle)
GV2 = Electroventil Gas, Kammer (Sicherheit)
GV4 = Electroventil Gas, Dampf (Kontrolle)
GV5 = Electroventil Gas, Dampf (Sicherheit)
la = Mikroschacht geöffnet
lc = Mikroschacht geschlossen
IG = Hauptschalter
IP = Turschalter
IR = Wahlregler Kernsonde
L1 = Funktionsleuchtanzeige
L2 = Erwärmungsleuchtanzeige Kammer
L4 = Leuchtanzeige Dampftritt
L3 = Leuchtanzeige Blockierung Kammer
L5 = Leuchtanzeige Blockierung Dampf
L6 = Sicherheitsleuchtanzeige Dampf
L7 = Kalkanzeige
Lz = Innenbeleuchtung Kammer
M = Motor
M1 = Motorantrieb Mikroschacht
R2, R1, Ra = Relé Auxiliar
RE1 = Hilfsrelais
RSTC = Bedienungstaste Durch, Aufladung Kammer
RSTV = Bedienungstaste Durch, Aufladung Dampf
RTS = Kernsondenregler
T100 = Thermostat auf 100°C
Ta = Meldeklöngel/Lautwerk
TC = Thermostat Kammer
TCN = Kondensationsthermostat
TDC = Thermostat Kalkanzeige
① TP, TMP = Zeitschalter 0-120
① TRF, TRF1 = Transformator
TSC = Sicherheitsthermostat Kammer
TSV = Sicherheitsthermostat Dampf
TV = Dampfthermostat
V1 = Elektroventil Wasserfüllung
VC = Zentrifugallüfter Vormischung
VCN = Elektroventil Kondenswasser
VE = Schalttafelventilator
VF = Frequenzwandler

CODICE DEI COLORI:

r = rosso
a = azzurro
m = marrone
g = grigio
n = nero
b = bianco
vi = viola
am = giallo
na = arancione
rs = rosa
ve = verde
am/ve = giallo/verde

COMPONENTI:

BD = Candela del rilevatore di fiamma
BE = Candela d'accensione
C = Condensatore motore
C.E.C. = Controllo accensione cabina
C.E.V. = Controllo accensione vapore
CN = Controllo livello d'acqua
① F, F1, F2, F3 = Fusibile
FI = Filtro interferenze
FM = Termico Motore
GV1 = Elettrovalvola gas cabina (controllo)
GV2 = Elettrovalvola gas cabina (sicurezza)
GV4 = Elettrovalvola gas vapore (controllo)
GV5 = Elettrovalvola gas vapore (sicurezza)
la = Micro camino aperto
lc = Micro camino chiuso
IG = Interruttore generale
IP = Interruttore porta
IR = Selettore regolatore sonda nucleo
L1 = Lampadina di funzionamento
L2 = Lampadina riscaldamento cabina
L4 = Lampadina ingresso vapore
L3 = Lampadina indicatore di blocco cabina
L5 = Lampadina indicatore di blocco vapore
L6 = Lampadina di sicurezza vapore
L7 = Lampadina rilevatore di calcare
Lz = Luce interna cabina
M = Motore
M1 = Motore funzionamento camino
R2, R1, Ra = Relais ausiliario
RE1 = Regolatore d'energia
RSTC = Pulsante di riarmo vapore
RSTV = Regolatore sonda nucleo
RTS = Regolador Sonda Nucleo
T100 = Termostato fisso 100°C
Ta = Campanello avvisatore
TC = Termostato cabina
TCN = Termostato condensazione
TDC = Termostato rilevatore di calcare
① TP, TMP = Timer 0-120
① TRF, TRF1 = Transformador
TSC = Termostato sicurezza cabina
TSV = Termostato sicurezza vaspore
TV = Termostato vapore
V1 = Elettrovalvola acqua di riempimento
VC = Ventilatore centrifuga
VCN = Elettrovalvola acqua di condensazione
VE = Ventilatore quadro elettrico
VF = Variatore di frequenza

