

**Hornos Conveccion a Gas
Fours Air ulsé à Gaz
Gas Convection Ovens
Gas-Konvektionsöfen
Forni a Convezione a Gas**

Modelos:

HCG-20/11

VCG-20/11

Mayo 2003 May



Fagor Industrial

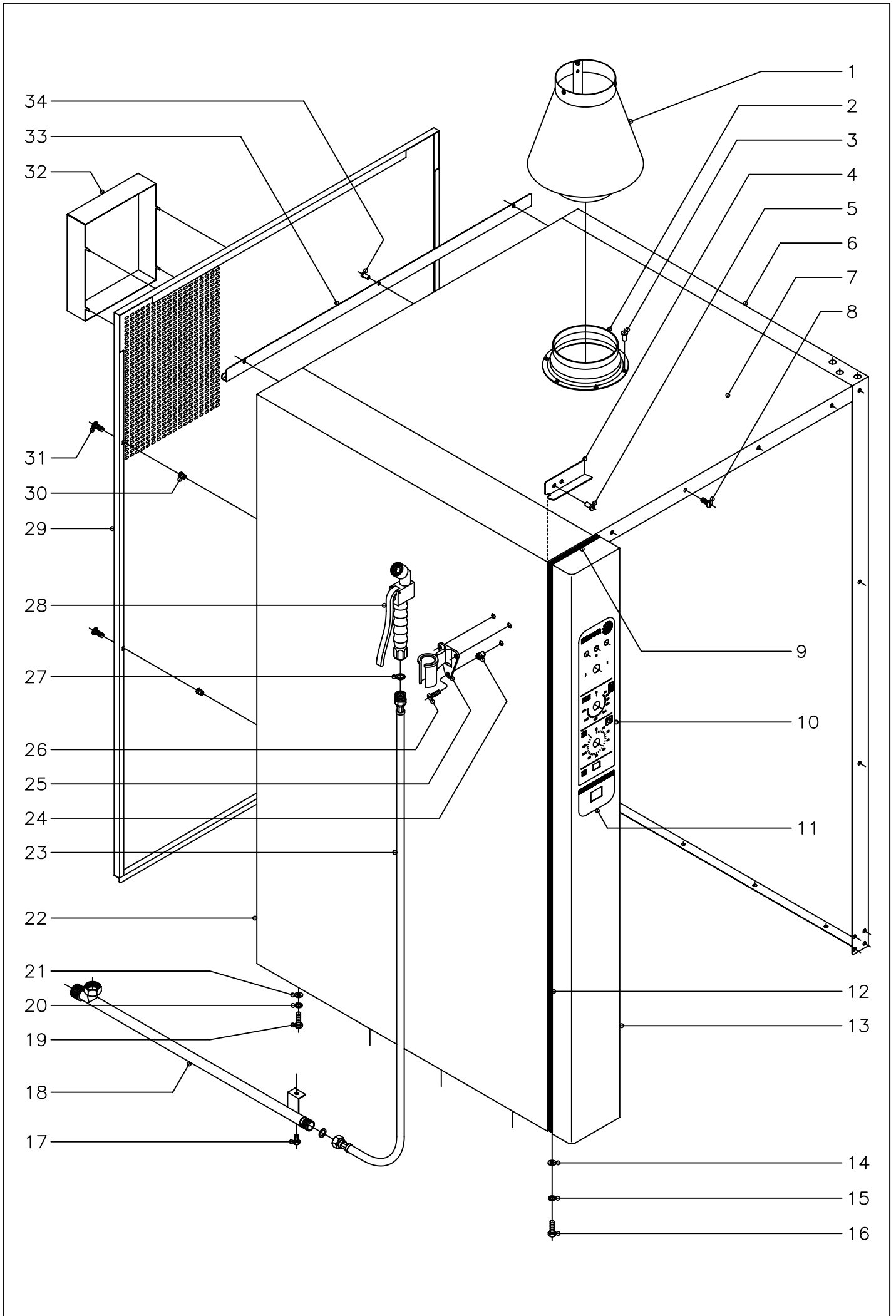

N plano C-1348	Firma 	Fecha 5-2003	Aparato MUEBLE HORNOS A GAS HCG-20/11	Lamina 1	Fagor Industrial S.Coop. FAGOR Oñate
-------------------	----------------------------------------------------------------------------------------------	-----------------	---------------------------------------------	-------------	------------------------------------------------

MOD.		HORNOS A GAS HCG			ZONA	MUEBLE						PLANO	C-1348
ITEM	CODIGO	DENOMINACION	TEXTO	HCG-20/11									NOTAS
1	R272612	Chimenea		1									
	R292646	Conducto humos		1									
	R272614	Soporte chimenea		3									
	Q412002	Remache tubular Ø 4x7,5		9									
2	R292645	Guia chimenea		1									
3	Q412000	Remache tubular Ø 4x8		6									
4	R662811	Fijacion portamandos		1									
5	Q412002	Remache tubular Ø 4x7,5		2									
6	T102804	Panel lateral derecho		1									
7	T102805	Panel superior		1									
	Q221343	Remache exagonal M-6		4									Amarre panel superior a laterales
	Q232040	Arandela plana A-6		4									Amarre panel superior a laterales
	Q262040	Arandela muelle A-6		4									Amarre panel superior a laterales
	Q012042	Tornillo exagonal M-6x15		4									Amarre panel superior a laterales
8	Q152017	Tornillo amarre M-6x13		7									
9	3715400	Junta panel portamandos L=130		1									
10	T013006	Serigrafia superior		1									
11	R723008	Serigrafia inferior		1									
12	3715400	Junta panel portamandos L=1400		2									
13	T102813	Panel portamandos		1									
14	Q232040	Arandela plana A-6		2									
15	Q262040	Arandela muelle A-6		2									
16	Q012042	Tornillo exagonal M-6x15		2									
17	Q012042	Tornillo exagonal M-6x15		1									Opcional bajo pedido
18	R675002	Suplemento ducha		1									Opcional bajo pedido
19	Q012042	Tornillo exagonal M-6x15		8									
20	Q262040	Arandela muelle A-6		8									
21	Q232040	Arandela plana A-6		8									
22	T102808	Panel lateral izquierdo		1									

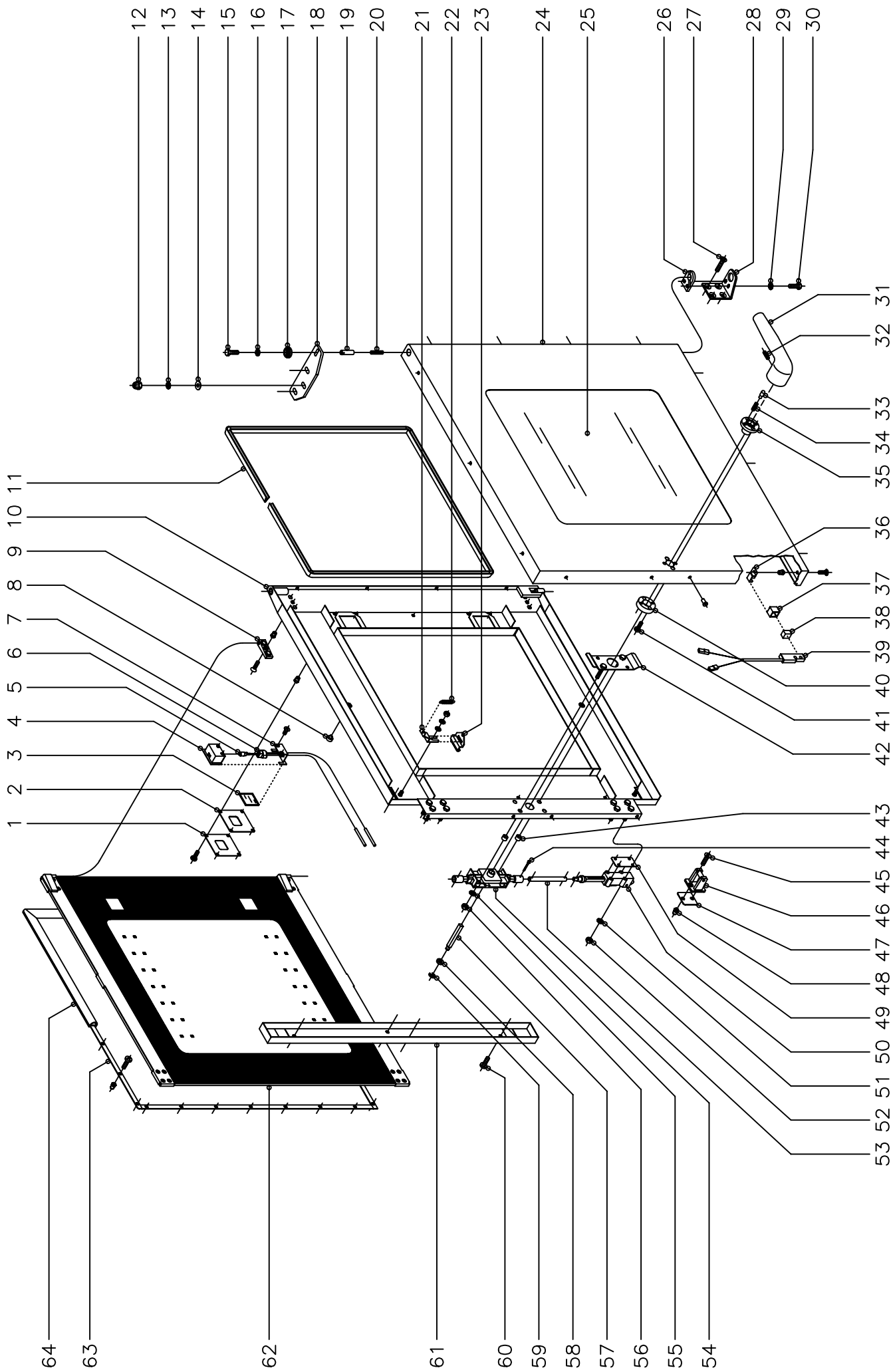

N plano C-1349	Firma 	Fecha 5-2003	Aparato PUERTA HORNOS A GAS HCG-20/11	Lamina 2	Fagor Industrial S.Coop. FAGOR  Oñate
-------------------	----------------------------------------------------------------------------------------------	-----------------	---------------------------------------------	-------------	--------------------------------------------------------------------------------------------------------------------------------------

MOD.		HORNOS A GAS HCG			ZONA	PUERTA						PLANO	C-1349
ITEM	CODIGO	DENOMINACION	TEXTO	HCG-20/11									NOTAS
	1100002597	KIT Puerta completa 20/11		1									
1	R670608	Tapa cierre lampara		2									
	Q032021	Tornillo alomado M-4x10		8									
	Q222041	Remache exagonal M-4		8									
2	R670609	Junta cierre lampara		2									
3	R670618	Cristal de lampara		2									
4	R670610	Deflector de lampara		2									
5	R663013	Lampara 10 W. 12 V.		2									
6	R663058	Portalamparas		2									
7	R670611	Suplemento deflector		2									
	Q042031	Tornillo avellanado M-5x10		4									
8	R670617	Tope cristal interior		8									
9	R670615	Base de bisagra		2									
	Q042032	Tornillo avellanado M-5x15		2									
	Q222011	Remache exagonal M-5		2									
10	T100500	Contrapuerta completa 20/11		1									
11	3715200	Junta cristal L=3200		1									
12	Q212051	Tuerca sombrerete M-8		3									
13	Q242050	Arandela abanico A-8		3									
14	Q302025	Arandela plana Ø8,4xØ20x1,5		3									
15	Q012042	Tornillo exagonal M-6x15		1									
16	Q242040	Arandela abanico A-6		1									
17	R662807	Arandela amarre puerta		1									
18	T130500	Bisagra superior		1									
19	R660534	Eje superior		1									
20	Z850519	Resorte		1									
21	R670612	Base de pestillo		2									
	Q302022	Arandela plana Ø16xØ6x1,2		2									

MOD.	HORNOS A GAS HCG	ZONA	PUERTA	PLANO	C-1349
------	-------------------------	------	---------------	-------	---------------

ITEM	CODIGO	DENOMINACION	TEXTO	HCG-20/11										NOTAS
	Q242040	Arandela abanico A-6		2										
	Q162040	Tuerca exagonal M-6		2										
22	R660605	Muelle tensor pestillo		2										
23	R670613	Pestillo sujecion cristal interior		2										
24	R090600	Panel puerta 20/11		1										
	Q412002	Remache tubular Ø4x7,5		16										
25	R090605	Cristal exterior 20/11		1										
26	R660549	Guia eje inferior		1										
27	Q062040	Tornillo avellanado M-6x16		4										
28	R660551	Bisagra inferior		1										
29	Q242040	Arandela abanico A-6		2										
30	Q012041	Tornillo exagonal M-6x10		2										
31	T130502	Manilla		1										
32	Q132042	Varilla roscada M-6x15		1										
33	T130507	Piton enganche		2										
34	T130506	Resorte		2										
35	T130515	Guia manilla		1										
36	T130513	Soporte iman		1										
37	Z200507	Protector iman		1										
38	Z200506	Iman		1										
39	Z100522	Interruptor magnetico		1										
40	T130514	Soporte resortes		1										
41	Q032032	Tornillo alomado M-5x15		2										
42	T130511	Suplemento fijacion cerradura		1										
43	Z608410	Casquillo		2										
44	Q352001	Pasador de aletas Ø2x15		4										
45	Q042043	Tornillo avellanado M-6x20		4										
46	R260545	Enganche		2										
47	R660538	Calzo de enganche		6										

MOD.		HORNOS A GAS HCG			ZONA	PUERTA						PLANO	C-1349
ITEM	CODIGO	DENOMINACION	TEXTO	HCG-20/11									NOTAS
48	Q221343	Remache exagonal M-6		4									
49	T080503	Suplemento elemento cierre		6									
50	T080504	Elemento de cierre		2									
51	Q262040	Arandela muelle A-6		8									
52	Q162040	Tuerca exagonal M-6		8									
53	R090514	Tubo alargadera		2									
54	T130509	Mecanismo de cierre		1									
55	Q262040	Arandela muelle A-6		2									
56	Q162040	Tuerca exagonal M-6		2									
57	T130508	Eje de manilla		1									
58	T130505	Casquillo		1									
59	Q271033	Arandela de seguridad Ø6		1									
60	Q032031	Tornillo alomado M-5x10		2									
60	Q032021	Tornillo alomado M-4x10		2									
61	T140502	Tapa cierre puerta		1									
62	1100002809	KIT Cristal interior completo 20/11		1									
63	R090512	Fijacion junta completa 20/11		1									
	Q033021	Tornillo alomado M-4x10 (laton)		40									
	Q222041	Remache exagonal M-4 inox.		40									
64	R090510	Junta de puerta 20/11		1									

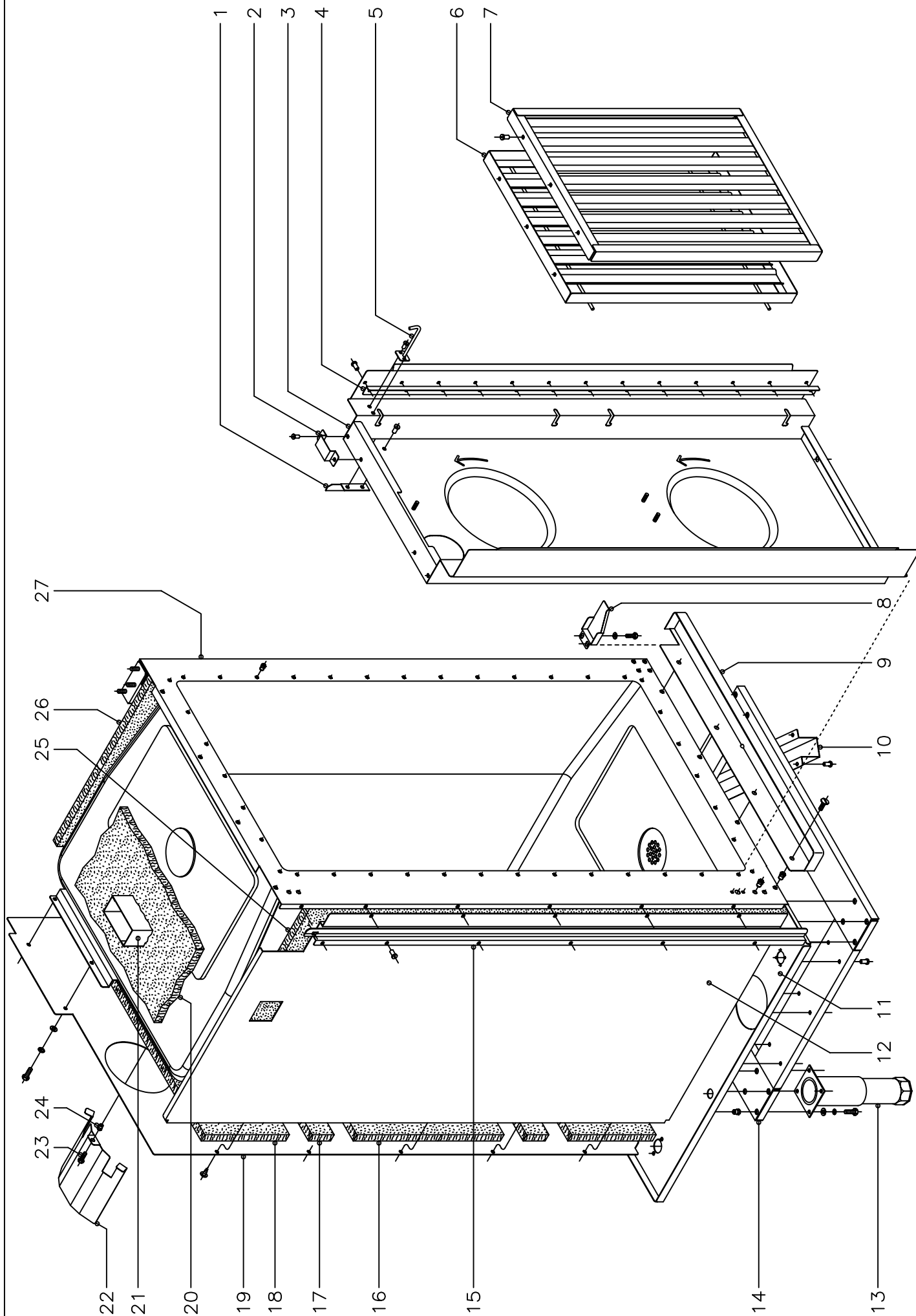

N plano C-1350	Firma 	Fecha 5-2003	Aparato MUEBLE INTERIOR HORNOS A GAS HCG-20/11	Lamina 3	Fagor Industrial S.Coop. FAGOR Onate
-------------------	----------------------------------------------------------------------------------------------	-----------------	------------------------------------------------------	-------------	------------------------------------------------

MOD.	HORNOS A GAS HCG	ZONA	MUEBLE INTERIOR	PLANO	C-1350
------	-------------------------	------	------------------------	-------	---------------

ITEM	CODIGO	DENOMINACION	TEXTO	HCG-20/11										NOTAS
1	R292647	Escuadra sujecion cubreventilador		2										
	Q412002	Remache tubular Ø 4x7,5		4										
2	T122613	Apoyo cubreventilador		2										
	Q412002	Remache tubular Ø 4x7,5		4										
3	T132629	Cubre ventilador		1										
4	R092616	Tope cubreventilador		2										
	Q412002	Remache tubular Ø 4x7,5		26										
5	R142615	Fijacion portabandejas		2										
	Q412002	Remache tubular Ø 4x7,5		4										
6	R092621	Posterior de filtro		2										
7	R092618	Anterior de filtro		2										
	Q412002	Remache tubular Ø 4x7,5		12										
8	R662800	Cubrecables		1										
	Q221342	Remache exagonal M-5		2										
	Q232030	Arandela plana A-5		2										
	Q012031	Tornillo exagonal M-5x10		2										
9	T112813	Recogeaguas		1										
	Q221343	Remache exagonal M-6		4										
	Q152017	Tornillo amarre M-6x13		4										
10	R092819	Cubredesagüe		1										
	Q412002	Remache tubular Ø 4x7,5		8										
11	T102811	Base exterior de horno		1										
12	T132610	Soporte lateral aislante		1										
13	R092830	Pata regulable		4										
	Q012043	Tornillo exagonal M-6x20		16										
	Q262040	Arandela muelle A-6		16										
	Q232040	Arandela plana A-6		16										
	Q221343	Remache exagonal M-6		16										
14	T132816	Refuerzo de apoyos		1										

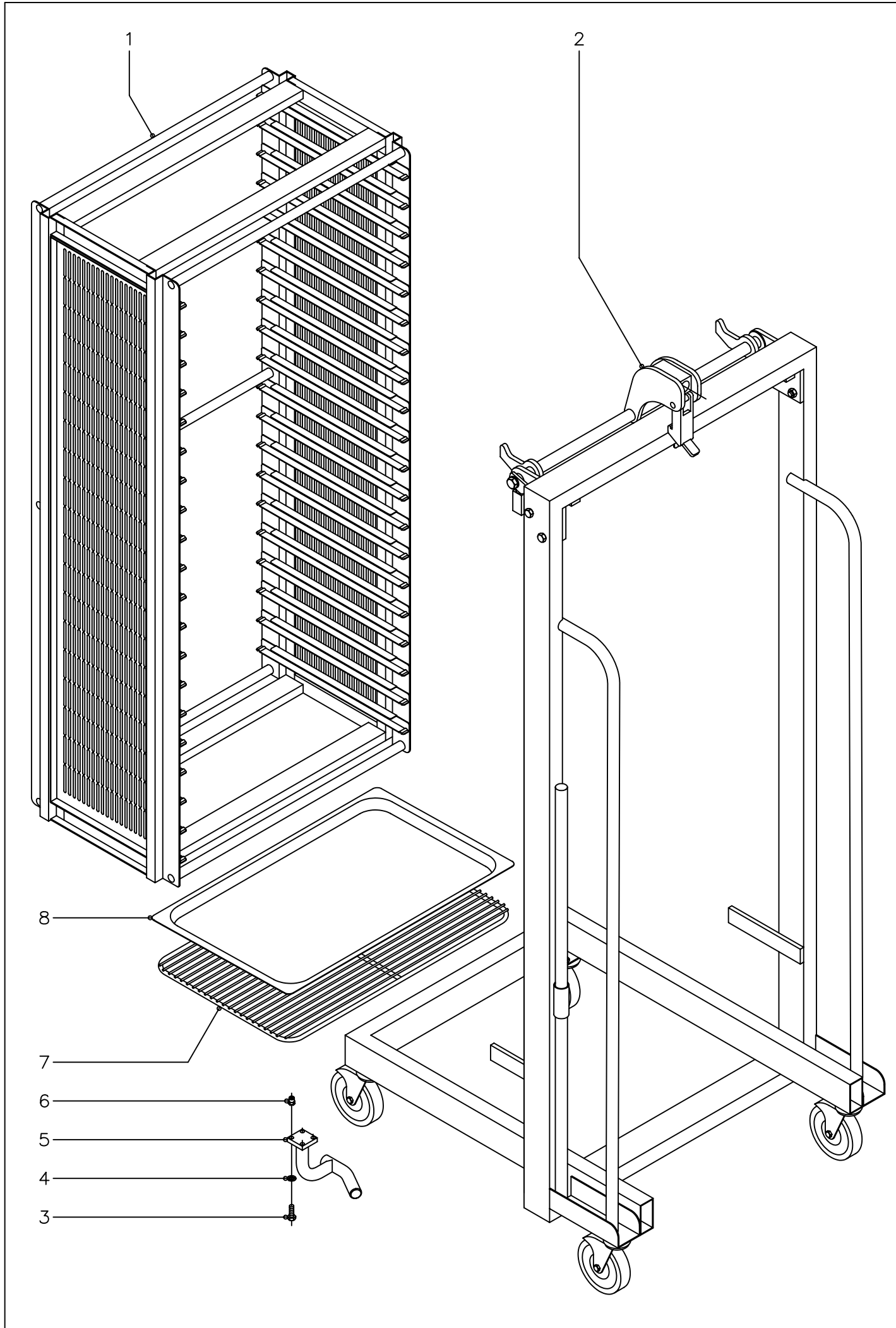

N plano C-1351	Firma 	Fecha 5-2003	Aparato CARRO Y ESTRUCTURA PORTABANDEJAS HORNOS A GAS HCG-20/11	Lamina 4	Fagor Industrial S.Coop. FAGOR  Onate
-------------------	----------------------------------------------------------------------------------------------	-----------------	-----------------------------------------------------------------------	-------------	--------------------------------------------------------------------------------------------------------------------------------------

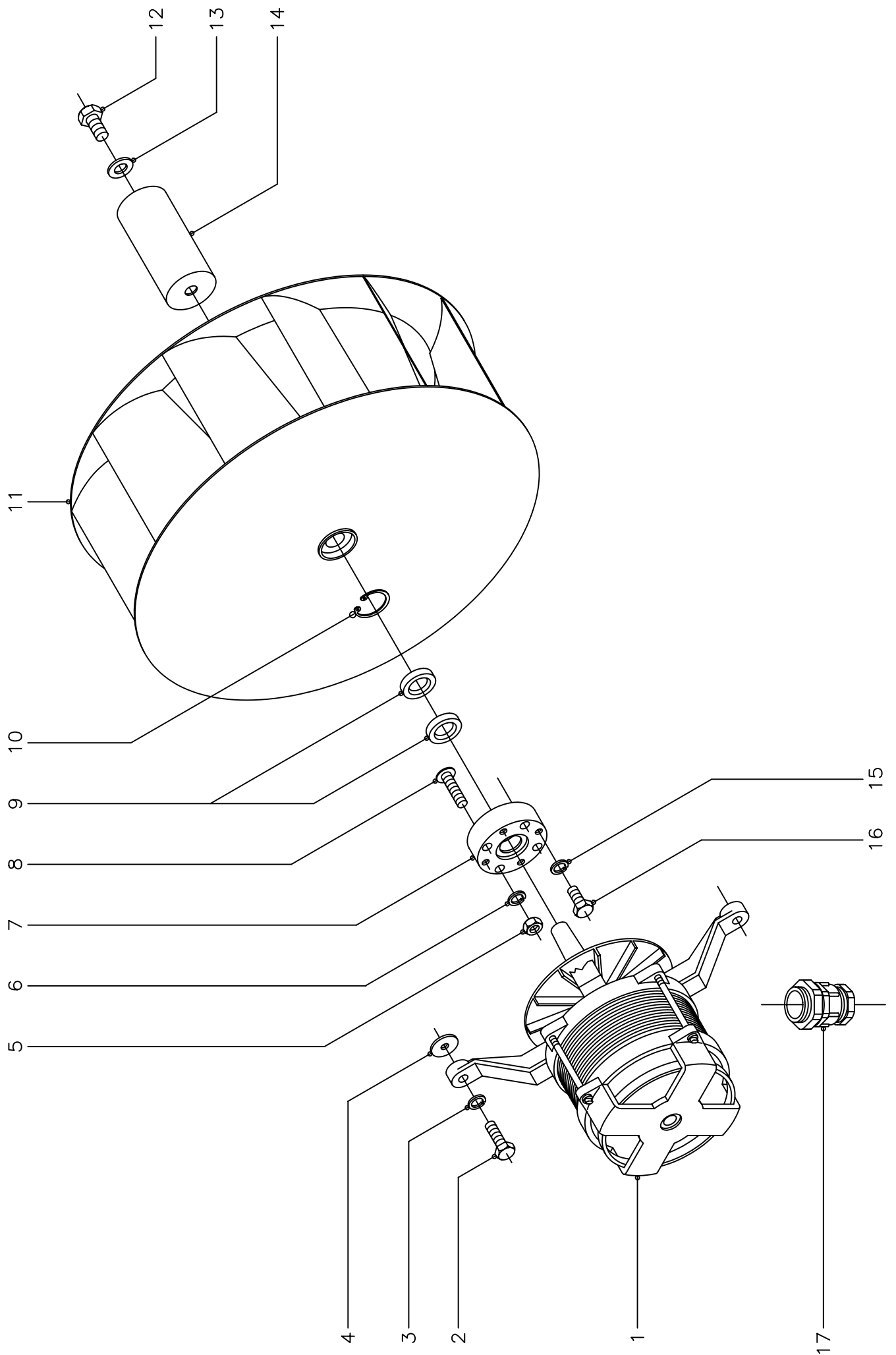

N plano C-1352	Firma 	Fecha 5-2003	Aparato TURBINA HORNOS A GAS HCG-20/11	Lamina 5	Fagor Industrial S.Coop. FAGOR  Oñate
-------------------	----------------------------------------------------------------------------------------------	-----------------	----------------------------------------------	-------------	--------------------------------------------------------------------------------------------------------------------------------------

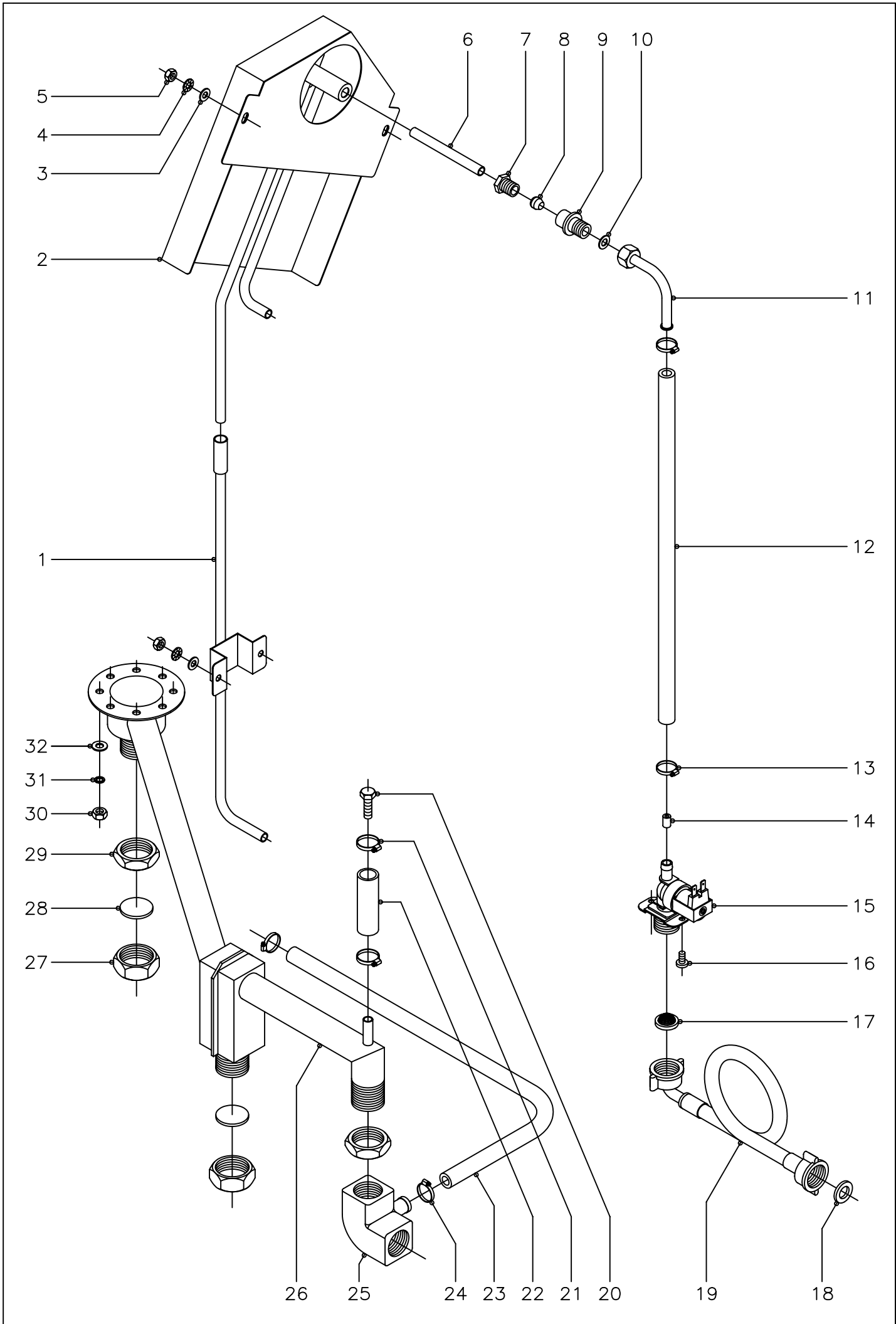

MOD.	HORNOS A GAS HCG	ZONA	CIRCUITO DE AGUA	PLANO	C-1353
------	-------------------------	------	-------------------------	-------	---------------

ITEM	CODIGO	DENOMINACION	TEXTO	HCG-20/11										NOTAS
1	T155012	Alargadera inyector		1										
2	T102608	Conduccion de humos completa		1										
3	Q232030	Arandela plana A-5		4										
4	Q242030	Arandela abanico A-5		4										
5	Q162030	Tuerca exagonal M-5		4										
6	R665024	Tubo conduccion inyector		1										
7	R695003	Manguito cierre		1										
8	R695004	Bicono		1										
9	-	Casquillo soldado a cuerpo horno		1										
10	Q306026	Arandela junta Ø 14xØ 8,5x1,5		1										
11	R695017	Tubo conduccion agua		1										
12	3676900	Tubo goma negra Ø17xØ10x1200		1										
13	Q881302	Abrazadera 12 - 20		2										
14	R715011	Regulador caudal 0,5 l./m. (rojo)		1										
15	Z701135	Electrovalvula entrada agua		1										
16	Q032021	Tornillo alomado M-4x10		2										
17	Z701132	Filtro-junta entrada de agua		1										
18	Q307031	Junta manguera Ø24xØ14x3		1										
19	Z601114	Manguera entrada agua		1										
20	Q012053	Tornillo exagonal M-8x20		1										
21	Q881302	Abrazadera 12 - 20		2										
22	3676900	Tubo goma negra Ø17xØ10x100		1										
23	3715600	Tubo silicona forrado Ø26xØ18x1000		1										
24	Q881304	Abrazadera 20 - 32		2										
25	R665067	Codo desagüe		1										
26	R725004	Tubo desagüe completo		1										
27	R665053	Tuerca tapon		2										
28	R015011	Arandela junta Ø 34x3		2										
29	Q223014	Contratuerca 1"		2										

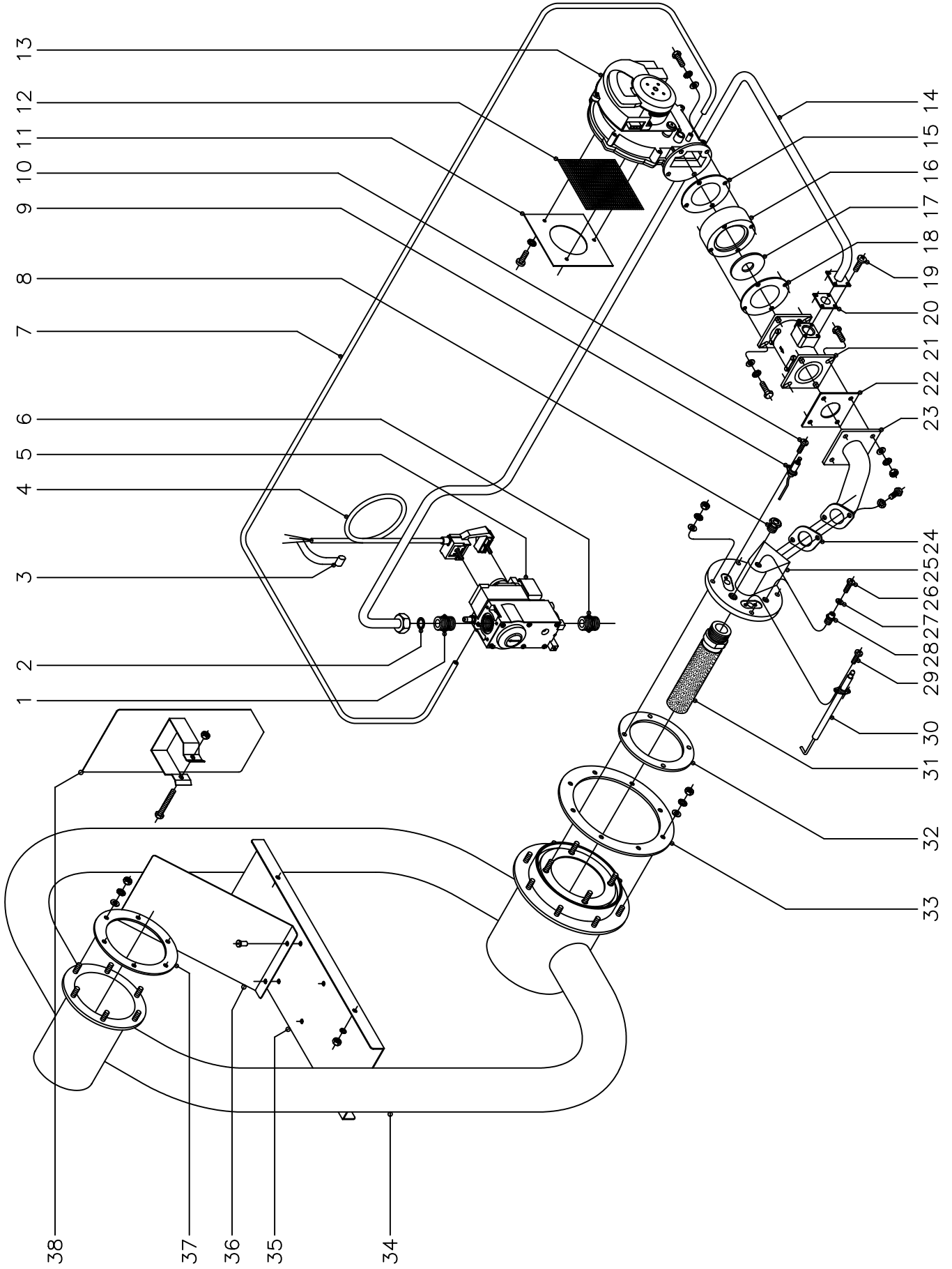

N plano C-1354	Firma 	Fecha 5-2003	Aparato HORNO A GAS HCG-20/11	PARTE FUNCIONAL GAS	Lamina 7	Fagor Industrial S.Coop. FAGOR Onate
-------------------	-----------	-----------------	----------------------------------	---------------------	-------------	------------------------------------------------

MOD.	HORNOS A GAS HCG	ZONA	PARTE FUNCIONAL GAS	PLANO	C-1354
------	------------------	------	---------------------	-------	--------

ITEM	CODIGO	DENOMINACION	TEXTO	HCG-20/11									NOTAS
1	S205023	Manguito doble 1/2"		1									
2	Q306012	Arandela junta Ø18xØ13x1,5		1									
3	Z233012	Condensador antiparasitario		1									
4	T085012	Conector valvula Honeywell		1									
5	T135037	Valvula Honeywell (Regula. a B.P.)		1									(50 Hz.)
5	T135039	Valvula Honeywell (Regula. a G.N.)		1									(50 Hz.)
5	T135040	Valvula Honeywell (Regula. a B.P.)		1									(60 Hz.)
5	T135041	Valvula Honeywell (Regula. a G.N.)		1									(60 Hz.)
6	S205023	Manguito doble 1/2"		1									
7	3702400	Tubo goma negra Ø 8xØ 4x1500		1									
8	R725015	Visor de encendido		1									
9	T135705	Electrodo de deteccion		1									
10	Q153021	Tornillo alomado M-4x10		1									
11	T115096	Chapa amarre malla ventilador		1									
	Q032021	Tornillo alomado M-4x10		3									
	Q242020	Arandela abanico A-4		3									
12	T115095	Malla ventilador		1									
13	T083000	Ventilador E.B.M.-RG130		1									
14	T015000	Conduccion de gas completo		1									
15	T115081	Junta acoplamiento ventilador y mixer		1									
16	T115076	Acoplamiento ventilador mixer		1									
17	T135035	Arandela regulacion ventilad. Ø 22		1									(Butano-Propano
17	T135036	Arandela regulacion ventila. Ø26,3		1									(Gas Natural)
18	T115081	Junta acoplamiento ventilador y mixer		1									
19	Q032021	Tornillo alomado M-4x10		4									
20	T115080	Junta conduccion mixer		1									
21	T115075	Mixer 35 KW.		1									
22	T115079	Junta mixer conducto		1									
23	T115077	Conducto mixer tapa principal		1									

MOD.		HORNOS A GAS HCG			ZONA	PARTE FUNCIONAL GAS						PLANO	C-1354
ITEM	CODIGO	DENOMINACION	TEXTO	HCG-20/11									NOTAS
24	T095021	Junta conducto tapa		1									
25	T115782	Tapa principal		1									
	Q232030	Arandela plana A-5		4									
	Q242030	Arandela abanico A-5		4									
	Q163030	Tuerca exagonal M-5 laton		4									
26	Q152024	Tornillo avellanado M-4x8		2									
27	R725061	Junta toma de presion		2									
28	R725017	Boquilla toma de presion		2									
29	Q153021	Tornillo alomado M-4x10		1									
30	T135706	Electrodo de ignicion		1									
31	T145712	Quemador Furigas (20/11 y 20/21)		1									
32	R725055	Junta de tapa principal		1									
33	T145710	Junta camara combustion		1									
34	T155700	Intercambiador completo		1									
	Q232040	Arandela plana A-6		14									
	Q262040	Arandela muelle A-6		14									
	Q163140	Tuerca exagonal M-6 laton		14									
35	T092615	Separador central		1									
	Q262040	Arandela muelle A-6		2									
	Q162040	Tuerca exagonal M-6		2									
36	T092616	Aleron central		2									
	Q412002	Remache tubular Ø 4x7,5		4									
37	T145711	Junta de colector		1									
38	T152612	Aleron intercambiador		3									
	Q012046	Tornillo exagonal M-6x40		3									
	Q162040	Tuerca exagonal M-6		3									

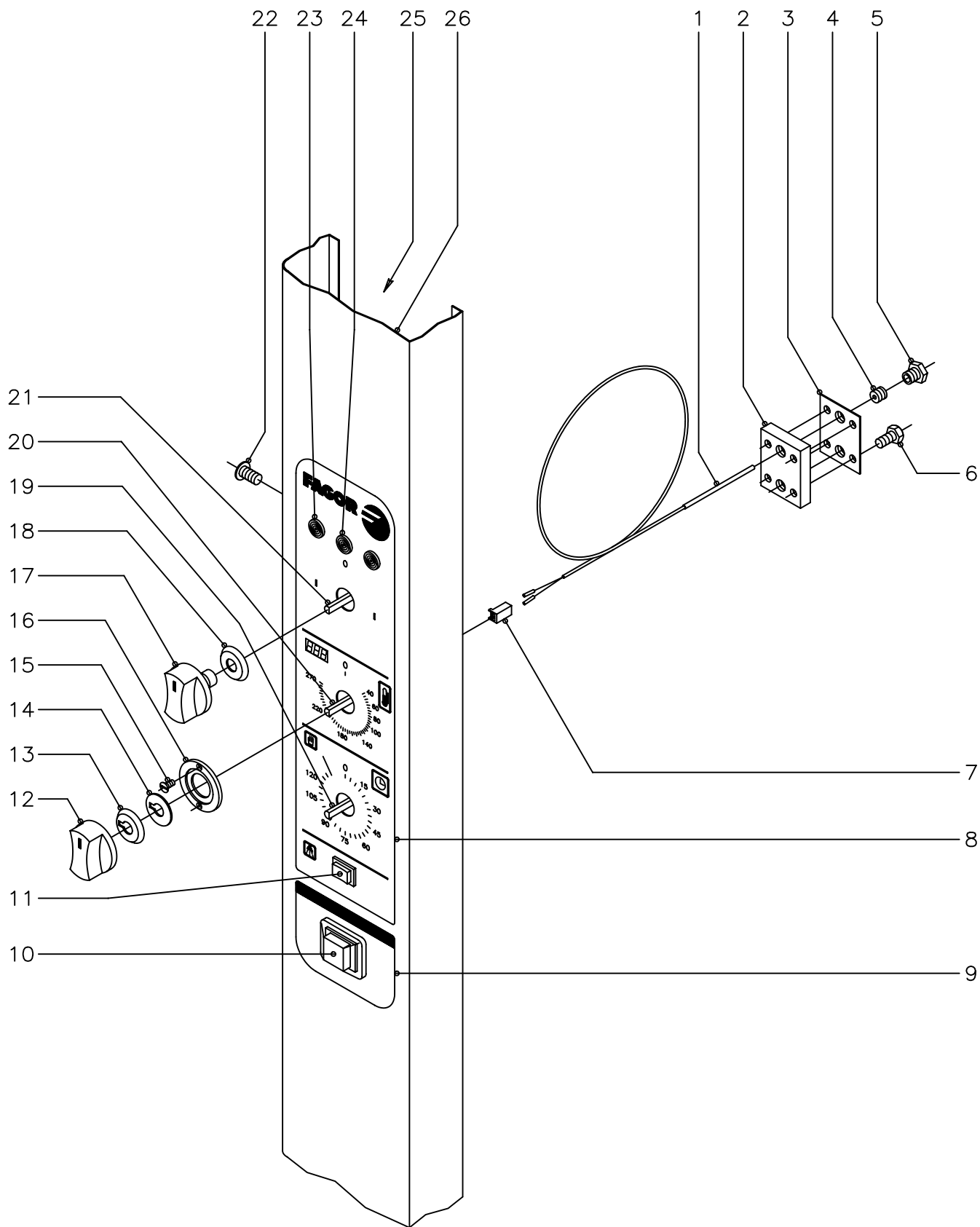

N plano
C-1355

Firma
[Signature]

Fecha
5-2003

Aparato
PARTE ELECTRICA PORTAMANDOS
HORNOS A GAS HCG-20/11

Lamina
8

Fagor Industrial S.Coop. **FAGOR**
Oñate

MOD.		HORNOS A GAS HCG		ZONA	PARTE ELECTRICA PORTAMANDOS							PLANO	C-1355
ITEM	CODIGO	DENOMINACION	TEXTO	HCG-20/11									NOTAS
1	R663090	Conjunto termopar L=1400		1									
2	R662659	Pasamuros doble		1									
3	R692811	Junta pasamuros doble		1									
4	R662652	Bicono cierre sonda		1									
5	R662629	Racord cierre sonda		1									
6	Q012021	Tornillo exagonal M-4x10		4									
7	R663092	Conector 2 vias		1									
8	R723008	Serigrafia inferior		1									
9	T013006	Serigrafia superior		1									
10	Z213033	Pulsador de rearme		1									
11	R663032	Pulsador		1									
12	R663063	Boton de mando Ø6 (termos.elec.)		1									
13	R663045	Junta (termostato electronico)		1									
14	R662810	Arandela guia		1									
15	Q151346	Tornillo avellanado M-3x5		2									
16	R662809	Guia boton de mando		1									
17	R663062	Boton de mando Ø6 (conmutadores)		2									
18	R663046	Junta (conmutadores)		2									
19	R723000	Temporizador manual		1									
20	R743013	Termostato electronico 0 - 270° C.		1									
	R663036	Fijacion circuito termost. electroni.		4									
21	T013001	Conmutador de funciones		1									
22	Q152004	Tornillo aplastado M-5x13		2									
23	R693056	Piloto ambar		2									
24	R693055	Piloto verde		1									
25	T012803	Soporte componentes		1									
26	T102813	Panel portamandos		1									

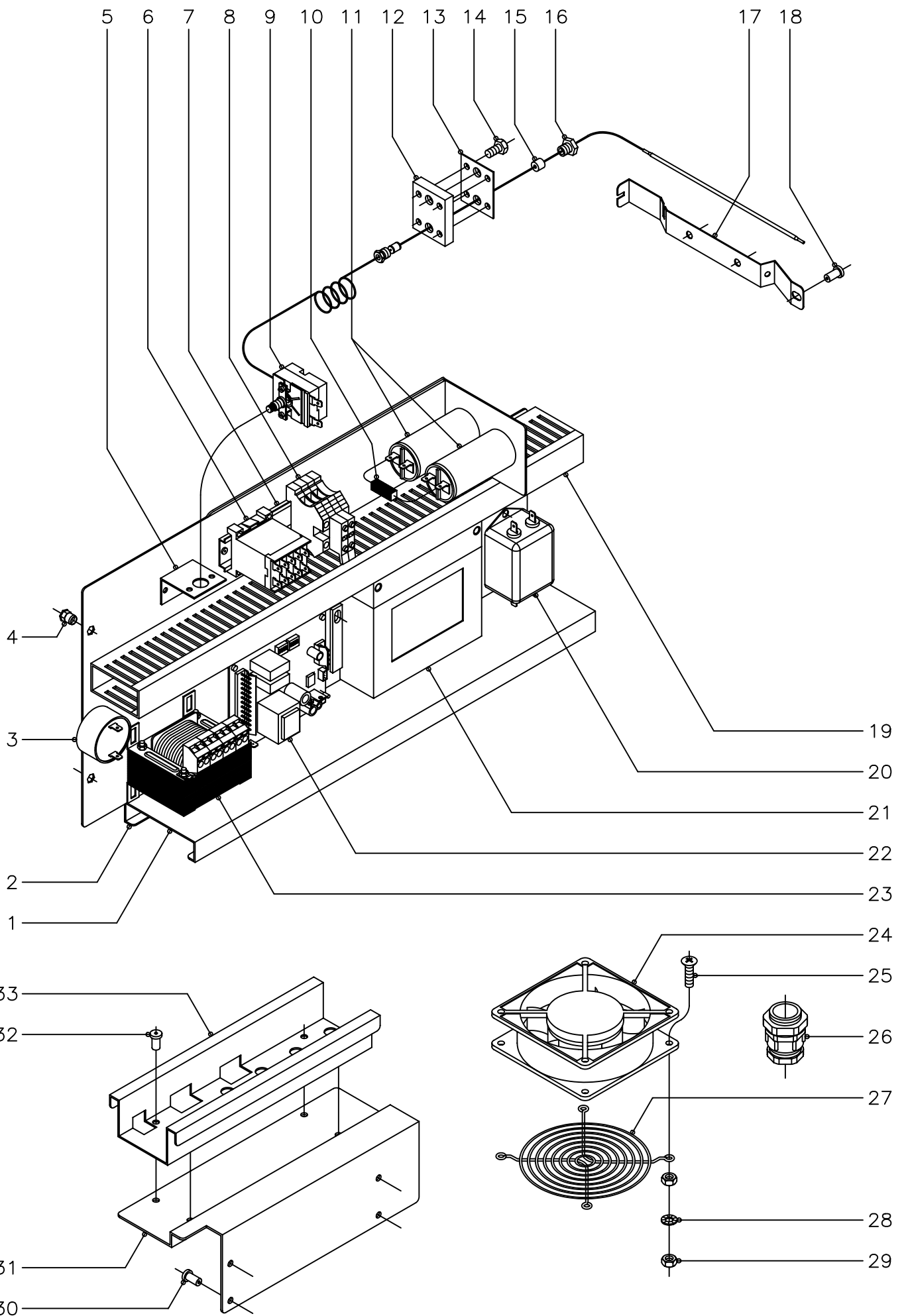

MOD.		HORNOS A GAS HCG			ZONA	PANEL CUADRO ELECTRICO						PLANO	C-1356
ITEM	CODIGO	DENOMINACION	TEXTO	HCG-20/11									NOTAS
1	T083003	Panel cuadro electrico		1									
2	R723101	Contra guia panel cuadro electrico		1									
	Q412002	Remache tubular Ø 4x7,5		8									
3	R693067	Zumbador		1									
4	Q221342	Remache exagonal M-5		2									
5	R343039	Soporte termostato		1									
6	Z683087	Contactador		1									
7	R663055	Guia contactor L=120		1									
8	R073005	Borna portafusible		2									
	R723015	Fusible cristal 10 A.		2									
	P453026	Borne tierra 10		1									
	Z263303	Tope final		1									
9	R243016	Termostato limitador		1									
	Q162050	Tuerca exagonal M-8x1		1									
10	R073008	Cableado PTC		1									
11	T093005	Condensador		2									
12	R662659	Pasamuros doble		1									
13	R692811	Junta pasamuros doble		1									
14	Q012021	Tornillo exagonal M-4x10		4									
15	R662662	Junta cierre bulbo limitador		1									
16	R662629	Racord cierre sonda		1									
17	R662630	Soporte bulbo		1									
18	Q412002	Remache tubular Ø 4x7,5		3									
19	3715520	Canaleta unex (60x30xlonjitud)		4									
20	T113023	Filtro de entrada modelo FF-6Z		1									
21	Z953004	Control combustion		1									
22	T083002	Variador de velocidad		1									
	T133007	Distanciador M-3		4									Amarre variador a cuadro
	T133008	Tornillo amarre M-3x23 (plastico)		4									Amarre variador a cuadro

MOD.	HORNOS A GAS HCG	ZONA	VARIOS	PLANO
------	------------------	------	--------	-------

ITEM	CODIGO	DENOMINACION	TEXTO	HCG-20/11												NOTAS
	T116502	Folleto de instrucciones		1												
	T013044	Esquema electrico adhesivo		1												Plano HC-75723
	T113028	Leyenda esquema electrico		1												Plano HC-75483
	T013046	Esquema electrico de montaje		1												Plano HD-12792
	T013045	Instalacion electrica		1												
	T113035	Cableado luz interior		1												
	R093021	Cableado luz puerta		1												
	3713900	Funda roja o negra Ø 6,4x500		1												
	T123010	Cable de encendido L=2200		1												
	T133033	Cableado variador soplante		1												
	T133001	Cableado conexión 2 motores		1												
	R093004	Cable prolongador		1												

MOD.		HORNOS A GAS HCG		ZONA	PIEZAS ESPECIFICAS PARA LOS DISTINTOS GASES (B.P. Y G.N.) Y DISTINTAS FRECUENCIAS (50 Y 60 Hz.)						PLANO	C-1354
ITEM	CODIGO	DENOMINACION	TEXTO	HCG-20/11								NOTAS
		<u>BUTANO - PROPANO 50 Hz.</u>										
5	T135037	Valvula Honeywell 50Hz. (B.P.)		1								
17	T135035	Arandela regulacion ventilador Ø22		1								
		<u>BUTANO - PROPANO 60 Hz.</u>										
5	T135040	Valvula Honeywell 60Hz. (B.P.)		1								
17	T135035	Arandela regulacion ventilador Ø22		1								
		<u>GAS NATURAL 50 Hz.</u>										
5	T135039	Valvula Honeywell 50Hz. (G.N.)		1								
17	T135036	Arandela regulacion ventilad. Ø26,3		1								
		<u>GAS NATURAL 60 Hz.</u>										
5	T135041	Valvula Honeywell 60Hz. (G.N.)		1								
17	T135036	Arandela regulacion ventilad. Ø26,3		1								

HCG-6/11 HCG-10/11 HCG-10/21 HCG-20/11 HCG-20/21

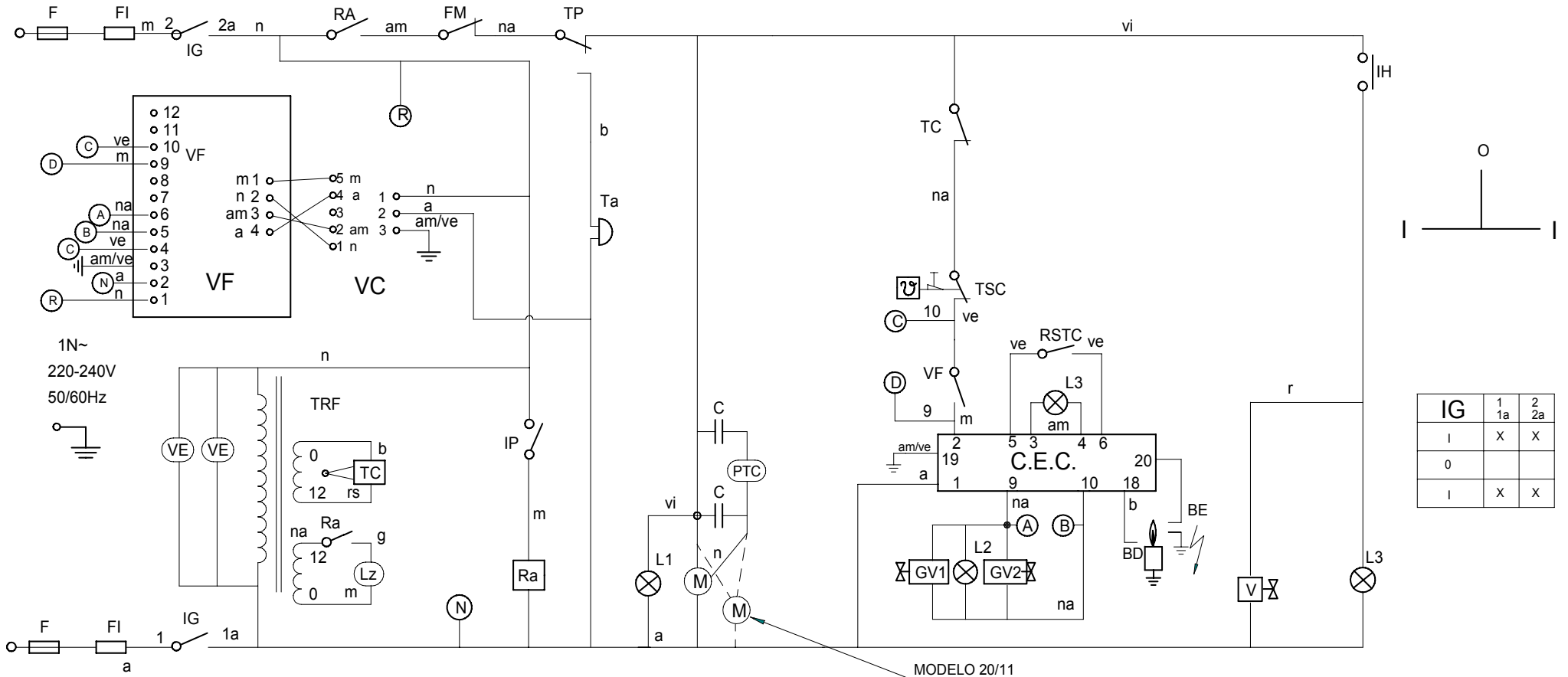

ESQUEMA TEORICO ADHESIVO			T-013044	
Nº	Pieza	Material	Nº Clasificacion	Acabado
Nº	Modificacion	Propuesta de	Fecha	Tolerancias generales
				<5±
				5-25±
				25-50±
				50-100±
				> 100±
				∞±
Dibujado	Firma	Fecha	 Fagor Industrial, Koop. Elk. Mugatua	
Proyectado	KONTXI	5/6/01		
Comprobado				
Escala	<h2>HORNOS HCG</h2>			Plano numero
				HC-75723
				Sustituye al Nº
				Sustituido por

Plano hau ez dateke erabil ez berrizta gure baimenitz gabe

ESPAÑOL

FRANÇAIS

ENGLISH

DEUTSCH

ITALIANO

CODIGO DE COLORES:

r = rojo
a = azul
m = marron
g = gris
n = negro
b = blanco
vi = violeta
am = amarillo
na = naranja
rs = rosa
ve = verde
am/ve = amarillo verde

COMPONENTES:

BD = Bujía de detector de llama
BE = Bujía de Encendido
C = Condensador Motor
C.E.C. = Control Encendido cámara
C.E.V. = Control encendido vapor
CN = Control nivel de agua
① F, F1, F2, F3 = Fusible
FI = Filtro interferencias
FM = Térmico Motor
GV1 = Electroválvula de gas cámara (Control)
GV2 = Electroválvula de gas cámara (Seguridad)
GV4 = Electroválvula de gas vapor (Control)
GV5 = Electroválvula de gas vapor (Seguridad)
la = Micro chimenea abierta
lc = Micro chimenea cerrada
IG = Interruptor general
IP = Interruptor puerta
IR = Selector regulador sonda núcleo
L1 = Lámpara de funcionamiento
L2 = Lámpara calentamiento cámara
L4 = Lámpara entrada de vapor
L3 = Lámpara indicador de bloqueo cámara
L5 = Lámpara indicador de bloqueo vapor
L6 = Lámpara seguridad de vapor
L7 = Lámpara detección de cal
Lz = Luz interior cámara
M = Motor
M1 = Motor accionamiento chimenea
R2, R1, Ra = Relé Auxiliar
RE1 = Regulador de energía
RSTC = Pulsador de rearme cámara
RSTV = Pulsador de rearme vapor
RTS = Regulador sonda núcleo
T100 = Termostato fijo 100°C
Ta = Timbre avisador
TC = Termostato cámara
TCN = Termostato condensación
TDC = Termostato detección de cal
① TP, TMP = Temporizador
① TRF, TRF1 = Transformador
TSC = Termostato seguridad cámara
TSV = Termostato seguridad de vapor
TV = Termostato de vapor
V1 = Electroválvula de agua de llenado
VC = Ventilador centrifugo premezcla
VCN = Electroválvula de agua de condensación
VE = Ventilador cuadro eléctrico
VF = Variador de frecuencia

CODES DE COULEURS:

r = rouge
a = bleu
m = marron
g = gris
n = noir
b = blanc
vi = violet
am = jaune
na = orange
rs = rose
ve = vert
am/ve = jaune/vert

COMPOSANTS:

BD = Veilleuse de détection de flamme
BE = Veilleuse d'allumage
C = Condensateur moteur
C.E.C. = Contrôle d'allumage de chambre
C.E.V. = Contrôle d'allumage de vapeur
CN = Contrôle du niveau d'eau
① F, F1, F2, F3 = Fusible
FI = Filtre interférences
FM = Moteur thermique
GV1 = Electrovalve de chambre gaz (contrôle)
GV2 = Electrovalve de chambre gaz (sécurité)
GV4 = Electrovalve de vapeur gaz (contrôle)
GV5 = Electrovalve de vapeur gaz (sécurité)
la = Micro cheminée ouverte
lc = Micro cheminée fermée
IG = Interrupteur general
IP = Interrupteur de porte
IR = Sélecteur régulateur de sonde noyau
L1 = Lampe de fonctionnement
L2 = Lampe de chauffe chambre
L4 = Lampe d'arrivée de vapeur
L3 = Lampe témoin de blocage de chambre
L5 = Lampe témoin de blocage de vapeur
L6 = Lampe de sureté de vapeur
L7 = Lampe de détection de calcaire
Lz = LumiÈre intérieure de chambre
M = Moteur
M1 = Actionnement moteur de cheminée
R2, R1, Ra = Relais auxiliaire
RE1 = Régulateur d'énergie
RSTC = Bouton de réarmement de chambre
RSTV = Bouton de réarmement de vapeur
RTS = Régulateur de sonde noyau
T100 = Thermostat fixe 100°C
Ta = Sonnerie d'alarme
TC = Thermostat de chambre
TCN = Thermostat de condensation
TDC = Thermostat de détection de calcaire
① TP, TMP = Temporisateur 0-120
① TRF, TRF1 = Transformador
TSC = Thermostat de sureté de chambre
TSV = Thermostat de sureté de vapeur
TV = Thermostat de vapeur
V1 = Electrovalve de remplissage d'eau
VC = Ventilateur de centrifugeuse de prémélange
VCN = Electrovalve de condensation d'eau
VE = Ventilateur tableau électrique
VF = Variador de frecuencia

COLOUR CODE

r = red
a = blue
m = brown
g = grey
n = black
b = white
vi = violet
am = yellow
na = orange
rs = pink
ve = green
am/ve = yellow-green

COMPONENTS:

BD = Flame detector spark plug
BE = Ignition spark plug
C = Motor condenser
C.E.C. = Cooking chamber ignition control
C.E.V. = Steam ignition control
CN = Water level control
① F, F1, F2, F3 = Fusible
FI = Interference filter
FM = Motor thermal switch
Cooking chamber gas solenoid valve (control)
GV2 = Cooking chamber gas solenoid valve (safety)
GV4 = Steam gas solenoid valve (control)
GV5 = Steam gas solenoid valve (safety)
la = Chimney open microswitch
lc = Chimney closed microswitch
IG = Interruptor general
IP = Door switch
IR = Core probe regulator selector
L1 = On/off lamp
L2 = Cooking chamber heating lamp
L4 = Steam inlet lamp
L3 = Cooking chamber lock indicator lamp
L5 = Steam lock indicator lamp
L6 = Steam safety lamp
L7 = Lime detection lamp
Lz = Cooking chamber interior lamp
M = Motor
M1 = Chimney drive motor
R2, R1, Ra = Auxiliary relay
RE1 = Energy regulator
RSTC = Cooking chamber reset button
RSTV = Steam reset button
RTS = Core probe regulator
T100 = Fixed 100°C thermostat
Ta = Warning buzzer
TC = Cooking chamber thermostat
TCN = Condensation thermostat
TDC = Lime detection thermostat
① TP, TMP = 0-120 timer
① TRF, TRF1 = Transformer
TSC = Cooking chamber safety thermostat
TSV = Steam safety thermostat
TV = Steam thermostat
V1 = Water filling solenoid valve
VC = Pre-mix centrifuge fan
VCN = Condensation water solenoid valve
VE = Switchboard fan
VF = Frequency inverter

FARBENCODE

r = rot
a = blau
m = braun
g = grau
n = schwarz
b = weiss
vi = violett
am = gelb
na = orangers
rs = rosa
ve = grün
am/ve = gelb/grün

KOMPONENTEN:

BD = Zündkerze des Flammendetektors
BE = Zündkerze der Zündung
C = Motorkondensator
C.E.C. = Zündkontrolle Kammer
C.E.V. = Zündkontrolle Dampf
CN = Kontrolle Wasserstand
① F, F1, F2, F3 = Fusible
FI = Interferenzfilter
FM = Thermometer
GV1 = Electroventil Gas, Kammer (Kontrolle)
GV2 = Electroventil Gas, Kammer (Sicherheit)
GV4 = Electroventil Gas, Dampf (Kontrolle)
GV5 = Electroventil Gas, Dampf (Sicherheit)
la = Mikroschacht geöffnet
lc = Mikroschacht geschlossen
IG = Hauptschalter
IP = Turschalter
IR = Wahlregler Kernsonde
L1 = Funktionsleuchtanzeige
L2 = Erwärmungsleuchtanzeige Kammer
L4 = Leuchtanzeige Dampftritt
L3 = Leuchtanzeige Blockierung Kammer
L5 = Leuchtanzeige Blockierung Dampf
L6 = Sicherheitsleuchtanzeige Dampf
L7 = Kalkanzeige
Lz = Innenbeleuchtung Kammer
M = Motor
M1 = Motorantrieb Mikroschacht
R2, R1, Ra = Relé Auxiliar
RE1 = Hilfsrelais
RSTC = Bedienungstaste Durch, Aufladung Kammer
RSTV = Bedienungstaste Durch, Aufladung Dampf
RTS = Kernsondenregler
T100 = Thermostat auf 100°C
Ta = Meldeklögel/Lautwerk
TC = Thermostat Kammer
TCN = Kondensationsthermostat
TDC = Thermostat Kalkanzeige
① TP, TMP = Zeitschalter 0-120
① TRF, TRF1 = Transformator
TSC = Sicherheitsthermostat Kammer
TSV = Sicherheitsthermostat Dampf
TV = Dampfthermostat
V1 = Elektroventil Wasserfüllung
VC = Zentrifugallüfter Vormischung
VCN = Elektroventil Kondenswasser
VE = Schaltaffventilator
VF = Frequenzwandler

CODICE DEI COLORI:

r = rosso
a = azzurro
m = marrone
g = grigio
n = nero
b = bianco
vi = viola
am = giallo
na = arancione
rs = rosa
ve = verde
am/ve = giallo/verde

COMPONENTI:

BD = Candela del rilevatore di fiamma
BE = Candela d'accensione
C = Condensatore motore
C.E.C. = Controllo accensione cabina
C.E.V. = Controllo accensione vapore
CN = Controllo livello d'acqua
① F, F1, F2, F3 = Fusibile
FI = Filtro interferenze
FM = Termico Motore
GV1 = Elettrovalvola gas cabina (controllo)
GV2 = Elettrovalvola gas cabina (sicurezza)
GV4 = Elettrovalvola gas vapore (controllo)
GV5 = Elettrovalvola gas vapore (sicurezza)
la = Micro camino aperto
lc = Micro camino chiuso
IG = Interruttore generale
IP = Interruttore porta
IR = Selettore regolatore sonda nucleo
L1 = Lampadina di funzionamento
L2 = Lampadina riscaldamento cabina
L4 = Lampadina ingresso vapore
L3 = Lampadina indicatore di blocco cabina
L5 = Lampadina indicatore di blocco vapore
L6 = Lampadina di sicurezza vapore
L7 = Lampadina rilevatore di calcare
Lz = Luce interna cabina
M = Motore
M1 = Motore funzionamento camino
R2, R1, Ra = Relais ausiliario
RE1 = Regolatore d'energia
RSTC = Pulsante di riarmo vapore
RSTV = Regolatore sonda nucleo
RTS = Regolador Sonda Nucleo
T100 = Termostato fisso 100°C
Ta = Campanello avvisatore
TC = Termostato cabina
TCN = Termostato condensazione
TDC = Termostato rilevatore di calcare
① TP, TMP = Timer 0-120
① TRF, TRF1 = Transformador
TSC = Termostato sicurezza cabina
TSV = Termostato sicurezza vaspore
TV = Termostato vapore
V1 = Elettrovalvola acqua di riempimento
VC = Ventilatore centrifuga
VCN = Elettrovalvola acqua di condensazione
VE = Ventilatore quadro elettrico
VF = Variatore di frequenza

20/21 } T-123010
 20/11 }
 10/21 T-113033
 6/11 } T-133032
 10/11 }

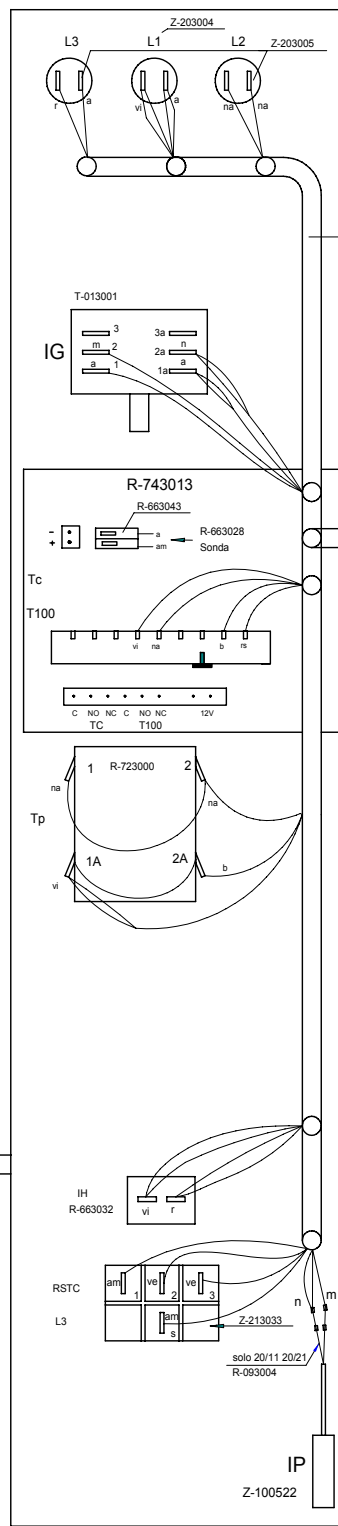
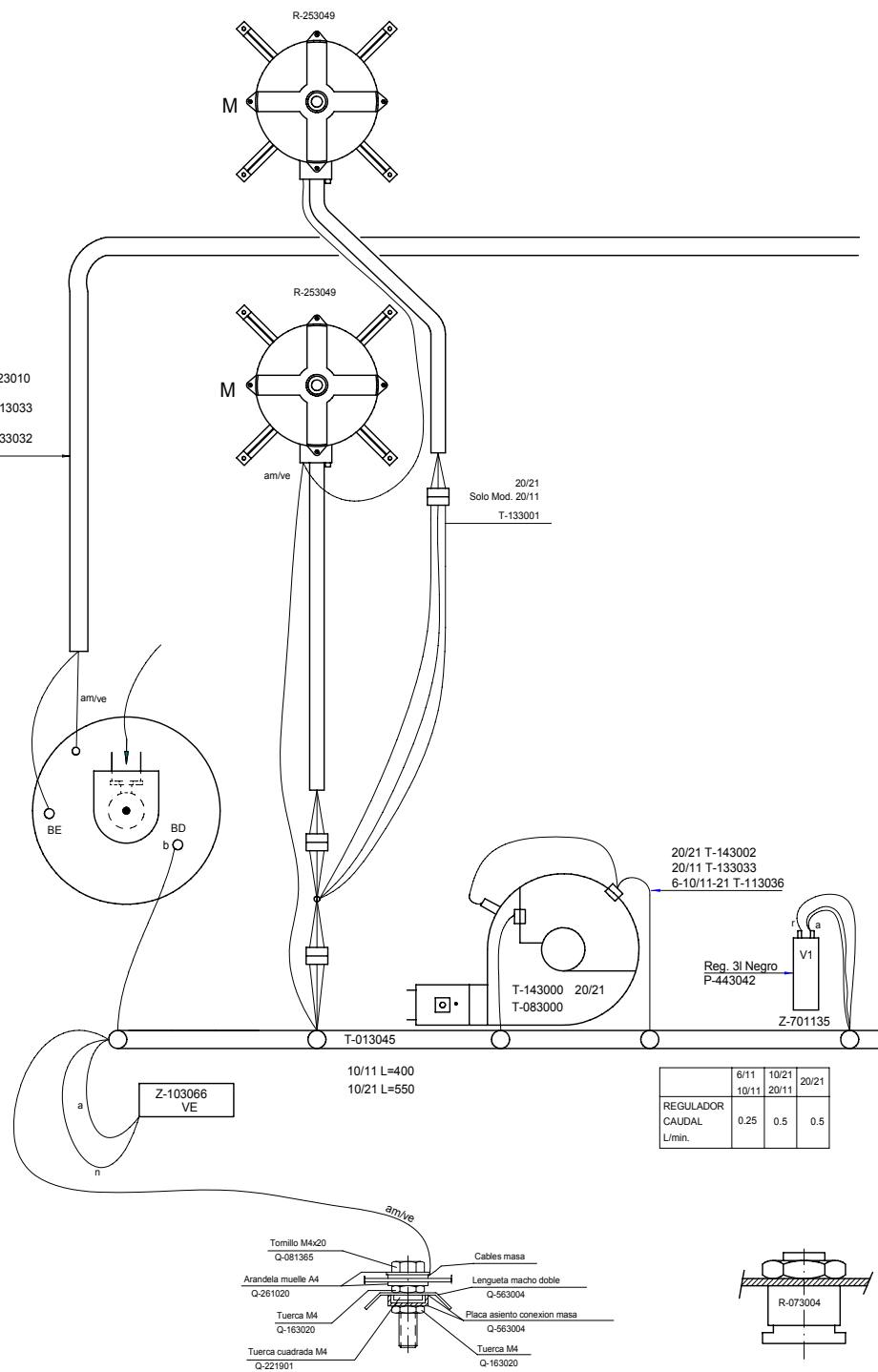

r= rojo - red - rouge
 m= marrón - brown - marrón
 g= gris - grey - gris
 n= negro - black - noir
 a= azul - blue - bleu
 b= blanco - white - blanc

vi= violeta - violette - violet
 am= amarillo - yellow - jaune
 na= naranja - orange - orange
 rs= rosa - rose - pink
 ve= verde - green - vert
 am/ve= amarillo/verde - yellow/green - jaune/vert

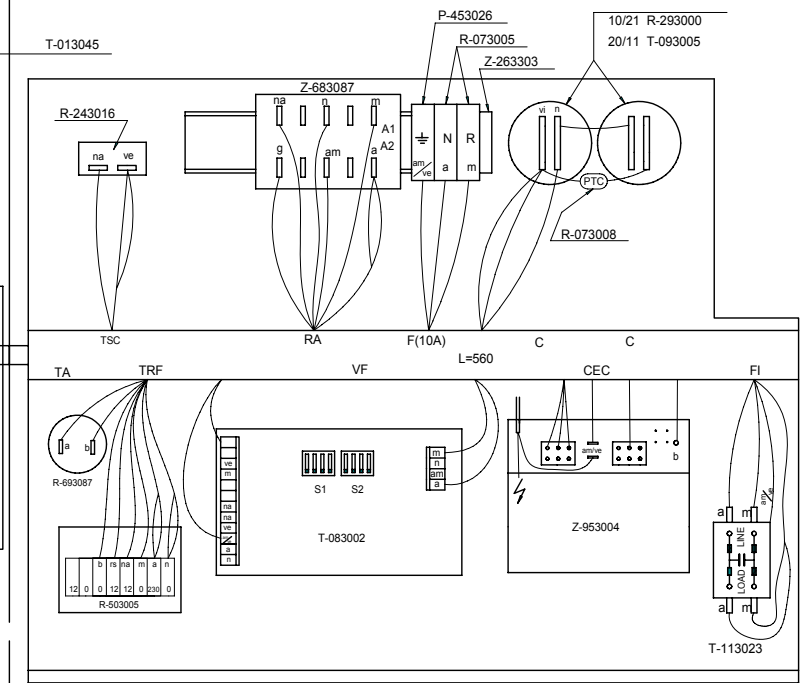

ESQUEMA T-013044
 LEYENDA T-113028
 INDICADOR COMPONENTES T-083038

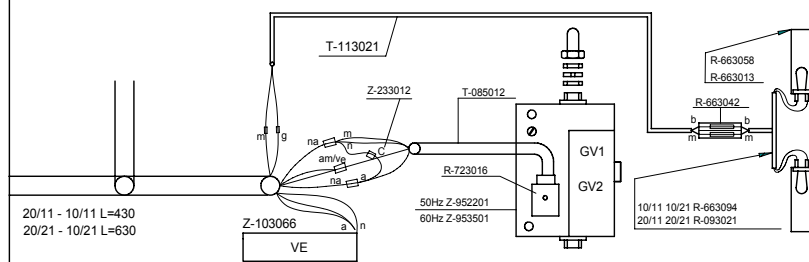

20/11 - 10/11 L=430
 20/21 - 10/21 L=630

Esquema de montaje HCG			T-013046	
Nº	Pieza	Cant.	Material	Nº Clasificación
Nº	Modificación		Propuesta de	Fecha
Tolerancias generadas				
		<5±		50-100±
		5-25±		>100±
		25-50±		<X±
Dibujado		Firma	Fecha	Mecanizado superficial
Proyectado		KONTXI	26/5/01	
Comprobado		Fagor Industrial.Koop.Elk. Mugatua		
Escala		FAGOR		
HORNOS HCG				Plano numero
				HD-12792
Plano hau ez dabilte erabi ez berrita gure baimentz gabe				Sustituye al Nº
				Sustituido por