

**Hornos Mixtos  
Fours Mixtes  
Combi Ovens  
HeiBluftdämpfer  
Forno Misti**

**Modelos:**

**HMM-20/21  
HME-20/21  
HMP-20/21**

**VECM-20/21  
VECE-20/21  
VECP-20/21**

**HMM-20/21 UL**

*Noviembre 2003 November*

**FAGOR** 

**Fagor Industrial**

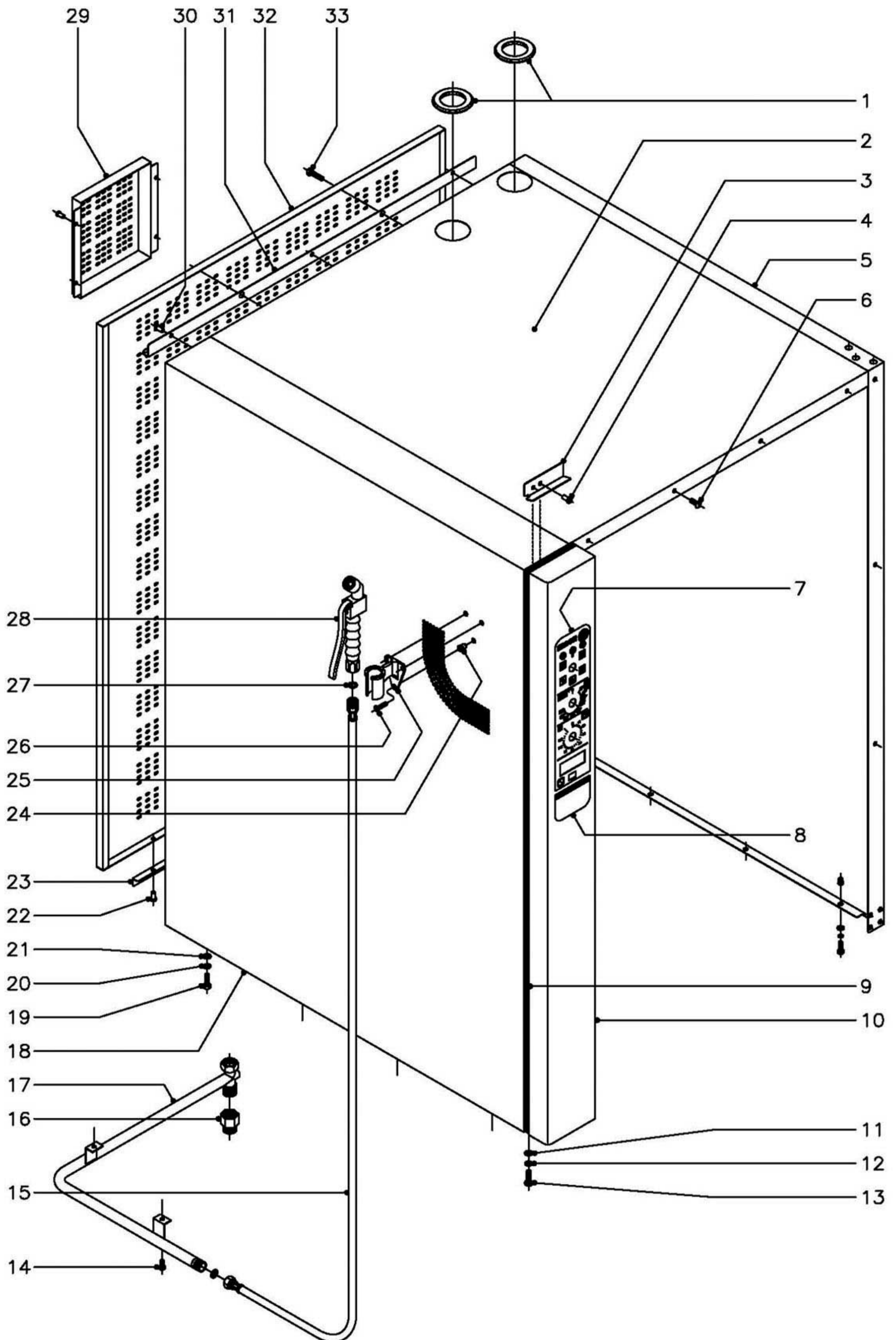

N plano	Firma	Fecha	Aparato	MUEBLE	Lamina	Fagor Industrial S.Coop. <b>FAGOR</b>
C-1469		11-2003	HORNOS HMM, HME, HMP-20/21		1	Ofate

MOD.

HORNOS : HMM, HME, HMP-20/21

ZONA

MUEBLE

PLANO

C-1469

ITEM	CODIGO	DENOMINACION	TEXTO								NOTAS		
				HMM-20/21	HMM-2-20/11	HME-20/21	HME-2-20/11	HMP-20/21	HMP-2-20/11	HMM-20/21UL			
1	R662813	Pasamuros chimenea		2		2		2					
2	R142832	Panel superior		1		1		1					
	Q221343	Remache exagonal M-6		4		4		4					Amarre panel superior a laterales
	Q232040	Arandela plana A-6		4		4		4					Amarre panel superior a laterales
	Q262040	Arandela muelle A-6		4		4		4					Amarre panel superior a laterales
	Q012042	Tornillo exagonal M-6x15		4		4		4					Amarre panel superior a laterales
3	R662811	Fijacion portamandos		1		1		1					
4	Q412002	Remache tubular Ø 4x7,5		2		2		2					
5	R142831	Panel lateral derecho		1		1		1					
6	Q152017	Tornillo amarre M-6x13		7		7		7					
7	R743012	Serigrafia superior ( controlador )		1		-		-					
7	R673000	Serigrafia superior ( controlador )		-		1		1					
7	R743070	Serigrafia superior ( controlador )		-		-		1					
8	R693000	Serigrafia inferior ( conmutador )		1		-		1					
8	R663014	Serigrafia inferior ( neutra )		-		1		-					
8	R663010	Serigrafia inferior ( programador )		-		-		1					
9	3715400	Junta panel portamandos L=130		1		1		1					
9	3715400	Junta panel portamandos L=1400		2		2		2					
10	R772805	Panel portamandos		1		-		1					
10	R092837	Panel portamandos		-		1		1					
11	Q232040	Arandela plana A-6		2		2		2					
12	Q262040	Arandela muelle A-6		2		2		2					
13	Q012042	Tornillo exagonal M-6x15		2		2		2					
14	Q012042	Tornillo exagonal M-6x15		*		1		1					* Opcional bajo pedido
15	R095006	Flexible de ducha		*		1		1					* Opcional bajo pedido
16	T125033	Adaptador a rosca UL		-		-		-					
17	R145041	Suplemento ducha		*		1		1					* Opcional bajo pedido
18	R142807	Panel lateral izquierdo		1		1		1					
19	Q012042	Tornillo exagonal M-6x15		8		8		8					



MOD.

HORNOS : HMM, HME, HMP-20/21

ZONA

MUEBLE

PLANO

C-1469

ITEM	CODIGO	DENOMINACION	TEXTO	HMM-20/21	HMM-2-20/11	HME-20/21	HME-2-20/11	HMP-20/21	HMP-2-20/11	HMM-20/21UL						NOTAS
20	Q262040	Arandela muelle A-6		8		8		8		8						
21	Q232040	Arandela plana A-6		8		8		8		8						
22	Q412002	Remache tubular Ø 4x7,5		4		4		4		4						
23	R142804	Fijacion panel posterior		2		2		2		2						
24	Q221341	Remache exagonal M-4		*		3		3		3						* Opcional bajo pedido
25	R095007	Soporte de ducha		*		1		1		1						* Opcional bajo pedido
26	Q042022	Tornillo avellanado M-4x15		*		3		3		3						* Opcional bajo pedido
27	Q306024	Arandela junta Ø18xØ12,5x1,5		*		2		2		2						* Opcional bajo pedido
28	R095005	Cuerpo de ducha		*		1		1		1						* Opcional bajo pedido
29	R092822	Tapa ventilacion motor		2		2		2		2						
	Q412002	Remache tubular Ø 4x7,5		8		8		8		8						
30	Q412002	Remache tubular Ø 4x7,5		3		3		3		3						
31	R142825	Protector superior		1		1		1		1						
32	R142827	Panel posterior exterior		1		1		1		1						
33	Q012044	Tornillo amarre M-6X25		2		2		2		2						
	Q221343	Remache exagonal M-6		2		2		2		2						



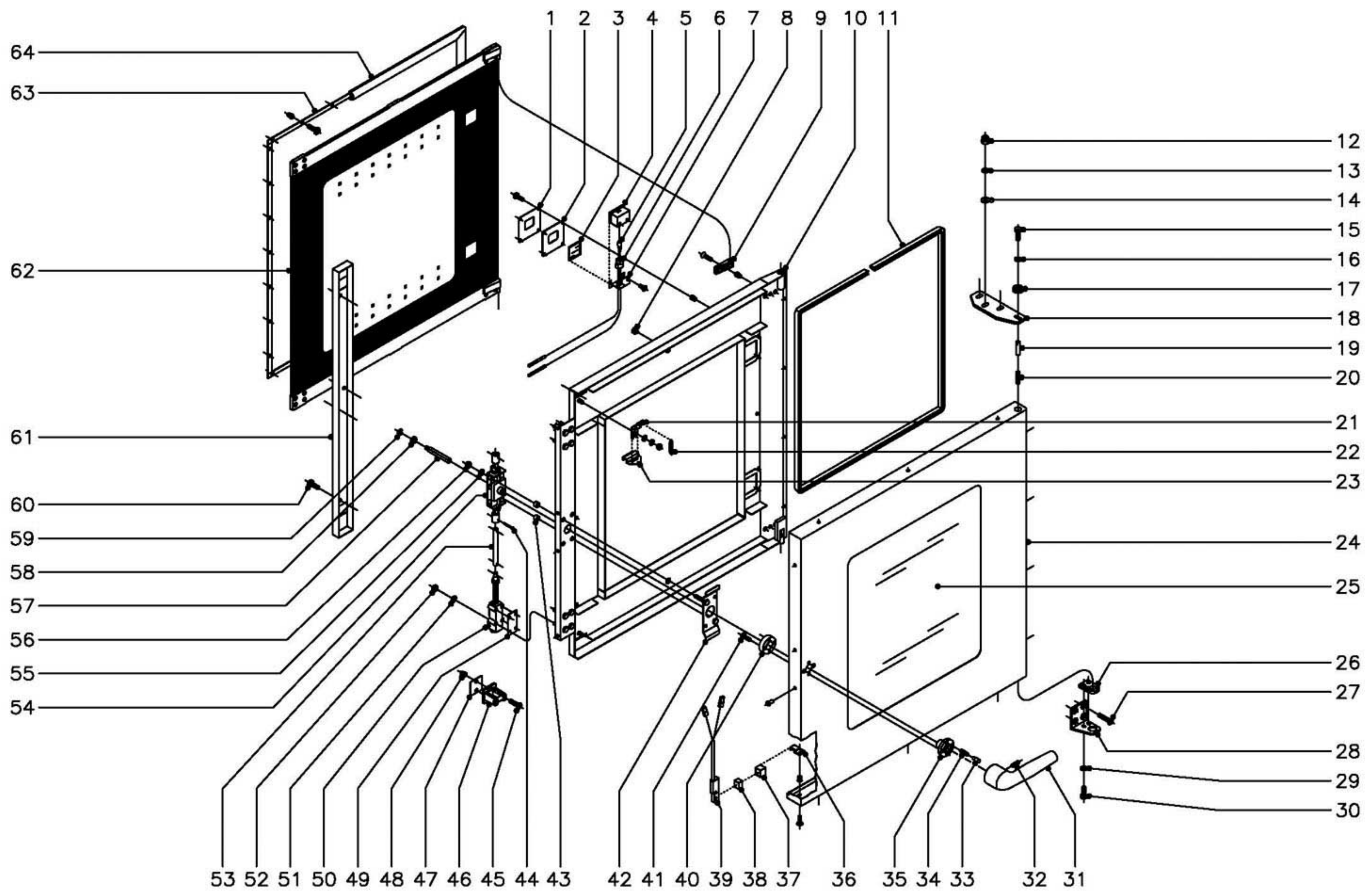

N plano C-1470	Firma 	Fecha 11-2003	Aparato HORNOS HMM, HME, HMP-20/21	PUERTA	Lamina 2	Fagor Industrial S.Coop. <b>FAGOR</b> Orate
-------------------	-----------	------------------	---------------------------------------	--------	-------------	--

MOD.

HORNOS : HMM, HME, HMP-20/21

ZONA

PUERTA

PLANO

C-1470

ITEM	CODIGO	DENOMINACION	TEXTO	HMM-20/21	HMM-2-20/11	HME-20/21	HME-2-20/11	HMP-20/21	HMP-2-20/11	HMM-20/21UL							NOTAS
	1100002598	KIT Puerta completa 20/21		1		1		1		1							
1	R670608	Tapa cierre lampara		2		2		2		2							
	Q152004	Tornillo alomado M-5x13		8		8		8		8							
	Q222011	Remache exagonal M-5		8		8		8		8							
2	R670609	Junta cierre lampara		2		2		2		2							
3	R670618	Cristal de lampara		2		2		2		2							
4	R670610	Deflector de lampara		2		2		2		2							
5	R663013	Lampara 10 W. 12 V.		2		2		2		2							
6	R663058	Portalamparas		2		2		2		2							
7	R670611	Suplemento deflector		2		2		2		2							
	Q042031	Tornillo avellanado M-5x10		4		4		4		4							
8	R670617	Tope cristal interior		8		8		8		8							
9	R670615	Base de bisagra		2		2		2		2							
	Q042032	Tornillo avellanado M-5x15		2		2		2		2							
	Q222011	Remache exagonal M-5		2		2		2		2							
10	R140500	Contrapuerta completa 20/21		1		1		1		1							
11	3715200	Junta cristal L=3400		1		1		1		1							
12	Q212051	Tuerca sombrerete M-8		3		3		3		3							
13	Q242050	Arandela abanico A-8		3		3		3		3							
14	Q302025	Arandela plana Ø8,4xØ20x1,5		3		3		3		3							
15	Q012042	Tornillo exagonal M-6x15		1		1		1		1							
16	Q242040	Arandela abanico A-6		1		1		1		1							
17	R662807	Arandela amarre puerta		1		1		1		1							
18	T130500	Bisagra superior		1		1		1		1							
19	R660534	Eje superior		1		1		1		1							
20	Z850519	Resorte		1		1		1		1							
21	R670612	Base de pestillo		2		2		2		2							
	Q302022	Arandela plana Ø16xØ6x1,2		2		2		2		2							

MOD.		HORNOS : HMM, HME, HMP-20/21		ZONA		PUERTA						PLANO		C-1470	
ITEM	CODIGO	DENOMINACION	TEXTO	HMM-20/21	HMM-2-20/11	HME-20/21	HME-2-20/11	HMP-20/21	HMP-2-20/11	HMM-20/21UL					NOTAS
	Q242040	Arandela abanico A-6		2		2		2		2					
	Q162040	Tuerca exagonal M-6		2		2		2		2					
22	R660605	Muelle tensor pestillo		2		2		2		2					
23	R670613	Pestillo sujecion cristal interior		2		2		2		2					
24	R140600	Panel puerta 20/21		1		1		1		1					
	Q412002	Remache tubular Ø4x7,5		16		16		16		16					
25	R140604	Cristal exterior 20/21		1		1		1		1					
26	R660549	Guia eje inferior		1		1		1		1					
27	Q062040	Tornillo avellanado M-6x16		4		4		4		4					
28	R660551	Bisagra inferior		1		1		1		1					
29	Q242040	Arandela abanico A-6		2		2		2		2					
30	Q012041	Tornillo exagonal M-6x10		2		2		2		2					
31	T130502	Manilla		1		1		1		1					
32	Q132042	Varilla roscada M-6x15		1		1		1		1					
33	T130507	Piton enganche		2		2		2		2					
34	T130506	Resorte		2		2		2		2					
35	T130515	Guia manilla		1		1		1		1					
36	T130513	Soporte iman		1		1		1		1					
37	Z200507	Protector iman		1		1		1		1					
38	Z200506	Iman		1		1		1		1					
39	Z100522	Interruptor magnetico		1		1		1		1					
40	T130514	Soporte resortes		1		1		1		1					
41	Q032032	Tornillo alomado M-5x15		2		2		2		2					
42	T130511	Suplemento fijacion cerradura		1		1		1		1					
43	Z608410	Casquillo		2		2		2		2					
44	Q352001	Pasador de aletas Ø2x15		4		4		4		4					
45	Q042043	Tornillo avellanado M-6x20		4		4		4		4					
46	R260545	Enganche		2		2		2		2					
47	R660538	Calzo de enganche		6		6		6		6					



MOD.

HORNOS : HMM, HME, HMP-20/21

ZONA

PUERTA

PLANO

C-1470

ITEM	CODIGO	DENOMINACION	TEXTO	HMM-20/21	HMM-2-20/11	HME-20/21	HME-2-20/11	HMP-20/21	HMP-2-20/11	HMM-20/21UL								NOTAS
48	Q221343	Remache exagonal M-6		4		4		4		4								
49	T080503	Suplemento elemento cierre		6		6		6		6								
50	T080504	Elemento de cierre		2		2		2		2								
51	Q262040	Arandela muelle A-6		8		8		8		8								
52	Q162040	Tuerca exagonal M-6		8		8		8		8								
53	R090514	Tubo alargadera		2		2		2		2								
54	T130509	Mecanismo de cierre		1		1		1		1								
55	Q262040	Arandela muelle A-6		2		2		2		2								
56	Q162040	Tuerca exagonal M-6		2		2		2		2								
57	T130508	Eje de manilla		1		1		1		1								
58	T130505	Casquillo		1		1		1		1								
59	Q271033	Arandela de seguridad Ø6		1		1		1		1								
60	Q032031	Tornillo alomado M-5x10		2		2		2		2								
60	Q032021	Tornillo alomado M-4x10		2		2		2		2								
61	T140502	Tapa cierre puerta		1		1		1		1								
62	1100002810	KIT Cristal interior completo 20/21		1		1		1		1								
63	R140507	Fijacion junta completa 20/21		1		1		1		1								
	Q033021	Tornillo alomado M-4x10 ( laton )		40		40		40		40								
	Q222041	Remache exagonal M-4 inox.		40		40		40		40								
64	R140506	Junta de puerta 20/21		1		1		1		1								

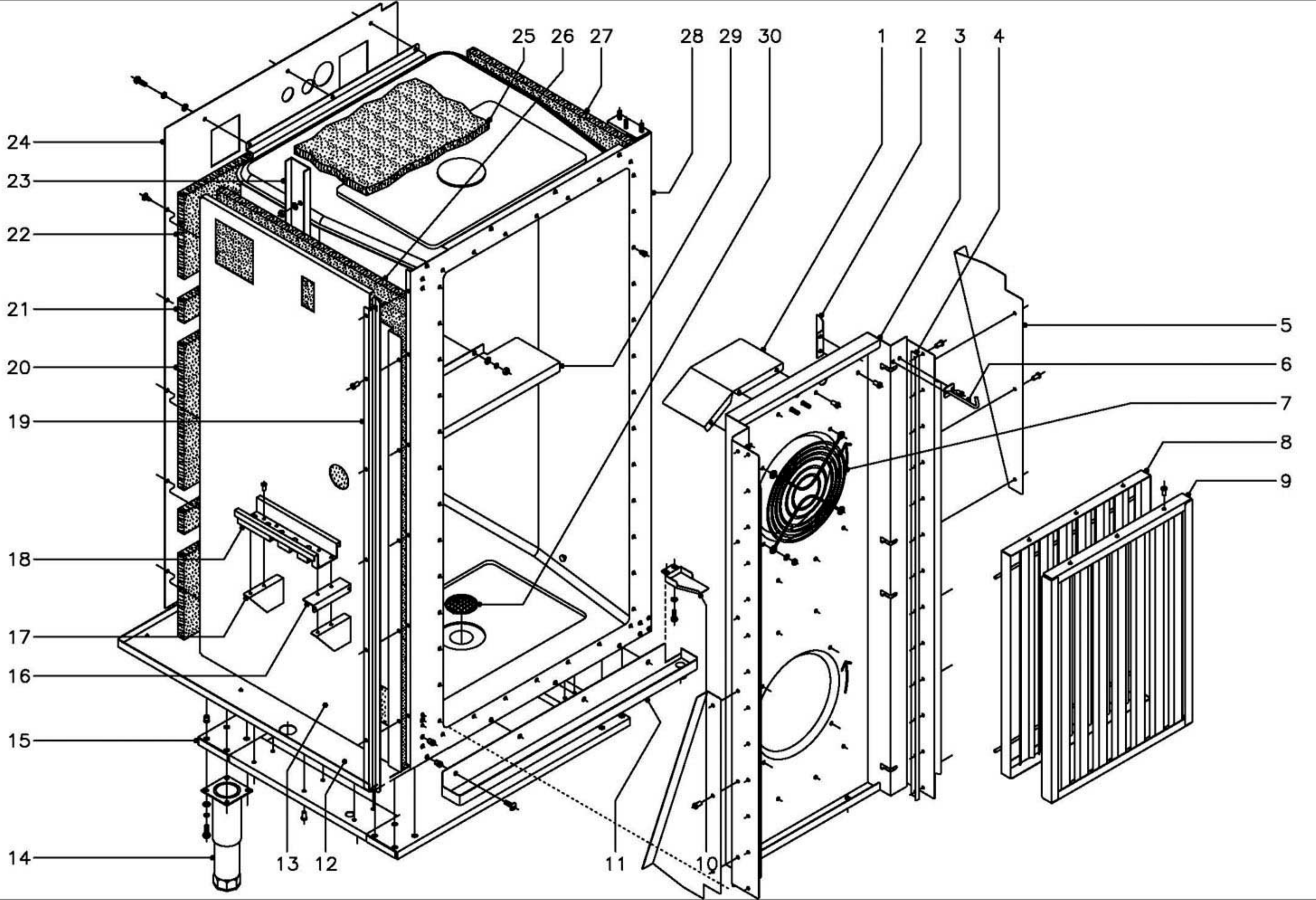

N plano	Firma	Fecha	Aparato	Lamina	Fagor Industrial S.Coop. <b>FAGOR</b>
C-1471		11-2003	MUEBLE INTERIOR HORNOS HMM, HME, HMP-20/21	3	Oñate



MOD.

HORNOS : HMM, HME, HMP-20/21

ZONA

MUEBLE INTERIOR

PLANO

C-1471

ITEM	CODIGO	DENOMINACION	TEXTO								NOTAS		
				HMM-20/21	HMM-2-20/11	HME-20/21	HME-2-20/11	HMP-20/21	HMP-2-20/11	HMM-20/21UL			
1	R682632	Deflector turbina		4		4		4					
	Q412002	Remache tubular Ø 4x7,5		12		12		12					
2	R292647	Escuadra sujecion cubreventilador		2		2		2					
	Q412002	Remache tubular Ø 4x7,5		4		4		4					
3	R142603	Cubre ventilador		1		1		1					
4	R092616	Tope cubreventilador		2		2		2					
	Q412002	Remache tubular Ø 4x7,5		26		26		26					
5	R732619	Aleron lateral		4		4		4					
	Q412002	Remache tubular Ø 4x7,5		12		12		12					
6	R142615	Fijacion portabandejas		2		2		2					
	Q412002	Remache tubular Ø 4x7,5		4		4		4					
7	R662661	Proteccion de turbina		-		-		-		1			
	Q032021	Tornillo alomado M-4x10		-		-		-		4			
	Q242020	Arandela abanico A-4		-		-		-		4			
	Q162020	Tuerca exagonal M-4		-		-		-		4			
8	R092621	Posterior de filtro		2		2		2		2			
9	R092618	Anterior de filtro		2		2		2		2			
	Q412002	Remache tubular Ø 4x7,5		12		12		12		12			
10	R662800	Cubrecables		1		1		1		1			
	Q221342	Remache exagonal M-5		2		2		2		2			
	Q232030	Arandela plana A-5		2		2		2		2			
	Q012031	Tornillo exagonal M-5x10		2		2		2		2			
11	T142820	Recogeaguas		1		1		1		1			
	Q221343	Remache exagonal M-6		4		4		4		4			
	Q152017	Tornillo amarre M-6x13		4		4		4		4			
12	R142830	Base exterior de horno		1		1		1		1			
13	T152604	Soporte lateral aislante		1		1		1		1			
14	R092830	Pata regulable		4		4		4		4			
	Q012043	Tornillo exagonal M-6x20		16		16		16		16			



MOD.

HORNOS : HMM, HME, HMP-20/21

ZONA

MUEBLE INTERIOR

PLANO

C-1471

ITEM	CODIGO	DENOMINACION	TEXTO	HMM-20/21	HMM-2-20/11	HME-20/21	HME-2-20/11	HMP-20/21	HMP-2-20/11	HMM-20/21UL							NOTAS
	Q262040	Arandela muelle A-6		16		16		16		16							
	Q232040	Arandela plana A-6		16		16		16		16							
	Q221343	Remache exagonal M-6		16		16		16		16							
15	T152801	Refuerzo de apoyos		1		1		1		1							
	Q412002	Remache tubular Ø 4x7,5		24		24		24		24							
16	R092611	Fijacion a panel lateral		1		1		1		1							
17	R092610	Refuerzo base de cuadro		2		2		2		2							
18	R342821	Guia cuadro electrico		1		1		1		1							
	Q411304	Remache avibulb Ø 4,8		10		10		10		10							
19	R092662	Protector de portamandos		1		1		1		1							
	Q412002	Remache tubular Ø 4x7,5		6		6		6		6							
20	U675605	Aislante central 740x380x20		1		1		1		1							
21	R662616	Aislante entre refuerzos 560x60x20		8		8		8		8							
22	R032625	Aislante supe. e inferi. 760x230x20		2		2		2		2							
23	R142613	Refuerzo vertical		2		2		2		2							
	Q232040	Arandela plana A-6		12		12		12		12							
	Q162040	Tuerca exagonal M-6		12		12		12		12							
24	R142601	Soporte aislante posterior		1		1		1		1							
	Q151301	Tornillo alomado		5		5		5		5							
	Q012042	Tornillo exagonal M-6x15		15		15		15		15							
	Q262040	Arandela muelle A-6		15		15		15		15							
	Q232040	Arandela plana A-6		15		15		15		15							
25	R682623	Aislante base y techo 860x790x20		5		5		5		5							
26	R142608	Aislante lateral 1370x860x20		3		3		3		3							
27	R142608	Aislante lateral 1370x860x20		2		2		2		2							
28	R142625	Cuerpo interior horno		1		1		1		1							
29	R142609	Separador central		1		1		1		1							
	Q232040	Arandela plana A-6		2		2		2		2							
	Q262040	Arandela muelle A-6		2		2		2		2							

**MOD.****HORNOS : HMM, HME, HMP-20/21****ZONA****MUEBLE INTERIOR****PLANO****C-1471****ITEM****CODIGO****DENOMINACION****TEXTO****HMM-20/21****HMM-2-20/11****HME-20/21****HME-2-20/11****HMP-20/21****HMP-2-20/11****HMM-20/21UL****NOTAS**

Q162040

Tuerca exagonal M-6

2

2

2

2

30

R145033

Filtro desague

1

1

1

1



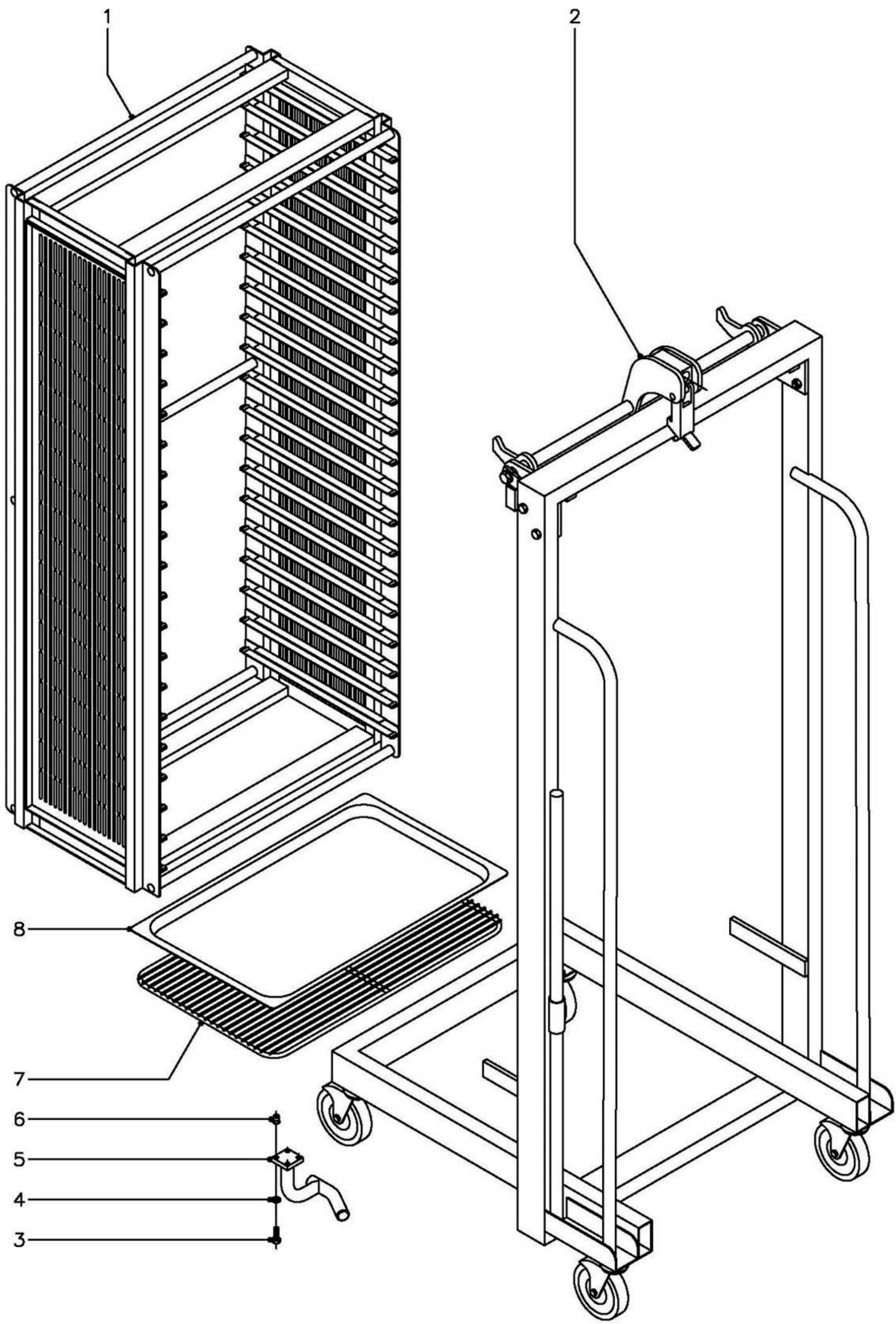

N plano  
C-1472

Firma

Fecha  
11-2003

Aparato CARRO Y ESTRUCTURA PORTABANDEJAS  
HORNOS HMM, HME, HMP-20/21

Lamina  
4

Fagor Industrial S.Coop. **FAGOR**



MOD.

HORNOS : HMM, HME, HMP-20/21

ZONA

CARRO Y ESTRUCTURA PORTABANDEJAS

PLANO

C-1472

ITEM	CODIGO	DENOMINACION	TEXTO	HMM-20/21	HMM-2-20/11	HME-20/21	HMP-20/21	HME-2-20/11	HMP-2-20/11	HMM-20/21UL					NOTAS
1	R145640	Portabandejas 20/21		1	-	1	-	-	-						
1	R145663	Portabandejas 20/21 UL		-	-	-	-	1							
s/n	R145650	Portabandejas 2-20/11		-	1	-	1	-							
2	R145630	Carro portabandejas 20/21		1	1	1	1	1							
3	Q012033	Tornillo exagonal M-5x20		8	8	8	8	8							
4	Q242030	Arandela abanico A-5		8	8	8	8	8							
5	T132815	Suplemento guia izquierda de carro		1	1	1	1	1							
s/n	T132814	Suplemento guia derecha de carro		1	1	1	1	1							
6	Q221342	Remache exagonal M-5		8	8	8	8	8							
7	R682676	Parrilla de horno 2/1		1	-	1	-	10							
s/n	R672665	Parrilla de horno 1/1		-	1	-	1	-							
8	R032605	Bandeja de horno 2/1 P=40		1	-	1	-	-							
s/n	R252816	Bandeja de horno 1/1 P=20		-	1	-	1	-							

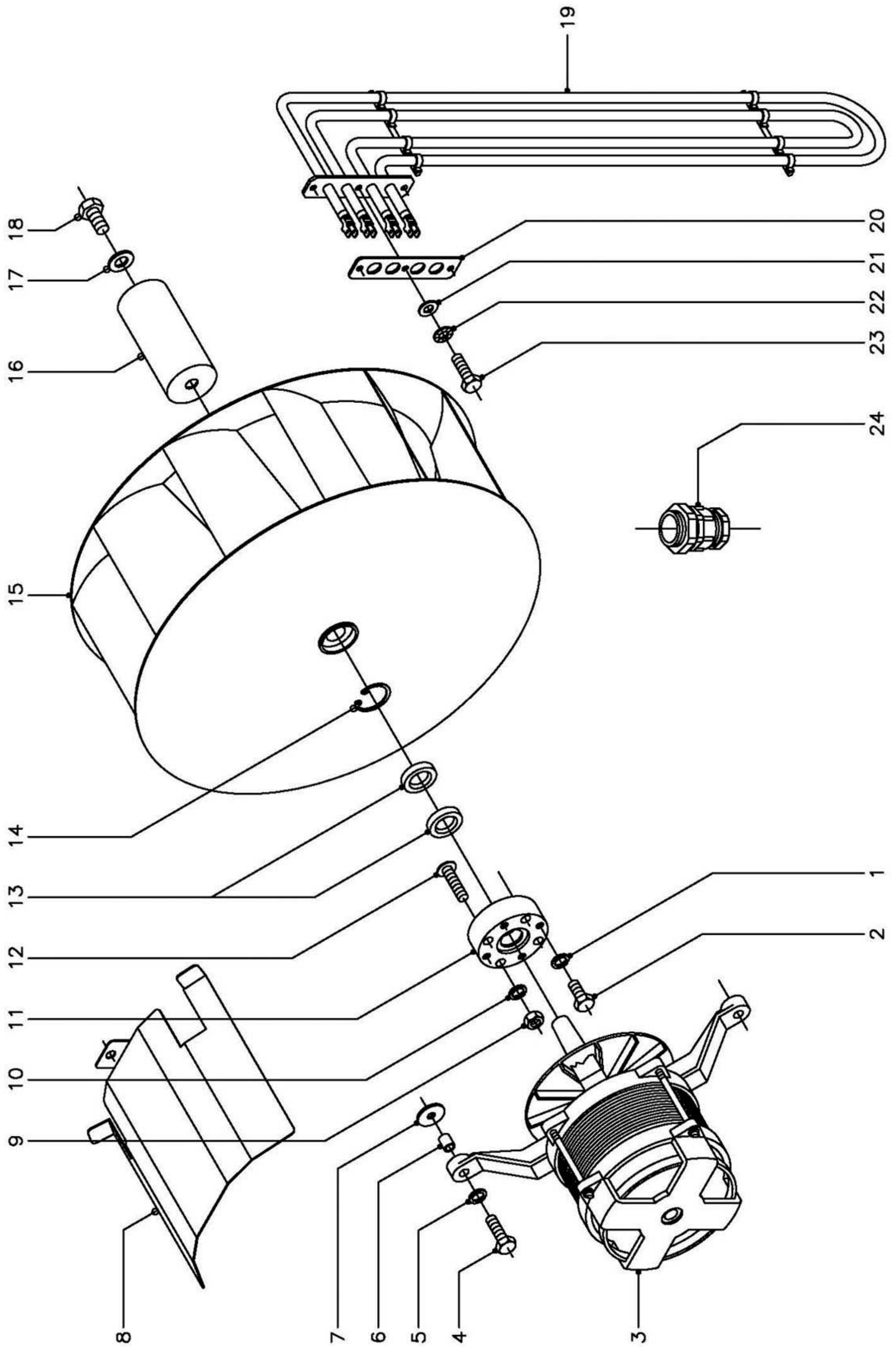

N plano C-1473	Firma 	Fecha 11-2003	Aparato TURBINA HORNOS HMM, HME, HMP-20/21	Lamina 5	Fagor Industrial S.Coop. <b>FAGOR</b> Onate
-------------------	--	------------------	--	-------------	--

MOD.

HORNOS : HMM, HME, HMP-20/21

ZONA

TURBINA

PLANO

C-1473

ITEM	CODIGO	DENOMINACION	TEXTO	HMM-20/21	HMM-2-20/11	HME-20/21	HME-2-20/11	HMP-20/21	HMP-2-20/11	HMM-20/21UL							NOTAS
1	Q232030	Arandela muelle A-5		8		8		8		8							
2	Q012031	Tornillo exagonal M-5x10		8		8		8		8							
3	R253049	Motor (220/240,380/415 V.,50/60 Hz.)		2		-		-		2							Trifasico
3	R663033	Motor ( 380/400 V., 50/60 Hz.)		-		2		2		-							Trifasico
3	R663034	Motor ( 220/230 V., 50/60 Hz.)		-		2		2		-							Trifasico
4	Q012044	Tornillo exagonal M-6x25		8		8		8		8							
5	Q262040	Arandela muelle A-6		8		8		8		8							
6	R663057	Casquillo amarre motor		-		8		8		-							
7	Q301304	Arandela calzo Ø 23xØ 6,5x2		8		8		8		8							
8	R142628	Tejadillo motor		2		2		2		2							
	Q012042	Tornillo exagonal M-6x15		2		2		2		2							
9	Q162040	Tuerca exagonal M-6		8		8		8		8							
10	Q262040	Arandela muelle A-6		8		8		8		8							
11	R662623	Casquillo reten		2		2		2		2							
12	-	Perno M-6 ( Caldeado a cuerpo )		8		8		8		8							
13	R662627	Reten Ø 28xØ 17x7		4		4		4		4							
14	Q302023	Anillo de seguridad Ø 28x1,2		2		2		2		2							
15	R253042	Turbina		2		2		2		2							
16	R665025	Distribuidor inyeccion		-		1		1		-							
17	R763010	Arandela seguridad Hanning		2		2		2		2							
18	Q012063	Tornillo exagonal M-10x20		2		2		2		2							
19	R683000	Resistencia 2000+2000W., 230V.		12		12		12		12							
20	R673063	Junta resistencia		12		12		12		12							
21	Q232030	Arandela plana A-5		36		36		36		36							
22	Q242030	Arandela abanico A-5		36		36		36		36							
23	Q012031	Tornillo exagonal M-5x10		36		36		36		36							
24	R143010	Prensaestopas		1		1		1		1							



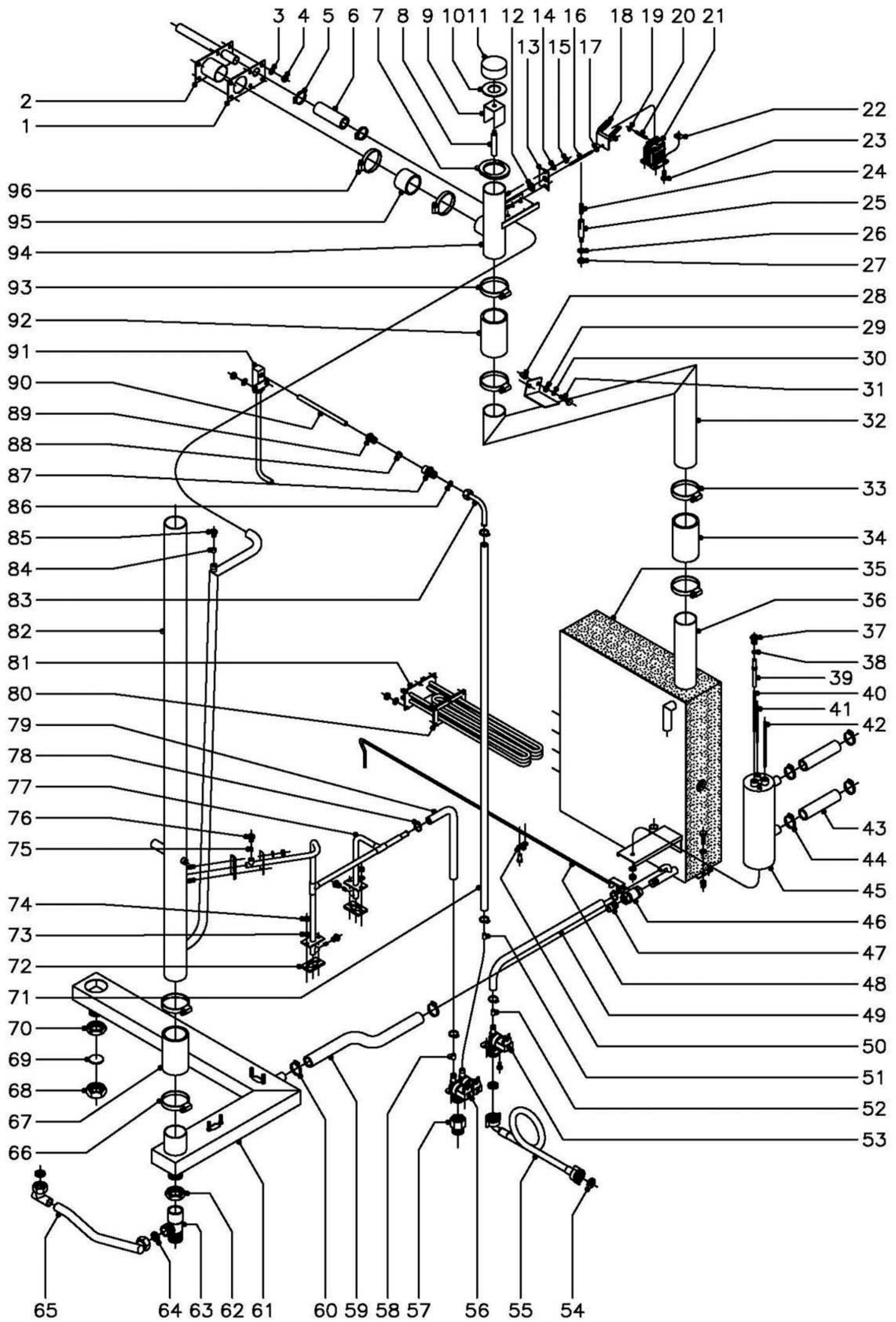

N plano  
C-1474

Firma  

Fecha  
11-2003

Aparato  
HORNOS HMM, HME, HMP-20/21

CIRCUITO DE AGUA

Lamina  
6

Fagor Industrial S.Coop. **FAGOR**  
Oñate 

MOD.

HORNOS : HMM, HME, HMP-20/21

ZONA

CIRCUITO DE AGUA

PLANO

C-1474

ITEM	CODIGO	DENOMINACION	TEXTO	HMM-20/21	HMM-2-20/11	HME-20/21	HME-2-20/11	HMP-20/21	HMP-2-20/11	HMM-20/21UL							NOTAS
1	R675038	Junta entrada y retorno		1		1		1		1							
2	R022613	Tubo entrada y retorno vapor		1		1		1		1							
3	Q232040	Arandela plana A-6		6		6		6		6							
4	Q162040	Tuerca exagonal M-6		6		6		6		6							
5	Q881304	Abrazadera 20 - 32		2		2		2		2							
6	3715600	Tubo silicona forra. Ø26xØ18x100		1		1		1		1							
7	R662813	Pasamuros chimenea		1		1		1		1							
8	R675008	Union retencion de vapores		1		1		1		1							
9	R675005	Guia retencion de vapores		1		1		1		1							
10	R675007	Junta retencion de vapores		1		1		1		1							
11	R675006	Retencion de vapores		1		1		1		1							
12	R675033	Junta palanca accionamiento		1		1		1		1							
13	T115105	Amarre junta a conduccion vahos		1		1		1		1							
14	Q242030	Arandela abanico A-5		2		2		2		2							
15	Q162030	Tuerca exagonal M-5		2		2		2		2							
16	R675014	Palanca accionamiento		1		1		1		1							
17	Q162020	Tuerca exagonal M-4		2		2		2		2							
18	R672640	Escuadra accionamiento		1		1		1		1							
19	Q301035	Sujecion rapida Ø4		2		2		2		2							
20	R675016	Pasador electroiman		1		1		1		1							
21	R663030	Electroiman		1		1		1		1							
22	Q221012	Tuerca rapida M-5		2		2		2		2							
23	Q152004	Tornillo aplastado M-5x13		2		2		2		2							
24	Z883001	Resorte		1		1		1		1							
25	R665027	Guia resorte		1		1		1		1							
26	Q242040	Arandela abanico A-6		1		1		1		1							
27	Q162040	Tuerca exagonal M-6		1		1		1		1							
28	Q221343	Remache exagonal M-6		2		2		2		2							
29	Q232040	Arandela plana A-6		2		2		2		2							



MOD.

HORNOS : HMM, HME, HMP-20/21

ZONA

CIRCUITO DE AGUA

PLANO

C-1474

ITEM	CODIGO	DENOMINACION	TEXTO									NOTAS						
				HMM-20/21	HMM-2-20/11	HME-20/21	HME-2-20/11	HMP-20/21	HMP-2-20/11	HMM-20/21UL								
30	Q262040	Arandela muelle A-6		2		2		2		2								
31	Q012042	Tornillo exagonal M-6x15		2		2		2		2								
32	R145007	Conduccion de vapor		1		1		1		1								
33	Q881324	Abrazadera 50 - 70		2		2		2		2								
34	R345020	Tubo empalme Ø63xØ53x100		1		1		1		1								
35	R145015	Aislante de generador		1		1		1		1								
36	R145001	Generador de vapor		1		1		1		1								
37	R345058	Racord amarre electrodos		3		3		3		3								
38	Q163020	Tuerca exagonal M-4		6		6		6		6								
39	R345059	Guia aislante de electrodos		3		3		3		3								
40	R345063	Electrodo nivel bajo L=116		1		1		1		1								
41	R345060	Electrodo nivel alto L=106		1		1		1		1								
42	R345064	Electrodo de masa L=131		1		1		1		1								
43	3715600	Tubo silicona forra. Ø26xØ18x350		2		2		2		2								
44	Q881304	Abrazadera 20 - 32		4		4		4		4								
45	R025011	Cuerpo de niveles		1		1		1		1								
46	R015034	Cuerpo grifo vaciado		1		1		1		1								
47	R345014	Manguito grifo vaciado		1		1		1		1								
48	R032804	Palanca de grifo de vaciado		1		1		1		1								
49	3676900	Tubo de goma Ø17xØ10x300		1		1		1		1								
50	Q901306	Grapa amarre palanca grifo		1		1		1		1								
	Q412002	Remache tubular Ø4x7,5		2		2		2		2								
51	R665041	Regulador caudal (0,25 l./m.) verde		-		1		1		-								
52	Z601156	Regulador caudal (8 l./m.) rojo		1		1		1		1								
53	Z701135	Electrovalvula simple		1		1		1		1								
	Q032021	Tornillo alomado M-4x10		2		2		2		2								
54	Q307031	Arandela junta Ø24xØ14x3		2		2		2		-								
55	Z601114	Manguera entrada de agua		2		2		2		-								



MOD.

HORNOS : HMM, HME, HMP-20/21

ZONA

CIRCUITO DE AGUA

PLANO

C-1474

ITEM	CODIGO	DENOMINACION	TEXTO	HMM-20/21	HMM-2-20/11	HME-20/21	HME-2-20/11	HMP-20/21	HMP-2-20/11	HMM-20/21UL							NOTAS
56	P255001	Electrovalvula doble		-		1		1		-							
56	Z701135	Electrovalvula simple		1		-		-		1							
	Q032021	Tornillo alomado M-4x10		4		4		4		4							
57	T125033	Adaptador a rosca UL		-		-		-		1							
58	Z601156	Regulador caudal (8 l./m.) rojo		1		1		1		1							
59	3715600	Tubo silicona forra. Ø26xØ18x350		1		1		1		1							
60	Q881304	Abrazadera 20 - 32		2		2		2		2							
61	-	Tubo desague (soldado a cuerpo)		1		1		1		1							
62	Q223014	Contratuerca 1"		1		1		1		1							
63	R145036	Manguito desague		1		1		1		1							
64	Q307031	Arandela junta Ø24xØ14x3		2		2		2		2							
65	R145034	Conduccion recogeaguas		1		1		1		1							
66	Q881324	Abrazadera 50 - 70		2		2		2		2							
67	R345020	Tubo empalme Ø63xØ53x100		1		1		1		1							
68	R665053	Tuerca tapon 1"		1		1		1		1							
69	R015011	Arandela junta tapon Ø34x3		1		1		1		1							
70	Q223014	Contratuerca 1"		1		1		1		1							
71	3676900	Tubo de goma Ø17xØ10x1300		1		1		1		1							
72	R345108	Junta de vahos		3		3		3		3							
73	Q242030	Arandela abanico A-5		6		6		6		6							
74	Q162030	Tuerca exagonal M-5		6		6		6		6							
75	Z651932	Rodete		3		3		3		3							
76	Z651931	Tobera		3		3		3		3							
77	R145024	Conduccion condensacion		1		1		1		1							
78	Q881302	Abrazadera 12 - 20		6		6		6		6							
79	3676900	Tubo de goma Ø17xØ10x300		1		1		1		1							
80	R145012	Junta cierre resistencias		4		4		4		4							
81	R143000	Resistencia (3000W.x3, 230 V.)		4		4		4		4							
	Q232030	Arandela plana A-5		12		12		12		12							

MOD.

HORNOS : HMM, HME, HMP-20/21

ZONA

CIRCUITO DE AGUA

PLANO

C-1474

ITEM	CODIGO	DENOMINACION	TEXTO	HMM-20/21	HMM-2-20/11	HME-20/21	HME-2-20/11	HMP-20/21	HMP-2-20/11	HMM-20/21UL							NOTAS
	Q242030	Arandela abanico A-5		12		12		12		12							
	Q162030	Tuerca exagonal M-5		12		12		12		12							
82	R145000	Retorno chimenea		1		1		1		1							
83	R695017	Tubo conduccion agua		-		1		1		-							
84	3712400	Tubo-junta de silicona Ø8xØ3x20		1		1		1		1							
85	R662629	Racord cierre sonda		1		1		1		1							
86	Q306025	Arandela junta Ø14xØ8,5x1,5		-		1		1		-							
87	-	Soldado a cuerpo de horno		-		1		1		-							
88	R695004	Bicono		-		1		1		-							
89	R695003	Manguito cierre		-		1		1		-							
90	R665024	Tubo conduccion a inyector		-		1		1		-							
91	R675017	Tubo inyector		-		1		1		-							
	Q232030	Arandela plana A-5		-		2		2		-							
	Q162030	Tuerca exagonal M-5		-		2		2		-							
92	R345020	Tubo empalme Ø63xØ53x100		1		1		1		1							
93	Q881324	Abrazadera 50 - 70		2		2		2		2							
94	R675019	Conjunto chimenea		1		1		1		1							
95	3710900	Tubo silicona Ø51xØ43x40		1		1		1		1							
96	Q881307	Abrazadera 40 - 60		2		2		2		2							

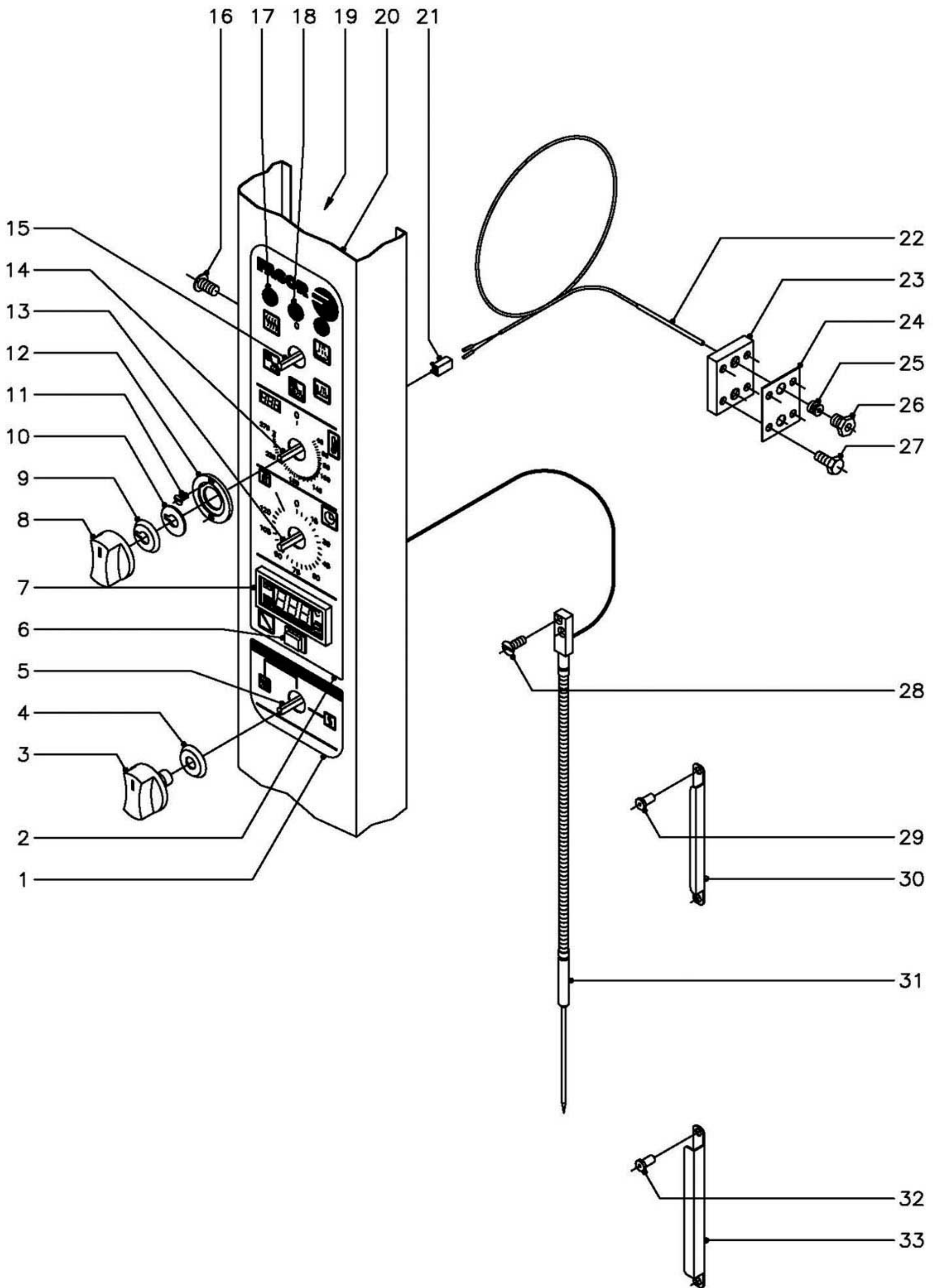

N plano  
C-1475

Firma

Fecha  
11-2003

Aparato  
SISTEMA ELECTRICO PORTAMANDOS  
HORNOS HMM-20/21

Lamina  
7

Fagor Industrial S.Coop. **FAGOR**  
Ofite



MOD.

HORNOS : HMM-20/21

ZONA

SISTEMA ELECTRICO PORTAMANDOS

PLANO

C-1475

ITEM	CODIGO	DENOMINACION	TEXTO	HMM-20/21	HMM-2-20/11	HMM-20/21UL												NOTAS
1	R693000	Serigrafia inferior ( conmutador )		1	1													
2	R743012	Serigrafia superior ( controlador )		1	-													
2	R743070	Serigrafia superior ( controlador )		-	1													
3	R663062	Boton de mando (conmutadores)		3	3													
4	R663046	Junta (conmutadores)		3	3													
5	R753000	Conmutador de potencia		1	1													
6	R743008	Interruptor regulacion sonda		1	1													
7	R743091	Termostato digital ° C.		1	-													
7	R743035	Termostato digital ° F.		-	1													
8	R663063	Boton de mando (circuito impreso)		1	1													
9	R663045	Junta (circuito impreso)		1	1													
10	R662810	Arandela guia		1	1													
11	Q151346	Tornillo avellanado M-3x5		2	2													
12	R662809	Guia boton de mando		1	1													
13	R723000	Temporizador manual		1	1													
14	R743013	Termostato electronico 270°C.		1	-													
14	R693058	Termostato electronico 500°F.		-	1													
15	R743002	Conmutador de funciones		1	1													
16	Q152004	Tornillo aplastado M-5x13		3	3													
17	R693056	Piloto ambar		2	2													
18	R693055	Piloto verde		1	1													
19	R742803	Soporte componentes		1	1													
20	R772805	Panel portamandos		1	1													
21	R663092	Conector 2 vias		1	1													
22	R663090	Conjunto termopar L=1500		1	1													
23	R662659	Pasamuros doble para sonda		1	1													
24	R692811	Junta pasamuros doble		1	1													
25	R662652	Bicono cierre sonda		1	1													
26	R662629	Racord cierre sonda		1	1													



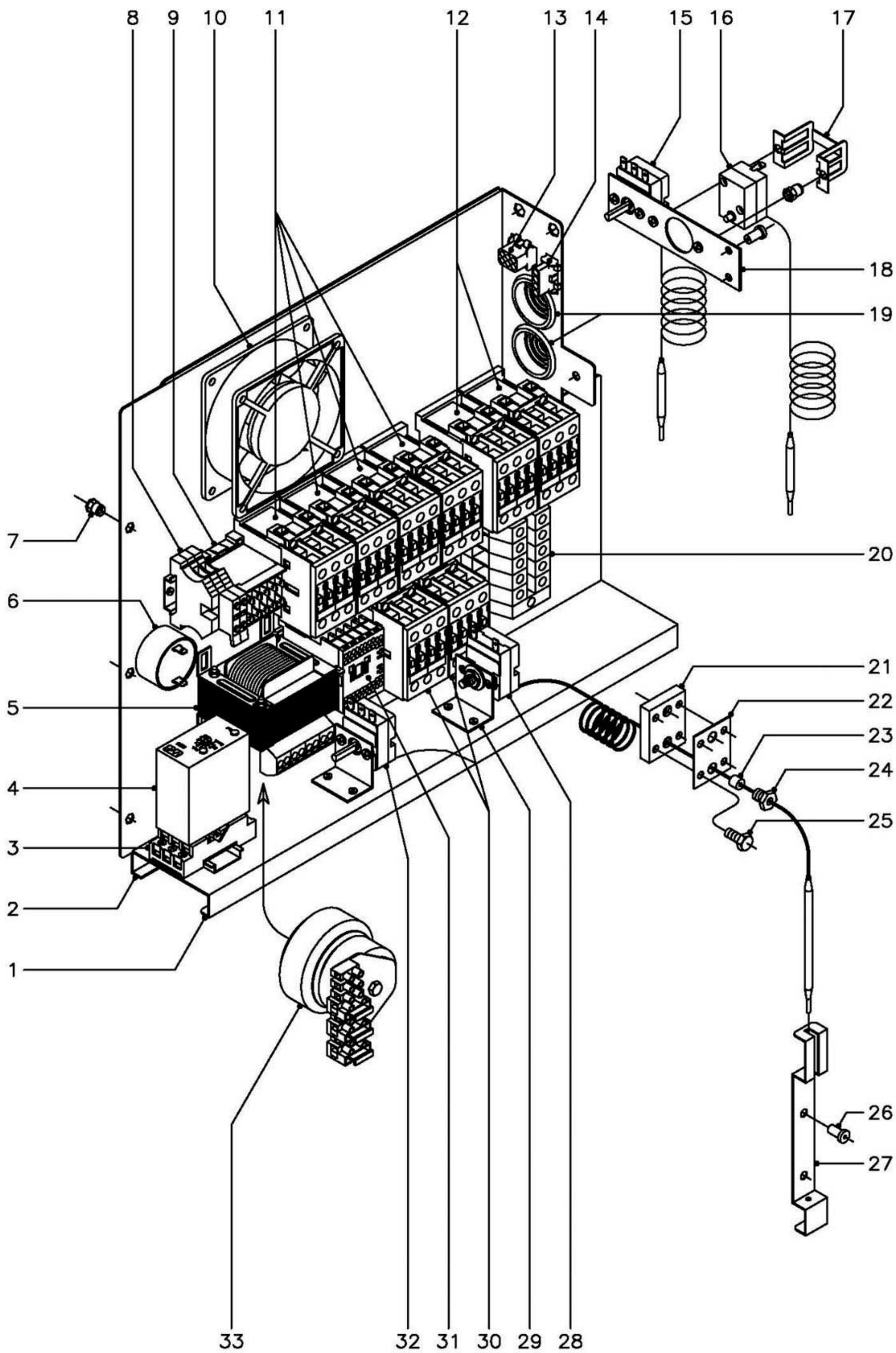

N plano  
C-1476

Firma

Fecha  
11-2003

Aparato

CUADRO ELECTRICO  
HORNOS HMM-20/21

Lamina  
8

Fagor Industrial S.Coop. **FAGOR**  
Oñate



MOD.

HORNOS : HMM-20/21

ZONA

CUADRO ELECTRICO

PLANO

C-1476

ITEM	CODIGO	DENOMINACION	TEXTO	HMM-20/21	HMM-2-20/11	HMM-20/21UL													NOTAS
1	R143001	Panel cuadro electrico		1	1														
2	R663018	Contra guia panel cuadro		1	1														
	Q412002	Remache tubular Ø4x7,5		7	7														
3	R743009	Base enchufable		1	1														
	Z123018	Guia contactor L=55		1	1														
4	R343072	Detector de niveles		1	-														
4	R743031	Detector de niveles		-	1														
5	R503005	Transformador		1	1														
6	R693067	Zumbador		1	1														
7	Q221342	Remache exagonal M-5		3	3														
8	R073005	Bornas portafusibles		2	2														
	P184011	Cartucho fusible 4 A.		2	2														
	Z263303	Tope final		1	1														
9	Z683087	Contacto 3TF20 01 - 3AL2 (230 V.)		1	1														
	Z263303	Tope final		1	1														
10	Z103066	Ventilador		1	1														
11	X183011	Contacto 3RT-1024-1AN20 230V.		4	4														
	R693009	Guia contactor L=250		1	1														
12	X183011	Contacto 3RT-1024-1AN20 230V.		2	2														
	Z403016	Guia contactor L=100		1	1														
13	-	Conector hembra 6 vias		1	1														
14	-	Conector hembra 4 vias		1	1														
15	R343100	Termostato de condensacion		1	1														
	Q153111	Tornillo alomado M-4x8		2	2														
16	Z213014	Termostato Tecasa de seguridad		1	1														
17	Z203060	Amarre limitador Tecasa		1	1														
	Q221341	Remache exagonal M-4		2	2														
	Q153111	Tornillo alomado M-4x8		2	2														
18	R673061	Soporte amarre termostatos		1	1														

MOD.

HORNOS : HMM-20/21

ZONA

CUADRO ELECTRICO

PLANO

C-1476

ITEM	CODIGO	DENOMINACION	TEXTO	HMM-20/21	HMM-2-20/11	HMM-20/21UL												NOTAS
	Q412002	Remache tubular Ø4x7,5		2		2												
19	N103013	Pasacables		2		2												
20	R143011	Borne gris fases 70		3		3												
	R143012	Borne azul neutro 70		1		1												
	Z103035	Borne verde-amarillo tierra 35		1		1												
	Z683096	Tope final 35		1		1												
	Z683068	Señalización bornes		1		1												
	R663055	Guia contactor 120		1		1												
21	R662659	Pasamuros doble para sonda		1		1												
22	R692811	Junta pasamuros doble		1		1												
23	R662662	Junta cierre bulbo limitador		1		1												
24	R662629	Racord cierre sonda		1		1												
25	Q012021	Tornillo exagonal M-4x10		4		4												
26	Q412002	Remache tubular Ø4x7,5		2		2												
27	R662630	Soporte de bulbo		1		1												
28	R243016	Termostato limitador temperatura		1		1												
29	R343039	Soporte de termostatos		2		2												
30	X183011	Contactador 3RT-1024-1AN20 230V.		2		2												
31	Z203050	Contactador sirius 3RT-1016-2AP01		1		1												
	Z123019	Guia contactor 175		1		1												
32	R343018	Termostato a tubo retorno vapor		1		1												
33	R723063	Transformador UL		-		1												

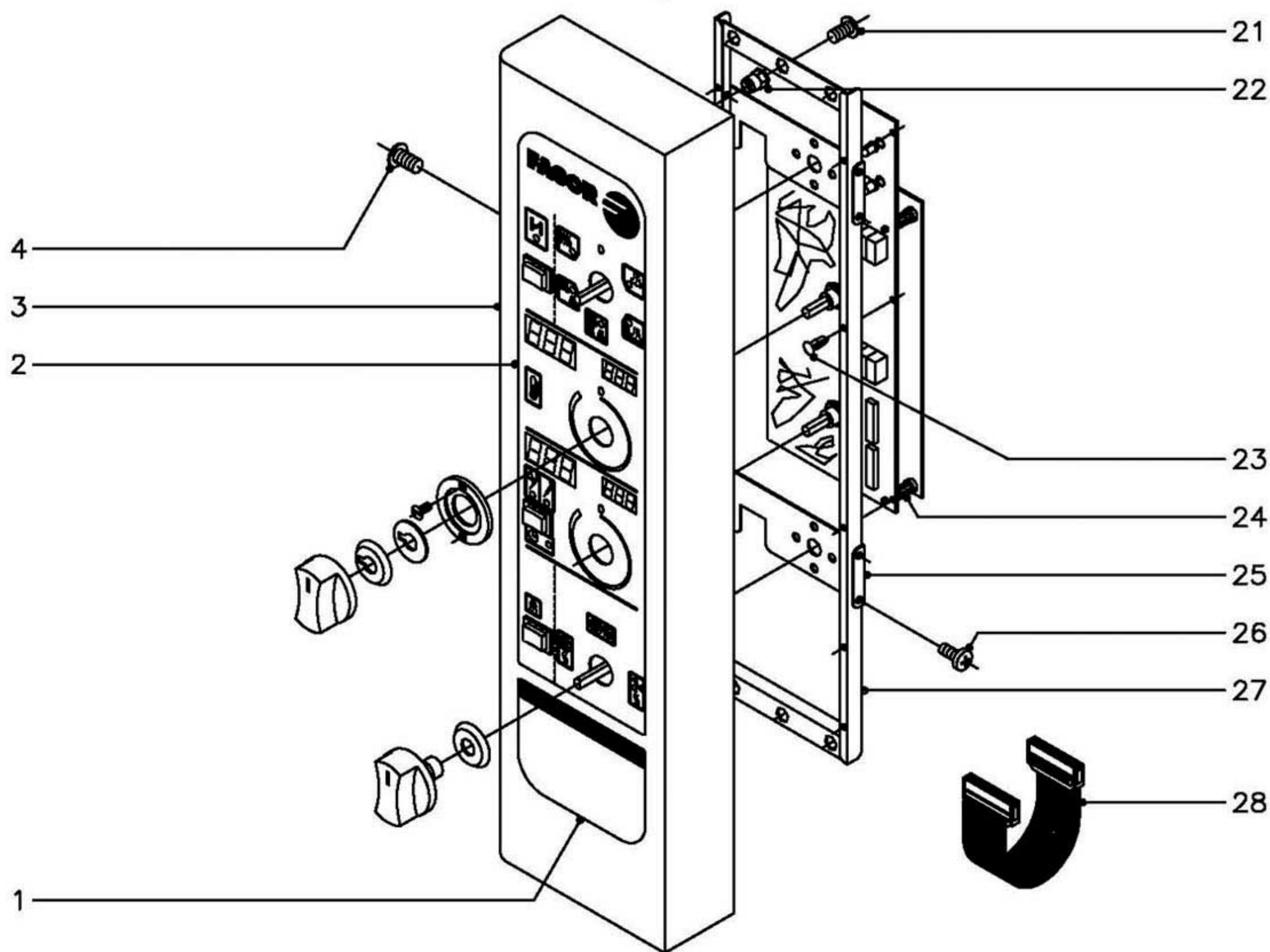
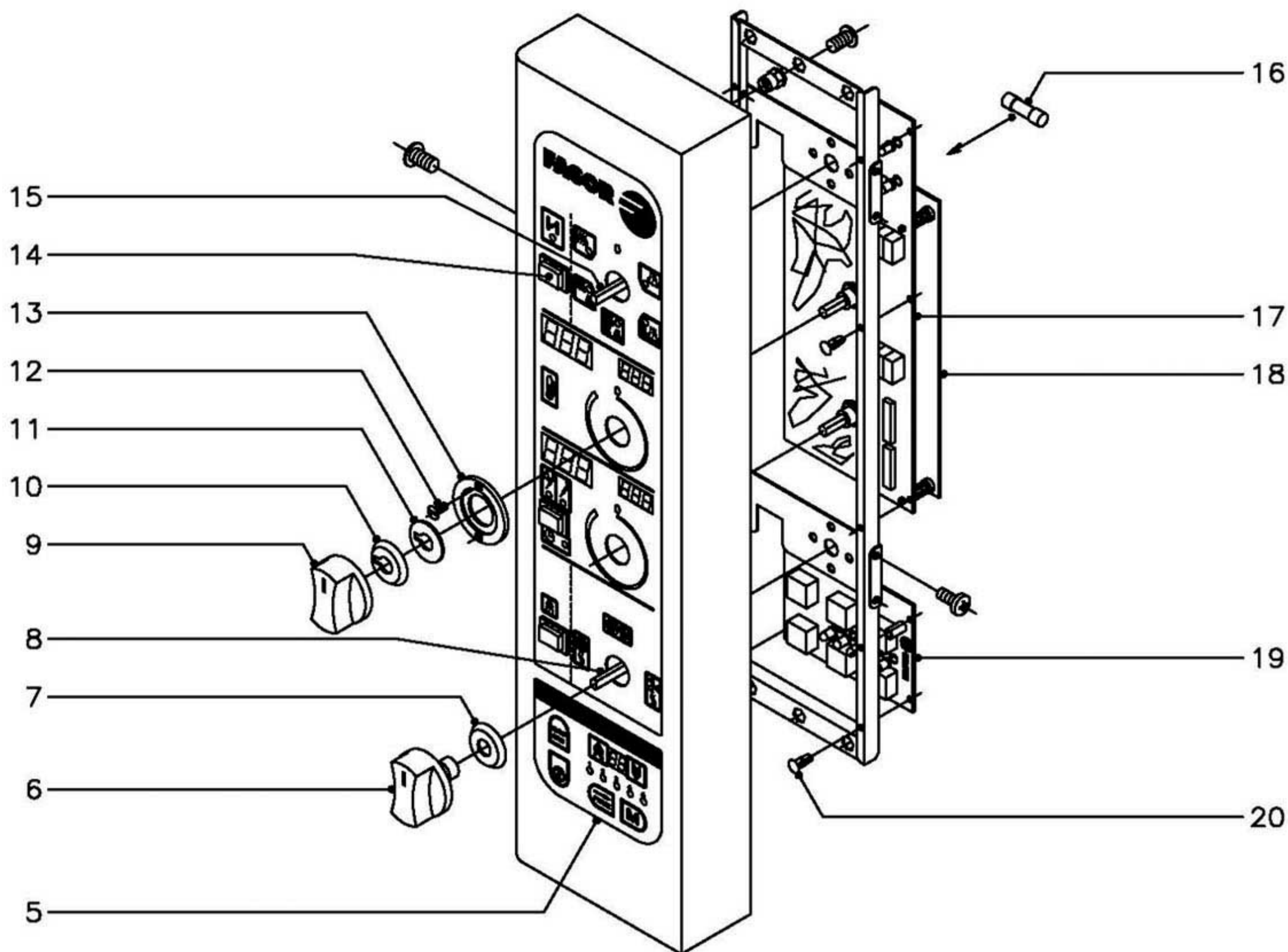

N plano  
C-1477

Firma

Fecha  
11-2003

Aparato SISTEMA ELECTRICO PORTAMANDOS  
HORNOS HME, HMP-20/21

Lamina  
9

Fagor Industrial S.Coop. **FAGOR**  
Orate



MOD.

HORNOS : HME, HMP-20/21

ZONA

SISTEMA ELECTRICO PORTAMANDOS

PLANO

C-1477

ITEM	CODIGO	DENOMINACION	TEXTO	HME-20/21	HME-2-20/11	HMP-20/21	HMP-2-20/11												NOTAS
1	R663014	Serigrafia inferior (neutra)		1	-														
2	R673000	Serigrafia superior (controlador)		1	1														
3	R092837	Panel portamandos		1	1														
4	Q152004	Tornillo aplastado M-5x13		3	3														
5	R663010	Serigrafia inferior (programador)		-	1														
6	R663062	Boton de mando (conmutadores)		2	2														
7	R663046	Junta (conmutadores)		2	2														
8	R663026	Conmutador de funciones		1	1														
9	R663063	Boton de mando (electronica)		2	2														
10	R663045	Junta (circuito impreso)		2	2														
11	R662810	Arandela guia		2	2														
12	Q151346	Tornillo avellanado M-3x5		4	4														
13	R662809	Guia boton de mando		2	2														
14	R663032	Pulsador		3	3														
15	R663025	Conmutador de funciones		1	1														
16	R663101	Fusible 1 A.		1	1														
17	R663050	Circuito impreso mando		1	1														
18	R663085	Circuito impreso control		1	1														
19	R663004	Circuito impreso programador		-	1														
20	R663036	Remache fijacion circuito		-	4														
21	Q152004	Tornillo aplastado M-5x13		2	2														
22	Q221342	Remache exagonal M-5		2	2														
23	R663036	Remache fijacion circuito		6	6														
24	R663035	Separador		4	4														
25	R663008	Soporte conmutadores		2	2														
26	Q151320	Tornillo alomado M-4x6		8	8														
27	R663005	Soporte circuitos impresos		1	1														
28	R663102	Conector de circuitos		1	1														

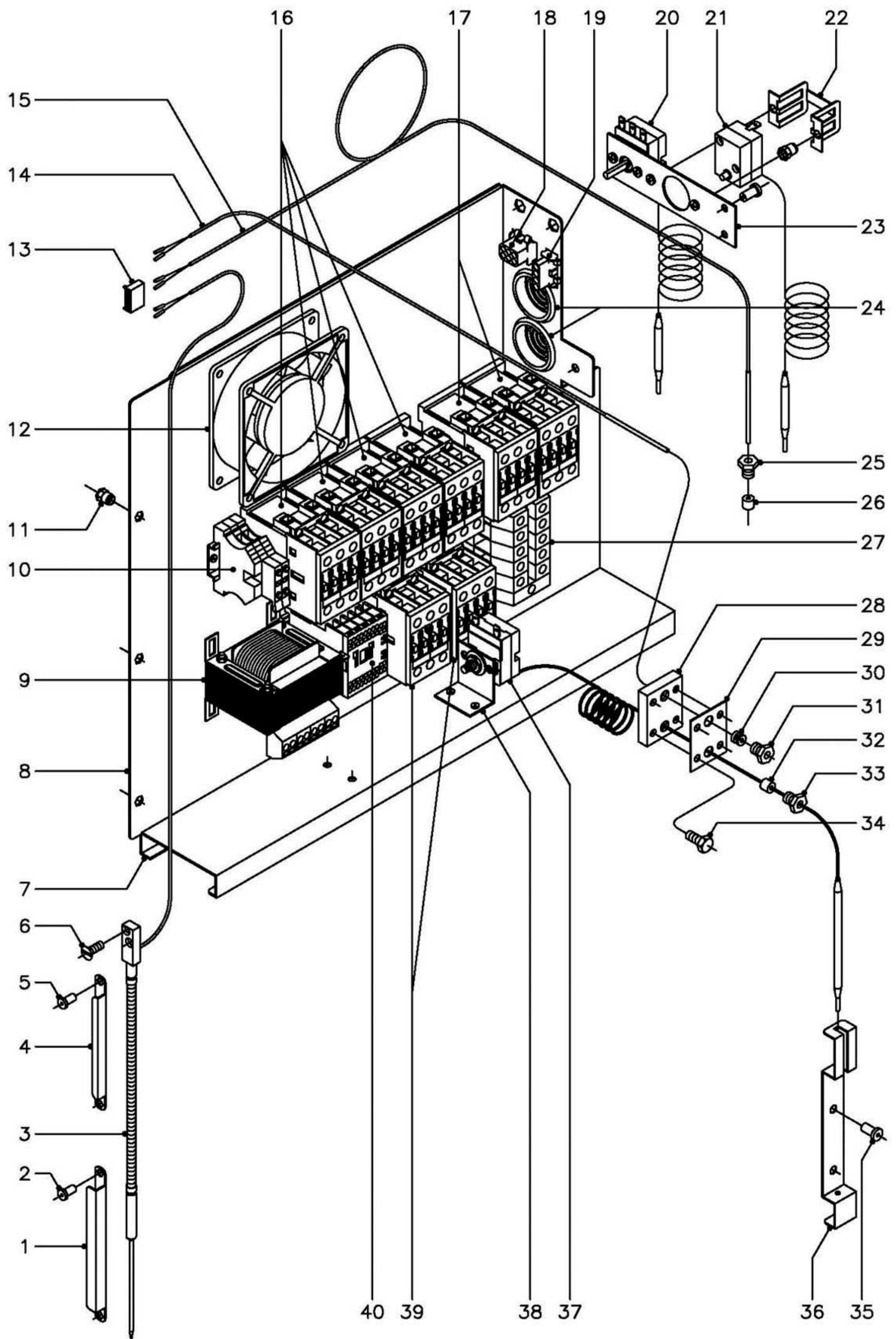

N plano  
C-1478

Firma

Fecha  
11-2003

Aparato  
CUADRO ELECTRICO  
HORNOS HME, HMP-20/21

Lamina  
10

Fagor Industrial S.Coop. **FAGOR**  
Oñate



MOD.

HORNOS : HME, HMP-20/21

ZONA

CUADRO ELECTRICO

PLANO

C-1478

ITEM	CODIGO	DENOMINACION	TEXTO	HME-20/21	HME-2-20/11	HMP-20/21	HMP-2-20/11									NOTAS
1	R672643	Soporte de sonda		1		1										
2	Q412002	Remache tubular Ø4x7,5		2		2										
3	R093019	Conjunto sonda nucleo		1		1										
4	R092633	Retenedor de sonda		2		2										
5	Q412002	Remache tubular Ø4x7,5		2		2										
6	Q042022	Tornillo avellanado M-4x15		2		2										
7	R663018	Contra guía panel cuadro		1		1										
	Q412002	Remache tubular Ø4x7,5		7		7										
8	R143001	Panel cuadro electrico		1		1										
9	R503005	Transformador		1		1										
10	R073005	Bornas portafusibles		2		2										
	P184011	Cartucho fusible 4 A.		2		2										
	Z263303	Tope final		1		1										
11	Q221342	Remache exagonal M-5		3		3										
12	Z103066	Ventilador		1		1										
13	R663093	Conector 6 vias		1		1										
14	R663090	Conjunto termopar L=1500		1		1										
15	R663089	Conjunto termopar L=2500		1		1										
16	X183011	Contactador 3RT-1024-1AN20 230V.		4		4										
	R693009	Guia contactor L=250		1		1										
17	X183011	Contactador 3RT-1024-1AN20 230V.		2		2										
	Z403016	Guia contactor L=100		1		1										
18	-	Conector hembra 6vias		1		1										
19	-	Conector hembra 4vias		1		1										
20	R343100	Termostato de condensacion		1		1										
	Q153111	Tornillo alomado M-4x8		2		2										
21	Z213014	Termostato Tecasa de seguridad		1		1										
22	Z203060	Amarre limitador Tecasa		1		1										
	Q221341	Remache exagonal M-4		2		2										



MOD.

HORNOS : HME, HMP-20/21

ZONA

CUADRO ELECTRICO

PLANO

C-1478

ITEM	CODIGO	DENOMINACION	TEXTO	HME-20/21	HME-2-20/11	HMP-20/21	HMP-2-20/11											NOTAS
	Q153111	Tornillo alomado M-4x8		2		2												
23	R673061	Soporte amarre termostatos		1		1												
	Q412002	Remache tubular Ø4x7,5		2		2												
24	N103013	Pasacables		2		2												
25	R662629	Racord cierre sonda		1		1												
26	3712400	tubo-junta de silicona Ø8xØ3x20		1		1												
27	R143011	Borne gris fases 70		3		3												
	R143012	Borne azul neutro 70		1		1												
	Z103035	Borne verde-amarillo tierra 35		1		1												
	Z683096	Tope final 35		1		1												
	Z683068	Señalización bornes		1		1												
	R663055	Guia contactor 120		1		1												
28	R662659	Pasamuros doble para sonda		1		1												
29	R692811	Junta pasamuros doble		1		1												
30	R662652	Bicono cierre sonda		1		1												
31	R662629	Racord cierre sonda		1		1												
32	R662662	Junta cierre bulbo limitador		1		1												
33	R662629	Racord cierre sonda		1		1												
34	Q012021	Tornillo exagonal M-4x10		4		4												
35	Q412002	Remache tubular Ø4x7,5		2		2												
36	R662630	Soporte de bulbo		1		1												
37	R243016	Termostato limitador temperatura		1		1												
38	R343039	Soporte de termostatos		1		1												
39	X183011	Contactador 3RT-1024-1AN20 230V.		2		2												
40	Z203050	Contactador sirius 3RT-1016-2AP01		1		1												
	Z123019	Guia contactor 175		1		1												

MOD.	HORNOS : HMM, HME, HMP-20/21	ZONA	VARIOS							PLANO	
------	------------------------------	------	--------	--	--	--	--	--	--	-------	--

ITEM	CODIGO	DENOMINACION	TEXTO	HMM-20/21	HMM-2-20/11	HME-20/21	HME-2-20/11	HMP-20/21	HMP-2-20/11	HMM-20/21UL							NOTAS
	R746501	Folleto de instrucciones		1	-	-	-	-	-	-							
	R666501	Folleto de instrucciones		-	1	1	-	-	-	-							
	R696516	Folleto de instrucciones		-	-	-	-	1	-	-							
	R503003	Esquema electrico adhesivo		1	-	-	-	-	-	-							Plano HC-72273
	R143019	Esquema electrico adhesivo		-	1	1	-	-	-	-							Plano HC-74199
	R753025	Esquema electrico adhesivo		-	-	-	-	1	-	-							Plano HC-74750
	R503004	Esquema electrico de montaje		1	-	-	-	1	-	-							Plano HD-12493
	R143018	Esquema electrico de montaje		-	1	1	-	-	-	-							Plano HD-12681
	R503009	Instalacion electrica HMM		1	-	-	-	-	-	-							
	R143017	Instalacion electrica HME, HMP		-	1	1	-	-	-	-							
	R503008	Instalacion electrica HMM, ( UL )		-	-	-	-	1	-	-							
	R143005	Cableado fuerza conveccion		2	2	2	-	-	-	-							
	R143015	Cableado fuerza conveccion		-	-	-	-	2	-	-							
	R503000	Instalacion fuerza cuadro electrico		1	1	1	-	-	-	-							
	R503006	Instalacion fuerza cuadro electrico		-	-	-	-	1	-	-							
	R663095	Cableado luz interior		1	1	1	1	1	-	-							
	R093021	Cableado luz puerta		1	1	1	-	-	-	-							
	R093011	Cableado luz puerta		-	-	-	-	1	-	-							
	R093004	Cable auxiliar prolongador		2	2	2	-	-	-	-							
	R093012	Cable auxiliar prolongador		-	-	-	-	2	-	-							
	3713900	Funda roja-negra Ø6,4x500		1	1	1	1	1	-	-							
	R143004	Cableado fuerza vapor		2	2	2	-	-	-	-							
	R143014	Cableado fuerza vapor		-	-	-	-	2	-	-							
	R143009	Instalacion doble potencia		1	1	1	-	-	-	-							
	R143016	Instalacion doble potencia		-	-	-	-	1	-	-							

MOD.

HORNOS : HMM, HME, HMP-20/21

ZONA

VARIOS

PLANO

ITEM	CODIGO	DENOMINACION	TEXTO	HMM-20/21	HMM-2-20/11	HME-20/21	HME-2-20/11	HMP-20/21	HMP-2-20/11	HMM-20/21UL									NOTAS
	T133001	Cableado conexión dos motores		1		1		1		-									
	T133035	Cableado conexión dos motores		-		-		-		1									
	R663041	Conexión controlador programador		-		-		1		-									
	R703014	Indicador cambio de tension		1		1		1		-									
	R693008	Indicador cambio de tension		-		-		-		1									
	R696504	Etiqueta de sanidad		-		-		-		1									
	R696506	Etiqueta puerta caliente		-		-		-		1									
	R696507	Etiqueta de precaucion		-		-		-		2									
	R696508	Etiqueta de fusibles		-		-		-		1									
	R696512	Etiqueta de conexión		-		-		-		1									
	R746502	Etiqueta descalcificacion		-		-		-		1									
	Z400515	Bisagra (Amarre a pared)		-		-		-		1									



MOD.

HORNOS : HME, HMP-20/21

ZONA

MODIFICACIONES A REALIZAR PARA LA VERSION ( 220/240 V., 3 )

PLANO

C-1473

ITEM	CODIGO	DENOMINACION	TEXTO	HME-20/21	HME-2-20/11	HMP-20/21	HMP-2-20/11										NOTAS
		<b><u>PIEZAS A ELIMINAR</u></b>															
3	R663033	Conj. motor ( 380/400 V., 50/60 Hz.)		1		1											
		<b><u>PIEZAS A INTRODUCIR</u></b>															
3	R663034	Conj. motor ( 220/240 V., 50/60 Hz.)		1		1											



3N~50/60Hz 380/415V

MODELO HMM-20/11 HMM-20/21

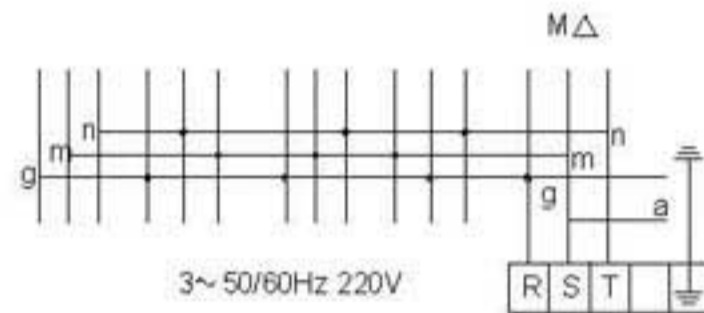
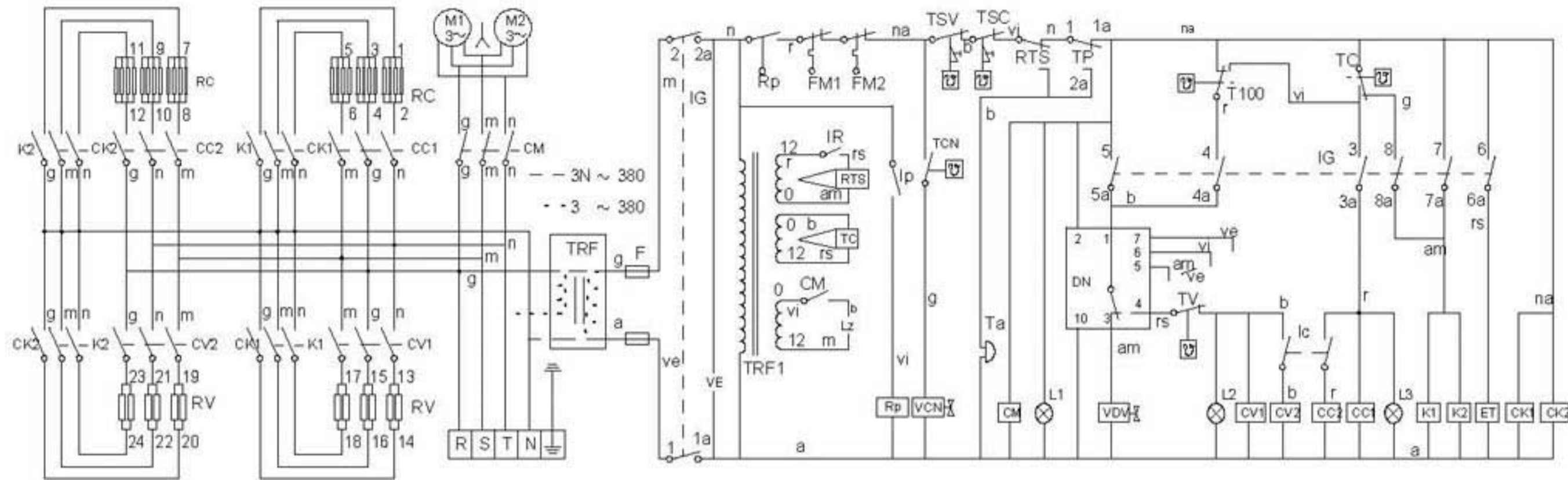

am/ve = amarillo/verde-yellow/green-jaune/vert  
 am = amarillo-yellow-jaune  
 a = azul-blue-bleu  
 b = blanco-white-blanc  
 g = gris-grey-gris  
 ve = verde-green-vert

na = naranja-orange-orange  
 r = rojo-red-rouge  
 m = marron-brown-marron  
 n = negro-black-noir  
 rs = rosa-pink-rose  
 vi = violeta-violet-violette

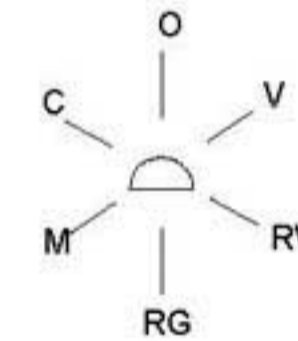

Mode	1 1a	2 2a	3 3a	4 4a-5a	5-6-7 6a-7a-8a	8
OFF						
VAPOR	X	X			X	X
Reg Vapor	X	X		X		X
REGENERAC.	X	X	X	X		X
MIXTO	X	X	X	X		
CONVECCION	X	X	X		X	X

R-503003 HC-72273

IP = Interruptor puerta  
 IG = Interruptor general  
 F = Fusible  
 CM = Contactor motor  
 VDV = Electroválvula calderin  
 DN = Detector de nivel  
 FM1, FM2 = Térmico motor  
 TSV = Termostato seguridad vapor  
 TSC = Termostato seguridad cámara  
 LZ = Luz interior  
 IR = Selector regulador sonda nucleo  
 RTS = Regulador temperatura sonda nucleo  
 RV = Resistencias vapor  
 VE = Ventilador cuadro eléctrico  
 Ta = Timbre avisador  
 RP = Relé puerta

ET = Electroimán de apertura de tiro  
 Ic = Selector de potencia  
 VCN = Electroválvula de condensación de vapor  
 TC = Termostato cámara  
 T100 = Termostato fijo 100°C  
 TV = Termostato vapor  
 M1, M2 = Motor  
 CC1, CC2 = Contactor resistencia cámara  
 CV1, CV2 = Contactor resistencia vapor  
 CK1, CK2, K1, K2 = Relé resistencias  
 TCN = Termostato de condensación vapor  
 RC = Resistencias cámara  
 TRF, TRF1 = Transformador  
 L1 = Lámpara de funcionamiento  
 L2 = Lámpara de calentamiento vapor  
 L3 = Lámpara de calentamiento cámara

ESQUEMA TEORICO ADHESIVO				R-503003	
Nº	Pieza	Cant.	Material	NP Clasificacion	Acabado
Nº	Modificacion		Propuesta de	Fecha	Tolerancias generales
1	Modificar TSV, TSC y TCN		Maillo	2/10/96	<5± : 50-100± : 5-25± : > 100± 25-50± : CX±
2	Modif. general (pasar a fabric. interior)		Plazaola	29/4/97	
3	Eliminar filtro interferencias		Maillo	25/4/98	
4	Introducir Rp		Maillo	25/2/02	
Dibujado		Firma	Fecha	Mecanizado superficial	
Proyectado					
Comprobado					
Escala		<b>HORNO MIXTO HMM</b>			Plano numero
					<b>HC-72273 -4</b>
					Sustituye al N°
					Sustituido por

Plano hau ez daiteke erabili ez berrizta gure baimenitz gabe



3N-50/60Hz 380/415V

MODELO HME-20/11 HMP-20/11

HME-20/21 HMP-20/21

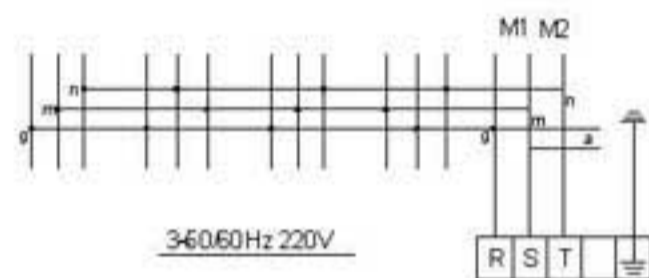
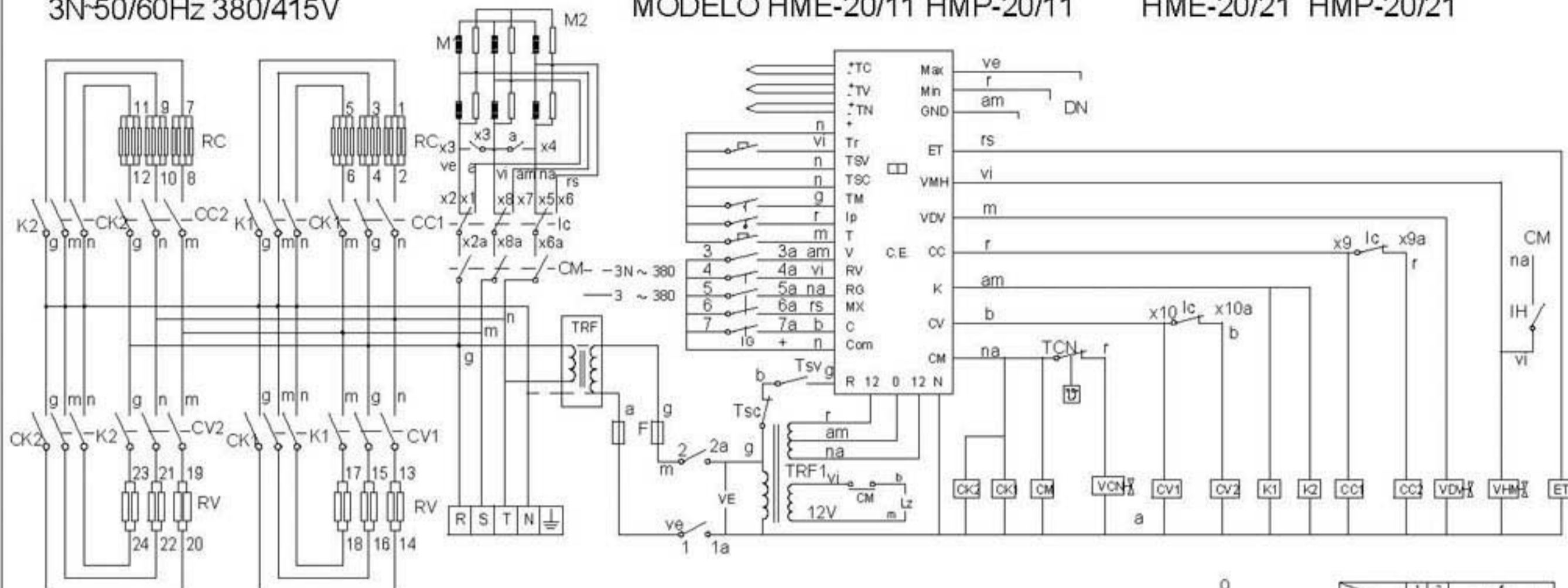

- IP = Door's switch
  - IG = General switch
  - F = Fuse
  - CM = Motor's relay
  - VDV = Steamer's solenoid
  - DN = Water level control
  - TM = Motor's thermal protection
  - TSV = Steamer's security thermostat
  - TSC = Convection's security thermostat
  - LZ = Indoor light
  - VHM = Humidify water solenoid
  - CE = Electronic main control
  - RV = Steamer elements
  - VE = Control panel's fan
  - Tr = Chimney selector
- TRF, TRF1 = Transformer
  - ET = Chimney solenoid
  - Ic = Power reduction switch
  - VCN = Steamer condenser solenoid
  - TV = Steam probe
  - TC = Convection probe
  - TN = Food probe
  - M1, M2 = Motor
  - CC1, CC2 = Heating air relays
  - CV1, CV2 = Heating water relays
  - CK1, CK2, K1, K2 = Elements relays
  - TCN = Steam condenser thermostat
  - IH = Humidify switch
  - T = Timer or Food probe selector
  - RC = Heating element

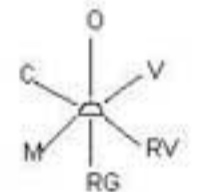

Mode	1	2	3	4	5	6	7
OFF							
VAPOR	X	X	X				
REC-VAPOR	X	X		X			
REGEN BRAC	X	X			X		
MIXTO	X	X				X	
COMBICEDN	X	X					X

Mode	x1	x2	x3	x4	x5	x6	x7	x8	x9	x10
MAX										
MIN										
+	X	X	X	X	X	X	X	X	X	X
-	X	X	X	X	X	X	X	X	X	X
SS		X								

- am/ve = amarillo/verde-yellow/green-jaune/vert
- an = amarillo-yellow-jaune
- a = azul-blue-bleu
- b = blanco-white-blanc
- g = gris grey-gris
- ve = verde-green-vert
- na = naranja-orange-orange
- r = rojo-red-rouge
- m = marron-brown-marron
- n = negro-black-noir
- rs = rosa-pink-rose
- vi = violeta-violet-violette

R-143019

HC-74199

		3~50/60Hz 220V			
<b>ESQUEMA TEORICO ADHESIVO</b>		3N-50/60Hz 380/415V		R-143019	
Nº	Pieza	Cant.	Material	Nº Clasificación	Acabado
Nº	Modificación	Propuesta de		Fecha	Tolerancias generales
					<5± : 50-100± ; 5-25± : >100± ; 25-50± : ∞±
Dibujado		Firma		Fecha	
Proyectado		Irabxe		17/3/99	
Comprobado		FAGOR Fagor Industrial, Koop. Elk. Mugatua		Mecanizado superficial	
Escala				Plano numero <b>HC-74199</b>	
Horno mixto HME HMP Sustituye al Nº hc-72270 Sustituido por					

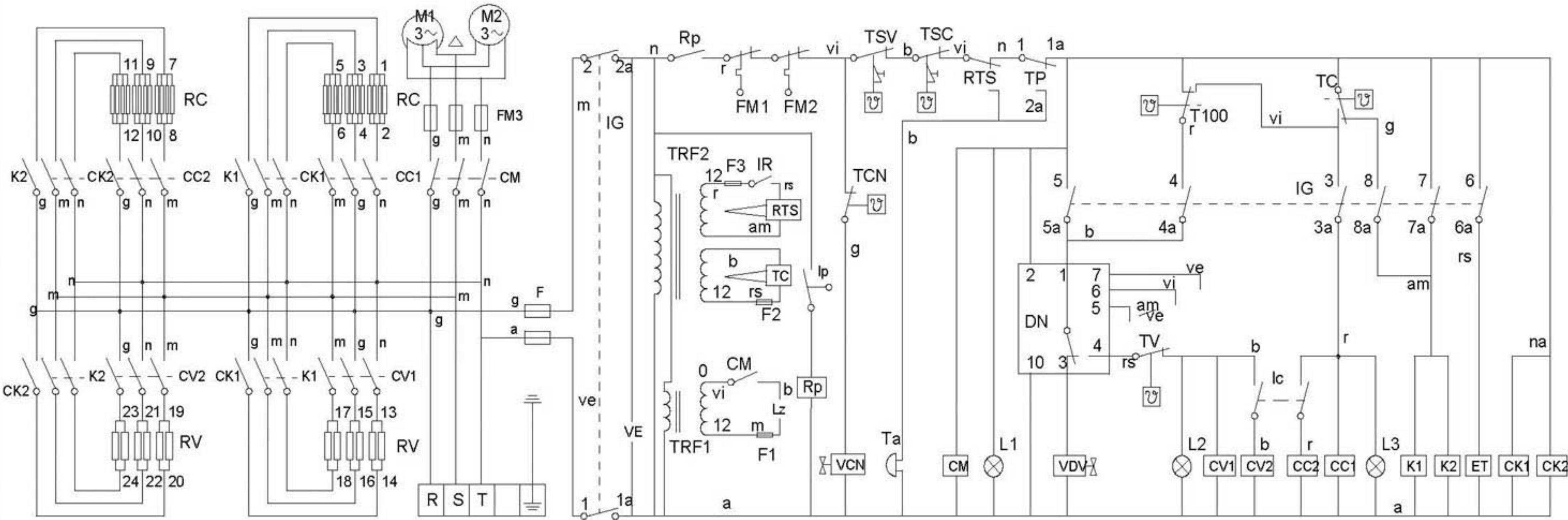

- FM3 = Motor fuse
- IP = Door's switch
- IG = General switch
- F = Fuse
- CM = Motor's relay
- VDV = Steamer's solenoid
- DN = Water level control
- FM1, FM2 = Motor's thermal protection
- TSV = Steamer's security thermostat
- TSC = Convection's security thermostat
- LZ = Indoor light
- IR = Probe selector
- RTS = Probe controller
- RV = Steamer elements

- ET = Chimney solenoid
- Ic = Power reduction switch
- VCN = Steamer condenser solenoid
- TC = Convection thermostat
- T100 = 100 °C thermostat
- TV = Steamer's thermostat
- M1, M2 = Motor
- CC1, CC2 = Heating air relays
- CV1, CV2 = Heating water relays
- CK1, CK2, K1, K2 = Elements relays
- TCN = Steam condenser thermostat
- RC = Heating element
- TRF2 = Transformer (Electronic thermostat)

- VE = Control panel's fan
- Ta = Alarm
- Tp = Manual Timer
- F1, F2, F3 = Transformer fuse
- TRF1 = Transformer (Indoor light)
- L1 = Pilot lamp (on/off)
- L2 = Pilot lamp (Heating water)
- L3 = Pilot lamp (Heating air)
- Rp = Door's relay

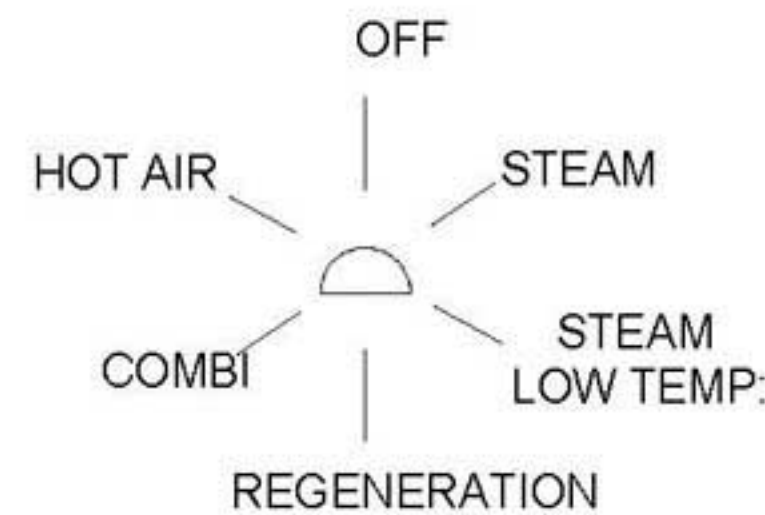

- am/ve = amarillo/verde-yellow/green-jaune/vert
- am = amarillo-yellow-jaune
- a = azul-blue-bleu
- b = blanco-white-blanc
- g = gris-grey -gris
- ve = verde-green-vert

- na = naranja-orange-orange
- r = rojo-red-rouge
- m = marron-brown-marron
- n = negro-black-noir
- rs = rosa-pink-rose
- vi = violeta-violet-violette

Mode \	1 1a	2 2a	3 3a	4 4a	5-6 5a-6a	7-8 7a-8a
OFF						
STEAM	X	X			X	X
STEAM LOW TEMP	X	X		X		X
REGENERATION	X	X	X	X		X
COMBI	X	X	X	X		
HOT AIR	X	X	X		X	X







