

**Hornos Mixtos
Fours Mixtes
Combi Ovens
HeiBluftdämpfer
Forno Misti**

Modelos:

HMM-6/11

HMM-10/11

HMM-10/21

HMM-2-10/11

MFHMM-6/11

MFHMM-10/11

MFHMM-10/21

HMM-6/11 UL

HMM-10/11 UL

HMM-10/21 UL

VECM-6/11

VECM-10/11

VECM-10/21

VECM-2-10/11

Noviembre 2003 November

FAGOR



Fagor Industrial

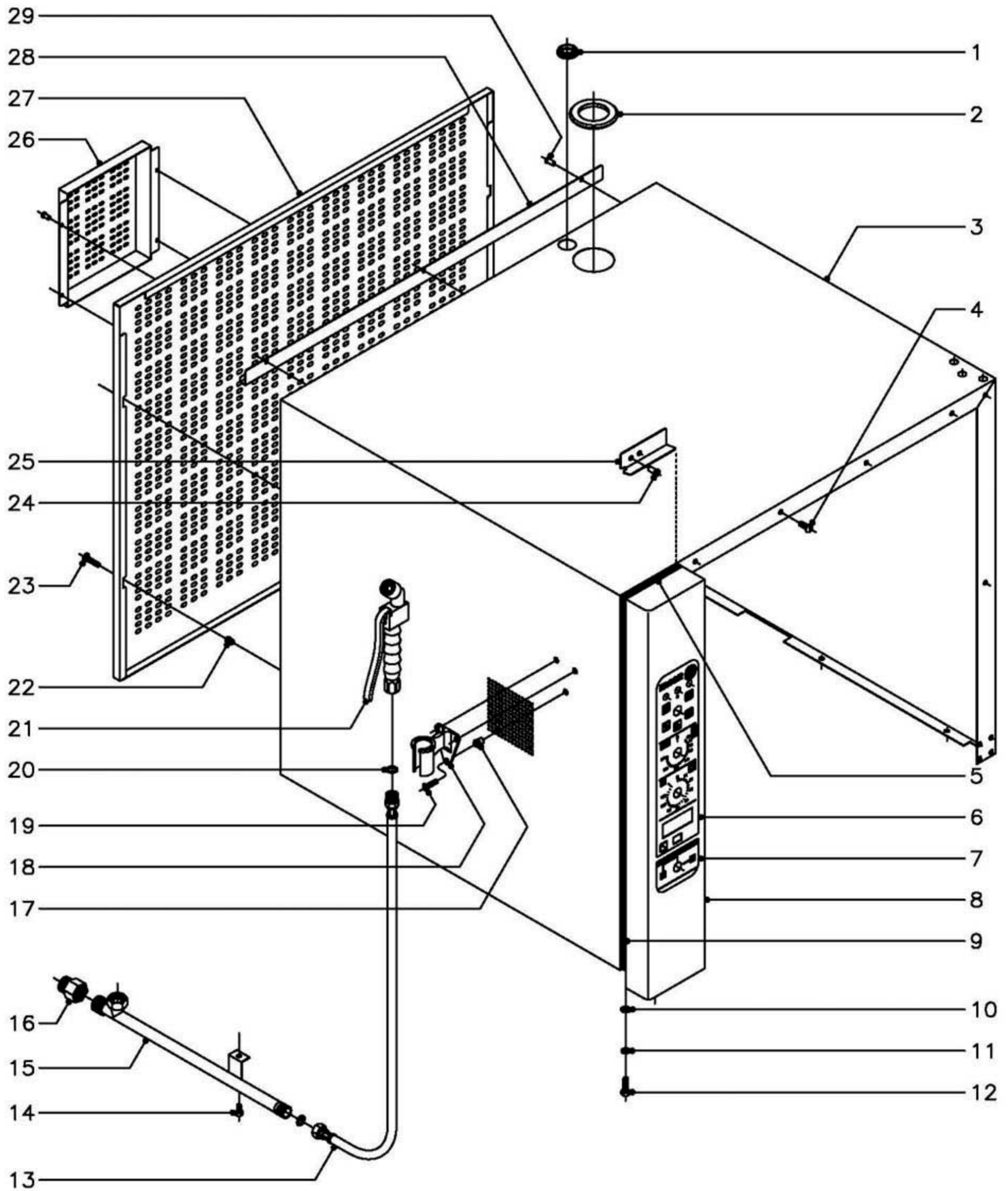

N plano
C-1443

Firma
[Signature]

Fecha
11-2003

Aparato
HORNOS MIX. ELECTROMECHANICOS

MUEBLE

Lamina
1

Fagor Industrial S.Coop. **FAGOR**
Ofata



MOD.

HORNOS MIXTOS ELECTROMECAVICOS

ZONA

MUEBLE

PLANO

C-1443

ITEM	CODIGO	DENOMINACION	TEXTO	HMM-6/11	HMM-10/11	HMM-10/21	HMM-2-10/11	HMM-6/11 UL	HMM-10/11 UL	HMM-10/21 UL		NOTAS
1	N503017	Soporte termostato		1	1	1	1	1	1	1		Pasamuros chimenea
2	R662813	Pasamuros chimenea		1	1	1	1	1	1	1		
3	R662819	Cuerpo exterior de horno 6/11		1	-	-	-	1	-	-		
3	R672816	Cuerpo exterior de horno 10/11		-	1	-	-	-	1	-		
3	R682812	Cuerpo exterior de horno 10/21		-	-	1	1	-	-	1		
4	Q152017	Tornillo amarre M-6x13		6	6	6	6	6	6	6		
5	3715400	Junta panel portamandos L=130		1	1	1	1	1	1	1		
6	R743012	Serigrafia superior (FAGOR)		1	1	1	1	-	-	-		
6	R743070	Serigrafia superior (FAGOR - UL)		-	-	-	-	1	1	1		
6	R743020	Serigrafia superior (MF)		-	-	-	-	1	1	1		
7	R663014	Serigrafia inferior (FAGOR)		1	-	-	-	1	-	-		
7	R693000	Serigrafia inferior (FAGOR)		-	1	1	1	-	1	1		
7	R693057	Serigrafia inferior (MF)		-	-	-	-	1	-	-		
7	R693031	Serigrafia inferior (MF)		-	-	-	-	-	1	1		
8	R742807	Panel portamandos 6/11		1	-	-	-	1	-	-		
8	R752805	Panel portamandos 10/11 y 10/21		-	1	1	1	-	1	1		
9	3715400	Junta panel portamandos L=530		2	-	-	-	2	-	-		
9	3715400	Junta panel portamandos L=770		-	2	2	2	-	2	2		
10	Q232040	Arandela plana A-6		2	2	2	2	2	2	2		
11	Q262040	Arandela muelle A-6		2	2	2	2	2	2	2		
12	Q012042	Tornillo exagonal M-6x15		2	2	2	2	2	2	2		
13	R095006	Flexible de ducha		*	*	*	*	1	1	1		* Opcional bajo pedido
14	Q012042	Tornillo exagonal M-6x15		*	*	*	*	1	1	1		* Opcional bajo pedido
15	R675002	Suplemento ducha		*	*	-	-	1	1	-		* Opcional bajo pedido
15	R685003	Suplemento ducha		-	-	*	*	-	-	1		* Opcional bajo pedido
16	T125033	Adaptador a rosca UL		-	-	-	-	1	1	1		
17	Q221342	Remache exagonal M-4		*	*	*	*	3	3	3		* Opcional bajo pedido
18	R095007	Soporte de ducha		*	*	*	*	1	1	1		* Opcional bajo pedido
19	Q042022	Tornillo avellanado M-4x15		*	*	*	*	3	3	3		* Opcional bajo pedido

MOD.

HORNOS MIXTOS ELECTROMECHANICOS

ZONA

MUEBLE

PLANO

C-1443

ITEM	CODIGO	DENOMINACION	TEXTO	HMM-6/11	HMM-10/11	HMM-10/21	HMM-2-10/11	HMM-6/11 UL	HMM-10/11 UL	HMM-10/21 UL		NOTAS
20	Q306024	Arandela junta Ø18xØ12,5x1,5		*	*	*	*	2	2	2		* Opcional bajo pedido
21	R095005	Cuerpo de ducha		*	*	*	*	1	1	1		* Opcional bajo pedido
22	Q221342	Remache exagonal M-5		4	4	4	4	4	4	4		
23	Q152038	Tornillo amarre M-5x30		4	4	4	4	4	4	4		
24	Q412002	Remache tubular Ø 4x7,5		2	2	2	2	2	2	2		
25	R662811	Fijacion portamandos		1	1	1	1	1	1	1		
26	R092822	Tapa ventilacion motor		1	1	1	1	1	1	1		
	Q412002	Remache tubular Ø 4x7,5		4	4	4	4	4	4	4		
27	R662816	Panel posterior		1	-	-	-	1	-	-		
27	R672812	Panel posterior		-	1	-	-	-	1	-		
27	R682807	Panel posterior		-	-	1	1	-	-	1		
28	R672811	Canaleta recogeaguas		1	1	-	-	1	1	-		
28	R682806	Canaleta recogeaguas		-	-	1	1	-	-	1		
29	Q412002	Remache tubular Ø 4x7,5		3	3	3	3	3	3	3		

N plano
C-1444



Firma

Fecha

11-2003
Aparato
HORNS MIX. ELECTROMECANICOS

PUERTA

Laminas

2

Fagor Industrial S. Coop.
Onate
FAGOR

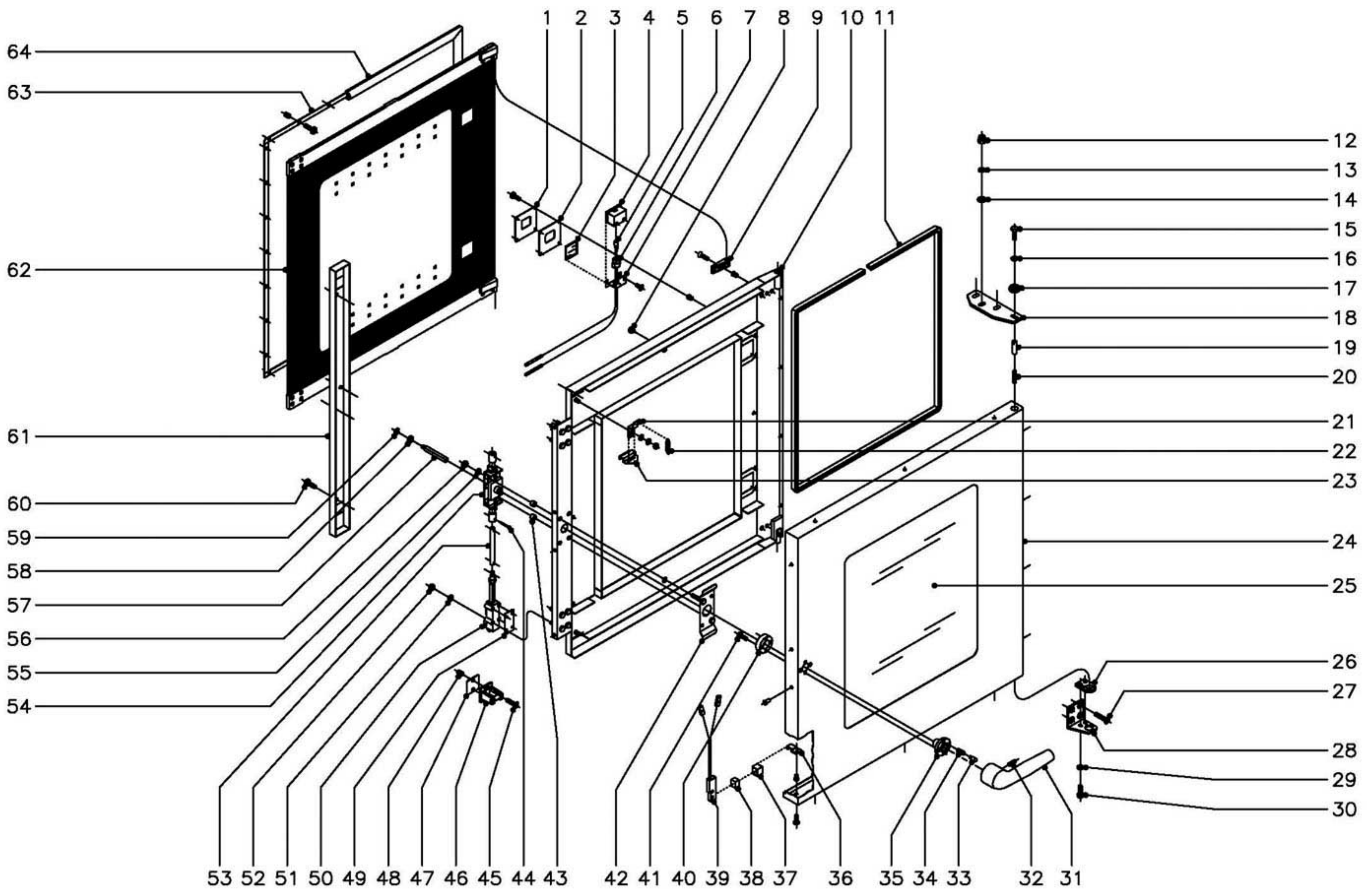

MOD.

HORNOS MIXTOS ELECTROMECAVICOS

ZONA

PUERTA

PLANO

C-1444

ITEM	CODIGO	DENOMINACION	TEXTO	HMM-6/11	HMM-10/11	HMM-10/21	HMM-2-10/11	HMM-6/11 UL	HMM-10/11 UL	HMM-10/21 UL			NOTAS
	1100002594	KIT Puerta completa 6/11		1	-	-	-	1	-	-			
	1100002595	KIT Puerta completa 10/11		-	1	-	-	-	1	-			
	1100002596	KIT Puerta completa 10/21		-	-	1	1	-	-	1			
1	R670608	Tapa cierre lampara		2	2	2	2	2	2	2			
	Q152004	Tornillo aplastado M-5x13		8	8	8	8	8	8	8			
	Q222011	Remache exagonal M-5		8	8	8	8	8	8	8			
2	R670609	Junta cierre lampara		2	2	2	2	2	2	2			
3	R670618	Cristal de lampara		2	2	2	2	2	2	2			
4	R670610	Deflector de lampara		2	2	2	2	2	2	2			
5	R663013	Lampara 10 W. 12 V.		2	2	2	2	2	2	2			
6	R663058	Portalamparas		2	2	2	2	2	2	2			
7	R670611	Suplemento deflector		2	2	2	2	2	2	2			
	Q042031	Tornillo avellanado M-5x10		4	4	4	4	4	4	4			
8	R670617	Tope cristal interior		6	6	6	6	6	6	6			
9	R670615	Base de bisagra		2	2	2	2	2	2	2			
	Q042032	Tornillo avellanado M-5x15		2	2	2	2	2	2	2			
	Q222011	Remache exagonal M-5		2	2	2	2	2	2	2			
10	T080500	Contrapuerta completa 6/11		1	-	-	-	1	-	-			
10	T110500	Contrapuerta completa 10/11		-	1	-	-	-	1	-			
10	T120500	Contrapuerta completa 10/21		-	-	1	1	-	-	1			
11	3715200	Junta cristal L=1700		1	-	-	-	1	-	-			
11	3715200	Junta cristal L=2000		-	1	-	-	-	1	-			
11	3715200	Junta cristal L=2300		-	-	1	1	-	-	1			
12	Q212051	Tuerca sombrerete M-8		3	3	3	3	3	3	3			
13	Q242050	Arandela abanico A-8		3	3	3	3	3	3	3			
14	Q302025	Arandela plana Ø8,4xØ20x1,5		3	3	3	3	3	3	3			
15	Q012042	Tornillo exagonal M-6x15		1	1	1	1	1	1	1			
16	Q242040	Arandela abanico A-6		1	1	1	1	1	1	1			

MOD.

HORNOS MIXTOS ELECTROMECHANICOS

ZONA

PUERTA

PLANO

C-1444

ITEM	CODIGO	DENOMINACION	TEXTO	HMM-6/11	HMM-10/11	HMM-10/21	HMM-2-10/11	HMM-6/11 UL	HMM-10/11 UL	HMM-10/21 UL			NOTAS
17	R662807	Arandela amarre puerta		1	1	1	1	1	1	1			
18	T130500	Bisagra superior		1	1	1	1	1	1	1			
19	R660534	Eje superior		1	1	1	1	1	1	1			
20	Z850519	Resorte		1	1	1	1	1	1	1			
21	R670612	Base de pestillo		2	2	2	2	2	2	2			
	Q302022	Arandela plana Ø16xØ6x1,2		2	2	2	2	2	2	2			
	Q242040	Arandela abanico A-6		2	2	2	2	2	2	2			
	Q162040	Tuerca exagonal M-6		2	2	2	2	2	2	2			
22	R660605	Muelle tensor pestillo		2	2	2	2	2	2	2			
23	R670613	Pestillo sujecion cristal interior		2	2	2	2	2	2	2			
24	R660600	Panel puerta 6/11		1	-	-	-	1	-	-			
24	R670600	Panel puerta 10/11		-	1	-	-	-	1	-			
24	R680600	Panel puerta 10/21		-	-	1	1	-	-	1			
	Q412002	Remache tubular Ø4x7,5		14	14	14	14	14	14	14			
25	R660606	Cristal exterior 6/11		1	-	-	-	1	-	-			
25	R670625	Cristal exterior 10/11		-	1	-	-	-	1	-			
25	R680609	Cristal exterior 10/21		-	-	1	1	-	-	1			
26	R660549	Guia eje inferior		1	1	1	1	1	1	1			
27	Q062040	Tornillo avellanado M-6x16		4	4	4	4	4	4	4			
28	R660551	Bisagra inferior		1	1	1	1	1	1	1			
29	Q242040	Arandela abanico A-6		2	2	2	2	2	2	2			
30	Q012041	Tornillo exagonal M-6x10		2	2	2	2	2	2	2			
31	T130502	Manilla		1	1	1	1	1	1	1			
32	Q132042	Varilla roscada M-6x15		1	1	1	1	1	1	1			
33	T130507	Piton engancho		2	2	2	2	2	2	2			
34	T130506	Resorte		2	2	2	2	2	2	2			
35	T130515	Guia manilla		1	1	1	1	1	1	1			
36	T130513	Soporte iman		1	1	1	1	1	1	1			
37	Z200507	Protector iman		1	1	1	1	1	1	1			

MOD.

HORNOS MIXTOS ELECTROMECAVICOS

ZONA

PUERTA

PLANO

C-1444

ITEM	CODIGO	DENOMINACION	TEXTO	HMM-6/11	HMM-10/11	HMM-10/21	HMM-2-10/11	HMM-6/11 UL	HMM-10/11 UL	HMM-10/21 UL			NOTAS
38	Z200506	Iman		1	1	1	1	1	1	1			
39	Z100522	Interruptor magnetico		1	1	1	1	1	1	1			
40	T130514	Soporte resortes		1	1	1	1	1	1	1			
41	Q032032	Tornillo alomado M-5x15		2	2	2	2	2	2	2			
42	T130511	Suplemento fijacion cerradura		1	1	1	1	1	1	1			
43	Z608410	Casquillo		2	2	2	2	2	2	2			
44	Q352001	Pasador de aletas Ø2x15		4	4	4	4	4	4	4			
45	Q042043	Tornillo avellanado M-6x20		4	4	4	4	4	4	4			
46	R260545	Enganche		2	2	2	2	2	2	2			
47	R660538	Calzo de enganche		4	4	4	4	4	4	4			
48	Q221343	Remache exagonal M-6		4	4	4	4	4	4	4			
49	T080503	Suplemento elemento cierre		6	6	6	6	6	6	6			
50	T080504	Elemento de cierre		2	2	2	2	2	2	2			
51	Q262040	Arandela muelle A-6		8	8	8	8	8	8	8			
52	Q162040	Tuerca exagonal M-6		8	8	8	8	8	8	8			
53	R020502	Tubo alargadera		-	2	2	2	-	2	2			
54	T130509	Mecanismo de cierre		1	1	1	1	1	1	1			
55	Q262040	Arandela muelle A-6		2	2	2	2	2	2	2			
56	Q162040	Tuerca exagonal M-6		2	2	2	2	2	2	2			
57	T130508	Eje de manilla		1	1	1	1	1	1	1			
58	T130505	Casquillo		1	1	1	1	1	1	1			
59	Q271033	Arandela de seguridad Ø6		1	1	1	1	1	1	1			
60	Q032031	Tornillo alomado M-5x10		2	2	2	2	2	2	2			
60	Q032021	Tornillo alomado M-4x10		2	2	2	2	2	2	2			
61	T080502	Tapa cierre puerta		1	-	-	-	1	-	-			
61	T110502	Tapa cierre puerta		-	1	1	1	-	1	1			
62	1100002806	KIT Cristal interior completo 6/11		1	-	-	-	1	-	-			
62	1100002807	KIT Cristal interior completo 10/11		-	1	-	-	-	1	-			
62	1100002808	KIT Cristal interior completo 10/21		-	-	1	1	-	-	1			

MOD.

HORNOS MIXTOS ELECTROMECHANICOS

ZONA

PUERTA

PLANO

C-1444

ITEM	CODIGO	DENOMINACION	TEXTO	HMM-6/11	HMM-10/11	HMM-10/21	HMM-2-10/11	HMM-6/11 UL	HMM-10/11 UL	HMM-10/21 UL			NOTAS
63	R660526	Fijacion junta completa 6/11		1	-	-	-	1	-	-			
63	R670513	Fijacion junta completa 10/11		-	1	-	-	-	1	-			
63	R680511	Fijacion junta completa 10/21		-	-	1	1	-	-	1			
	Q033021	Tornillo alomado M-4x10 (laton)		28	28	28	28	28	28	28			
	Q222041	Remache exagonal M-4 inox.		28	28	28	28	28	28	28			
64	R660503	Junta de puerta 6/11		1	-	-	-	1	-	-			
64	R670500	Junta de puerta 10/11		-	1	-	-	-	1	-			
64	R680500	Junta de puerta 10/21		-	-	1	1	-	-	1			

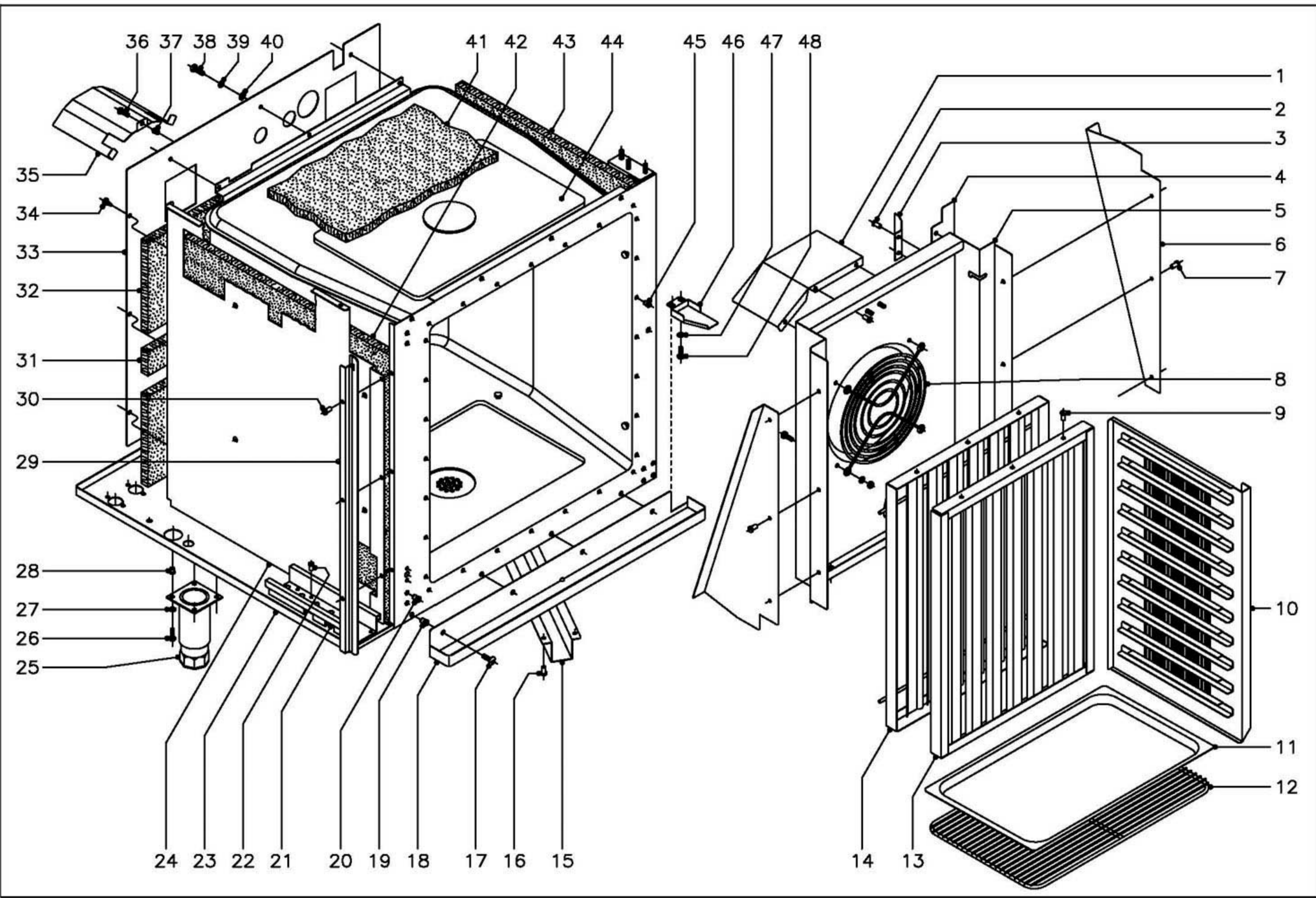

N plano C-1445	Firma 	Fecha 11-2003	Aparato MUEBLE INTERIOR HORNOS MIX. ELECTROMECHANICOS	Lamina 3	Fagor Industrial S.Coop. FAGOR Oñate
-------------------	-----------	------------------	---	-------------	--

MOD.

HORNOS MIXTOS ELECTROMECHANICOS

ZONA

MUEBLE INTERIOR

PLANO

C-1445

ITEM	CODIGO	DENOMINACION	TEXTO	HMM-6/11	HMM-10/11	HMM-10/21	HMM-2-10/11	HMM-6/11 UL	HMM-10/11 UL	HMM-10/21 UL			NOTAS
1	R682632	Deflector de turbina		-	-	2	2	-	-	2			
	Q412002	Remache tubular Ø 4x7,5		-	-	6	6	-	-	6			
2	Q412002	Remache tubular Ø 4x7,5		4	4	4	4	4	4	4			
3	R292647	Escuadra sujecion cubreventilador		2	2	2	2	2	2	2			
4	R662648	Aleron derecho		1	-	-	-	1	-	-			
s/n	R662647	Aleron izquierdo		1	-	-	-	1	-	-			
	Q412002	Remache tubular Ø 4x7,5		6	-	-	-	6	-	-			
5	R662656	Cubre ventilador		1	-	-	-	1	-	-			
5	R672651	Cubre ventilador		-	1	-	-	-	1	-			
5	R682669	Cubre ventilador		-	-	1	1	-	-	1			
6	R732619	Aleron lateral		-	-	2	2	-	-	2			
7	Q412002	Remache tubular Ø 4x7,5		-	-	6	6	-	-	6			
8	R662661	Proteccion de turbina		-	-	-	-	1	1	1			
	Q032021	Tornillo alomado M-4x10		-	-	-	-	4	4	4			
	Q242020	Arandela abanico A-4		-	-	-	-	4	4	4			
	Q162020	Tuerca exagonal M-4		-	-	-	-	4	4	4			
9	Q412002	Remache tubular Ø 4x7,5		6	6	6	6	6	6	6			
10	R662668	Guia de bandejas derecha		1	-	-	-	1	-	-			
s/n	R662670	Guia de bandejas izquierda		1	-	-	-	1	-	-			
10	T112615	Guia de bandejas derecha		-	1	-	-	-	1	-			
s/n	T112617	Guia de bandejas izquierda		-	1	-	-	-	1	-			
10	T122614	Guia de bandejas derecha		-	-	1	-	-	-	-			
s/n	T122616	Guia de bandejas izquierda		-	-	1	-	-	-	-			
10	R682640	Guia de bandejas MARKET-FORGE		-	-	-	-	-	-	2			
11	R252816	Bandeja 1/1 (530x325x20)		1	1	-	1	-	-	-			
11	R032605	Bandeja 2/1 (530x650x40)		-	-	1	-	-	-	-			
12	R672665	Parrilla 1/1		1	1	-	1	3	5	-			
12	R682676	Parrilla 2/1		-	-	1	-	-	-	-			
12	R682641	Parrilla 2/1 MARKET-FORGE		-	-	-	-	-	-	5			

ITEM	CODIGO	DENOMINACION	TEXTO	HMM-6/11	HMM-10/11	HMM-10/21	HMM-2-10/11	HMM-6/11 UL	HMM-10/11 UL	HMM-10/21 UL			NOTAS
13	R662617	Anterior de filtro		1	-	-	-	1	-	-			
13	R092618	Anterior de filtro		-	1	1	1	-	1	1			
14	R662622	Posterior de filtro		1	-	-	-	1	-	-			
14	R092621	Posterior de filtro		-	1	1	1	-	1	1			
15	R672804	Cubre desagüe		1	1	-	-	1	1	-			
15	R682805	Cubre desagüe		-	-	1	1	-	-	1			
16	Q412002	Remache tubular Ø 4x7,5		8	8	8	8	8	8	8			
17	Q152017	Tornillo amarre M-6x13		4	4	4	4	4	4	4			
18	T112813	Recoge aguas		1	1	-	-	1	1	-			
18	T122811	Recoge aguas		-	-	1	1	-	-	1			
19	Q221343	Remache exagonal M-6		4	4	4	4	4	4	4			
20	Q221343	Remache exagonal M-6		8	8	8	8	8	8	8			
21	R342821	Guia del cuadro electrico		1	1	1	1	1	1	1			
22	Q412002	Remache tubular Ø 4x7,5		8	8	8	8	8	8	8			
23	R672813	Base exterior de horno		1	1	-	-	1	1	-			
23	R682811	Base exterior de horno		-	-	1	1	-	-	1			
24	T072614	Soporte lateral aislante		1	-	-	-	1	-	-			
24	T112624	Soporte lateral aislante		-	1	-	-	-	1	-			
24	T122619	Soporte lateral aislante		-	-	1	1	-	-	1			
25	X260151	Pata regulable		4	4	4	4	4	4	4			
26	Q012042	Tornillo exagonal M-6x15		16	16	16	16	16	16	16			
27	Q242040	Arandela abanico A-6		16	16	16	16	16	16	16			
28	Q221343	Remache exagonal M-6		16	16	16	16	16	16	16			
29	R662682	Protector portamandos		1	-	-	-	1	-	-			
29	R672674	Protector portamandos		-	1	1	1	-	1	1			
30	Q412002	Remache tubular Ø 4x7,5		3	3	3	3	3	3	3			
31	R662616	Aislante posterior 560x60x20		3	3	4	4	3	3	4			
32	R662615	Aislante posterior 800x110x20		2	-	-	-	2	-	-			
32	R672631	Aislante posterior 670x230x20		-	2	2	2	-	2	2			

MOD.

HORNOS MIXTOS ELECTROMECHANICOS

ZONA

MUEBLE INTERIOR

PLANO

C-1445

ITEM	CODIGO	DENOMINACION	TEXTO	HMM-6/11	HMM-10/11	HMM-10/21	HMM-2-10/11	HMM-6/11 UL	HMM-10/11 UL	HMM-10/21 UL			NOTAS
33	R662655	Soporte aislante posterior		1	-	-	-	1	-	-			
33	R672608	Soporte aislante posterior		-	1	-	-	-	1	-			
33	R682606	Soporte aislante posterior		-	-	1	1	-	-	1			
34	Q151301	Tornillo alomado		3	3	3	3	3	3	3			
35	R142628	Tejadillo motor turbina		1	1	1	1	1	1	1			
36	Q012042	Tornillo exagonal M-6x15		1	1	1	1	1	1	1			
37	Q221343	Remache exagonal M-6		1	1	1	1	1	1	1			
38	Q012042	Tornillo exagonal M-6x15		12	12	12	12	12	12	12			
39	Q262040	Arandela muelle A-6		12	12	12	12	12	12	12			
40	Q232040	Arandela plana A-6		12	12	12	12	12	12	12			
41	R662614	Aislante base y techo 650x650x20		5	5	-	-	5	5	-			
41	R682623	Aislante base y techo 860x790x20		-	-	5	5	-	-	5			
42	R662613	Aislante lateral 650x530x20		3	-	-	-	3	-	-			
42	R672630	Aislante lateral 770x650x20		-	3	-	-	-	3	-			
42	R682623	Aislante lateral 860x790x20		-	-	3	3	-	-	3			
43	R662613	Aislante lateral 650x530x20		2	-	-	-	2	-	-			
43	R672630	Aislante lateral 770x650x20		-	2	-	-	-	2	-			
43	R682623	Aislante lateral 860x790x20		-	-	2	2	-	-	2			
44	R662681	Cuerpo interior horno		1	-	-	-	1	-	-			
44	R672673	Cuerpo interior horno		-	1	-	-	-	1	-			
44	R682674	Cuerpo interior horno		-	-	1	1	-	-	1			
	R662636	Refuerzo base de cuerpo interior		1	1	-	-	1	1	-			
	R682633	Refuerzo base de cuerpo interior		-	-	1	1	-	-	1			
	R682663	Refuerzo vertical de cuerpo interior		-	-	2	2	-	-	2			
	Q232040	Arandela plana A-6		8	8	21	21	8	8	21			Amarre refuerzos
	Q262040	Arandela muelle A-6		8	8	21	21	8	8	21			Amarre refuerzos
	Q162040	Tuerca exagonal M-6		8	8	21	21	8	8	21			Amarre refuerzos
45	Q222041	Remache exagonal M-4 inox.		24	28	28	28	24	28	28			

MOD.

HORNOS MIXTOS ELECTROMECHANICOS

ZONA

MUEBLE INTERIOR

PLANO

C-1445

ITEM	CODIGO	DENOMINACION	TEXTO	HMM-6/11	HMM-10/11	HMM-10/21	HMM-2-10/11	HMM-6/11 UL	HMM-10/11 UL	HMM-10/21 UL			NOTAS
46	R662800	Cubre cables		1	1	1	1	1	1	1			
47	Q232030	Arandela plana A-5		2	2	2	2	2	2	2			
48	Q012031	Tornillo exagonal M-5x10		2	2	2	2	2	2	2			

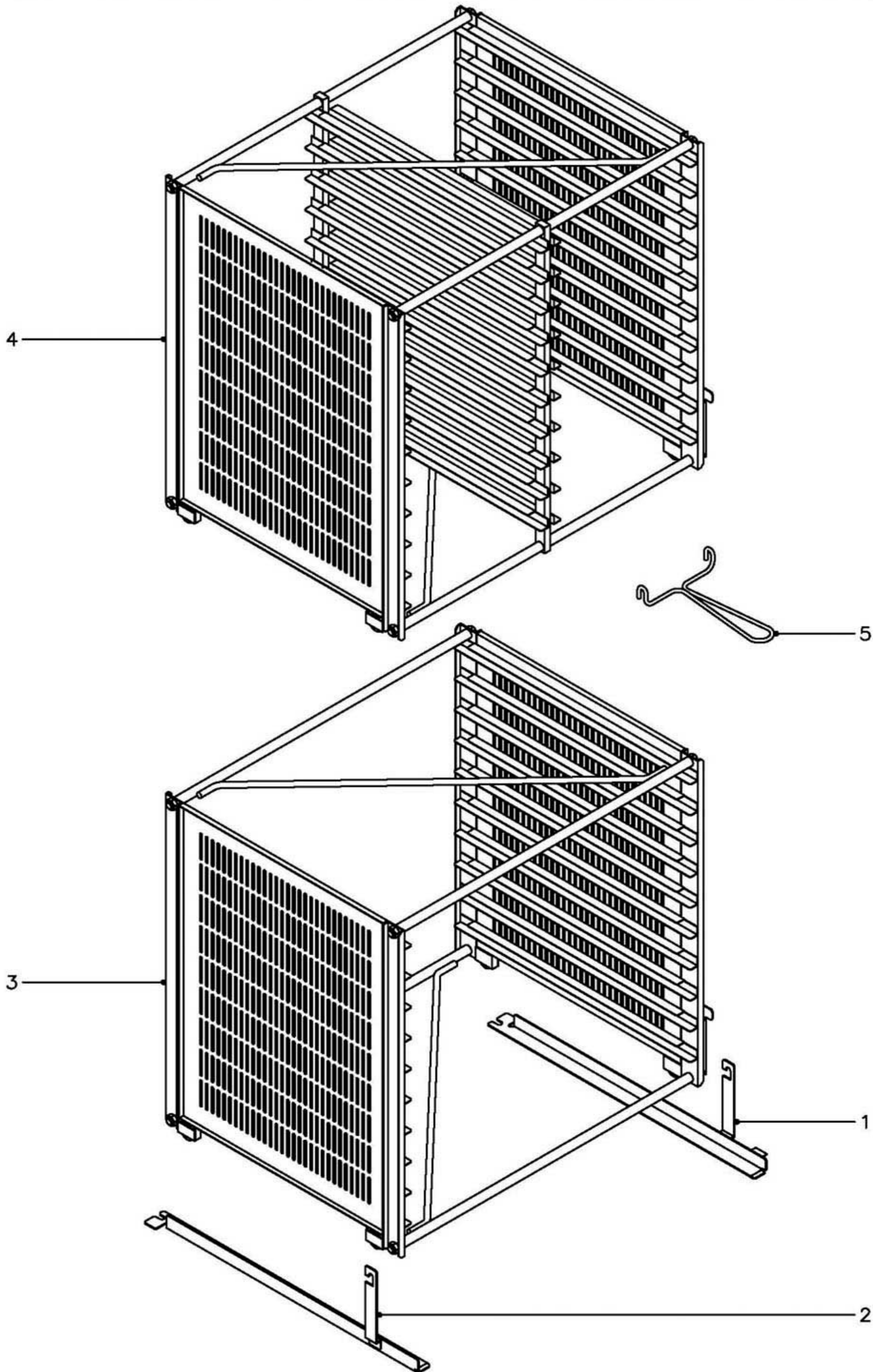

N plano
C-1446

Firma

Fecha
11-2003

Aparato
EXTRACTURAS PORTABANDEJAS
HORNOS MIX. ELECTROMECAVICOS

Lamina
4

Fagor Industrial S.Coop. **FAGOR** 
Oñate

ITEM	CODIGO	DENOMINACION	TEXTO	HMM-6/11	HMM-10/11	HMM-10/21	HMM-2-10/11	HMM-6/11 UL	HMM-10/11 UL	HMM-10/21 UL			NOTAS
1100002631 KIT EXSTRUCTURA PORTABANDE. 10/11				-	OP.	-	-	-	-	-			OP.= Opcional
1	R672623	Rail derecho		-	OP.	-	-	-	-	-			Optionnel
2	R672622	Rail izquierdo		-	OP.	-	-	-	-	-			In option
3	R672617	Exstructura portabandejas 10/11		-	OP.	-	-	-	-	-			
5	R672632	Tirador de exstructura		-	OP.	-	-	-	-	-			
1100002634 KIT EXSTRUCTURA PORTABANDE. 10/21				-	-	OP.	-	-	-	-			
1100002635 KIT EXSTRUCTURA PORTABANDE. 2-10/11				-	-	-	1	-	-	-			
1	R682659	Rail derecho		-	-	OP.	1	-	-	-			
2	R682658	Rail izquierdo		-	-	OP.	1	-	-	-			
3	R682617	Exstructura portabandejas 10/21		-	-	OP.	-	-	-	-			
4	R682618	Exstructura portabandejas 2-10/11		-	-	-	1	-	-	-			
5	R672632	Tirador de exstructura		-	-	OP.	1	-	-	-			

N plano
C-1447



Firma

Fecha

11-2003

Aparato

HORNOS MIX. ELECTROMECHANICOS

TURBINA

Laminas

5

Fagor Industrial S. Coop. Omatel

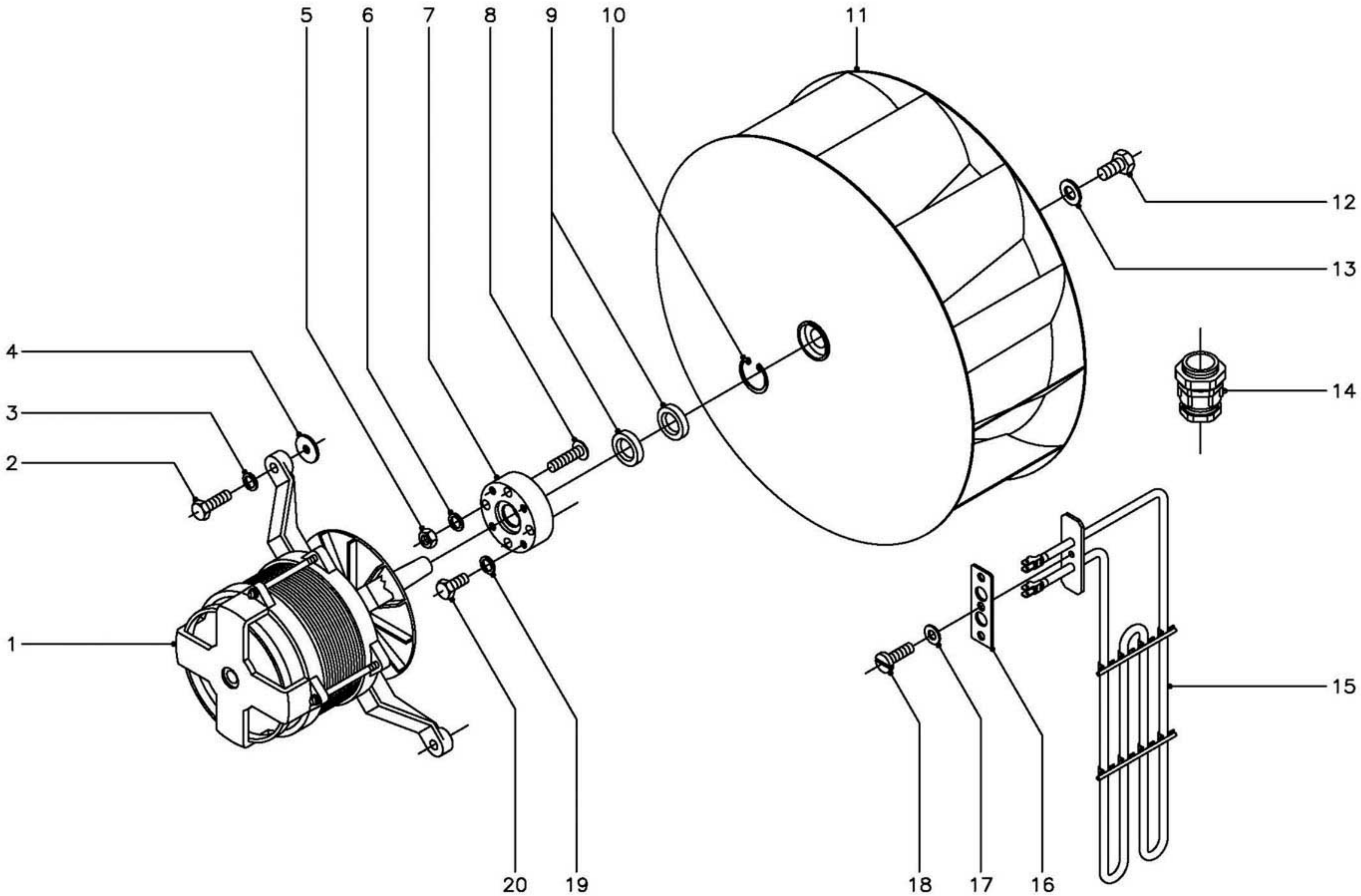

MOD.

HORNOS MIXTOS ELECTROMECHANICOS

ZONA

TURBINA

PLANO

C-1447

ITEM	CODIGO	DENOMINACION	TEXTO	HMM-6/11	HMM-10/11	HMM-10/21	HMM-2-10/11	HMM-6/11 UL	HMM-10/11 UL	HMM-10/21 UL			NOTAS
1	R253049	Conj. motor (230/400 V., 50/60 Hz.)		1	1	1	1	1	1	1			
2	Q012044	Tornillo exagonal M-6x25		4	4	4	4	4	4	4			
3	Q262040	Arandela muelle A-6		4	4	4	4	4	4	4			
4	Q301304	Arandela calzo Ø 23xØ 6,5x2		8	8	8	8	8	8	8			
5	Q162040	Tuerca exagonal M-6		4	4	4	4	4	4	4			
6	Q262040	Arandela muelle A-6		4	4	4	4	4	4	4			
7	R662623	Casquillo reten		1	1	1	1	1	1	1			
8	-	Perno M-6 (Caldeado a cuerpo)		4	4	4	4	4	4	4			
9	R662627	Reten Ø 28xØ 17x7		2	2	2	2	2	2	2			
10	Q302023	Anillo de seguridad Ø 28x1,2		1	1	1	1	1	1	1			
11	R253042	Turbina		1	1	1	1	1	1	1			
12	Q012063	Tornillo exagonal M-10x20		1	1	1	1	1	1	1			
13	R763010	Arandela seguridad Hanning		1	1	1	1	1	1	1			
14	R033002	Prensaestopas		1	1	1	1	1	1	1			
15	R663016	Resistencia 1500W., 230V.		6	-	-	-	6	-	-			
15	R673002	Resistencia 1500+1500W., 230V.		-	6	-	-	-	6	-			
15	R683000	Resistencia 2000+2000W., 230V.		-	-	6	6	-	-	6			
16	R693017	Junta resistencia 6/11		6	-	-	-	6	-	-			
16	R673063	Junta resistencia 10/11 y 10/21		-	6	6	6	-	6	6			
17	Q232030	Arandela plana A-5		6	18	18	18	6	18	18			
18	Q062031	Tornillo alomado M-5x10		6	18	18	18	6	18	18			
19	Q232030	Arandela muelle A-5		4	4	4	4	4	4	4			
20	Q012031	Tornillo exagonal M-5x10		4	4	4	4	4	4	4			

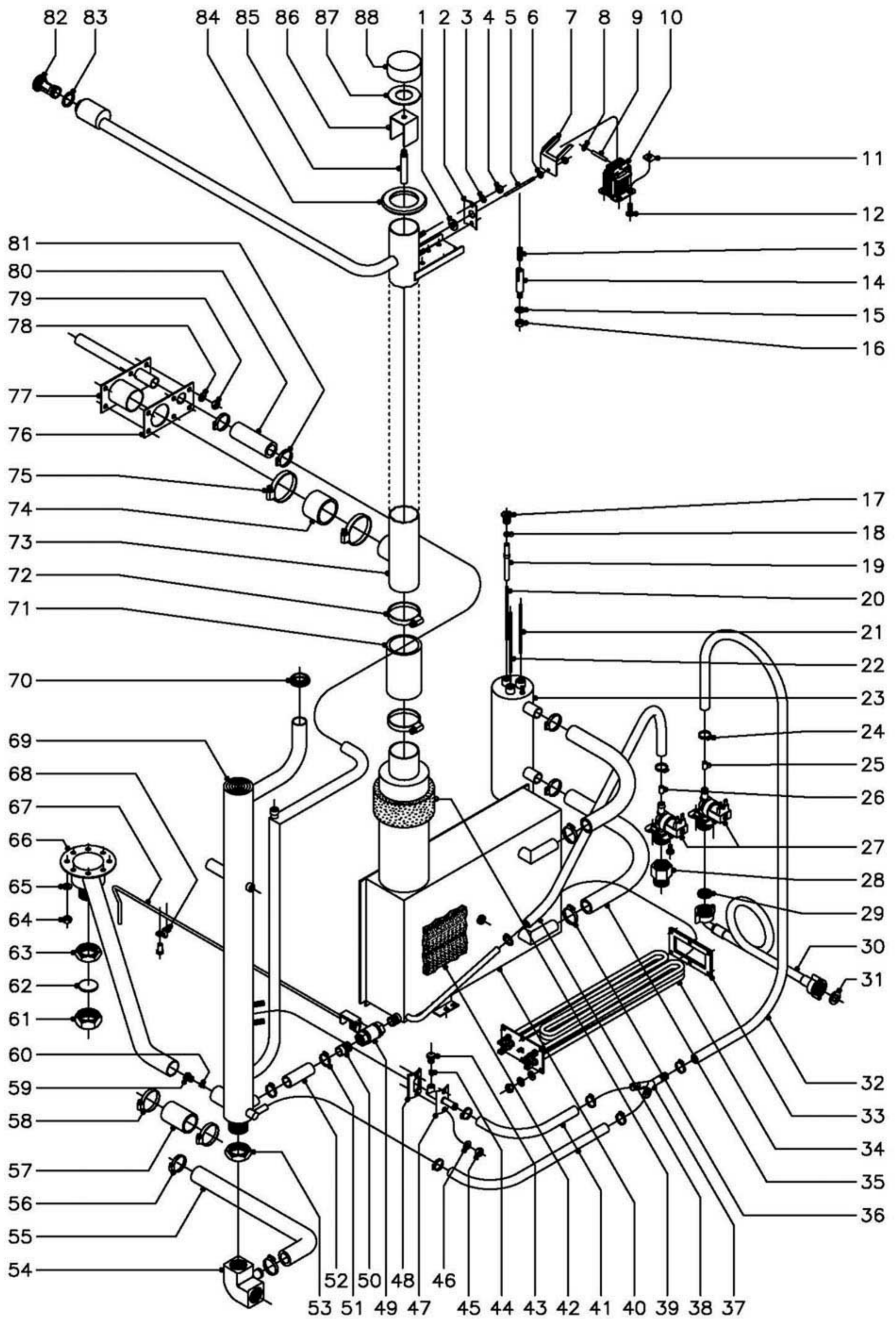

MOD.

HORNOS MIXTOS ELECTROMECHANICOS

ZONA

CIRCUITO DE AGUA

PLANO

C-1448

ITEM	CODIGO	DENOMINACION	TEXTO	HMM-6/11	HMM-10/11	HMM-10/21	HMM-2-10/11	HMM-6/11 UL	HMM-10/11 UL	HMM-10/21 UL			NOTAS
1	R675033	Junta palanca accionamiento		1	1	1	1	1	1	1			
2	T115105	Amarre junta a conduccion vahos		1	1	1	1	1	1	1			
3	Q242030	Arandela abanico A-5		2	2	2	2	2	2	2			
4	Q162030	Tuerca exagonal M-5		2	2	2	2	2	2	2			
5	R675014	Palanca accionamiento		1	1	1	1	1	1	1			
6	Q162020	Tuerca exagonal M-4		2	2	2	2	2	2	2			
7	R672640	Escuadra accionamiento		1	1	1	1	1	1	1			
8	Q301035	Sujecion rapida Ø4		2	2	2	2	2	2	2			
9	R675016	Pasador electroiman		1	1	1	1	1	1	1			
10	R663030	Electroiman		1	1	1	1	1	1	1			
11	Q221012	Tuerca rapida M-5		2	2	2	2	2	2	2			
12	Q152004	Tornillo aplastado M-5x13		2	2	2	2	2	2	2			
13	Z883001	Resorte		1	1	1	1	1	1	1			
14	R665027	Guia resorte		1	1	1	1	1	1	1			
15	Q242040	Arandela abanico A-6		1	1	1	1	1	1	1			
16	Q162040	Tuerca exagonal M-6		1	1	1	1	1	1	1			
17	R345058	Racord amarre electrodos		3	3	3	3	3	3	3			
18	Q163020	Tuerca exagonal M-4		6	6	6	6	6	6	6			
19	R345059	Guia aislante de electrodos		3	3	3	3	3	3	3			
20	R345063	Electrodo nivel bajo L=116		1	1	1	1	1	1	1			
21	R345060	Electrodo nivel alto L=106		1	1	1	1	1	1	1			
22	R345064	Electrodo de masa L=131		1	1	1	1	1	1	1			
23	R665046	Cuerpo de niveles		1	-	-	-	1	-	-			
23	R025011	Cuerpo de niveles		-	1	1	1	-	1	1			
24	Q881302	Abrazadera 12 - 20		4	4	4	4	4	4	4			
25	P443042	Regulador caudal (3 l./m.) negro		1	1	1	1	1	1	1			
26	Z601156	Regulador caudal (8 l./m.) rojo		1	1	1	1	1	1	1			
27	Z701135	Electrovalvula entrada agua		2	2	2	2	2	2	2			
	Q032021	Tornillo alomado M-4x10		4	4	4	4	4	4	4			

ITEM	CODIGO	DENOMINACION	TEXTO	HMM-6/11	HMM-10/11	HMM-10/21	HMM-2-10/11	HMM-6/11 UL	HMM-10/11 UL	HMM-10/21 UL			NOTAS
28	T125033	Adaptador a rosca UL		-	-	-	-	1	1	1			
29	Z701132	Filtro-junta entrada de agua		1	1	1	1	1	1	1			
30	Z601114	Manguera entrada de agua		2	2	2	2	-	-	-			
31	Q307031	Arandela junta Ø24xØ14x3		2	2	2	2	2	2	2			
32	3676900	Tubo de goma Ø17xØ10x900		1	1	1	1	1	1	1			
33	R145012	Junta cierre resistencias		1	2	2	2	1	2	2			
34	R143000	Resistencia (3000W.x3, 230 V.)		1	2	2	2	1	2	2			
	Q232030	Arandela plana A-5		6	12	12	12	6	12	12			
	Q242030	Arandela abanico A-5		6	12	12	12	6	12	12			
	Q162030	Tuerca exagonal M-5		6	12	12	12	6	12	12			
35	3715600	Tubo silicona forra. Ø26xØ18x400		2	2	2	2	2	2	2			
36	Q881305	Abrazadera 25 - 40		4	4	4	4	4	4	4			
37	Z201106	Racord en " Y "		1	1	1	1	1	1	1			
38	3676900	Tubo de goma Ø17xØ10x500		1	1	1	1	1	1	1			
39	R665052	Aislante salida generador		1	-	-	-	-	-	-			
39	R345013	Aislante salida generador		-	1	1	1	-	-	-			
39	R672630	Aislante salida generador		-	-	-	-	1/2.	1/2.	1/2.			
40	R665042	Generador de vapor		1	-	-	-	1	-	-			
40	R675024	Generador de vapor		-	1	1	1	-	1	1			
41	3676900	Tubo de goma Ø17xØ10x400		2	2	2	2	2	2	2			
42	R665051	Aislante cuerpo generador		1	-	-	-	-	-	-			
42	R345011	Aislante cuerpo generador		-	1	1	1	-	-	-			
42	R672630	Aislante cuerpo generador		-	-	-	-	1/2.	1/2.	1/2.			
43	Z651931	Tobera		1	1	1	1	1	1	1			
44	Z651932	Rodete		1	1	1	1	1	1	1			
45	Q162030	Tuerca exagonal M-5		2	2	2	2	2	2	2			
46	Q232030	Arandela plana A-5		2	2	2	2	2	2	2			
47	R015007	Conduccion vahos		1	1	1	1	1	1	1			

MOD.

HORNOS MIXTOS ELECTROMECAVICOS

ZONA

CIRCUITO DE AGUA

PLANO

C-1448

ITEM	CODIGO	DENOMINACION	TEXTO	HMM-6/11	HMM-10/11	HMM-10/21	HMM-2-10/11	HMM-6/11 UL	HMM-10/11 UL	HMM-10/21 UL			NOTAS
48	R345108	Junta conduccion vahos		1	1	1	1	1	1	1			
49	R015034	Cuerpo grifo vaciado		1	1	1	1	1	1	1			
50	R345014	Manguito grifo vaciado		1	1	1	1	1	1	1			
51	Q881304	Abrazadera 20 - 32		2	2	2	2	2	2	2			
52	3715600	Tubo silicona Ø26xØ18x120		1	1	1	1	1	1	1			
53	Q223014	Contratuerca 1"		1	1	1	1	1	1	1			
54	R665067	Codo desague		1	1	1	1	1	1	1			
55	3715600	Tubo silicona Ø26xØ18x1000		1	1	1	1	1	1	1			
56	Q881304	Abrazadera 20 - 32		2	2	2	2	2	2	2			
57	3714100	Tubo silicona Ø38xØ31x100		1	1	1	1	1	1	1			
58	Q881305	Abrazadera 25 - 40		2	2	2	2	2	2	2			
59	Z651931	Tobera		1	1	1	1	1	1	1			
60	Z651932	Rodete		1	1	1	1	1	1	1			
61	R665053	Tuerca tapon 1"		1	1	1	1	1	1	1			
62	R015011	Arandela junta tapon Ø34x3		1	1	1	1	1	1	1			
63	Q223014	Contratuerca 1"		1	1	1	1	1	1	1			
64	Q162040	Tuerca exagonal M-6		8	8	8	8	8	8	8			
65	Q232040	Arandela plana A-6		8	8	8	8	8	8	8			
66	R675022	Tubo de desague		1	1	-	-	1	1	-			
66	R685006	Tubo de desague		-	-	1	1	-	-	1			
67	R342803	Palanca de grifo de vaciado		1	1	-	-	1	1	-			
67	R032804	Palanca de grifo de vaciado		-	-	1	1	-	-	1			
68	Q901306	Grapa amarre palanca grifo		1	1	1	1	1	1	1			
	Q412002	Remache tubular Ø 4x7,5		2	2	2	2	2	2	2			
69	R665048	Tubo retorno y chimenea		1	-	-	-	1	-	-			
69	R675030	Tubo retorno y chimenea		-	1	-	-	-	1	-			
69	R685010	Tubo retorno y chimenea		-	-	1	1	-	-	1			
70	N503017	Soporte termostato		1	1	1	1	1	1	1			Pasamuros chimenea
71	R345020	Tubo empalme generador		1	1	1	1	1	1	1			

MOD.

HORNOS MIXTOS ELECTROMECHANICOS

ZONA

CIRCUITO DE AGUA

PLANO

C-1448

ITEM	CODIGO	DENOMINACION	TEXTO	HMM-6/11	HMM-10/11	HMM-10/21	HMM-2-10/11	HMM-6/11 UL	HMM-10/11 UL	HMM-10/21 UL			NOTAS
72	Q881307	Abrazadera 40 - 60		2	2	2	2	2	2	2			
73	R675019	Conjunto chimenea		1	1	1	1	-	-	-			
73	R670317	Entrada desincrustante y chimenea		-	-	-	-	1	1	-			
73	R680306	Entrada desincrustante y chimenea		-	-	-	-	-	-	1			
74	3710900	Tubo silicona Ø51xØ43x40		1	1	1	1	1	1	1			
75	Q881307	Abrazadera 40 - 60		2	2	2	2	2	2	2			
76	R675038	Junta entrada y retorno		1	1	1	1	1	1	1			
77	R662658	Tubo entrada y retorno vapor		1	-	-	-	1	-	-			
77	R022613	Tubo entrada y retorno vapor		-	1	1	1	-	1	1			
78	Q232040	Arandela plana A-6		6	6	6	6	6	6	6			
79	Q162040	Tuerca exagonal M-6		6	6	6	6	6	6	6			
80	3715600	Tubo silicona forra. Ø26xØ18x100		1	1	1	1	1	1	1			
81	Q881304	Abrazadera 20 - 32		2	2	2	2	2	2	2			
82	R670324	Tapon desincrustante		-	-	-	-	1	1	1			
83	R670325	Junta desincrustante		-	-	-	-	1	1	1			
84	R662813	Pasamuros chimenea		1	1	1	1	1	1	1			
85	R675008	Union retencion de vapores		1	1	1	1	1	1	1			
86	R675005	Guia retencion de vapores		1	1	1	1	1	1	1			
87	R675007	Junta retencion de vapores		1	1	1	1	1	1	1			
88	R675006	Retencion de vapores		1	1	1	1	1	1	1			

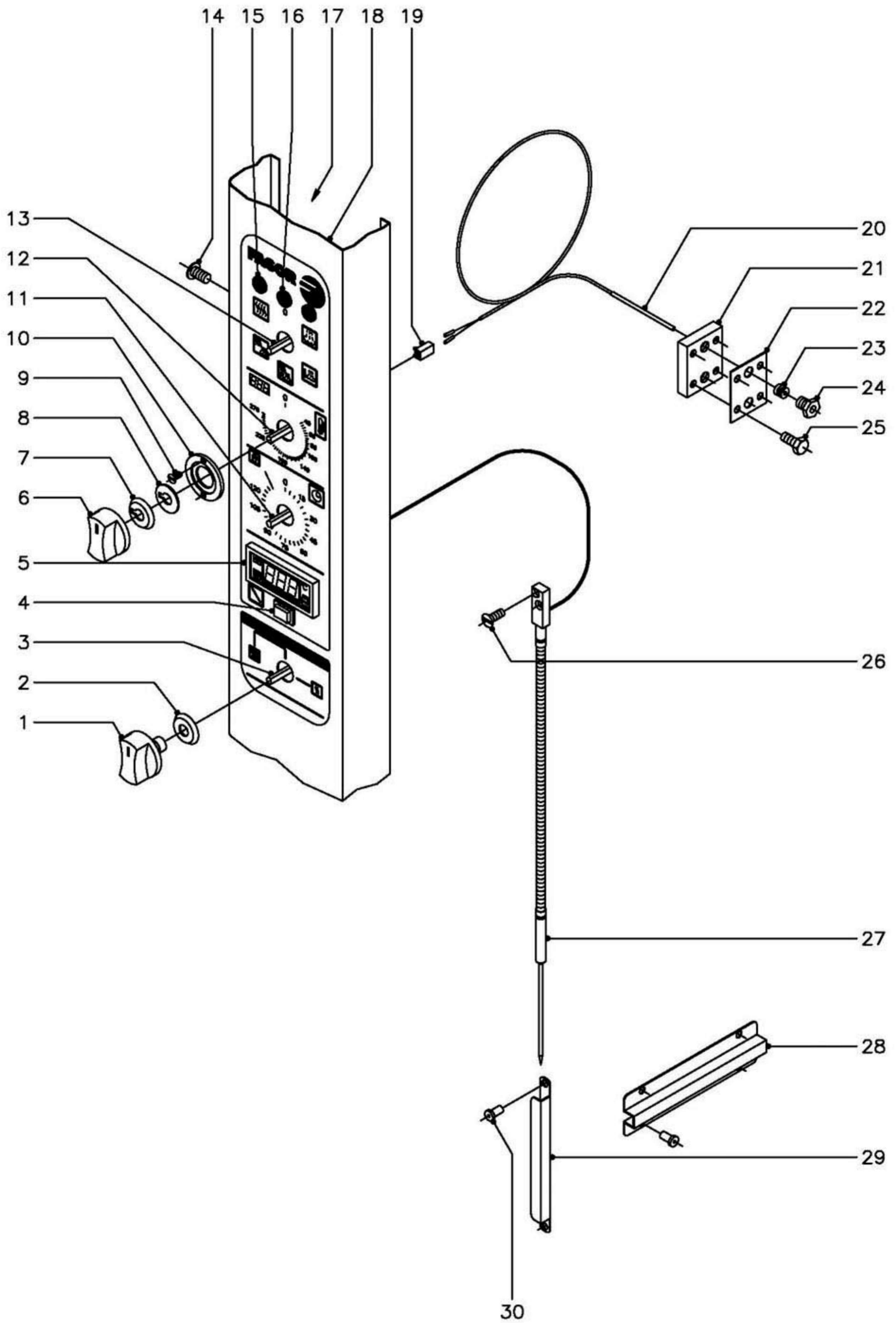

MOD.

HORNOS MIXTOS ELECTROMECAVICOS

ZONA

SISTEMA ELECTRICO PORTAMANDOS

PLANO

C-1449

ITEM	CODIGO	DENOMINACION	TEXTO	HMM-6/11	HMM-10/11	HMM-10/21	HMM-2-10/11	HMM-6/11 UL	HMM-10/11 UL	HMM-10/21 UL			NOTAS
1	R663062	Boton de mando (conmutadores)		2	3	3	3	2	3	3			FAGOR
1	R663070	Boton de mando (conmutadores)		-	-	-	-	2	3	3			MARKET-FORGE
2	R663046	Junta (conmutadores)		2	3	3	3	2	3	3			
3	R753000	Conmutador de potencia		-	1	1	1	-	1	1			
4	R743008	Interruptor regulacion sonda		1	1	1	1	1	1	1			
5	R743091	Termostato digital ° C.		1	1	1	1	-	-	-			
5	R743035	Termostato digital ° F.		-	-	-	-	1	1	1			
6	R663063	Boton de mando (circuito impreso)		1	1	1	1	1	1	1			FAGOR
6	R663071	Boton de mando (circuito impreso)		-	-	-	-	1	1	1			MARKET-FORGE
7	R663045	Junta (circuito impreso)		1	1	1	1	1	1	1			
8	R662810	Arandela guia		1	1	1	1	1	1	1			
9	Q151346	Tornillo avellanado M-3x5		2	2	2	2	2	2	2			
10	R662809	Guia boton de mando		1	1	1	1	1	1	1			
11	R723000	Temporizador manual		1	1	1	1	1	1	1			
12	R743013	Termostato electronico 270°C.		1	1	1	1	-	-	-			
12	R693058	Termostato electronico 500°F.		-	-	-	-	1	1	1			
13	R743002	Conmutador de funciones		1	1	1	1	1	1	1			
14	Q152004	Tornillo aplastado M-5x13		3	3	3	3	3	3	3			
15	R693056	Piloto ambar		2	2	2	2	2	2	2			
16	R693055	Piloto verde		1	1	1	1	1	1	1			
17	R742803	Soporte componentes		1	1	1	1	1	1	1			
18	R742807	Panel portamandos 6/11		1	-	-	-	1	-	-			
18	R752805	Panel portamandos 10/11 y 10/21		-	1	1	1	-	1	1			
19	R663092	Conector 2 vias		1	1	1	1	1	1	1			
20	R663090	Conjunto termopar L=1500		1	1	1	1	1	1	1			
21	R662659	Pasamuros doble para sonda		1	1	1	1	1	1	1			
22	R692811	Junta pasamuros doble		1	1	1	1	1	1	1			
23	R662652	Bicono cierre sonda		1	1	1	1	1	1	1			
24	R662629	Racord cierre sonda		1	1	1	1	1	1	1			

MOD.

HORNOS MIXTOS ELECTROMECA NIOS

ZONA

SISTEMA ELECTRICO PORTAMANDOS

PLANO

C-1449

ITEM	CODIGO	DENOMINACION	TEXTO	HMM-6/11	HMM-10/11	HMM-10/21	HMM-2-10/11	HMM-6/11 UL	HMM-10/11 UL	HMM-10/21 UL			NOTAS
25	Q012021	Tornillo exagonal M-4x10		4	4	4	4	4	4	4			
26	Q042022	Tornillo avellanado M-4x15		2	2	2	2	2	2	2			
27	R663091	Conjunto sonda nucleo		1	-	-	-	1	-	-			
27	R673059	Conjunto sonda nucleo		-	1	1	1	-	1	1			
28	R662625	Soporte de sonda		1	-	-	-	1	-	-			
29	R672643	Soporte de sonda		-	1	1	1	-	1	1			
30	Q412002	Remache tubular Ø 4x7,5		4	2	2	2	4	2	2			

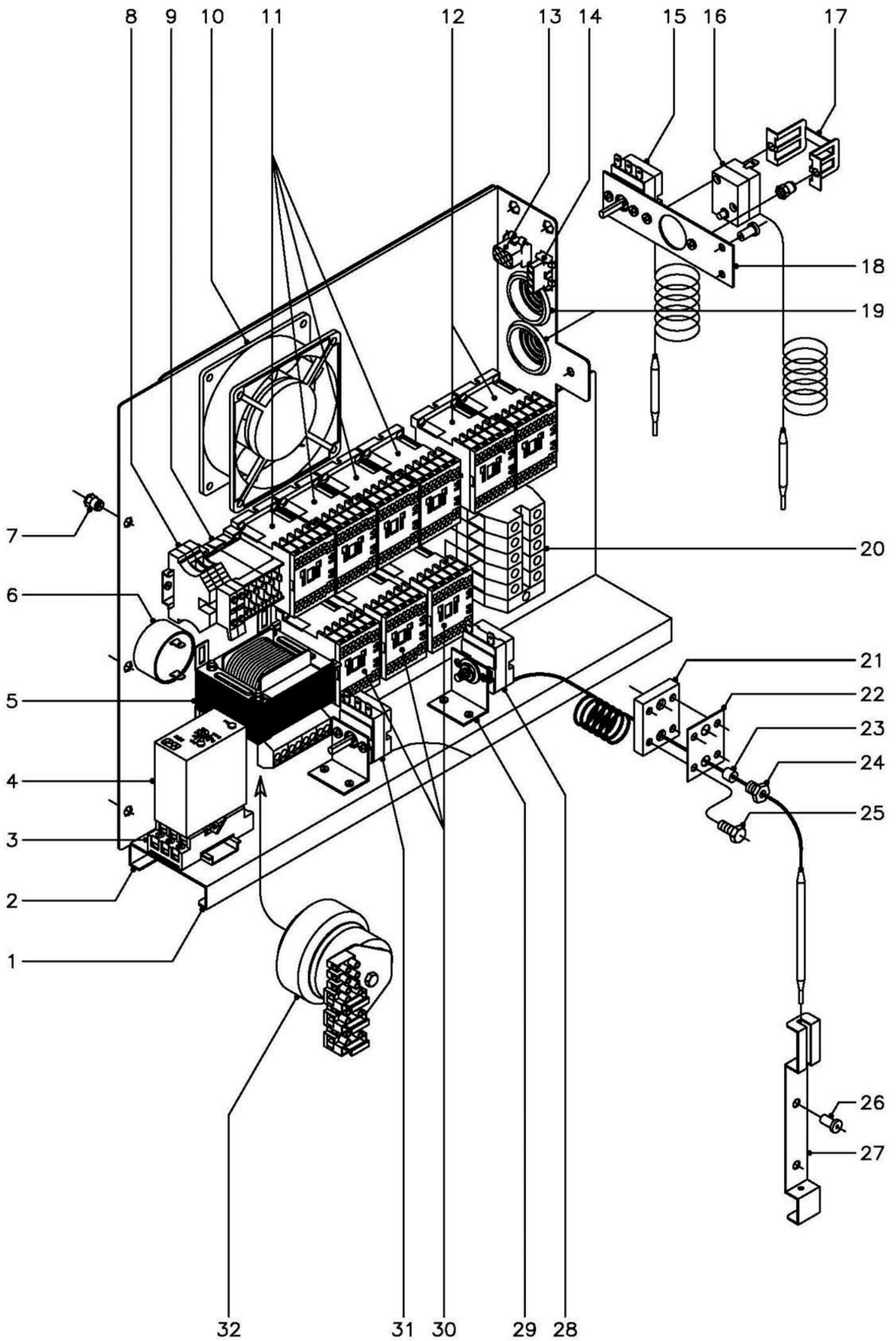

N plano
C-1450

Firma

Fecha
11-2003

Aparato
CUADRO ELECTRICO
HORNOS MIX. ELECTROMECHANICOS

Lamina
8

Fagor Industrial S.Coop. **FAGOR**
Oferta

MOD.

HORNOS MIXTOS ELECTROMECAVICOS

ZONA

CUADRO ELECTRICO

PLANO

C-1450

ITEM	CODIGO	DENOMINACION	TEXTO	HMM-6/11	HMM-10/11	HMM-10/21	HMM-2-10/11	HMM-6/11 UL	HMM-10/11 UL	HMM-10/21 UL			NOTAS
1	R663081	Panel cuadro electrico		1	1	1	1	1	1	1			
2	R663018	Contra guia panel cuadro		1	1	1	1	1	1	1			
	Q412002	Remache tubular Ø4x7,5		7	7	7	7	7	7	7			
3	R743009	Base enchufable		1	1	1	1	1	1	1			
	Z123018	Guia contactor L=55		1	1	1	1	1	1	1			
4	R343072	Detector de niveles		1	1	1	1	-	-	-			
4	R743031	Detector de niveles		-	-	-	-	1	1	1			
5	R503005	Transformador		1	1	1	1	-	-	-			
6	R693067	Zumbador		1	1	1	1	1	1	1			
7	Q221342	Remache exagonal M-5		3	3	3	3	3	3	3			
8	R073005	Bornas portafusibles		2	2	2	2	2	2	2			
	P184011	Cartucho fusible 4 A.		2	2	2	2	2	2	2			
	Z263303	Tope final		1	1	1	1	1	1	1			
9	Z683087	Contacto 3TF20 01 - 3AL2 (230 V.)		1	1	1	1	1	1	1			
	Z263303	Tope final		1	1	1	1	1	1	1			
10	Z103066	Ventilador		1	1	1	1	1	1	1			
11	Z203050	Contacto sirius 3RT-1016-2AP01		2	4	4	4	2	4	4			
	R693009	Guia contactor L=250		1	1	1	1	1	1	1			
12	Z203050	Contacto sirius 3RT-1016-2AP01		2	2	2	2	2	2	2			
	Z403016	Guia contactor L=100		1	1	1	1	1	1	1			
13	-	Conector hembra 6 vias		1	1	1	1	1	1	1			
14	-	Conector hembra 4 vias		1	1	1	1	1	1	1			
15	R343100	Termostato de condensacion		1	1	1	1	1	1	1			
	Q153111	Tornillo alomado M-4x8		2	2	2	2	2	2	2			
16	Z213014	Termostato Tecasa de seguridad		1	1	1	1	1	1	1			
17	Z203060	Amarre limitador Tecasa		1	1	1	1	1	1	1			
	Q221341	Remache exagonal M-4		2	2	2	2	2	2	2			
	Q153111	Tornillo alomado M-4x8		2	2	2	2	2	2	2			
18	R673061	Soporte amarre termostatos		1	1	1	1	1	1	1			

MOD.

HORNOS MIXTOS ELECTROMECHANICOS

ZONA

CUADRO ELECTRICO

PLANO

C-1450

ITEM	CODIGO	DENOMINACION	TEXTO	HMM-6/11	HMM-10/11	HMM-10/21	HMM-2-10/11	HMM-6/11 UL	HMM-10/11 UL	HMM-10/21 UL			NOTAS
	Q412002	Remache tubular Ø4x7,5		2	2	2	2	2	2	2			
19	N103013	Pasacables		2	2	2	2	2	2	2			
20	P453025	Borne gris fases 10		3	-	-	-	3	-	-			
	R263003	Borne gris fases 35		-	3	3	3	-	3	3			
	Z263302	Borne azul neutro 10		1	-	-	-	1	-	-			
	R673010	Borne azul neutro 35		-	1	1	1	-	1	1			
	P453026	Borne verde-amarillo tierra 10		1	-	-	-	1	-	-			
	Z103035	Borne verde-amarillo tierra 35		-	1	1	1	-	1	1			
	Z263303	Tope final		1	-	-	-	1	-	-			
	Z683096	Tope final 35		-	1	1	1	-	1	1			
	Z683068	Señalización bornes		1	1	1	1	1	1	1			
	R663055	Guía contactor 120		1	1	1	1	1	1	1			
21	R662659	Pasamuros doble para sonda		1	1	1	1	1	1	1			
22	R692811	Junta pasamuros doble		1	1	1	1	1	1	1			
23	R662662	Junta cierre bulbo limitador		1	1	1	1	1	1	1			
24	R662629	Racord cierre sonda		1	1	1	1	1	1	1			
25	Q012021	Tornillo exagonal M-4x10		4	4	4	4	4	4	4			
26	Q412002	Remache tubular Ø4x7,5		2	2	2	2	2	2	2			
27	R662630	Soporte de bulbo		1	1	1	1	1	1	1			
28	R243016	Termostato limitador temperatura		1	1	1	1	1	1	1			
29	R343039	Soporte de termostatos		2	2	2	2	2	2	2			
30	Z203050	Contacto sirius 3RT-1016-2AP01		1	3	3	3	1	3	3			
	Z103084	Guía contactor 138		1	1	1	1	1	1	1			
31	R343018	Termostato a tubo retorno vapor		1	1	1	1	1	1	1			
32	R723063	Transformador UL		-	-	-	-	1	1	1			

ITEM	CODIGO	DENOMINACION	TEXTO	HMM-6/11	HMM-10/11	HMM-10/21	HMM-2-10/11	HMM-6/11 UL	HMM-10/11 UL	HMM-10/21 UL			NOTAS
	R746501	Folleto de instrucciones (FAGOR)		1	1	1	1	-	-	-			
	R696516	Folleto de instruccio. (FAGOR UL)		-	-	-	-	1	1	1			
	R746503	Folleto de instrucciones (M F)		-	-	-	-	1	1	1			
	R743039	Esquema electrico adhesivo		1	-	-	-	-	-	-			Plano HC-73218
	R743040	Esquema electrico adhesivo (MF)		-	-	-	-	1	-	-			Plano HC-74738
	R743041	Esquema electrico adhesivo (UL)		-	-	-	-	1	-	-			Plano HC-74748
	R753013	Esquema electrico adhesivo		-	1	1	1	-	-	-			Plano HC-73219
	R753022	Esquema electrico adhesivo (MF)		-	-	-	-	-	1	1			Plano HC-74739
	R753024	Esquema electrico adhesivo (UL)		-	-	-	-	-	1	1			Plano HC-74749
	R703040	Esquema electrico de montaje		1	-	-	-	1	-	-			Plano HD-12585
	R503004	Esquema electrico de montaje		-	1	1	1	-	1	1			Plano HD-12493
	R503009	Instalacion electrica HMM		1	1	1	1	-	-	-			
	R503008	Instalacion electrica HMM (UL)		-	-	-	-	1	1	1			
	R693066	Cableado fuerza conveccion		1	-	-	-	-	-	-			
	R743062	Cableado fuerza conveccion (UL)		-	-	-	-	1	-	-			
	R143005	Cableado fuerza conveccion		-	1	1	1	-	-	-			
	R143015	Cableado fuerza conveccion (UL)		-	-	-	-	-	1	1			
	R663074	Instalacion fuerza cuadro electrico		1	-	-	-	-	-	-			
	R743060	Instalacion fuerza cuadro elec. (UL)		-	-	-	-	1	-	-			
	R673013	Instalacion fuerza cuadro electrico		-	1	1	1	-	-	-			
	R753020	Instalacion fuerza cuadro elec. (UL)		-	-	-	-	-	1	1			
	R663095	Cableado luz interior		1	1	1	1	1	1	1			
	R663094	Cableado luz puerta		1	1	1	1	-	-	-			
	R693053	Cableado luz puerta (UL)		-	-	-	-	1	1	1			
	3713900	Funda roja-negra Ø6,4x500		1	1	1	1	1	1	1			En cableado puerta
	R663075	Cableado fuerza vapor		1	-	-	-	-	-	-			

ITEM	CODIGO	DENOMINACION	TEXTO	HMM-6/11	HMM-10/11	HMM-10/21	HMM-2-10/11	HMM-6/11 UL	HMM-10/11 UL	HMM-10/21 UL			NOTAS
	R743063	Cableado fuerza vapor		-	-	-	-	1	-	-			
	R143004	Cableado fuerza vapor		-	1	1	1	-	-	-			
	R143014	Cableado fuerza vapor		-	-	-	-	-	1	1			
	R143009	Instalacion doble potencia		-	1	1	1	-	-	-			
	R143016	Instalacion doble potencia (UL)		-	-	-	-	-	1	1			
	R693068	Indicador cambio de tension		1	-	-	-	-	-	-			
	R703014	Indicador cambio de tension		-	1	1	1	-	-	-			
	R693008	Indicador cambio de tension (UL)		-	-	-	-	1	1	1			
	R696504	Etiqueta de sanidad		-	-	-	-	1	1	1			
	R696506	Etiqueta puerta caliente		-	-	-	-	1	1	1			
	R696507	Etiqueta de precaucion		-	-	-	-	2	2	2			
	R696508	Etiqueta de fusibles		-	-	-	-	1	1	1			
	R696512	Etiqueta de conexión		-	-	-	-	1	1	1			
	R746502	Etiqueta descalcificacion		-	-	-	-	1	1	1			
	Z400515	Bisagra (Amarre a pared)		-	-	-	-	1	1	1			
	R696511	Etiqueta embalaje Market-Forge		-	-	-	-	4	4	4			

ITEM	CODIGO	DENOMINACION	TEXTO	MFHMM-10-21													NOTAS
		PIEZAS A ELIMINAR															
15	R683000	Resistencia (2000+2000W., 230 V.)		6													Plano C-1447
34	R143000	Resistencia (3000W.x3, 230 V.)		2													Plano C-1448
		PIEZAS A INTRODUCIR															
15	R763000	Resistencia (2000+2000W., 278 V.)		6													Plano C-1447
34	R763001	Resistencia (3000W.x3, 278 V.)		2													Plano C-1448
S/N	R763002	Transformador cuadro de mandos		1													
S/N	R763003	Cableado transformador		1													
S/N	R763004	Soporte transformador		1													
S/N	R763005	Esquema electrico adhesivo		1													Plano HC-74954

MOD.

HORNOS MIXTOS ELECTROMECHANICOS

ZONA

PIEZAS A INTRODUCIR PARA LA VERSION (220/240 V. 1N)

PLANO

ITEM

CODIGO

DENOMINACION

TEXTO

HMM-6/11

HMM-10/11

NOTAS

R663048

Condensador para motor de turbina

1

1

R013019

Cableado para condensador

1

1

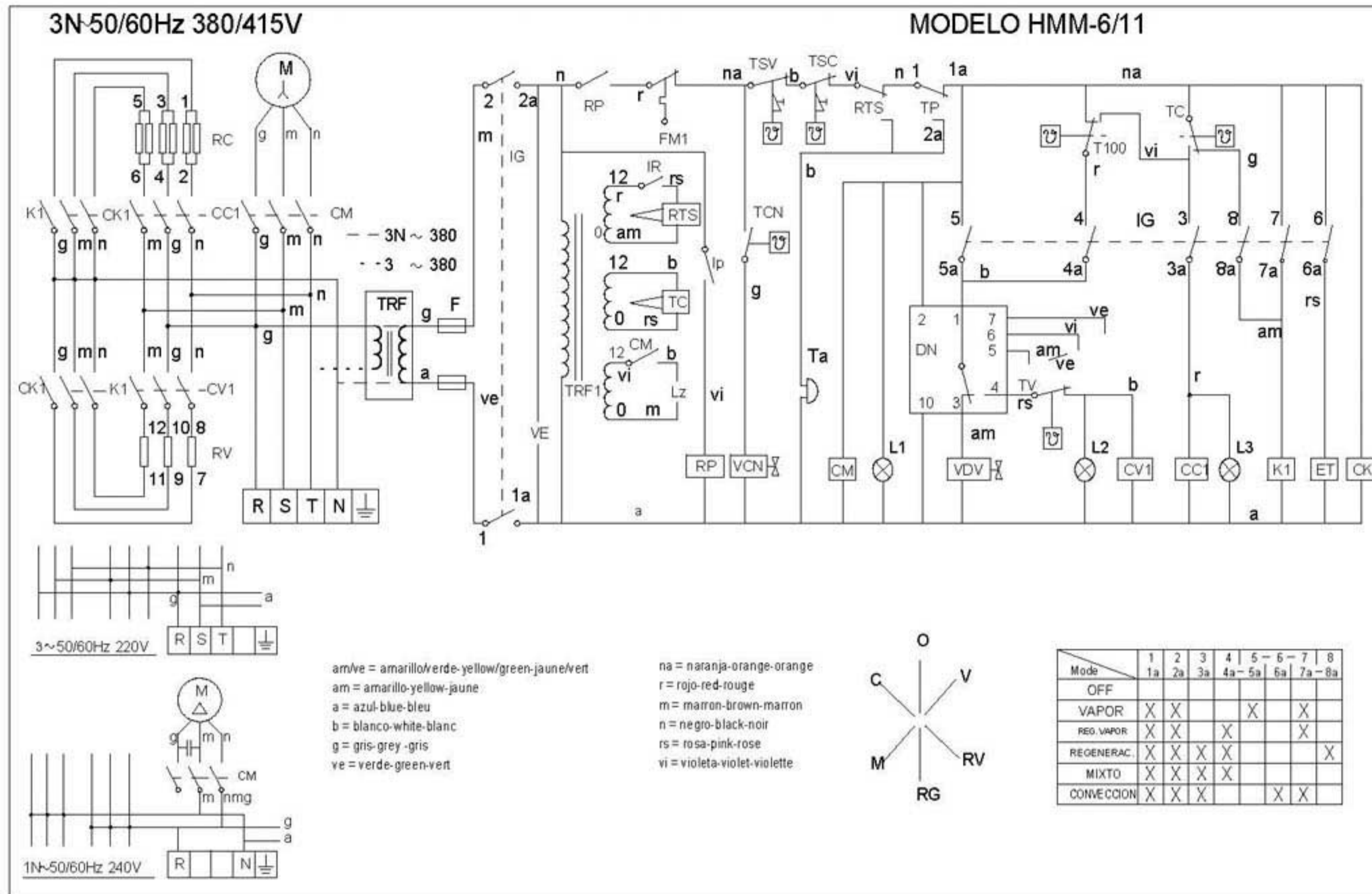

R-743039 HC-73218

- IP = Interruptor puerta
- IG = Interruptor general
- F = Fusible
- CM = Contactor motor
- VDV = Electroválvula calderin
- DN = Detector de nivel
- FM1 = Térmico motor
- Tsv = Termostato seguridad vapor
- Tsc = Termostato seguridad cámara
- Lz = Luz interior
- IR = Selector regulador sonda nucleo
- RTS = Regulador temperatura sonda nucleo
- RV = Resistencias vapor
- VE = Ventilador cuadro eléctrico
- Ta = Timbre avisador
- Tp = Temporizador
- Rp: Relé puerta
- ET = Electroimán de apertura de tiro
- Ic = Selector de potencia
- VCN = Electroválvula de condensación de vapor
- TC = Termostato cámara
- T100 = Termostato fijo 100°C
- TV = Termostato vapor
- M1 = Motor
- CC1 CC2 = Contactor resistencia cámara
- CV1 CV2 = Contactor resistencia vapor
- CK1, Ck2, K1, K2 = Relé resistencias
- TCN = Termostato de condensacion de vapor
- RC = Resistencias cámara
- TRF = Transformador
- L1 = Lámpara de funcionamiento
- L2 = Lámpara de calentamiento vapor
- L3 = Lámpara de calentamiento cámara

		3~50/60Hz 220V			
		3N~50/60Hz 380/415V		R-743039	
Nº	Pieza	Cant.	Material	Nº Clasificación	Acabado
Nº	Modificación	Propuesta de		Fecha	Tolerancias generales
1	Introducir RP	Maillo		25/2/2002	<5± 5-25± 25-50±
		Firma		Fecha	
Dibujado		Irabxe		13/11/98	
Proyectado		FAGOR			
Comprobado		Fagor Industrial, Koop Elk, Mugatua			
Escala		HORNO MIXTO HMM			
Plano hau ez da etxe erabil ez bermeza gure baimentz gabe					Mecanizado superficial
					Plano numero
					HC-73218 -1
					Sustituye al N°
					Sustituido por

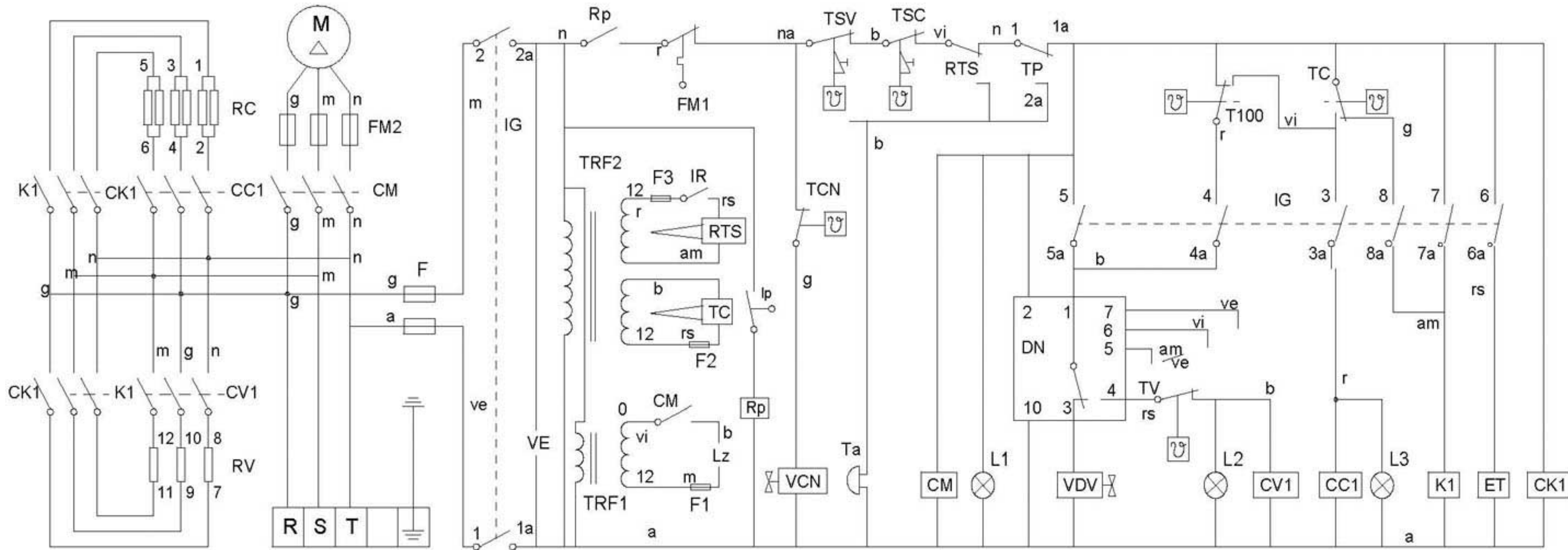

- FM2 = Motor fuse
- IP = Door's switch
- IG = General switch
- F = Fuse
- CM = Motor's relay
- VDV = Steamer's solenoid
- DN = Water level control
- FM1 = Motor's thermal protection
- TSV = Steamer's security thermostat
- TSC = Convection's security thermostat
- LZ = Indoor light
- IR = Probe selector
- RTS = Probe controller
- RV = Steamer elements

- ET = Chimney solenoid
- VCN = Steamer condenser solenoid
- TC = Convection thermostat
- T100 = 100 °C thermostat
- TV = Steamer's thermostat
- M = Motor
- CC1 = Heating air relays
- CV1 = Heating water relays
- CK1, K1 = Elements relays
- TCN = Steam condenser thermostat
- RC = Heating element
- TRF2= Transformer (Electronic thermostat)

- VE = Control panel's fan
- Ta = Alarm
- Tp = Manual Timer
- F1, F2, F3 = Transformer fuse
- TRF1 = Transformer (Indoor light)
- L1 = Pilot lamp (on/off)
- L2 = Pilot lamp (Heating water)
- L3 = Pilot lamp (Heating air)
- Rp = Door's Relay

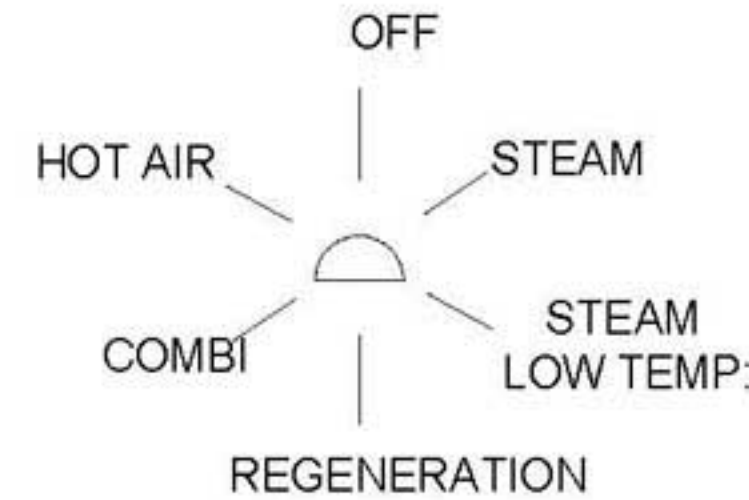

- am/ve = amarillo/verde-yellow/green-jaune/vert
- am = amarillo-yellow-jaune
- a = azul-blue-bleu
- b = blanco-white-blanc
- g = gris-grey -gris
- ve = verde-green-vert

Mode	1 1a	2 2a	3 3a	4 4a	5 5a	6 6a	7 7a	8 8a
OFF								
STEAM	X	X			X		X	
STEAM LOW TEMP	X	X		X			X	
REGENERATION	X	X	X	X				X
COMBI	X	X	X	X				
HOT AIR	X	X	X			X	X	

- na = naranja-orange-orange
- r = rojo-red-rouge
- m = marron-brown-marron
- n = negro-black-noir
- rs = rosa-pink-rose
- vi = violeta-violet-violette

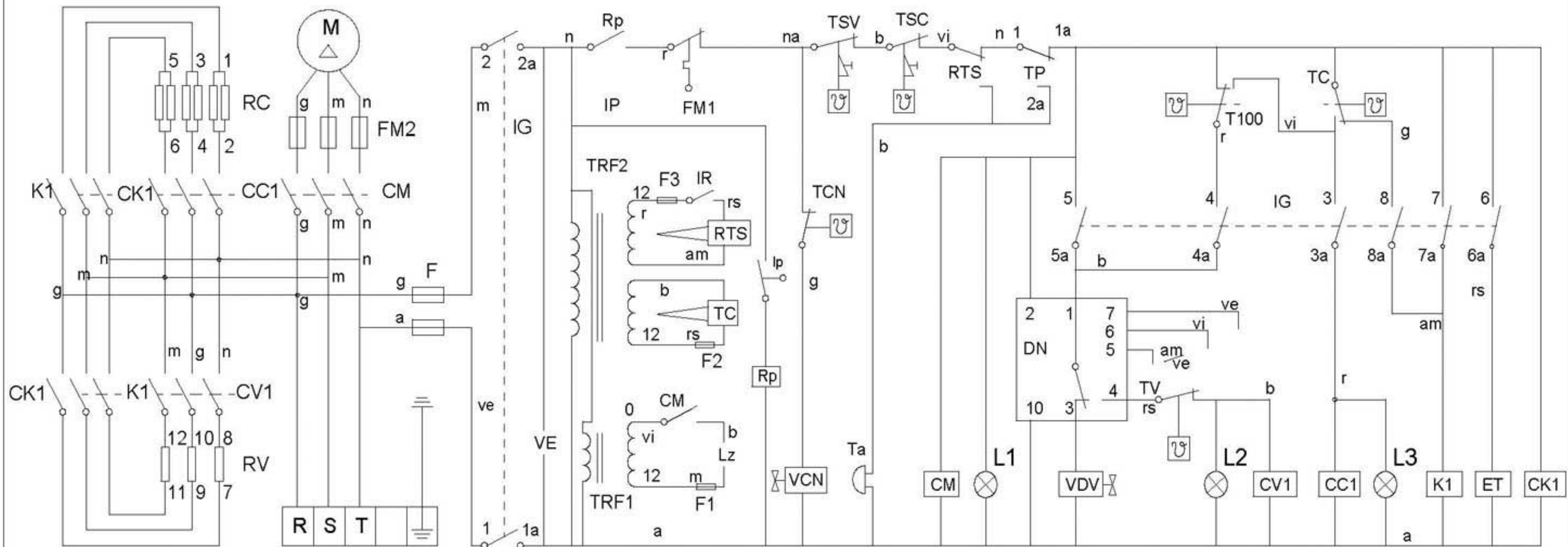

FM2 = Motor fuse
 IP = Door's switch
 IG = General switch
 F = Fuse
 CM = Motor's relay
 VDV = Steamer's solenoid
 DN = Water level control
 FM1 = Motor's thermal protection
 TSV = Steamer's security thermostat
 TSC = Convection's security thermostat
 LZ = Indoor light
 IR = Probe selector
 RTS = Probe controller

RV = Steamer elements
 ET = Chimney solenoid
 VCN = Steamer condenser solenoid
 TC = Convection thermostat
 T100 = 100 °C thermostat
 TV = Steamer's thermostat
 M = Motor
 CC1 = Heating air relays
 CV1 = Heating water relays
 CK1, K1 = Elements relays
 TCN = Steam condenser thermostat
 RC = Heating element
 TRF2= Transformer (Electronic thermostat)

VE = Control panel's fan
 Ta = Alarm
 Tp = Manual Timer
 F1, F2, F3 = Transformer fuse
 TRF1 = Transformer (Indoor light)
 L1 = Pilot lamp (on/off)
 L2 = Pilot lamp (Heating water)
 L3 = Pilot lamp (Heating air)
 Rp = Door's Relay

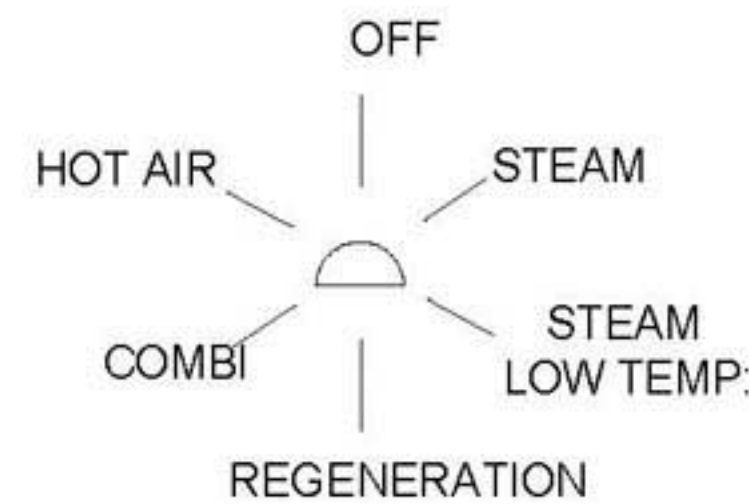

am/ve = amarillo/verde-yellow/green-jaune/vert
 am = amarillo-yellow-jaune
 a = azul-blue-bleu
 b = blanco-white-blanc
 g = gris-grey -gris
 ve = verde-green-vert

na = naranja-orange-orange
 r = rojo-red-rouge
 m = marron-brown-marron
 n = negro-black-noir
 rs = rosa-pink-rose
 vi = violeta-violet-violette

Mode	1 1a	2 2a	3 3a	4 4a	5 5a	6 6a	7 7a	8 8a
OFF								
STEAM	X	X			X		X	
STEAM LOW TEMP	X	X		X				X
REGENERATION	X	X	X	X				X
COMBI	X	X	X	X				
HOT AIR	X	X	X			X	X	

3N~50/60Hz 380/415V

MODELO HMM-10/21 HMM-10/11

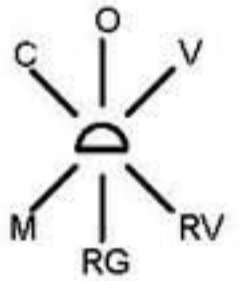
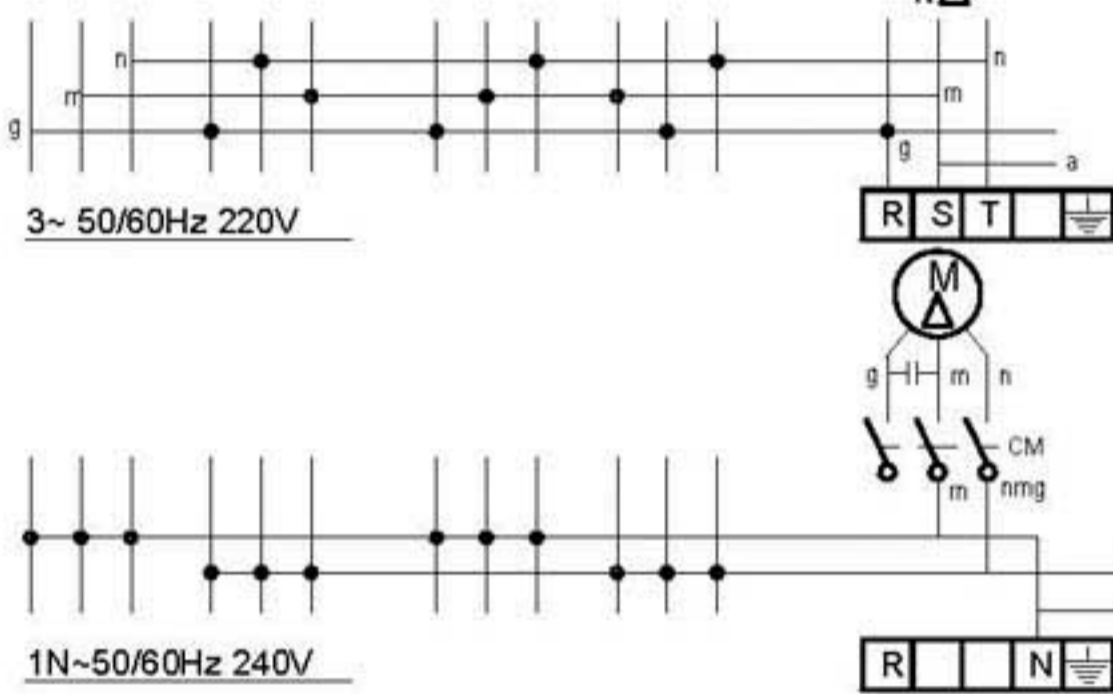
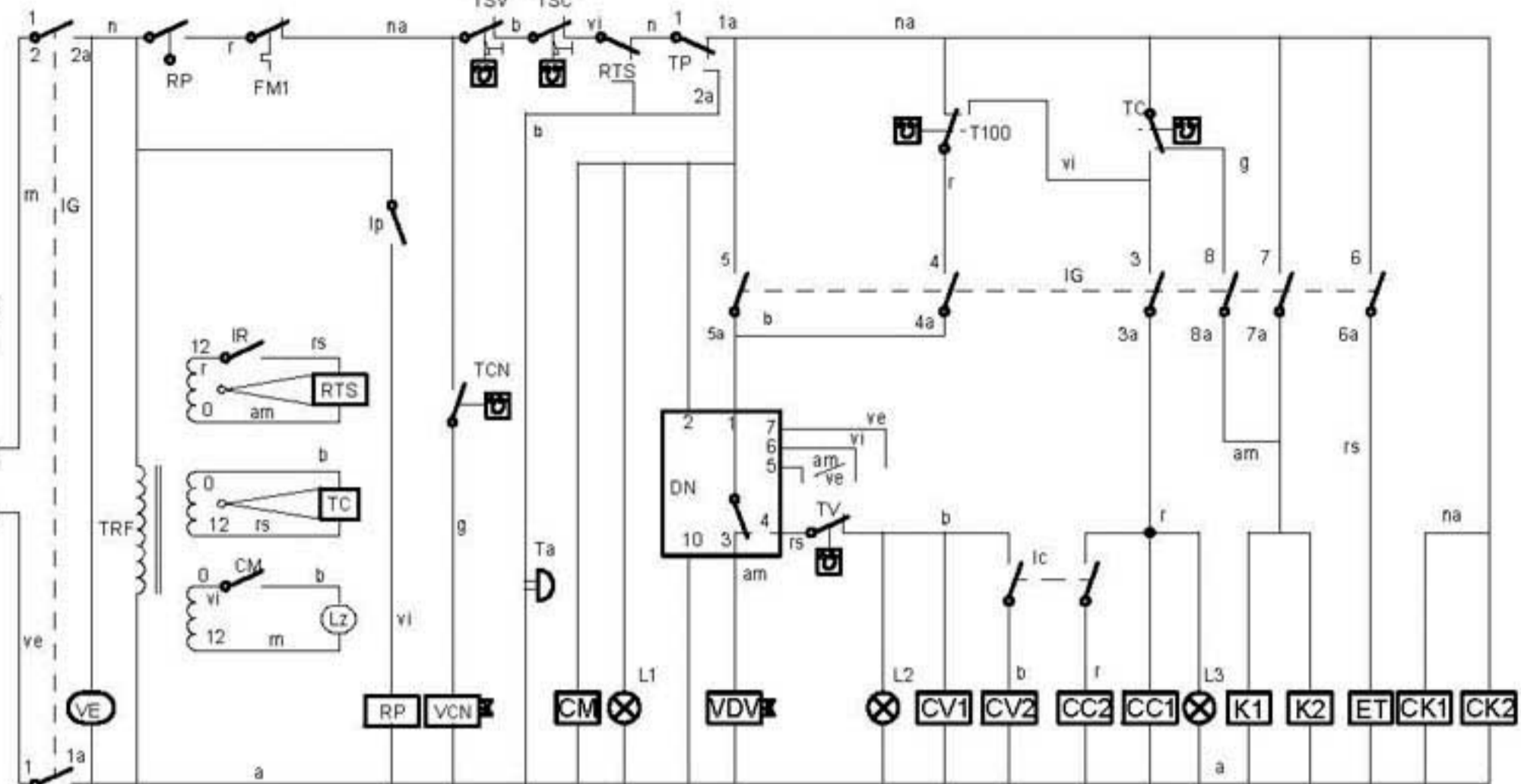
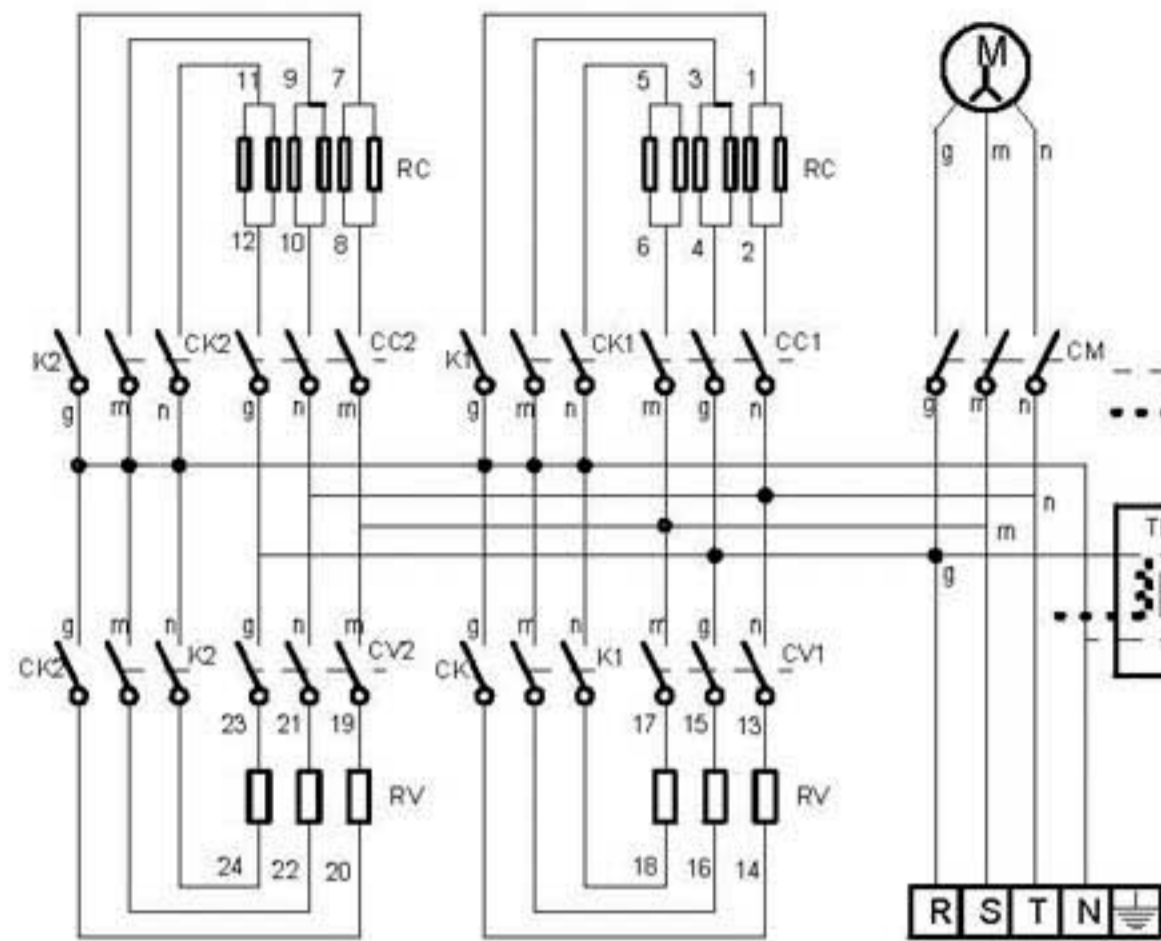

Mode	IG	1	2	3	4	5	6	7	8
		1a	2a	3a	4a - 5a	6a	7a	8a	
OFF									
VAPOR		X	X			X		X	
REG. VAPOR		X	X		X			X	
REGENERAC.		X	X	X	X				X
MIXTO		X	X	X	X				
CONVECCION		X	X	X			X	X	

r = rojo-red-rouge
 m = marron-brown-marron
 g = gris-grey-gris
 n = negro-black-noir
 a = azul-blue-bleu
 b = blanco-white-blanc

vi = violeta-violette-violet
 am = amarillo-yellow-jaune
 na = naranja-orange-orange
 rs = rosa-rose-pink
 ve = verde-green-vert
 am/ve = amarillo/verde-yellow/green-jaune/vert

R-753013

- IP = Interruptor puerta
- IG = Interruptor general
- F = Fusible
- CM = Contactor motor
- VDV = Electroválvula calderin
- DN = Detector de nivel
- FM1 = Térmico motor
- Tsv = Termostato seguridad vapor
- Tsc = Termostato seguridad cámara
- Lz = Luz interior
- IR = Selector regulador sonda nucleo
- RTS = Regulador temperatura sonda nucleo
- RV = Resistencias vapor
- VE = Ventilador cuadro eléctrico
- Ta = Timbre avisador
- Tp = Temporizador
- Rp: Relé puerta
- ET = Electroimán de apertura de tiro
- Ic = Selector de potencia
- VCN = Electroválvula de condensación de vapor
- TC = Termostato cámara
- T100 = Termostato fijo 100°C
- TV = Termostato vapor
- M1 = Motor
- CC1 CC2 = Contactor resistencia cámara
- CV1 CV2 = Contactor resistencia vapor
- CK1, Ck2, K1, K2 = Relé resistencias
- TCN = Termostato de condensacion de vapor
- RC = Resistencias cámara
- TRF = Transformador
- L1 = Lámpara de funcionamiento
- L2 = Lámpara de calentamiento vapor
- L3 = Lámpara de calentamiento cámara

MEDIDAS 225X127

		3~ 50/60Hz 220V			
Esquema teórico adhesivo		3N~ 50/60Hz 380/415V		R-753013	4
Nº	Pieza	Cant.	Material	Nº Clasificacion	Acabado
Nº	Modificacion	Propuesta de		Fecha	Tolerancias generales
1	Introducir RP	Maillo		25/2/2002	<5± : 50-100± : 5-25± : >100± : 25-50± : X± :
Dibujado		Firma	Fecha	Mecanizado superficial	
Proyectado		KONTXI	11/9/98	FAGOR	
Comprobado		Fagor Industrial, Koop Elk, Mugatua		Plano numero	
Escala		HORNO MIXTO HMM			HC-73219 -1
Plano hau ez daitake erabil ez berrita gure baimenitiz gabe					
Sustituye al Nº					
Sustituido por					

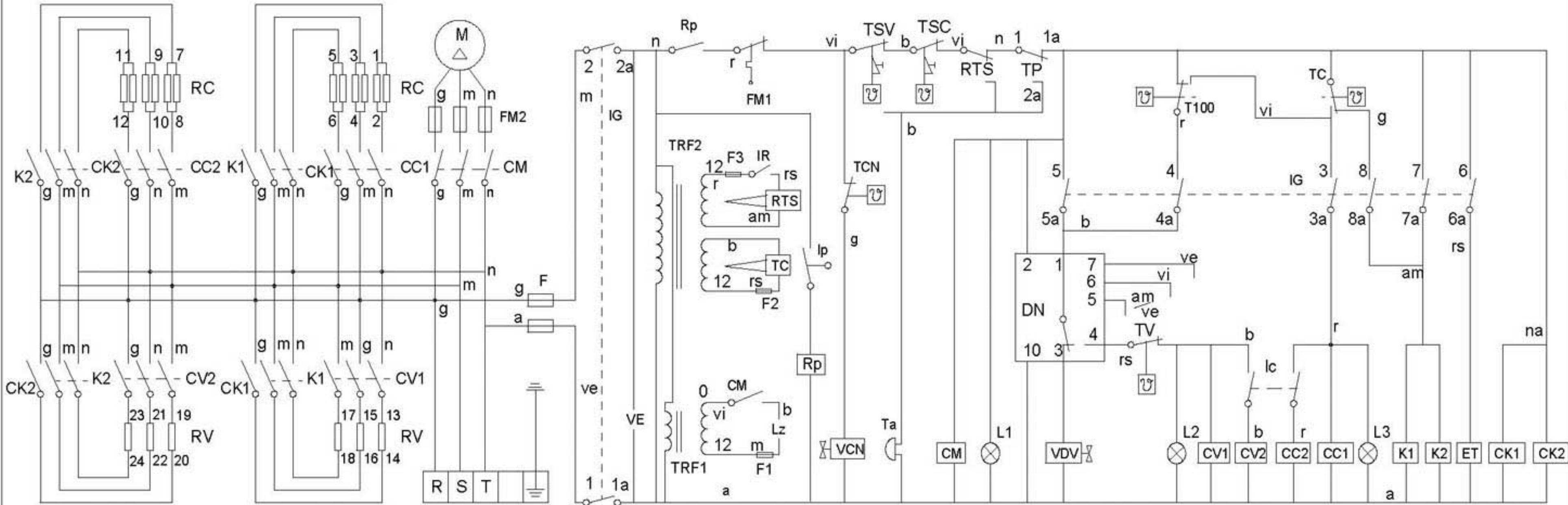

FM2 = Motor fuse

IP = Door's switch

IG = General switch

F = Fuse

CM = Motor's relay

VDV = Steamer's solenoid

DN = Water level control

FM1 = Motor's thermal protection

TSV = Steamer's security thermostat

TSC = Convection's security thermostat

LZ = Indoor light

IR = Probe selector

RTS = Probe controller

RV = Steamer elements

ET = Chimney solenoid

Ic = Power reduction switch

VCN = Steamer condenser solenoid

TC = Convection thermostat

T100 = 100 °C thermostat

TV = Steamer's thermostat

M = Motor

CC1, CC2 = Heating air relays

CV1, CV2 = Heating water relays

CK1, CK2, K1, K2 = Elements relays

TCN = Steam condenser thermostat

RC = Heating element

TRF2 = Transformer (Electronic thermostat)

VE = Control panel's fan

Ta = Alarm

TP = Manual Timer

F1, F2, F3 = Transformer fuse

TRF1 = Transformer (Indoor light)

L1 = Pilot lamp (on/off)

L2 = Pilot lamp (Heating water)

L3 = Pilot lamp (Heating air)

Rp = Door's Relay

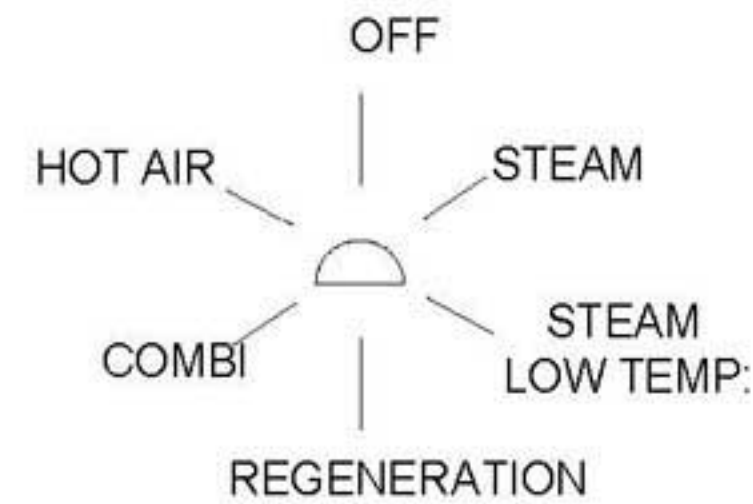

Mode	1 1a	2 2a	3 3a	4 4a	5 5a	6 6a	7 7a	8 8a
OFF								
STEAM	X	X			X		X	
STEAM LOW TEMP	X	X		X			X	
REGENERATION	X	X	X	X				X
COMBI	X	X	X	X				
HOT AIR	X	X	X			X	X	

am/ve = amarillo/verde-yellow/green-jaune/vert

am = amarillo-yellow-jaune

a = azul-blue-bleu

b = blanco-white-blanc

g = gris-grey -gris

ve = verde-green-vert

na = naranja-orange-orange

r = rojo-red-rouge

m = marron-brown-marron

n = negro-black-noir

rs = rosa-pink-rose

vi = violeta-violet-violette

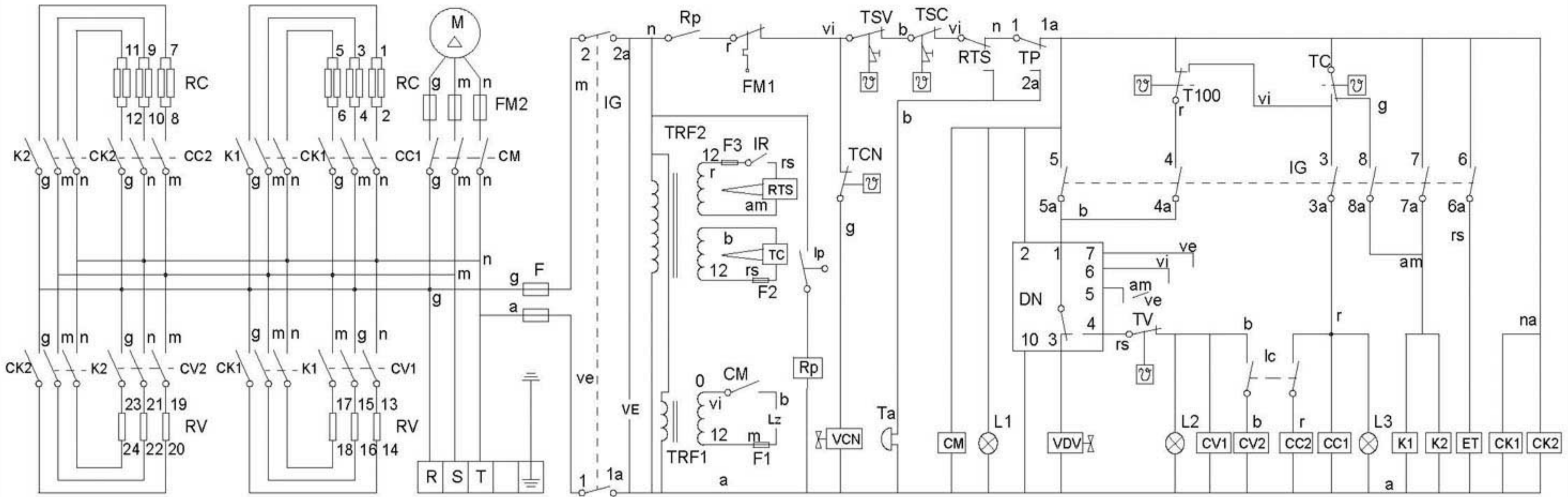

FM2 = Motor fuse
 IP = Door's switch
 IG = General switch
 F = Fuse
 CM = Motor's relay
 VDV = Steamer's solenoid
 DN = Water level control
 FM1 = Motor's thermal protection
 TSV = Steamer's security thermostat
 TSC = Convection's security thermostat
 LZ = Indoor light
 IR = Probe selector
 RTS = Probe controller
 RV = Steamer elements

ET = Chimney solenoid
 Ic = Power reduction switch
 VCN = Steamer condenser solenoid
 TC = Convection thermostat
 T100 = 100 °C thermostat
 TV = Steamer's thermostat
 M = Motor
 CC1, CC2 = Heating air relays
 CV1, CV2 = Heating water relays
 CK1, CK2, K1, K2 = Elements relays
 TCN = Steam condenser thermostat
 RC = Heating element
 TRF2 = Transformer (Electronic thermostat)

VE = Control panel's fan
 Ta = Alarm
 Tp = Manual Timer
 F1, F2, F3 = Transformer fuse
 TRF1 = Transformer (Indoor light)
 L1 = Pilot lamp (on/off)
 L2 = Pilot lamp (Heating water)
 L3 = Pilot lamp (Heating air)
 Rp = Door's Relay

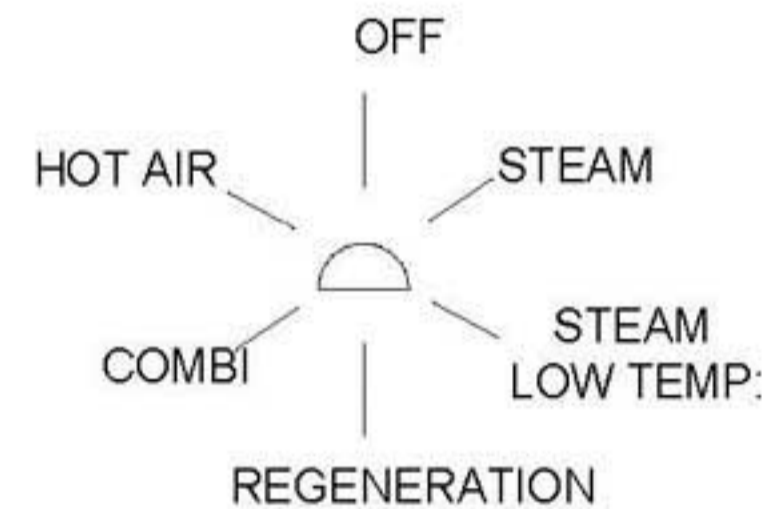

Mode \	1 1a	2 2a	3 3a	4 4a	5-6 5a-6a	7 7a	8 8a
OFF							
STEAM	X	X			X		X
STEAM LOW TEMP	X	X		X			X
REGENERATION	X	X	X	X			X
COMBI	X	X	X	X			
HOT AIR	X	X	X			X	X

am/ve = amarillo/verde-yellow/green-jaune/vert
 am = amarillo-yellow-jaune
 a = azul-blue-bleu
 b = blanco-white-blanc
 g = gris-grey -gris
 ve = verde-green-vert

na = naranja-orange-orange
 r = rojo-red-rouge
 m = marron-brown-marron
 n = negro-black-noir
 rs = rosa-pink-rose
 vi = violeta-violet-violette

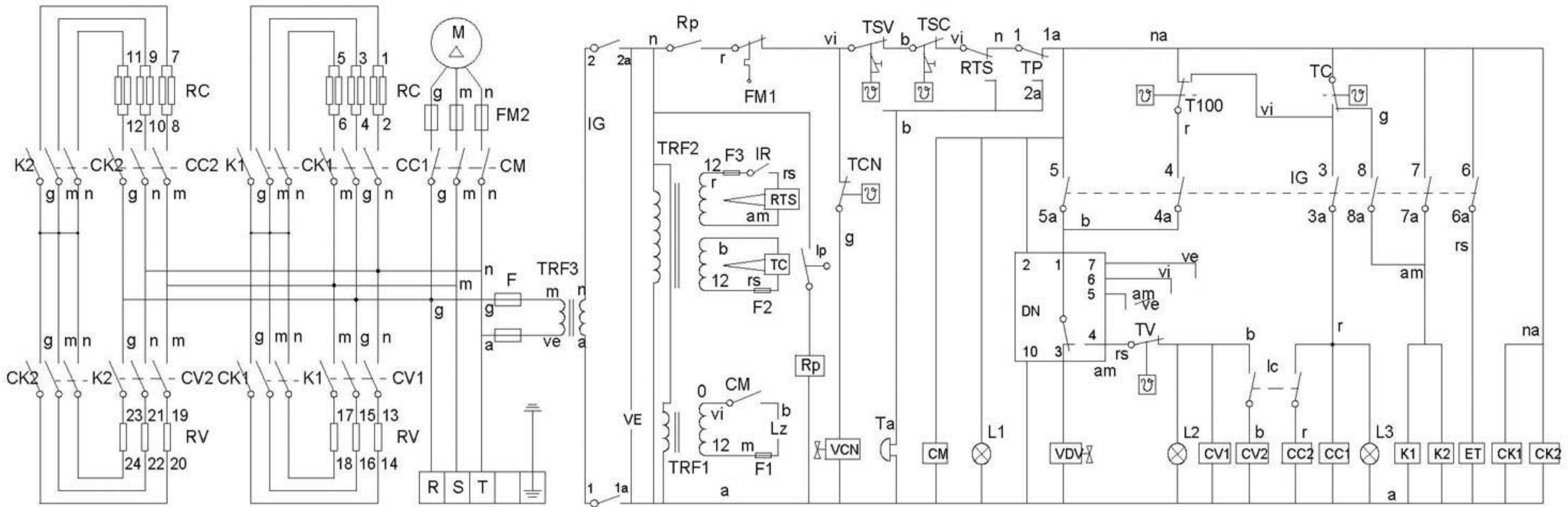

- FM2 = Motor fuse
- IP = Door's switch
- IG = General switch
- F = Fuse
- CM = Motor's relay
- VDV = Steamer's solenoid
- DN = Water level control
- FM1 = Motor's thermal protection
- TSV = Steamer's security thermostat
- TSC = Convection's security thermostat
- LZ = Indoor light
- IR = Probe selector
- RTS = Probe controller
- RV = Steamer elements

- ET = Chimney solenoid
- Ic = Power reduction switch
- VCN = Steamer condenser solenoid
- TC = Convection thermostat
- T100 = 100 °C thermostat
- TV = Steamer's thermostat
- M = Motor
- CC1, CC2 = Heating air relays
- CV1, CV2 = Heating water relays
- CK1, CK2, K1, K2 = Elements relays
- TCN = Steam condenser thermostat
- RC = Heating element
- TRF2 = Transformer (Electronic thermostat)

- VE = Control panel's fan
- Ta = Alarm
- TP = Manual Timer
- F1, F2, F3 = Transformer fuse
- TRF1 = Transformer (Indoor light)
- L1 = Pilot lamp (on/off)
- L2 = Pilot lamp (Heating water)
- L3 = Pilot lamp (Heating air)
- TRF3 = Transformer
- Rp = Door's Relay

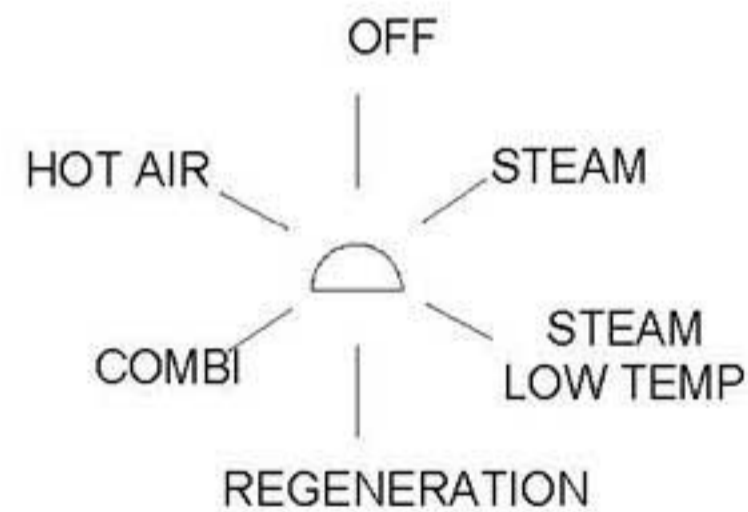

Mode	1 1a	2 2a	3 3a	4 4a	5 5a	6 6a	7 7a	8 8a
OFF								
STEAM	X	X			X		X	
STEAM LOW TEMP	X	X		X			X	
REGENERATION	X	X	X	X				X
COMBI	X	X	X	X				
HOT AIR	X	X	X			X	X	

- am/ve = amarillo/verde-yellow/green-jaune/vert
- am = amarillo-yellow-jaune
- a = azul-blue-bleu
- b = blanco-white-blanc
- g = gris-grey -gris
- ve = verde-green-vert

- na = naranja-orange-orange
- r = rojo-red-rouge
- m = marron-brown-marron
- n = negro-black-noir
- rs = rosa-pink-rose
- vi = violeta-violet-violette

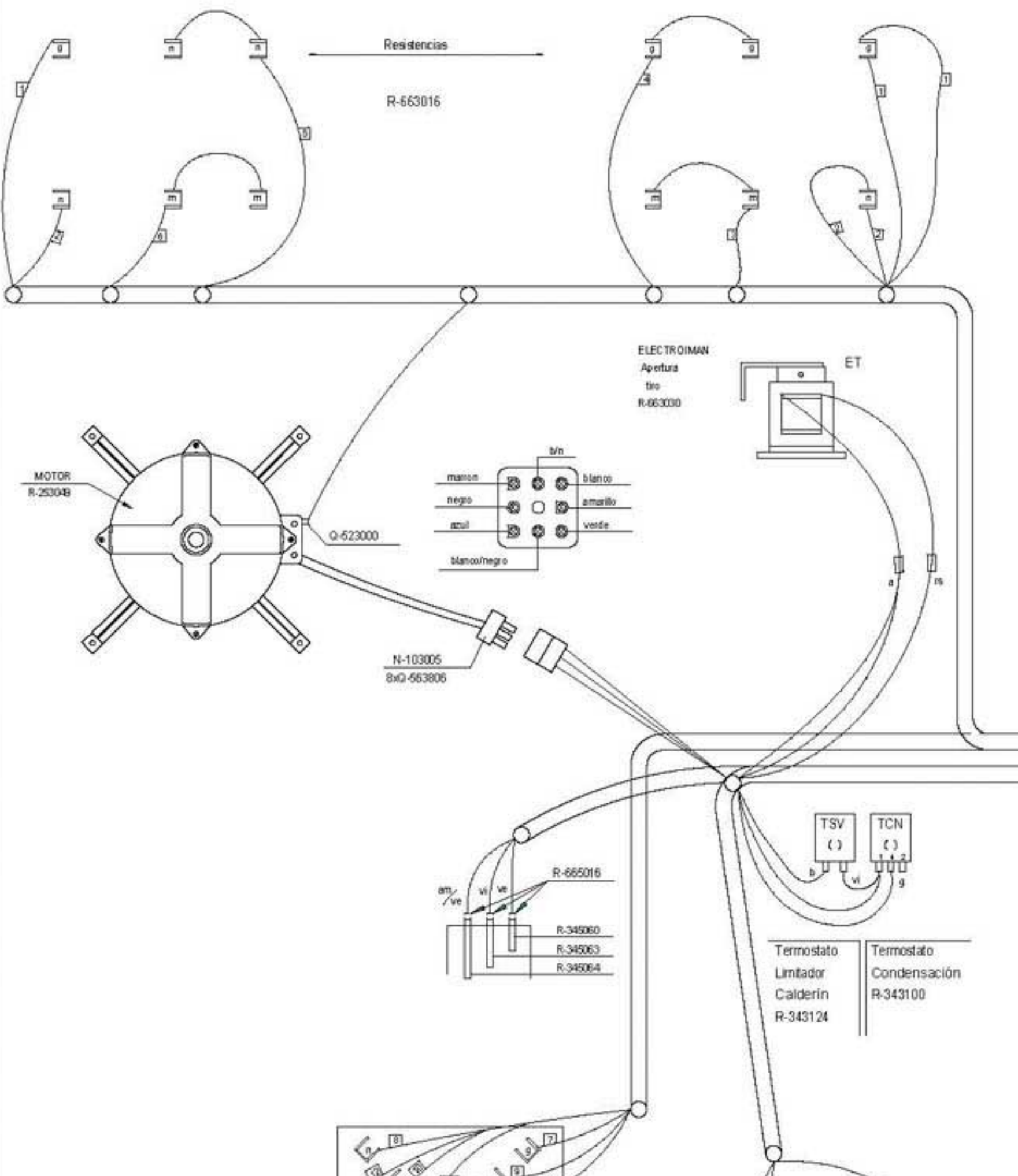

RESISTENCIAS DE GENERADOR R-143000

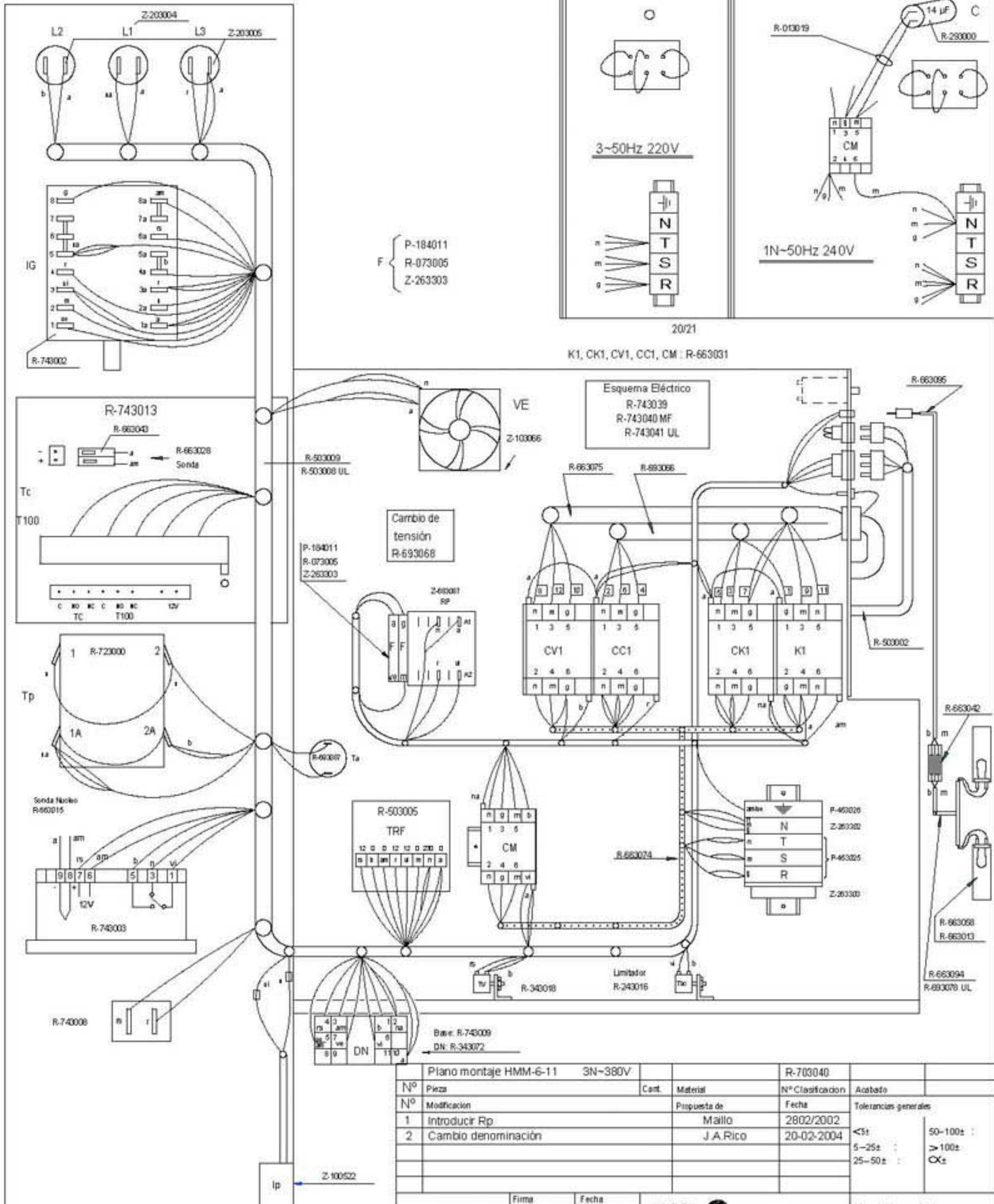
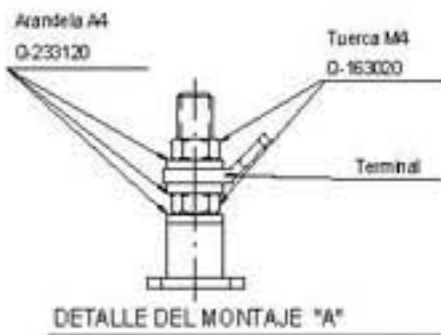

Plano montaje HMM-6-11 3N-380V		R-703040	
Nº Pieza	Cont.	Material	Nº Clasificación
Nº Modificación		Propuesta de	Fecha
1		Maillo	2802/2002
2		J.A.Rico	20-02-2004
Tolerancias generales			
$±5t$		50-100t	
5-25t		> 100t	
25-50t		∞t	

Firma	Fecha		Mezclado superficial
JON	96-10-11		
HORNO MIXTO HMM-6-11			Plano numero HD-12585-02
Escala			Sustituye al N°
Plano has 12 doble e triple e sencillo para hornos mixtos			Sustituido por

