

**Planchas Cafeteria
Grillades Snack
Frytop Snack
Griddleplatten Snack
Frytop Snack**

Gama Cafeteria

Modelos:

PL 105 L

PL 105 C

PL 110 L

PL 110 R

PL 110 L+R

PL 110 C

Diciembre 2002 December

FAGOR 

Fagor Industrial

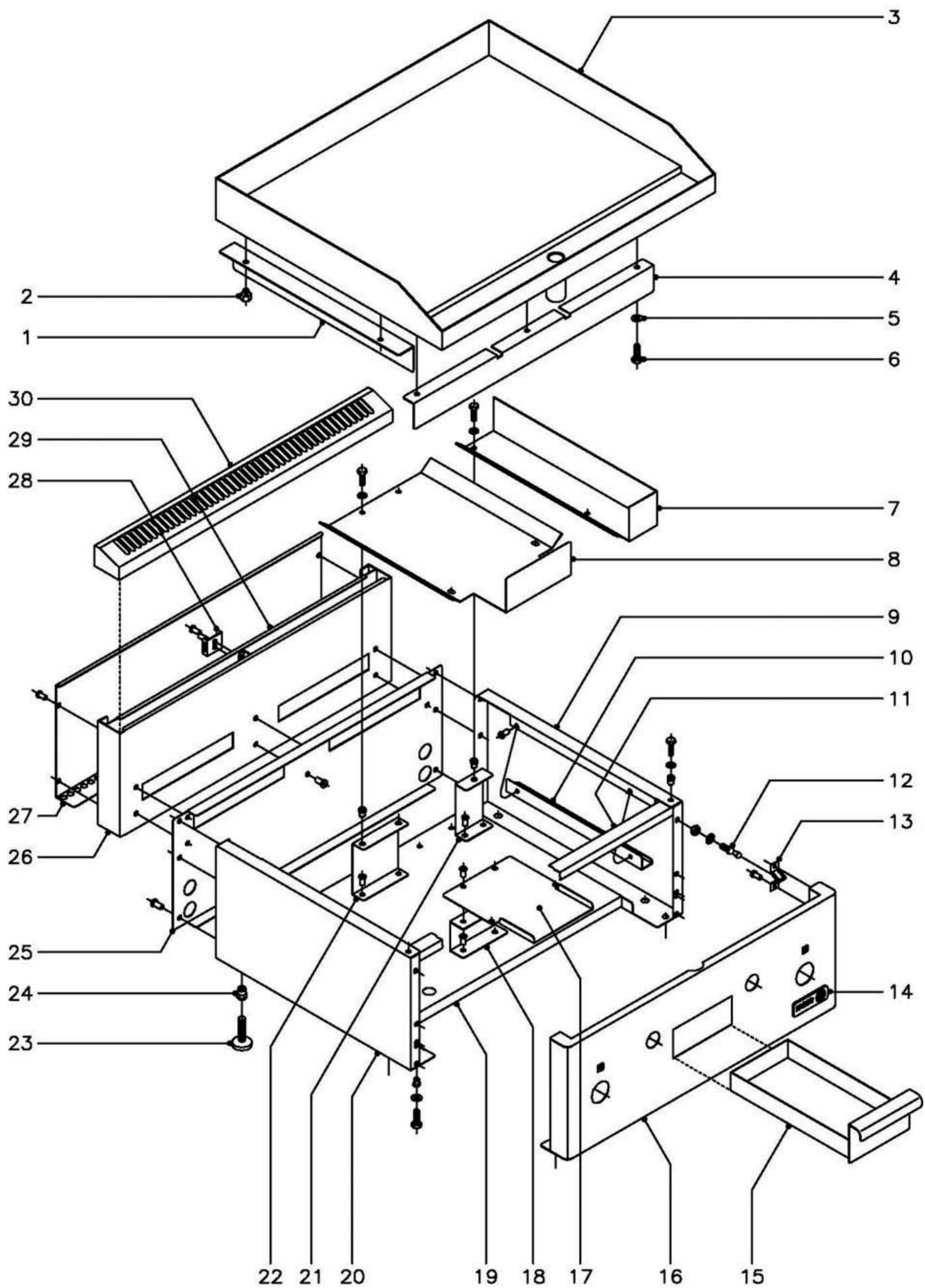

N plano
C-1247

Firma

Fecha
12-2002

Aparato MUEBLE
PLANCHA PL-105, PL-110

Lamina
1

Fagor Industrial S.Coop. **FAGOR**
Date

MOD.		PLANCHAS DE CAFETERIA		ZONA	MUEBLE						PLANO	C-1247	
ITEM	CODIGO	DENOMINACION	TEXTO	PL-105 L	PL-105 C	PL-110 L	PL-110 R	PL-110 L+R	PL-110 C				NOTAS
1	R535416	Liston lateral		2	2	2	2	2	2				
2	R615412	Apoyo lateral		4	4	4	4	4	4				
3	R525400	Plancha de asado (Lisa)		1	-	-	-	-	-				
3	R525405	Plancha de asado (Cromoduro)		-	1	-	-	-	-				
3	R535400	Plancha de asado (Lisa)		-	-	1	-	-	-				
3	R535414	Plancha de asado (Rayada)		-	-	-	1	-	-				
3	R535407	Plancha de asado (Lisa + Rayada)		-	-	-	-	1	-				
3	R535410	Plancha de asado (Cromoduro)		-	-	-	-	-	1				
4	R525408	Faldon frontal		1	-	-	-	-	-				
4	R525407	Faldon frontal		-	1	-	-	-	-				
4	R535417	Faldon frontal		-	-	1	1	1	-				
4	R535415	Faldon frontal		-	-	-	-	-	1				
5	Q302022	Arandela plana Ø16xØ6x1,2		6	6	10	10	10	10				
6	Q012041	Tornillo exagonal M-6x10		3	3	5	5	5	5				
7	R532610	Deflector lateral derecho		1	1	1	1	1	1				
s/n	R532609	Deflector lateral izquierdo		1	1	1	1	1	1				
	Q242030	Arandela abanico A-5		4	4	4	4	4	4				
	Q012031	Tornillo exagonal M-5x10		4	4	4	4	4	4				
8	R532611	Deflector central		1	1	2	2	2	2				
	Q242030	Arandela abanico A-5		4	4	8	8	8	8				
	Q012031	Tornillo exagonal M-5x10		4	4	8	8	8	8				
9	R532801	Panel lateral derecho		1	1	1	1	1	1				
10	R792605	Tirante lateral		2	2	2	2	2	2				
	Q419005	Remache tubular Ø4x8		4	4	4	4	4	4				
11	R522601	Larguero superior		1	1	-	-	-	-				
11	R532606	Larguero superior		-	-	1	1	1	1				
	Q221342	Remache exagonal M-5		2	2	2	2	2	2				
	Q242030	Arandela abanico A-5		2	2	2	2	2	2				
	Q012031	Tornillo exagonal M-5x10		2	2	2	2	2	2				

MOD.

PLANCHAS DE CAFETERIA

ZONA

MUEBLE

PLANO

C-1247

ITEM	CODIGO	DENOMINACION	TEXTO	PL-105 L	PL-105 C	PL-110 L	PL-110 R	PL-110 L+R	PL-110 C				NOTAS
12	X012612	Piton cierre portamandos		2	2	2	2	2	2				
	Q242030	Arandela abanico A-5		2	2	2	2	2	2				
	Q162030	Tuerca exagonal M-5		2	2	2	2	2	2				
13	X010503	Muelle enganche piton		2	2	2	2	2	2				
	Q419007	Remache tubular Ø3,2x6		4	4	4	4	4	4				
14	U262806	Escudo FAGOR		1	1	1	1	1	1				
	Q221023	Clip sujecion escudo		2	2	2	2	2	2				
15	R532604	Caja recoge grasas		1	1	1	1	1	1				
16	R522804	Panel portamandos 105		1	1	-	-	-	-				
16	R532806	Panel portamandos 110		-	-	1	1	1	1				
	Q221342	Remache exagonal M-5		2	2	2	2	2	2				
	Q302022	Arandela plana Ø16xØ6x1,2		2	2	2	2	2	2				
	Q012031	Tornillo exagonal M-5x10		2	2	2	2	2	2				
17	R532603	Guia recoge grasas		1	1	1	1	1	1				
	Q419005	Remache tubular Ø4x8		4	4	4	4	4	4				
18	R532602	Apoyo recoge grasas		1	1	1	1	1	1				
	Q419005	Remache tubular Ø4x8		2	2	2	2	2	2				
19	R522600	Base PL-105		1	1	-	-	-	-				
19	R532601	Base PL-110		-	-	1	1	1	1				
	Q221342	Remache exagonal M-5		4	4	4	4	4	4				
	Q242030	Arandela abanico A-5		4	4	4	4	4	4				
	Q012031	Tornillo exagonal M-5x10		4	4	4	4	4	4				
20	R532800	Panel lateral izquierdo		1	1	1	1	1	1				
21	R532607	Soporte deflector lateral		2	2	2	2	2	2				
	Q221342	Remache exagonal M-5		2	2	2	2	2	2				
	Q419005	Remache tubular Ø4x8		4	4	4	4	4	4				
22	R532613	Soporte deflector central		1	1	2	2	2	2				
	Q221342	Remache exagonal M-5		2	2	4	4	4	4				
	Q419005	Remache tubular Ø4x8		2	2	4	4	4	4				

MOD.

PLANCHAS DE CAFETERIA

ZONA

MUEBLE

PLANO

C-1247

ITEM	CODIGO	DENOMINACION	TEXTO	PL-105 L	PL-105 C	PL-110 L	PL-110 R	PL-110 L+R	PL-110 C				NOTAS
23	Z200105	Pata regulable		4	4	4	4	4	4				
24	Q221345	Remache exagonal M-10		4	4	4	4	4	4				
25	R522801	Panel posterior PL-105		1	1	-	-	-	-				
25	R532803	Panel posterior PL-110		-	-	1	1	1	1				
	Q419005	Remache tubular Ø4x8		6	6	6	6	6	6				
26	R522802	Anterior de chimenea PL-105		1	1	-	-	-	-				
26	R532804	Anterior de chimenea PL-110		-	-	1	1	1	1				
	Q419005	Remache tubular Ø4x8		6	6	8	8	8	8				
27	R522803	Posterior de chimenea PL-105		1	1	-	-	-	-				
27	R532805	Posterior de chimenea PL-110		-	-	1	1	1	1				
	Q419005	Remache tubular Ø4x8		4	4	4	4	4	4				
28	R202604	Escuadra separador de chimenea		2	2	2	2	2	2				
	Q419005	Remache tubular Ø4x8		2	2	2	2	2	2				
29	R522602	Separador de chimenea PL-105		1	1	-	-	-	-				
29	R532608	Separador de chimenea PL-110		-	-	1	1	1	1				
30	R525404	Embellecador posterior PL-105		1	1	-	-	-	-				
30	R535406	Embellecador posterior PL-110		-	-	1	1	1	1				

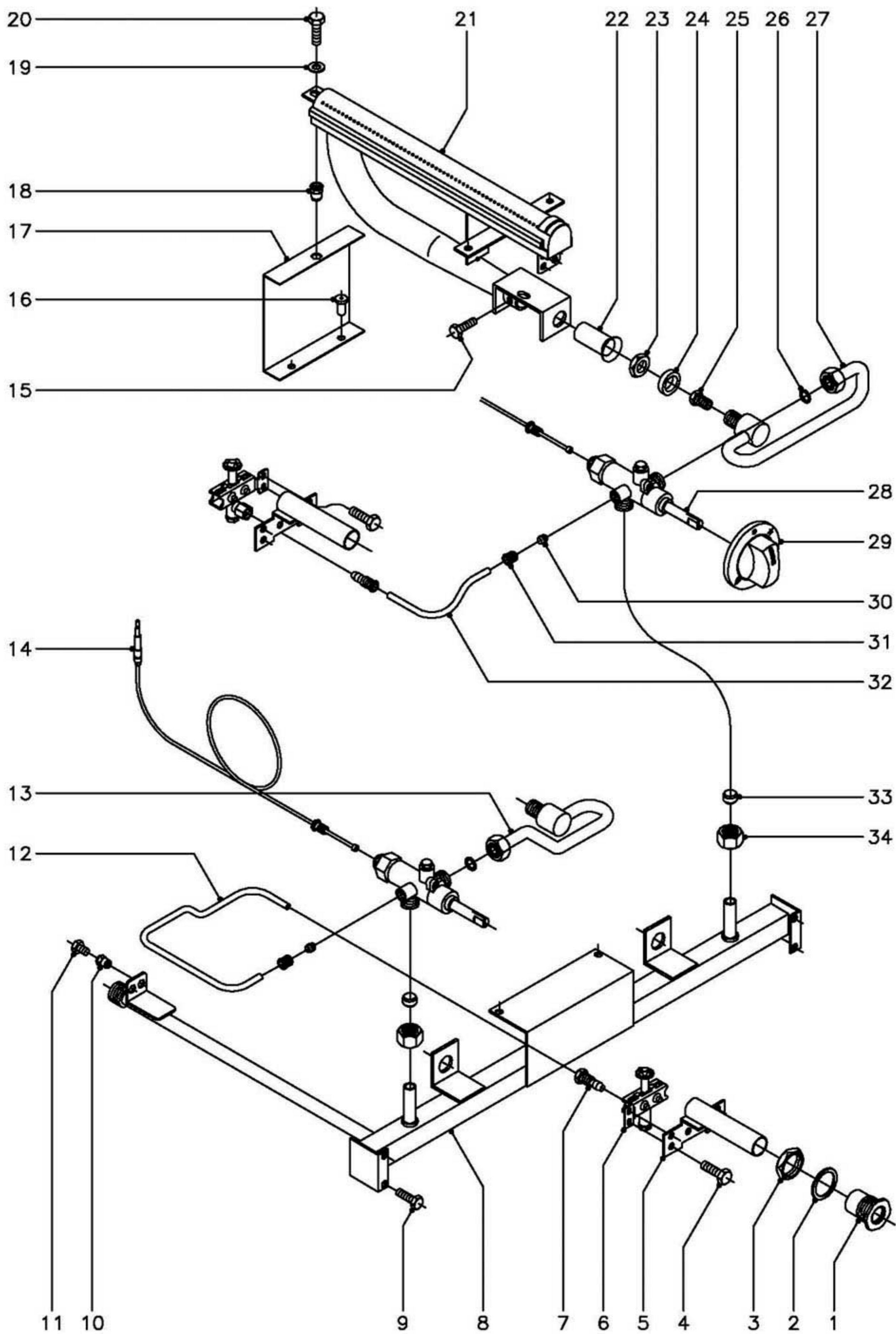

N plano
C-1248

Firma

Fecha
12-2002

Aparato
PLANCHA PL-105L,R, PL-110L,R

PARTE FUNCIONAL

Lamina
2

Fagor Industrial S.Coop. **FAGOR**
Onate

MOD.		PLANCHAS DE CAFETERIA		ZONA		PARTE FUNCIONAL						PLANO		C-1248	
ITEM	CODIGO	DENOMINACION	TEXTO	PL-105 L	PL-110 L Y R									NOTAS	
1	S112804	Embellecedor tubo encendido		2	3										
2	Q306027	Arandela junta Ø33,8xØ27x1,5		2	3										
3	Q221324	Tuerca exagonal 3/4"		2	3										
4	Q012031	Tornillo exagonal M-5x10		4	6										
5	R535014	Tubo de encendido		2	3										
6	U322118	Piloto completo		2	3										
	U442138	Inyector piloto Ø0,25 (B.P. y G.V.)		2	3									Regular para Gas Villa	
	U442137	Inyector piloto Ø0,40 (G.N.)		2	3										
7	U134323	Racord con bicono Ø6		2	3										
8	R525020	Conduccion general PL-105		1	-										
8	R535049	Conduccion general PL-110		-	1										
9	Q012031	Tornillo exagonal M-5x10		4	4										
10	Q221342	Remache exagonal M-5		1	1										
11	Q012031	Tornillo exagonal M-5x10		1	1										
12	R535041	Tubo piloto izquierdo		1	1										
13	R535043	Conduccion a quemador izquierdo		1	1										
14	U222130	Termopar L=600		2	3										
15	Q012031	Tornillo exagonal M-5x10		2	3										
16	Q419005	Remache tubular Ø4x8		4	6										
17	R532600	Soporte quemador		2	3										
18	Q221342	Remache exagonal M-5		2	3										
19	Q302022	Arandela plana Ø16xØ6x1,2		2	3										
20	Q012031	Tornillo exagonal M-5x10		2	3										
21	R535700	Quemador		2	3										
22	U325707	Regulador de aire		2	3										
23	Q223019	Tuerca exagonal 3/8"		2	3										
24	Q301323	Arandela Ø25xØ17x6		2	3										
25	U149402	Tobera Ø1,00 (B.P.)		2	3										
25	U112401	Tobera Ø1,55 (G.N.)		2	3										

MOD.**PLANCHAS DE CAFETERIA****ZONA****PARTE FUNCIONAL****PLANO****C-1248****ITEM****CODIGO****DENOMINACION****TEXTO****PL-105 L****PL-110 L Y R****NOTAS**

25

R532400

Tobera Ø3,2 (G.V.)

2

3

26

Q306055

Arandela junta Ø13,9xØ10,3x1

2

3

27

R535047

Conduccion a quemador derecho

1

2

28

U249401

Grifo CAL-3200 (min.-0,55)

2

3

29

U542101

Boton de mando Ø10

2

3

30

X205028

Bicono Ø6

2

3

31

U195009

Manguito empalme 1/8" (p/tubo Ø6)

2

3

32

R535045

Tubo piloto derecho

1

2

33

U055043

Bicono Ø12

2

3

34

Q221336

Tuerca M-18x1,5 (para tubo Ø12)

2

3

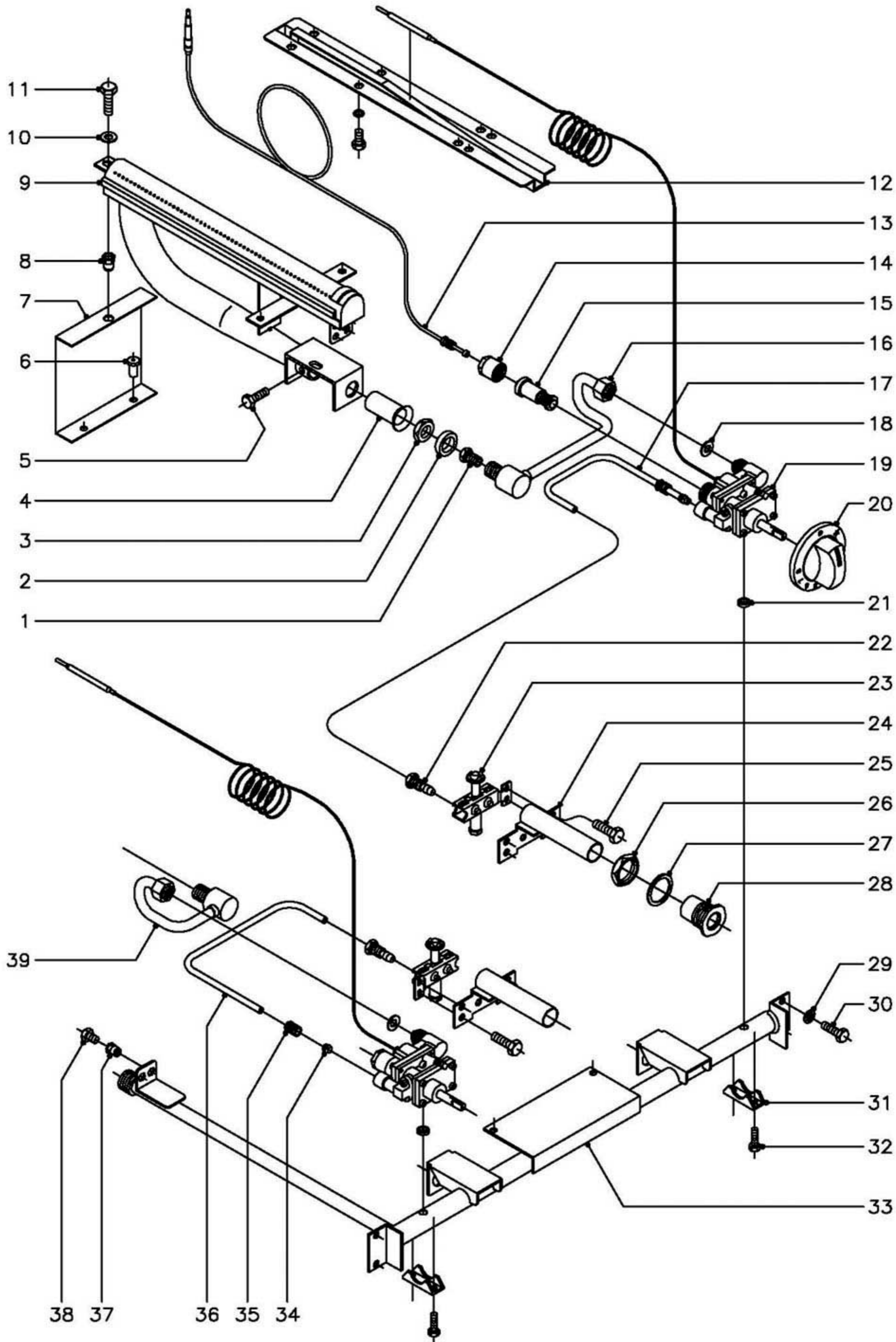

N plano	Firma	Fecha	Aparato	PARTE FUNCIONAL	Lamina	Fagor Industrial S.Coop. FAGOR
C-1249		12-2002	PLANCHA PL-105 C, PL-110 C		3	Oficinas

MOD.		PLANCHAS DE CAFETERIA		ZONA	PARTE FUNCIONAL							PLANO	C-1249
ITEM	CODIGO	DENOMINACION	TEXTO	PL-105 C	PL-110 C							NOTAS	
1	U149402	Tobera Ø1,00 (B.P.)		2	3								
1	U112401	Tobera Ø1,55 (G.N.)		2	3								
1	R532400	Tobera Ø3,2 (G.V.)		2	3								
2	Q301323	Arandela Ø25xØ17x6		2	3								
3	Q223019	Tuerca exagonal 3/8"		2	3								
4	U325707	Regulador de aire		2	3								
5	Q012031	Tornillo exagonal M-5x10		2	3								
6	Q419005	Remache tubular Ø4x8		4	6								
7	R532600	Soporte quemador		2	3								
8	Q221342	Remache exagonal M-5		2	3								
9	R535700	Quemador		2	3								
10	Q302022	Arandela plana Ø16xØ6x1,2		2	3								
11	Q012031	Tornillo exagonal M-5x10		2	3								
12	R162630	Conjunto soporte bulbo		2	3								
	Q012041	Tornillo exagonal M-6x10		4	6								
	Q262040	Arandela muelle A-6		4	6								
13	U222130	Termopar L=600		2	3								
14	6002706	Tapon grupo electromagnetico		2	3								
15	6002705	Grupo electromagnetico		2	3								
16	R535053	Conduccion a quemador derecho		1	2								
17	R535058	Tubo piloto derecho		1	2								
18	Q306026	Arandela junta Ø14xØ8,5x1,5		2	3								
19	R532103	Termostato MTZ-7200 (min.-0,60)		2	3								
20	R202106	Boton de mando Ø8		2	3								
21	Q307034	Junta estanqueidad termostato		2	3								
22	U134323	Racord con bicono Ø6		2	3								
23	U322118	Piloto completo		2	3								
	U442138	Inyector piloto Ø0,25 (B.P. y G.V.)		2	3							Regular para Gas Villa	
	U442137	Inyector piloto Ø0,40 (G.N.)		2	3								

ITEM	CODIGO	DENOMINACION	TEXTO	PL-105 C	PL-110 C								NOTAS
24	R535014	Tubo de encendido		2	3								
25	Q012031	Tornillo exagonal M-5x10		4	6								
26	Q221324	Tuerca exagonal 3/4"		2	3								
27	Q306027	Arandela junta Ø33,8xØ27x1,5		2	3								
28	S112804	Embellecedor tubo encendido		2	3								
29	Q242030	Arandela abanico A-5		4	4								
30	Q012031	Tornillo exagonal M-5x10		4	4								
31	Z982018	Brida amarre termostato		2	3								
32	Q151317	Tornillo exagonal M-5x22		4	6								
33	R525022	Conduccion general PL-105C		1	-								
33	R535051	Conduccion general PL-110C		-	1								
34	X205028	Bicono Ø6		2	3								
35	U195009	Manguito empalme 1/8" (p/tubo Ø6)		2	3								
36	R535029	Tubo piloto izquierdo		1	1								
37	Q221342	Remache exagonal M-5		1	1								
38	Q012031	Tornillo exagonal M-5x10		1	1								
39	R535025	Conduccion a quemador izquierdo		1	1								

MOD.

PLANCHAS DE CAFETERIA

ZONA

VARIOS

PLANO

ITEM

CODIGO

DENOMINACION

TEXTO

PL-105 L

PL-105 C

PL-110 L

PL-110 R

PL-110 L+R

PL-110 C

NOTAS

R536500 Folleto de instrucciones

1

1

1

1

1

1

R636500 Rasqueta Martor

-

1

-

-

-

1

MOD.

PLANCHAS DE CAFETERIA

ZONA

PIEZAS ESPECIFICAS PARA LOS DISTINTOS GASES

PLANO

ITEM	CODIGO	DENOMINACION	TEXTO	PL-105	PL-110														NOTAS
		<u>BUTANO - PROPANO</u>																	
	U149402	Tobera quemador Ø1,00		2	3														
	U442138	Inyector piloto Ø0,25		2	3														
		<u>GAS NATURAL</u>																	
	U112401	Tobera quemador Ø1,55		2	3														
	U442137	Inyector piloto Ø0,40		2	3														
		<u>GAS VILLA</u>																	
	R532400	Tobera quemador Ø3,2		2	3														
	U442138	Inyector piloto Ø0,25		2	3														Regular para Gas Villa

MOD.

PLANCHAS DE CAFETERIA
AZKOYEN

ZONA

PIEZAS ESPECIFICAS PARA AZKOYEN

PLANO

ITEM

CODIGO

DENOMINACION

TEXTO

PAG-65/L

* PL-105 L

PAG-65/CD

* PL-105 C

NOTAS

U506530

Escudo AZKOYEN

1

1

Z208610

Hoja de garantia AZKOYEN

1

1

* MODELO EQUIVALENTE FAGOR

MOD.

PLANCHAS DE CAFETERIA
ASPES

ZONA

PIEZAS ESPECIFICAS PARA ASPES

PLANO

ITEM

CODIGO

DENOMINACION

TEXTO

PAG-60L

* PL-105 L

PAG-60C

* PL-105 C

NOTAS

U262831

Escudo ASPES

1

1

U542131

Boton de mando Ø10 ASPES

2

2

*** MODELO EQUIVALENTE FAGOR**