

Sarten basculante
Sauteuse basculante
Tilting bratt pan
Kippbratpfannen
Brasiera

SERIE 900

Modelos:

SBG 9-10
SBG 9-10S
SBG 9-10I
SBG 9-10 I S
SBG 9-10 M
SBG 9-10 M S
SBG 9-10 I M
SBG 9-10 I M S
SBG 9-15 I M
SBG 9-15 I M S

SBE 9-10
SBE 9-10S
SBE 9-10I
SBE 9-10 I S
SBE 9-10 M
SBE 9-10 M S
SBE 9-10 I M
SBE 9-10 I M S
SBE 9-15 I M
SBE 9-15 I M S

Junio 2002 June

FAGOR 

Fagor Industrial

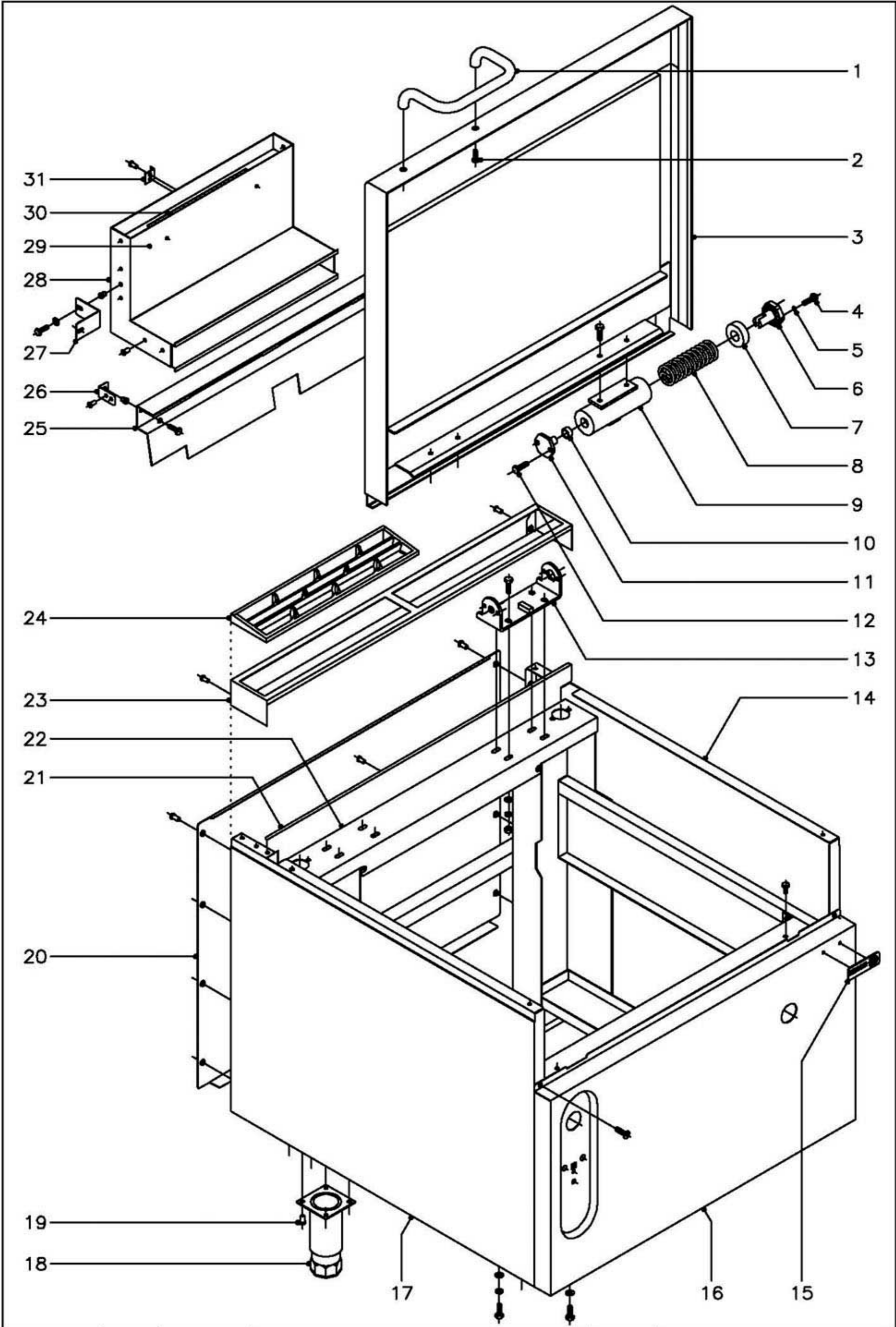

MOD.

SARTENES BASCULANTES GAMA 900

ZONA

MUEBLE

PLANO

C-1197

ITEM	CODIGO	DENOMINACION	TEXTO	SBG9-10	SBG9-10 M	SBG9-10 S	SBG9-10 M S	SBE9-10	SBE9-10 M	SBE9-10 S	SBE9-10 M S	SBG9-15 M	SBG9-15 M S	SBE9-15 M	SBE9-15 M S	NOTAS
1	S036123	Asa de tapa		1	1	1	1	1	1	1	1	1	1	1	1	
2	X152809	Tornillo sujecion asa tapa M-8x15		2	2	2	2	2	2	2	2	2	2	2	2	
3	X152843	Tapa completa 1 M.		1	1	1	1	-	-	-	-	-	-	-	-	
3	X282820	Tapa completa 1,5 M.		-	-	-	-	1	1	1	1	1	1	1	1	
4	Q012042	Tornillo exagonal M-6x15		4	4	4	4	4	4	4	4	4	4	4	4	
5	Q262040	Arandela muelle A-6		4	4	4	4	4	4	4	4	4	4	4	4	
6	S116120	Tensor resorte		2	2	2	2	2	2	2	2	2	2	2	2	
7	S116118	Casquillo		2	2	2	2	2	2	2	2	2	2	2	2	
8	S116121	Resorte tapa		2	2	2	2	2	2	2	2	2	2	2	2	
9	X156101	Bisagra		2	2	2	2	2	2	2	2	2	2	2	2	
	Q012051	Tornillo exagonal M-8x10		4	4	4	4	4	4	4	4	4	4	4	4	
10	S116126	Cojinete cilindrico		2	2	2	2	2	2	2	2	2	2	2	2	
11	S116119	Giro de asa		2	2	2	2	2	2	2	2	2	2	2	2	
12	Q012041	Tornillo exagonal M-6x10		4	4	4	4	4	4	4	4	4	4	4	4	
13	X286102	Soporte de bisagra		2	2	2	2	2	2	2	2	2	2	2	2	
	Q012053	Tornillo exagonal M-8x20		8	8	8	8	8	8	8	8	8	8	8	8	
	Q232050	Arandela plana A-8		8	8	8	8	8	8	8	8	8	8	8	8	
	Q262050	Arandela muelle A-8		8	8	8	8	8	8	8	8	8	8	8	8	
	Q162050	Tuerca exagonal M-8		8	8	8	8	8	8	8	8	8	8	8	8	
14	X152836	Panel lateral derecho		1	-	1	-	1	-	1	-	1	-	1	-	
14	X242820	Panel lateral derecho suspendido		-	1	-	1	-	1	-	1	-	1	-	1	
	Q012042	Tornillo exagonal M-6x15		4	4	4	4	4	4	4	4	4	4	4	4	
	Q262040	Arandela muelle A-6		4	4	4	4	4	4	4	4	4	4	4	4	
	Q302022	Arandela plana Ø16xØ6x1,2		4	4	4	4	4	4	4	4	4	4	4	4	
15	U262806	Escudo FAGOR		1	1	1	1	1	1	1	1	1	1	1	1	
	Q221023	Clip sujecion escudo		2	2	2	2	2	2	2	2	2	2	2	2	
16	X152839	Panel frontal SBG9-10		1	1	-	-	-	-	-	-	-	-	-	-	
16	X342805	Panel frontal SBG9-10 Motorizada		1	1	-	-	-	-	-	-	-	-	-	-	
16	X142802	Panel frontal SBE9-10		-	-	1	1	-	-	-	-	-	-	-	-	

MOD.

SARTENES BASCULANTES GAMA 900

ZONA

MUEBLE

PLANO

C-1197

ITEM	CODIGO	DENOMINACION	TEXTO	SBG9-10		SBE9-10		SBG9-15		SBE9-15			NOTAS
				M	S	M	S	M	S	M	S		
16	X142802	Panel frontal SBE9-10 Motorizada		-	-	1	1	-	-	-	-		
16	X282816	Panel frontal SBG-15		-	-	-	-	1	1	-	-		
16	X422801	Panel frontal SBE-15		-	-	-	-	-	-	1	1		
	Q012042	Tornillo exagonal M-6x15		2	2	2	2	2	2	2	2		
	Q262040	Arandela muelle A-6		2	2	2	2	2	2	2	2		
	Q152004	Tornillo aplastado M-5x13		2	2	2	2	2	2	2	2		
17	X152835	Panel lateral izquierdo		1	-	1	-	1	-	1	-		
17	X242821	Panel lateral izquierdo suspendido		-	1	-	1	-	1	-	1		
	Q012042	Tornillo exagonal M-6x15		4	4	4	4	4	4	4	4		
	Q262040	Arandela muelle A-6		4	4	4	4	4	4	4	4		
	Q302022	Arandela plana Ø16xØ6x1,2		4	4	4	4	4	4	4	4		
18	X260151	Pata regulable		4	-	4	-	4	-	4	-		
19	Q411304	Remache avibulb Ø4,8		16	-	16	-	16	-	16	-		
20	U562853	Panel posterior SB-10		1	-	1	-	-	-	-	-		
20	S372816	Panel posterior SB-10 suspendido		-	1	-	1	-	-	-	-		
20	U582852	Panel posterior SB-15		-	-	-	-	1	-	1	-		
20	X412802	Panel posterior SB-15 suspendido		-	-	-	-	-	1	-	1		
	Q419005	Remache tubular Ø4x8		8	8	8	8	8	8	8	8		
21	X152638	Liston posterior SB-10		1	1	1	1	-	-	-	-		
21	X282613	Liston posterior SB-15		-	-	-	-	1	1	1	1		
	Q419005	Remache tubular Ø4x8		5	5	5	5	5	5	5	5		
22	X150100	Armazon completo SB-10		1	-	1	-	-	-	-	-		
22	X240100	Armazon completo SB-10 S		-	1	-	1	-	-	-	-		
22	X420100	Armazon completo SB-15		-	-	-	-	1	-	1	-		
22	X440100	Armazon completo SB-15 S		-	-	-	-	-	1	-	1		
23	R205428	Soporte embellecedor 1 M.		1	1	1	1	-	-	-	-		
23	R205430	Soporte embellecedor 1,5 M.		-	-	-	-	1	1	1	1		
	Q419005	Remache tubular Ø4x8		2	2	2	2	2	2	2	2		
24	R205425	Embellecedor chimenea		2	2	2	2	3	3	3	3		

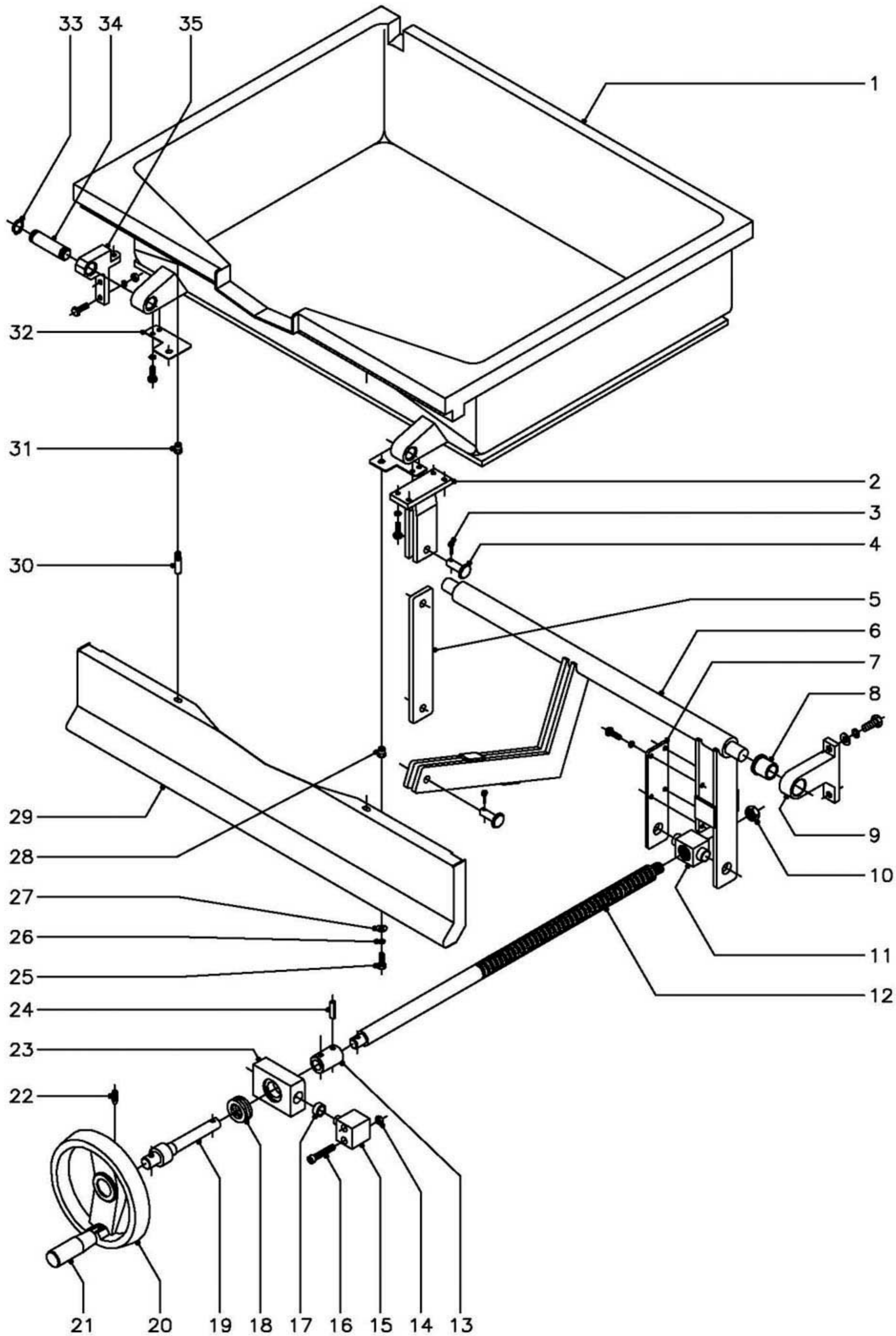

MOD.

SARTENES BASCULANTES GAMA 900

ZONA

CUBA (Elevacion Manual)

PLANO

C-1198

ITEM	CODIGO	DENOMINACION	TEXTO	SBG9-10	SBG9-10 I	SBE9-10	SBE9-10 I							NOTAS
1	X156155	Cuba SBG9-10		1	-	-	-							
1	X156150	Cuba SBG9-10 I		-	1	-	-							
1	X146125	Cuba SBE9-10		-	-	1	-							
1	X146126	Cuba SBE9-10 I		-	-	-	1							
2	X156157	Horquilla de giro		1	-	1	-							
	Q262040	Arandela muelle A-6		4	-	4	-							
	Q012042	Tornillo exagonal M-6x15		4	-	4	-							
2	-	Horquilla de giro (soldado a cuba)		-	1	-	1							
3	Q352024	Pasador de aletas Ø4x25		2	2	2	2							
4	X156123	Bulon Ø12		2	2	2	2							
5	X156151	Brazo		1	1	1	1							
6	X156148	Brazo elevador		1	1	1	1							
7	X156149	Brazo lateral		1	1	1	1							
	Q012042	Tornillo exagonal M-6x15		4	4	4	4							
	Q262040	Arandela muelle A-6		4	4	4	4							
8	X109550	Cojinete		2	2	2	2							
9	X150108	Soporte giro		2	2	2	2							
	Q232060	Arandela plana A-10		4	4	4	4							
	Q261060	Arandela muelle A-10		4	4	4	4							
	Q012063	Tornillo exagonal M-10x20		4	4	4	4							
10	Q222015	Tuerca exagonal 3/8"		1	1	1	1							
11	X156154	Tuerca de husillo		1	1	1	1							
12	X156152	Husillo		1	1	1	1							
13	X156115	Casquillo		1	1	1	1							
14	Q162040	Tuerca exagonal M-6		4	4	4	4							
15	X156113	Pivote de giro		2	2	2	2							
16	Q052046	Tornillo allem M-6x40		4	4	4	4							
17	S116126	Cojinete cilindrico		2	2	2	2							
18	X156125	Rodamiento		1	1	1	1							

MOD.		SARTENES BASCULANTES GAMA 900		ZONA	CUBA (Elevacion Manual)				PLANO	C-1198	
ITEM	CODIGO	DENOMINACION	TEXTO	SBG9-10	SBG9-10 I	SBE9-10	SBE9-10 I				NOTAS
19	X156153	Eje volante		1	1	1	1				
20	X156139	Volante con mango inoxidable		1	1	1	1				
21	X156135	Mango abatible inoxidable		1	1	1	1				
22	Q131552	Varilla roscada M-8x15		2	2	2	2				
23	X156114	Soporte rodamiento		1	1	1	1				
24	Q371027	Manguito Ø8x30		2	2	2	2				
25	Q012042	Tornillo exagonal M-6x15		2	2	2	2				
26	Q262040	Arandela muelle A-6		2	2	2	2				
27	Q302022	Arandela plana Ø16xØ6x1,2		2	2	2	2				
28	Q221343	Remache exagonal M-6		2	2	2	2				
29	X152830	Panel portamandos (Cuba fundid.)		1	-	1	-				
29	X152833	Panel portamandos (Cuba inox.)		-	1	-	1				
30	Q151336	Tornillo soporte guia portamandos		2	2	2	2				
31	Q221343	Remache exagonal M-6		2	2	2	2				
32	X156156	Amarre panel portamandos		2	2	2	2				
	Q262040	Arandela muelle A-6		4	-	4	-				
	Q012042	Tornillo exagonal M-6x15		4	-	4	-				
33	Q301020	Anillo seguridad Ø20x1,2		4	4	4	4				
34	X109511	Bulon		2	2	2	2				
35	X156145	Soporte giro cuba		2	2	2	2				
	Q012043	Tornillo exagonal M-6x20		6	6	6	6				
	Q262040	Arandela muelle A-6		6	6	6	6				
	Q162040	Tuerca exagonal M-6		6	6	6	6				

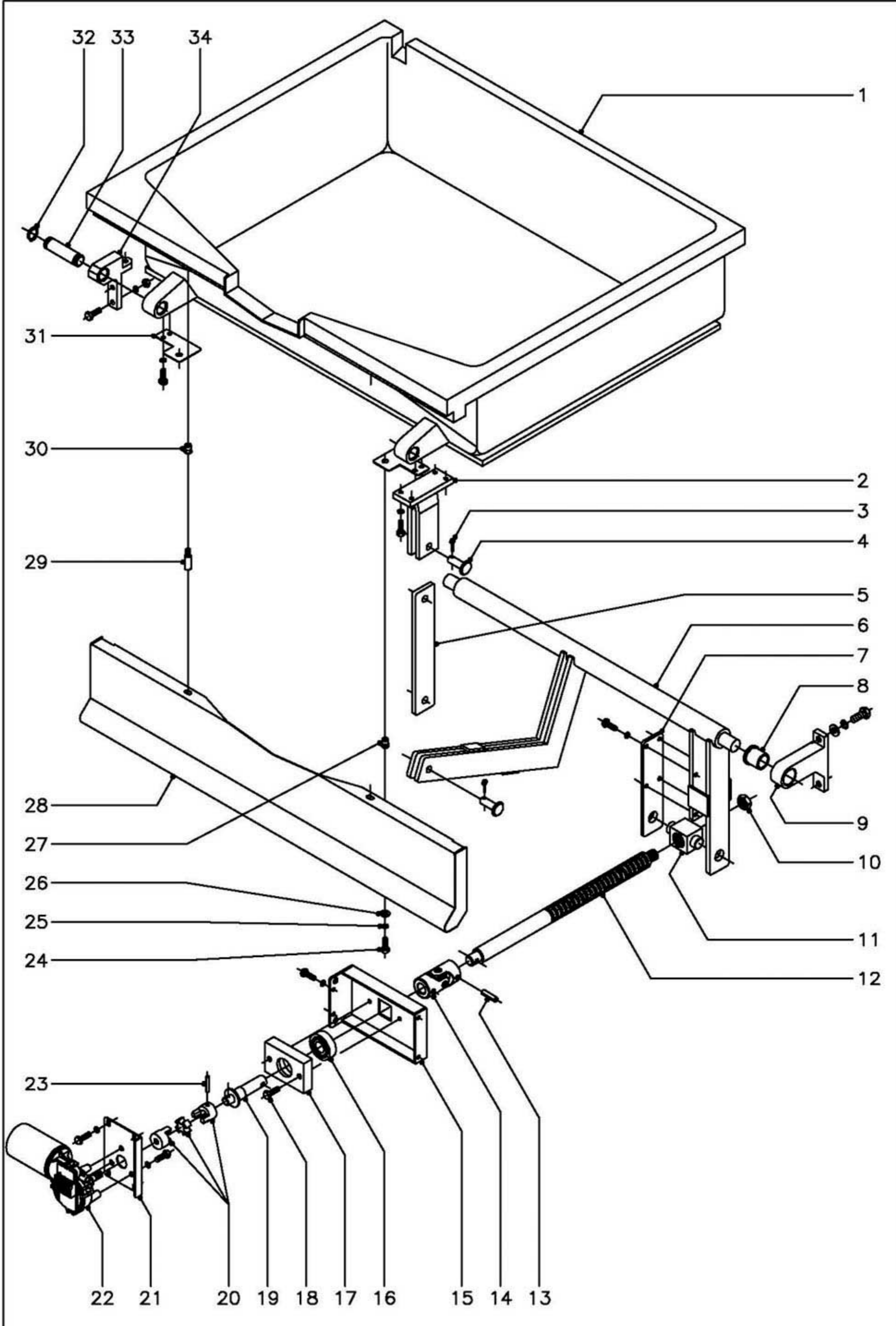

N plano	Firma	Fecha	Aparato	CUBA	Lamina	Fagor Industrial S.Coop. FAGOR
C-1199		6-2002	SARTEN BASCULANTE 900 (Elev.Motor)		3	Oñate

MOD.

SARTENES BASCULANTES GAMA 900

ZONA

CUBA (Elevacion Motor)

PLANO

C-1199

ITEM	CODIGO	DENOMINACION	TEXTO	SBG9-10 M	SBG9-10 I M	SBE9-10 M	SBE9-10 I M	SBG9-15 I M	SBE9-15 I M					NOTAS
1	X156155	Cuba SBG9-10		1	-	-	-							
1	X156150	Cuba SBG9-10 I		-	1	-	-							
1	X146125	Cuba SBE9-10		-	-	1	-							
1	X146126	Cuba SBE9-10 I		-	-	-	1							
1	X286105	Cuba SBG9-15 I		-	-	-	-	1	-					
1	X426102	Cuba SBE9-15 I		-	-	-	-	-	1					
2	X156157	Horquilla de giro		1	-	1	-	-	-					
	Q262040	Arandela muelle A-6		4	-	4	-	-	-					
	Q012042	Tornillo exagonal M-6x15		4	-	4	-	-	-					
2	-	Horquilla de giro (soldada a cuba)		-	1	-	1	1	1					
3	Q352024	Pasador de aletas Ø4x25		2	2	2	2	2	2					
4	X156123	Bulon Ø12		2	2	2	2	2	2					
5	X156151	Brazo		1	1	1	1	1	1					
6	X156148	Brazo elevador		1	1	1	1	-	-					
6	X286106	Brazo elevador		-	-	-	-	1	-					
6	X426103	Brazo elevador		-	-	-	-	-	1					
7	X156149	Brazo lateral		1	1	1	1	1	1					
	Q012042	Tornillo exagonal M-6x15		4	4	4	4	4	4					
	Q262040	Arandela muelle A-6		4	4	4	4	4	4					
8	X109550	Cojinete		2	2	2	2	2	2					
9	X150108	Soporte giro		2	2	2	2	2	2					
	Q232060	Arandela plana A-10		4	4	4	4	4	4					
	Q261060	Arandela muelle A-10		4	4	4	4	4	4					
	Q012063	Tornillo exagonal M-10x20		4	4	4	4	4	4					
10	Q222015	Tuerca exagonal 3/8"		1	1	1	1	1	1					
11	X156154	Tuerca de husillo		1	1	1	1	1	1					
12	X156152	Husillo		1	1	1	1	1	1					
13	Q371027	Manguito Ø8x30		2	2	2	2	2	2					
14	X126114	Junta universal		1	1	1	1	1	1					

MOD.

SARTENES BASCULANTES GAMA 900

ZONA

CUBA (Elevacion Motor)

PLANO

C-1199

ITEM	CODIGO	DENOMINACION	TEXTO	SBG9-10 M	SBG9-10 I M	SBE9-10 M	SBE9-10 I M	SBG9-15 I M	SBE9-15 I M				NOTAS
15	X342607	Soporte eje motor		1	1	1	1	1	1				
	Q012032	Tornillo exagonal M-5x15		4	4	4	4	4	4				
	Q262030	Arandela muelle A-5		4	4	4	4	4	4				
16	X346109	Rodamiento SKF		1	1	1	1	1	1				
17	X346105	Soporte rodamiento		1	1	1	1	1	1				
18	Q012044	Tornillo exagonal M-6x25		2	2	2	2	2	2				
19	X346106	Eje motor		1	1	1	1	1	1				
20	X346107	Acoplamiento elastico		1	1	1	1	1	1				
21	X342603	Soporte motor		1	1	1	1	1	1				
	Q012042	Tornillo exagonal M-6x15		4	4	4	4	4	4				
	Q262040	Arandela muelle A-6		4	4	4	4	4	4				
22	X343020	Motorreductor elevacion cuba		1	1	1	1	1	1				
	Q012042	Tornillo exagonal M-6x15		3	3	3	3	3	3				
	Q262040	Arandela muelle A-6		3	3	3	3	3	3				
23	Q371032	Manguito Ø5x30		1	1	1	1	1	1				
24	Q012042	Tornillo exagonal M-6x15		2	2	2	2	2	2				
25	Q262040	Arandela muelle A-6		2	2	2	2	2	2				
26	Q302022	Arandela plana Ø16xØ6x1,2		2	2	2	2	2	2				
27	Q221343	Remache exagonal M-6		2	2	2	2	2	2				
28	X152830	Panel portamandos (Cuba fundid.)		1	-	1	-	-	-				
28	X152833	Panel portamandos (Cuba inox.)		-	1	-	1	-	-				
28	X282815	Panel portamandos SB-15		-	-	-	-	1	1				
29	Q151336	Tornillo soporte guia portamandos		2	2	2	2	2	2				
30	Q221343	Remache exagonal M-6		-	2	-	2	2	2				
31	X156156	Amarre panel portamandos		2	-	2	-	-	-				
	Q262040	Arandela muelle A-6		4	-	4	-	-	-				
	Q012042	Tornillo exagonal M-6x15		4	-	4	-	-	-				
32	Q301020	Anillo seguridad Ø20x1,2		4	4	4	4	4	4				
33	X109511	Bulon		2	2	2	2	2	2				

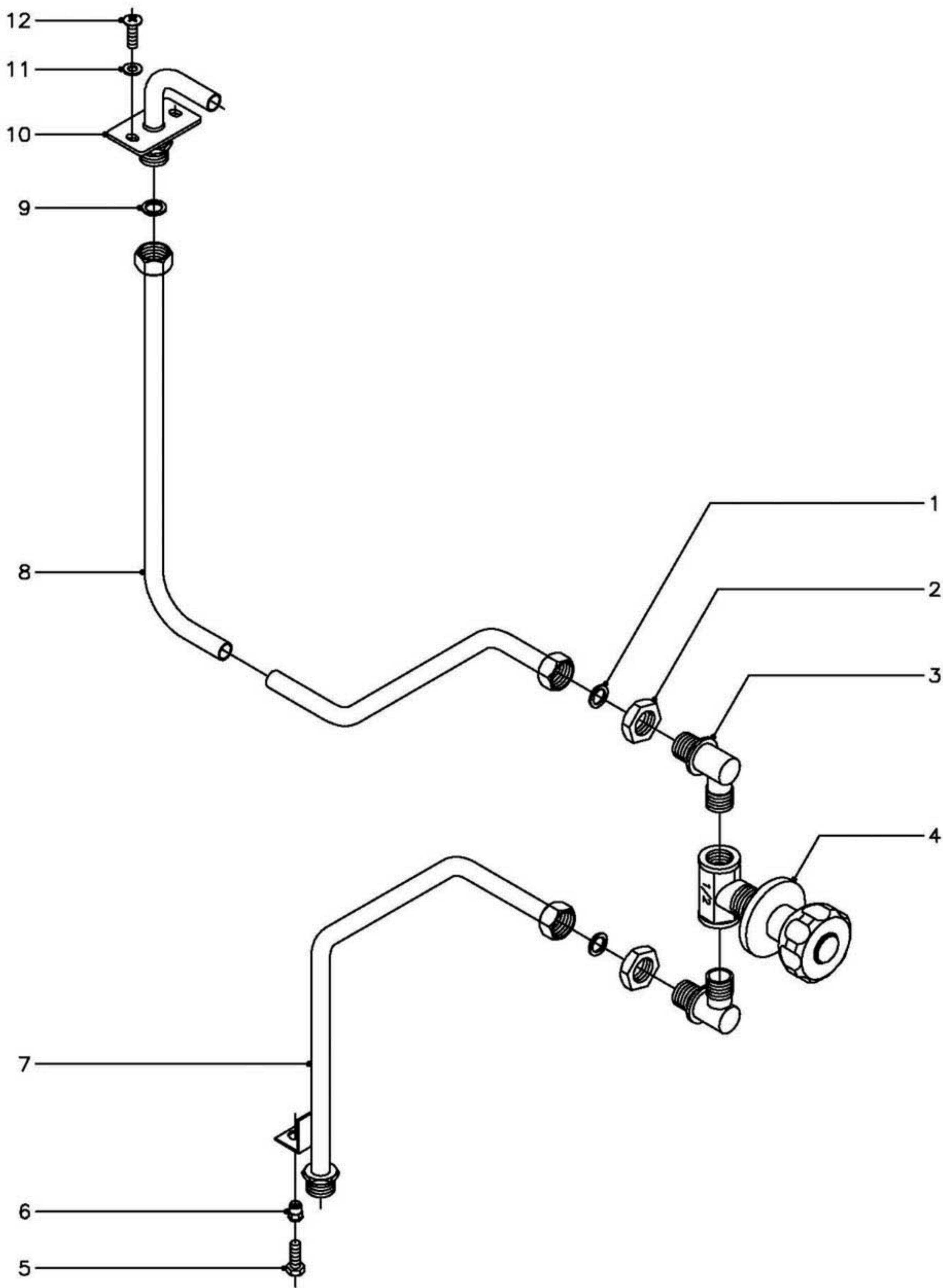

N plano
C-1200

Firma

Fecha
6-2002

Aparato
SARTEN BASCULANTE 900

TOMA DE AGUA

Lamina
4

Fogor Industrial S.Coop. **FOGOR**
Orate

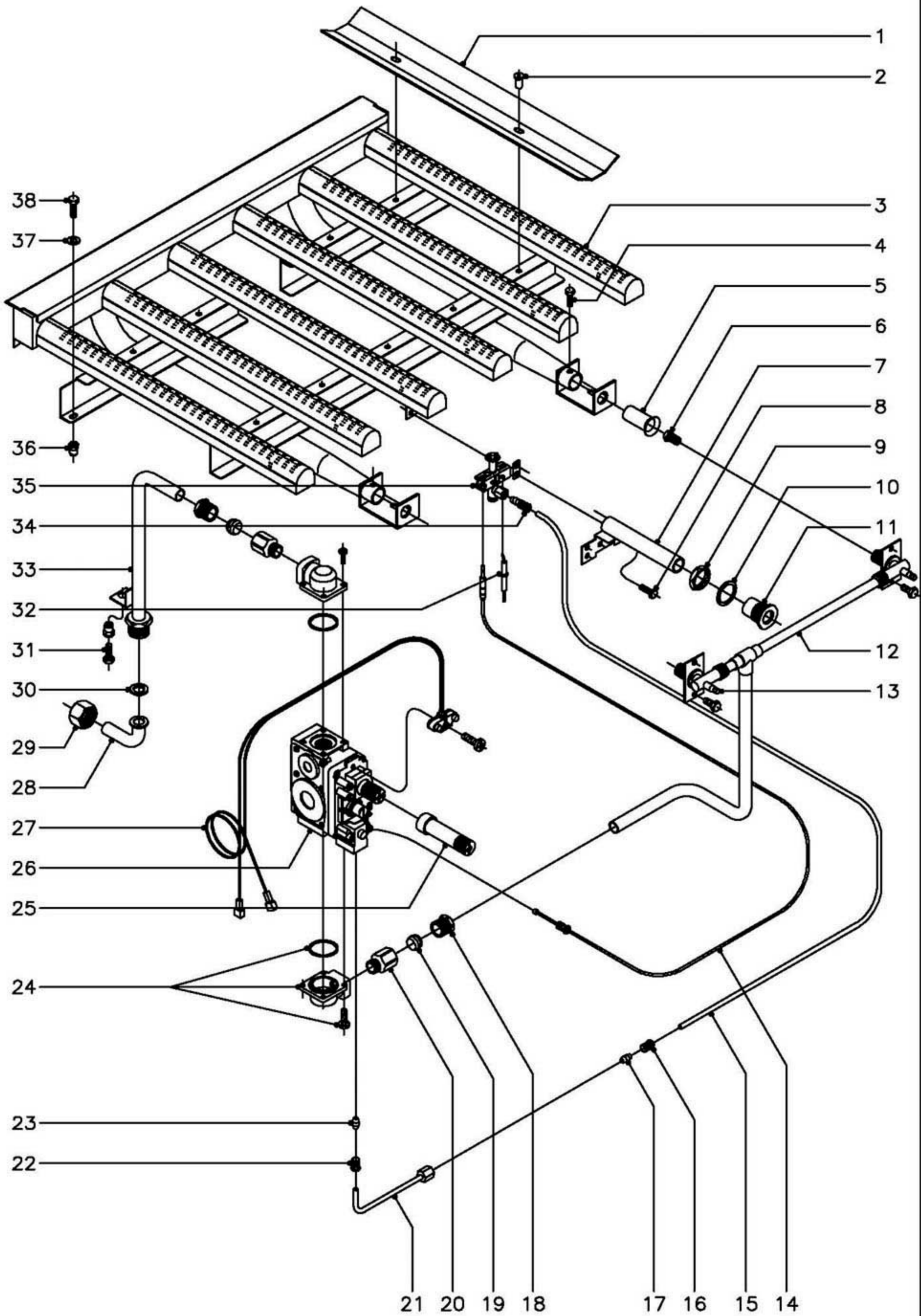

MOD.

SARTENES BASCULANTES GAMA 900

ZONA

PARTE FUNCIONAL GAS

PLANO

C-1201

ITEM	CODIGO	DENOMINACION	TEXTO	SBG9-10	SBG9-15									NOTAS
1	X155720	Deflector largo		3	6									
1	X155721	Deflector corto		1	1									
2	Q419005	Remache tubular Ø4x8		8	14									
3	X155710	Quemador		1	-									
3	X285710	Quemador		-	1									
4	Q012031	Tornillo exagonal M-5x10		2	2									
5	U325707	Regulador de aire		2	2									
6	U052401	Tobera Ø1,45 (Butano Propano)		2	3									
6	U262400	Tobera Ø2,15 (Gas Natural)		2	3									
6	X102403	Tobera Ø4,58 (Gas Villa)		2	3									
7	X155035	Tubo de encendido		1	1									
8	Q012031	Tornillo exagonal M-5x10		2	2									
9	Q221324	Tuerca exagonal 3/4"		1	1									
10	Q306027	Arandela plana Ø33,8x27x1,5		1	1									
11	S112804	Embelledor tubo de encendido		1	1									
12	X155030	Conduccion a quemador		1	-									
12	X285015	Conduccion a quemador		-	1									
	Q012031	Tornillo exagonal M-5x10		4	4									
13	Q153002	Tornillo tapon		2	3									
14	U562130	Termopar L=850		1	1									
15	X155032	Tubo piloto		1	-									
15	X285017	Tubo piloto		-	1									
16	U195009	Manguito empalme		1	1									
17	X205028	Bicono Ø6		1	1									
18	X012104	Manguito para racord 1/2"		2	2									
19	X012105	Bicono Ø16		2	2									
20	X162101	Racord 1/2"		2	2									
21	X155043	Tubo piloto a valvula		1	1									
22	U195009	Manguito empalme		1	1									

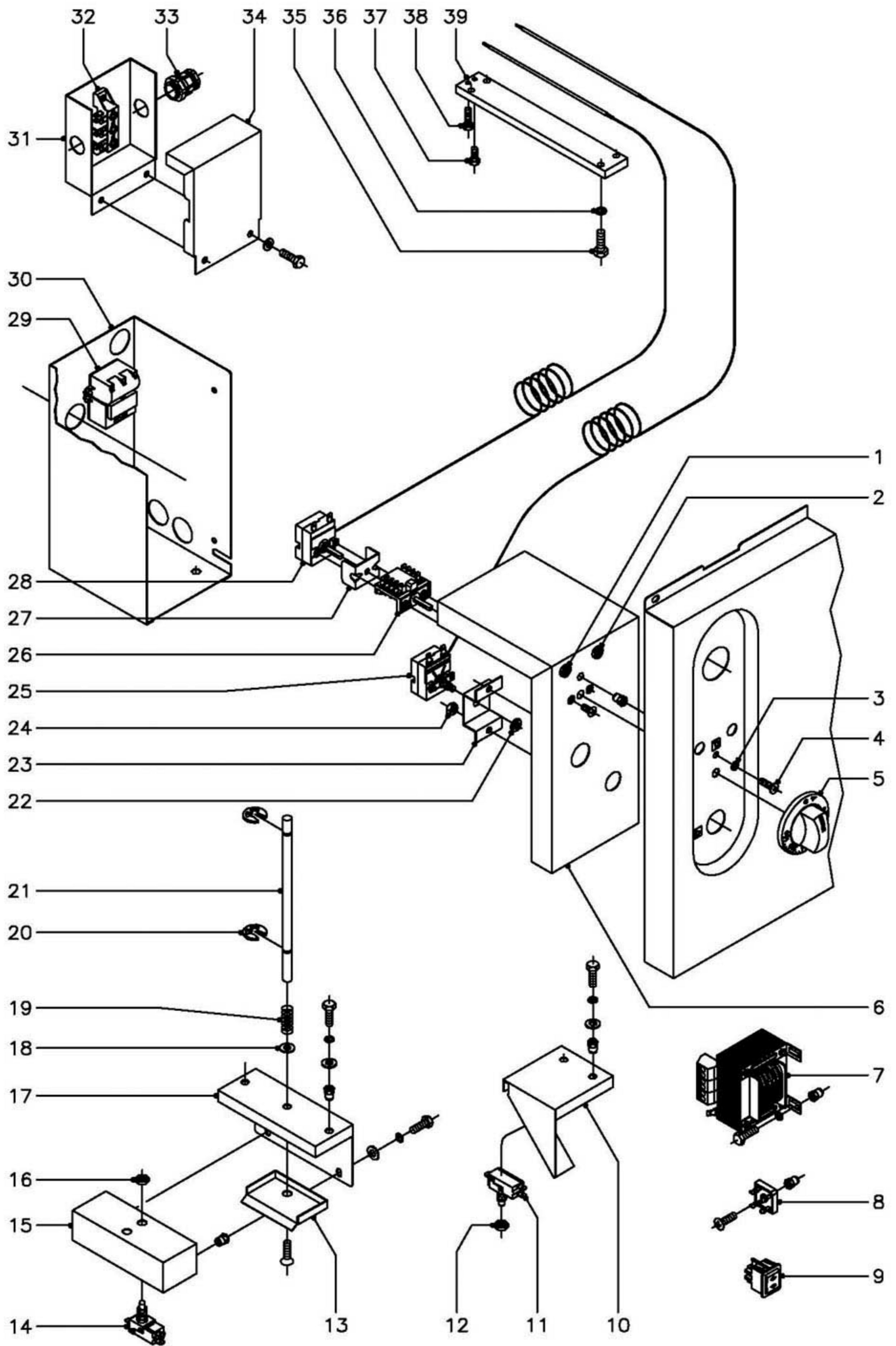

N plano
C-1202

Firma

Fecha
6-2002

Aparato
SARTEN BASCULANTE 900 A GAS

PARTE FUNCIONAL ELECTRICA

Lamina
6

Fagor Industrial S.Coop. **FAGOR**
Oferta

MOD.

SARTENES BASCULANTES GAMA 900

ZONA

PARTE FUNCIONAL ELECTRICA (GAS)

PLANO

C-1202

ITEM	CODIGO	DENOMINACION	TEXTO	SBG9-10	SBG9-10 I	SBG9-10 M	SBG9-10 I M	SBG9-15 I M						NOTAS
1	X143017	Piloto verde		1	1	1	1							
2	X143018	Piloto ambar		1	1	1	1							
3	Q262030	Arandela muelle A-5		1	1	1	1							
4	Q152004	Tornillo aplastado M-5x13		1	1	1	1							
	Q221342	Remache exagonal M-5		1	1	1	1							
5	X152111	Boton de mando Ø6		1	1	1	1							
	Q281000	Anillo de compresion mando		1	1	1	1							
6	X152667	Tapa caja		1	1	1	1							
7	X343021	Transformador		-	-	1	1							
	Q012031	Tornillo exagonal M-5x10		-	-	4	4							
	Q302022	Arandela plana Ø16xØ6x1,2		-	-	4	4							
	Q221342	Remache exagonal M-5		-	-	4	4							
	X342605	Tapa transformador		-	-	1	1							
	X342606	Caja transformador		-	-	1	1							
	Q012031	Tornillo exagonal M-5x10		-	-	4	4							
	Q302022	Arandela plana Ø16xØ6x1,2		-	-	4	4							
	X342609	Escuadra amarre tapa transforma.		-	-	1	1							
	Q419005	Remache tubular Ø4x8		-	-	4	4							
8	X343022	Puente rectificador		-	-	1	1							
	Q152004	Tornillo aplastado M-5x13		-	-	1	1							
	Q221342	Remache exagonal M-5		-	-	1	1							
9	X343009	Pulsador doble con protector		-	-	1	1							
	X342608	Soporte pulsador		-	-	1	1							
	Q012042	Tornillo exagonal M-6x15		-	-	4	4							
	Q162040	Tuerca exagonal M-6		-	-	4	4							
	Q302022	Arandela plana Ø16xØ6x1,2		-	-	4	4							
10	X342602	Soporte micro		-	-	1	1							
	Q012031	Tornillo exagonal M-5x10		-	-	2	2							
	Q262030	Arandela muelle A-5		-	-	2	2							

MOD.

SARTENES BASCULANTES GAMA 900

ZONA

PARTE FUNCIONAL ELECTRICA (GAS)

PLANO

C-1202

ITEM	CODIGO	DENOMINACION	TEXTO	SBG9-10	SBG9-10 I	SBG9-10 M	SBG9-10 I M	SBG9-15 I M						NOTAS
	Q302022	Arandela plana Ø16xØ6x1,2		-	-	2	2							
	Q221342	Remache exagonal M-5		-	-	2	2							
11	X343015	Microrruptor		-	-	1	1							
12	Q222005	Tuerca exagonal M-10x0,75		-	-	1	1							
13	X152646	Proteccion superior		1	1	1	1							
	Q152024	Tornillo avellanado M-4x8		1	1	1	1							
14	X343015	Microrruptor		1	1	2	2							
15	X152681	Caja portamicro		1	1	1	1							
	Q221342	Remache exagonal M-5		2	2	2	2							
	Q302022	Arandela plana Ø16xØ6x1,2		2	2	2	2							
	Q262030	Arandela muelle A-5		2	2	2	2							
	Q012031	Tornillo exagonal M-5x10		2	2	2	2							
16	Q222005	Tuerca exagonal M-10x0,75		1	1	2	2							
17	X152680	Soporte caja portamicro		1	1	1	1							
	Q221342	Remache exagonal M-5		2	2	2	2							
	Q302022	Arandela plana Ø16xØ6x1,2		2	2	2	2							
	Q262030	Arandela muelle A-5		2	2	2	2							
	Q012031	Tornillo exagonal M-5x10		2	2	2	2							
18	Q232050	Arandela plana A-8		1	1	1	1							
19	Z700603	Muelle		1	1	1	1							
20	Q271033	Arandela de seguridad Ø6		2	2	2	2							
21	X152682	Eje pulsador micro		1	1	1	1							
22	Q223022	Tuerca exagonal M-8x1		1	1	1	1							
23	X152661	Soporte limitador		1	1	1	1							
24	Q162030	Tuerca exagonal M-5		2	2	2	2							
25	R612103	Termostato limitador		1	1	1	1							
26	X163007	Conmutador acople termostato		1	1	1	1							
	Q151320	Tornillo alomado M-4x6		2	2	2	2							
27	X313001	'U" soporte termostato		1	1	1	1							

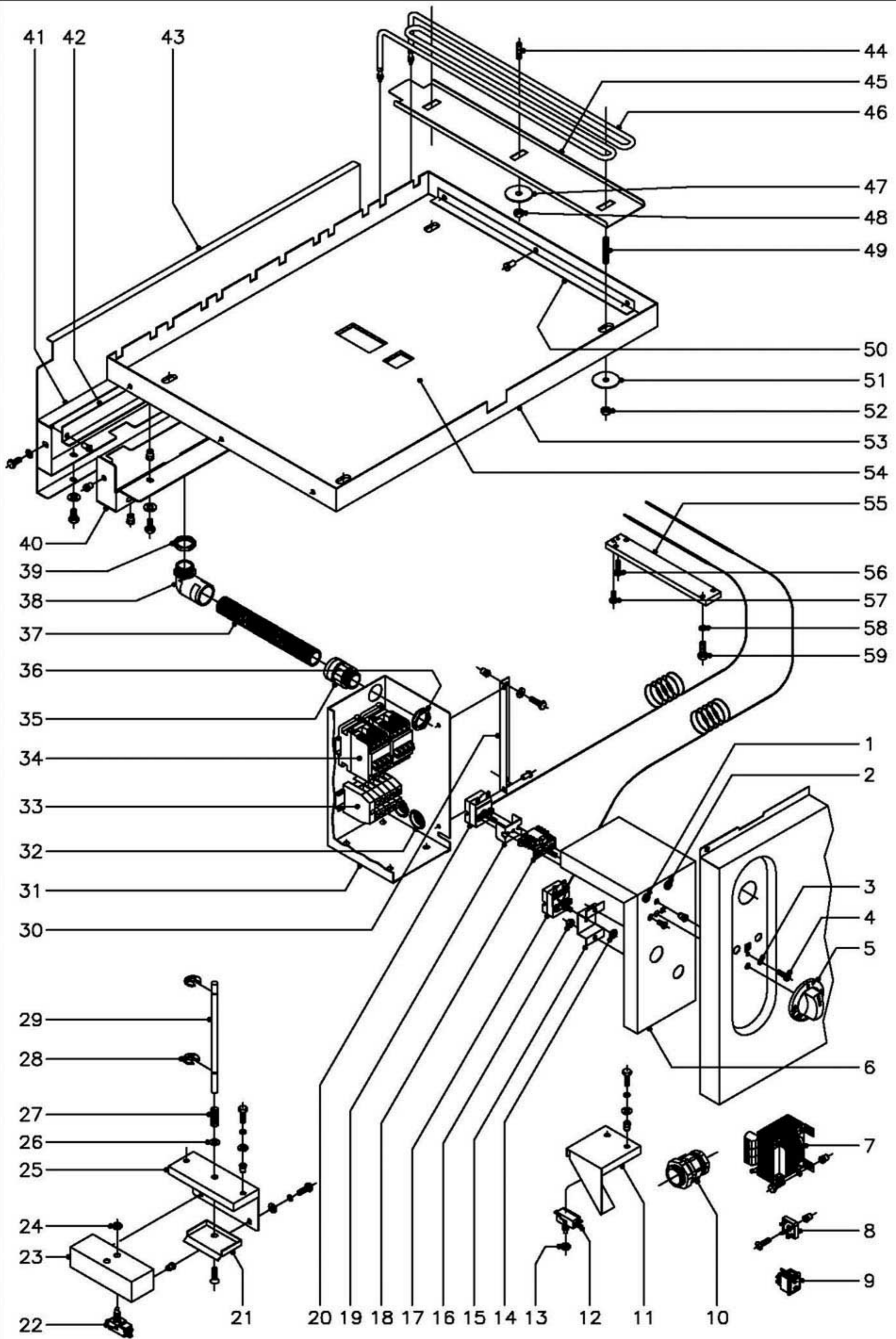

N plano	Firma	Fecha	Aparato	PARTE FUNCIONAL ELECTRICA	Lamina	Fagor Industrial S.Coop. FAGOR
C-1203		6-2002	SARTEN BASCULANTE 900 ELECTRICA		7	Orate

MOD.

SARTENES BASCULANTES GAMA 900

ZONA

PARTE FUNCIONAL ELECTRICA (ELECTRICAS)

PLANO

C-1203

ITEM	CODIGO	DENOMINACION	TEXTO	SBE9-10	SBE9-10 I	SBE9-10 M	SBE9-10 I M	SBE9-15 I M					NOTAS
1	X143017	Piloto verde		1	1	1	1	1					
2	X143018	Piloto ambar		1	1	1	1	1					
3	Q262030	Arandela muelle A-5		1	1	1	1	1					
4	Q152004	Tornillo aplastado M-5x13		1	1	1	1	1					
	Q221342	Remache exagonal M-5		1	1	1	1	1					
5	U673017	Boton de mando Ø6		1	1	1	1	1					
	Q281000	Anillo de compresion mando		1	1	1	1	1					
6	X152667	Tapa caja		1	1	1	1	1					
7	X343021	Transformador		-	-	1	1	1					
	Q012031	Tornillo exagonal M-5x10		-	-	4	4	4					
	Q302022	Arandela plana Ø16xØ6x1,2		-	-	4	4	4					
	Q221342	Remache exagonal M-5		-	-	4	4	4					
	X342605	Tapa transformador		-	-	1	1	1					
	X342606	Caja transformador		-	-	1	1	1					
	Q012031	Tornillo exagonal M-5x10		-	-	4	4	4					
	Q302022	Arandela plana Ø16xØ6x1,2		-	-	4	4	4					
	X342609	Escuadra amarre tapa transforma.		-	-	1	1	1					
	Q419005	Remache tubular Ø4x8		-	-	4	4	4					
8	X343022	Puente rectificador		-	-	1	1	1					
	Q152004	Tornillo aplastado M-5x13		-	-	1	1	1					
	Q221342	Remache exagonal M-5		-	-	1	1	1					
9	X343009	Pulsador doble con protector		-	-	1	1	1					
	X342608	Soporte pulsador		-	-	1	1	1					
	Q012042	Tornillo exagonal M-6x15		-	-	4	4	4					
	Q162040	Tuerca exagonal M-6		-	-	4	4	4					
	Q302022	Arandela plana Ø16xØ6x1,2		-	-	4	4	4					
10	R033002	Prensaestopas		1	1	1	1	1					
11	X342602	Soporte micro		-	-	1	1	1					
	Q012031	Tornillo exagonal M-5x10		-	-	2	2	2					

MOD.

SARTENES BASCULANTES GAMA 900

ZONA

PARTE FUNCIONAL ELECTRICA (ELECTRICAS)

PLANO

C-1203

ITEM	CODIGO	DENOMINACION	TEXTO	SBE9-10	SBE9-10 I	SBE9-10 M	SBE9-10 I M	SBE9-15 I M					NOTAS
	Q262030	Arandela muelle A-5		-	-	2	2	2					
	Q302022	Arandela plana Ø16xØ6x1,2		-	-	2	2	2					
	Q221342	Remache exagonal M-5		-	-	2	2	2					
12	X343015	Microrruptor		-	-	1	1	1					
13	Q222005	Tuerca exagonal M-10x0,75		-	-	1	1	1					
14	Q223022	Tuerca exagonal M-8x1		1	1	1	1	1					
15	X152661	Soporte limitador		1	1	1	1	1					
16	Q162030	Tuerca exagonal M-5		2	2	2	2	2					
17	R612103	Termostato limitador		1	1	1	1	1					
18	X163007	Conmutador acople termostato		1	1	1	1	1					
	Q151320	Tornillo alomado M-4x6		2	2	2	2	2					
19	X313001	'U" soporte termostato		1	1	1	1	1					
20	X153000	Termostato		1	1	1	1	1					
21	X152646	Proteccion superior		1	1	1	1	1					
	Q152024	Tornillo avellanado M-4x8		1	1	1	1	1					
22	X343015	Microrruptor		1	1	2	2	2					
23	X152681	Caja portamicro		1	1	1	1	1					
	Q221342	Remache exagonal M-5		2	2	2	2	2					
	Q302022	Arandela plana Ø16xØ6x1,2		2	2	2	2	2					
	Q262030	Arandela muelle A-5		2	2	2	2	2					
	Q012031	Tornillo exagonal M-5x10		2	2	2	2	2					
24	Q222005	Tuerca exagonal M-10x0,75		1	1	2	2	2					
25	X152680	Soporte caja portamicro		1	1	1	1	1					
	Q221342	Remache exagonal M-5		2	2	2	2	2					
	Q302022	Arandela plana Ø16xØ6x1,2		2	2	2	2	2					
	Q262030	Arandela muelle A-5		2	2	2	2	2					
	Q012031	Tornillo exagonal M-5x10		2	2	2	2	2					
26	Q232050	Arandela plana A-8		1	1	1	1	1					
27	Z700603	Muelle		1	1	1	1	1					

MOD.

SARTENES BASCULANTES GAMA 900

ZONA

PARTE FUNCIONAL ELECTRICA (ELECTRICAS)

PLANO

C-1203

ITEM	CODIGO	DENOMINACION	TEXTO	SBE9-10	SBE9-10 I	SBE9-10 M	SBE9-10 I M	SBE9-15 I M					NOTAS
28	Q271033	Arandela de seguridad Ø6		2	2	2	2	2					
29	X152682	Eje pulsador micro		1	1	1	1	1					
30	X152657	Soporte caja		1	1	1	1	1					
	Q221342	Remache exagonal M-5		2	2	2	2	2					
	Q302022	Arandela plana Ø16xØ6x1,2		2	2	2	2	2					
	Q012031	Tornillo exagonal M-5x10		2	2	2	2	2					
31	X152656	Soporte valvula (caja electrica)		1	1	1	1	1					
	Q419005	Remache tubular Ø4x8		2	2	2	2	2					
32	X723014	Pasamuros Ø30		2	2	2	2	2					
33	P453025	Borna fases 10 (gris)		3	3	3	3	-					
	Z263302	Borna neutro 10 (azul)		1	1	1	1	-					
	P453026	Borna tierra 10 (amarillo-verde)		1	1	1	1	-					
	Z263303	Tope final		1	1	1	1	-					
33	Z683069	Borna fases 16 (gris)		-	-	-	-	3					
	Z683097	Borna neutro 16 (azul)		-	-	-	-	1					
	Z683070	Borna tierra 16 (amarillo-verde)		-	-	-	-	1					
	Z683096	Tope final		-	-	-	-	1					
	Z403016	Guia contactor L=100		1	1	1	1	1					
	Q419005	Remache tubular Ø4x8		2	2	2	2	2					
34	R663031	Contacto 3TF3010-OAL2		2	2	2	2	-					
34	X183011	Contacto 3RT1024-1AN20		-	-	-	-	2					
	Z403016	Guia contactor L=100		1	1	1	1	1					
	Q419005	Remache tubular Ø4x8		2	2	2	2	2					
35	X713021	Racord		1	1	1	1	1					
36	X713022	Tuerca PG-21		1	1	1	1	1					
37	3712300	Tubo PG-21 L=850 mm.		1	1	1	1	1					
38	Z703006	Racord a 90°		1	1	1	1	1					
39	X143012	Contratuerca laton		1	1	1	1	1					
40	X142651	Cubierta de bornas 10		1	1	1	1	-					

MOD.

SARTENES BASCULANTES GAMA 900

ZONA

PARTE FUNCIONAL ELECTRICA (ELECTRICAS)

PLANO

C-1203

ITEM	CODIGO	DENOMINACION	TEXTO	SBE9-10	SBE9-10 I	SBE9-10 M	SBE9-10 I M	SBE9-15 I M					NOTAS
40	X422616	Cubierta de bornas 15		-	-	-	-	1					
	Q221342	Remache exagonal M-5		3	3	3	3	4					
	Q302022	Arandela plana Ø16xØ6x1,2		3	3	3	3	4					
	Q012032	Tornillo exagonal M-5x15		3	3	3	3	4					
41	X142652	Tapa cubierta bornas 10		1	1	1	1	-					
41	X422617	Tapa cubierta bornas 15		-	-	-	-	1					
	Q221342	Remache exagonal M-5		2	2	2	2	2					
	Q302022	Arandela plana Ø16xØ6x1,2		2	2	2	2	2					
	Q012032	Tornillo exagonal M-5x15		2	2	2	2	2					
42	X402601	Escuadra separador resistencias		2	2	2	2	3					
	Q419005	Remache tubular Ø4x8		4	4	4	4	6					
43	X142653	Proteccion agua cuba 10		1	1	1	1	-					
43	X422618	Proteccion agua cuba 15		-	-	-	-	1					
	Q221342	Remache exagonal M-5		3	3	3	3	4					
	Q302022	Arandela plana Ø16xØ6x1,2		3	3	3	3	4					
	Q012032	Tornillo exagonal M-5x15		3	3	3	3	4					
44	Q131555	Varilla roscada M-8x30		14	14	14	14	21					
45	X142620	Amarre resistencias		6	6	6	6	9					
46	X143010	Resistencia (2000 W., 230 V.)		6	6	6	6	9					
47	Q302024	Arandela plana Ø44xØ9x1,5		14	14	14	14	21					
48	Q162050	Tuerca exagonal M-8		14	14	14	14	21					
49	Q131558	Varilla roscada M-8x60		4	4	4	4	6					
50	X142609	Amarre aislante		3	3	3	3	3					
	Q419005	Remache tubular Ø4x8		9	9	9	9	9					
51	Q302024	Arandela plana Ø44xØ9x1,5		4	4	4	4	6					
52	Q162050	Tuerca exagonal M-8		4	4	4	4	6					
53	X142650	Cubierta resistencias 10		1	1	1	1	-					
53	X422615	Cubierta resistencias 15		-	-	-	-	1					
54	X142656	Aislante cubierta barlan 730x520x5		1	1	1	1	-					

MOD.

SARTENES BASCULANTES GAMA 900

ZONA

PIEZAS ESPECIFICAS PARA LOS DISTINTOS GASES

PLANO

C-1201

ITEM	CODIGO	DENOMINACION	TEXTO	SBG9-10	SBG9-15													NOTAS
			<u>BUTANO-PROPANO</u>															
6	U052401	Tobera quemador Ø1,45		2	3													
35	U442138	Inyector piloto Ø0,25		1	1													
			<u>GAS NATURAL</u>															
6	U262400	Tobera quemador Ø2,15		2	3													
35	U442137	Inyector piloto Ø0,40		1	1													
			<u>GAS VILLA</u>															
6	X102403	Tobera quemador Ø4,58		2	3													
35	U442138	Inyector piloto Ø0,25		1	1													REGULAR

MOD.

SARTENES BASCULANTES GAMA 900

ZONA

VARIOS (SARTENES ELECTRICAS)

PLANO

ITEM

CODIGO

DENOMINACION

TEXTO

SBE9-10

SBE9-10 M

SBE9-15 I M

NOTAS

X146511

Folleto de instrucciones

1

1

1

X143006

Esquema electrico adhesivo

1

-

-

Plano HC-75709

X403002

Esquema electrico adhesivo

-

1

1

Plano HC-75708

X143005

Esquema electrico de montaje

1

1

1

Plano HC-75713

X143015

Instalacion electrica

1

1

1

X143004

Cableado resistencias 10

1

1

-

X423004

Cableado resistencias 15

-

-

1

X143016

Cableado regleta a contactores 10

2

2

-

X423005

Cableado regleta a contactores 15

-

-

2

X283000

Cableado motorreductor elevacion

-

1

1

SBG9-10,SBG-710

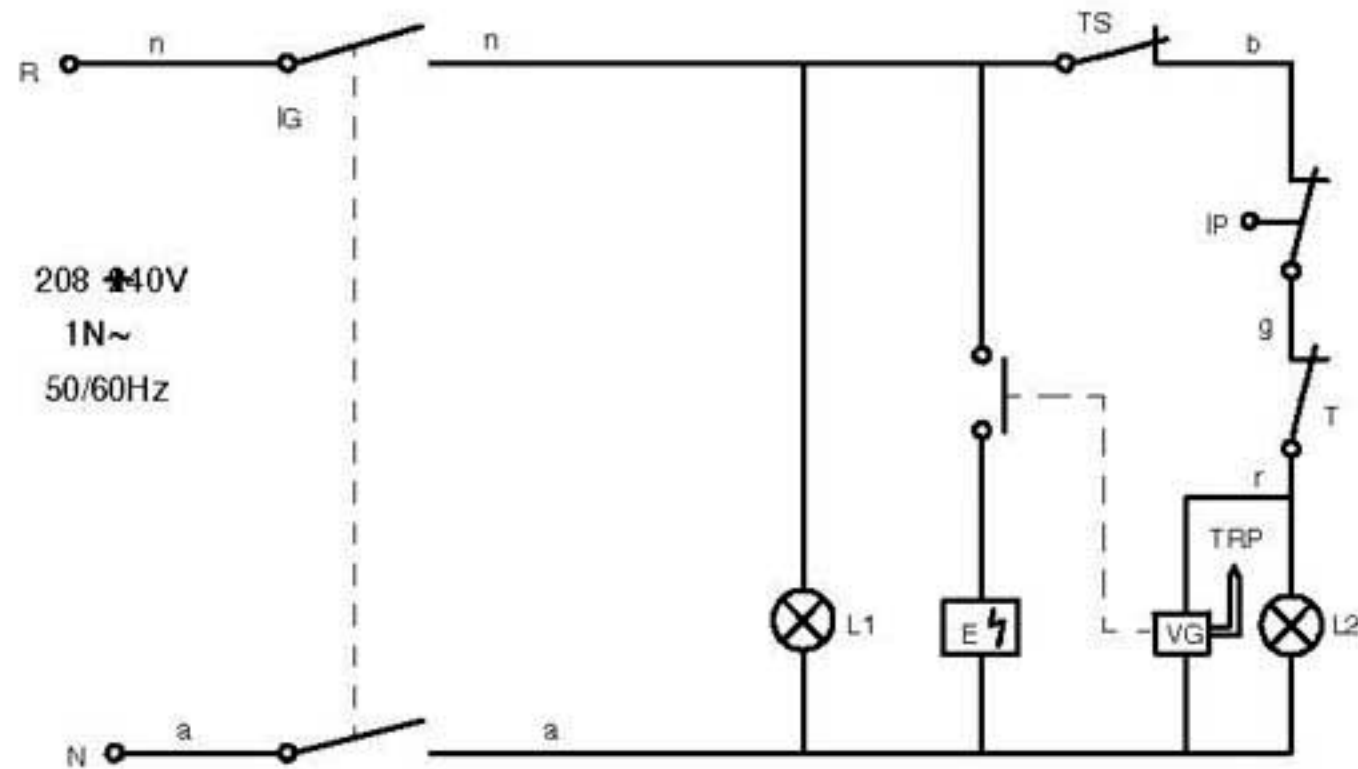

n: negro	n: noir	n: black	n: schwarz	n: nero
r: rojo	r: rouge	r: red	r: rot	r: rosso
b: blanco	b: blanc	b: white	b: weiss	b: bianco
g: gris	g: gris	g: grey	g: grau	g: grigio
a: azul	a: bleu	a: blue	a: blau	a: azzurro

E: Encendedor
 IG: Interruptor general
 IP: Micro seguridad
 L1: Lampara marcha
 L2: Lampara calentamiento
 T: Termostato
 TS: Termostato seguridad
 TRP:Termopar
 VG: Válvula gas

E: Allumage
 IG: Interrupteur général
 Ip: Micro sécurité
 L1: Veilleuse mise en route
 L2: Veilleuse chauffage
 T: Thermostat
 TS: Thermostat sécurité
 TRP:Termocouple
 VG:Valve gaz

E: Igniter
 IG: Main switch
 IP: Security switch
 L1: On light
 L2: Heating light
 T: Thermostat
 TS: Security thermostat
 TRP:Thermo couple
 VG:Gas valve

E: Start
 IG: Hauptschalter
 IP: Mikro-Sicherheitsschalter
 L1: Funktionleuchte
 L2: Erwärmungleuchte
 T: Thermostat
 TS: Sicherheitsthermostat
 TRP:Termometer
 VG: Gasventil

E: Ignitore
 IG: Interruttore generale
 IP: Micro sicurezza
 L1: Lampada funzionamento
 L2: Lampada riscaldamento
 T: Termostato
 TS: Termostato di sicurezza
 TRP:Coppia termoelettrica
 VG: Válvula del gas

X-153022

Esquema teórico			X-153022		
Nº	Pieza	Cant.	Material	Nº Clasificación	Acabado
Nº	Modificación	Propuesta de		Fecha	Tolerancias generales
					$\leq 5\pm$: $50-100\pm$: $5-25\pm$: $> 100\pm$: $25-50\pm$: $\infty\pm$
Dibujado	Firma	Fecha	 Fagor Industrial, Koop. Elk. Mugatua		Mecanizado superficial
Proyectado	KONTXI	10/1/2001			
Comprobado					
Escala	SARTEN BASCULANTE				Plano numero HC-75428
Plano hau ez daiteke erabil ez beriz la gura bainari tz gabe					Sustituye al Nº Sustituido por

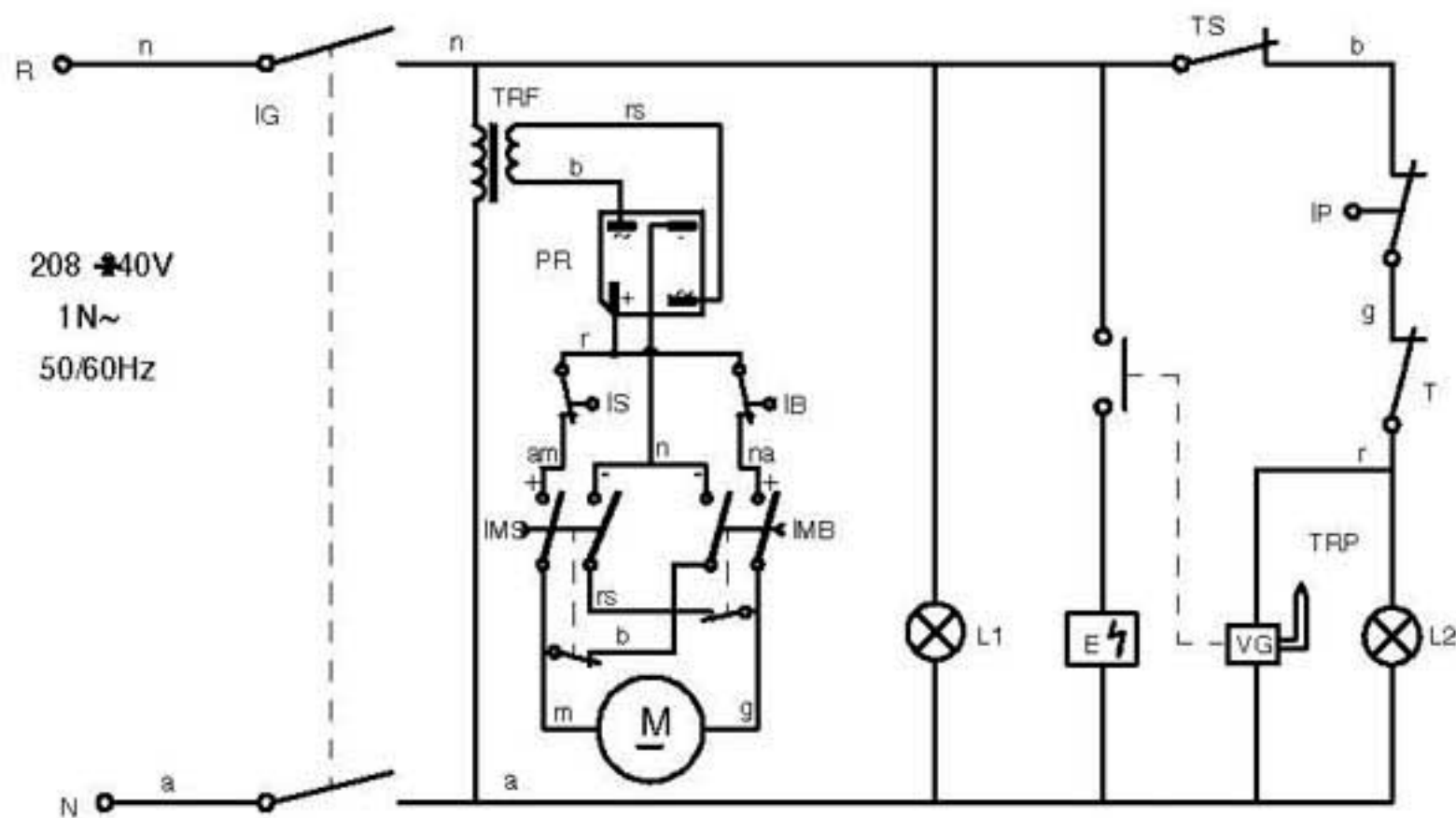

SBG9-10M, SBG9-15

a: azul	a: bleu	a: blue	a: blow	a: azzurra
m: marron	m: marron	m: brown	m: braun	m: marrone
n: negro	n: noir	n: black	n: shwarz	n: nero
r: rojo	r: rouge	r: red	r: rot	r: rosso
b: blanco	b: blanc	b: white	b: weiss	b: bianco
g: gris	g: gris	g: grey	g: grau	g: grigio
rs: rosa	rs: rose	rs: pink	rs: rosa	rs: rosa
am: amarillo	am: jaune	am: yellow	am: gelb	am: giallo
na: naranja	na: orange	na: orange	na: orange	na: arancione
ve: verde	ve: vert	ve: green	ve: grün	ve: verde

E: Encendedor
 VG: Válvula gas
 IB: Micro tope bajada
 IG: Interruptor general
 IMB: Pulsador bajada
 IMS: Pulsador subida
 IP: Micro seguridad
 IS: Micro tope subida
 L1: Lámpara marcha
 L2: Lámpara calentamiento
 M: Motor
 PR: Puente rectificador
 T: Termostato
 TRF: Transformador
 TS: Termostato seguridad
 TRP: Termopar

E: Allumage
 VG: Valve gaz
 IB: Micro bride descende
 IG: Interrupteur général
 IMB: Commande de baisse
 IMS: Commande de montée
 Ip: Micro sécurité
 Is: Micro bride montée
 L1: Veilleuse mise en route
 L2: Veilleuse chauffage
 M: Moteur
 PR: Pont redlicateur
 T: Thermostat
 TRF: Transformateur
 TS: Thermostat sécurité
 TRP: Thermocouple

E: Igniter
 VG: Gas valve
 IB: Descént tops witch
 IG: Main switch
 IMB: Descent switch
 IMS: Elevation switch
 IP: Security switch
 IS: Elevating top switch
 L1: On light
 L2: Heating light
 M: Motor
 PR: Rectifier bridge
 T: Thermostat
 TRF: Transformer
 TS: Security thermostat
 TRP: Thermo couple

E: Start
 VG: Gasventil
 IB: Mikro-Schalter unten
 IG: Hauptschalter
 IMB: Kippschalter unten
 IMS: Kippschalter oben
 IP: Mikro-Sicherheitsschalter
 IS: Mikro-Schalter oben
 L1: Funktionsleuchte
 L2: Erwärmungsleuchte
 M: Motor
 PR: Richtleiterüberbrückung
 T: Thermostat
 TRF: Transformator
 TS: Sicherheitsthermostat
 TRP: Thermometer

E: Ignitore
 VG: Valvola del gas
 IB: Micro arresto discesa
 IG: Interruttore generale
 IMB: Pulsante discesa
 IMS: Pulsante salita
 IP: Micro sicurezza
 IS: Micro arresto salita
 L1: Lampada funzionamento
 L2: Lampada riscaldamento
 M: Motore
 PR: Ponte rettificatore
 T: Termostato
 TRF: Trasformatore
 TS: Termostato di sicurezza
 TRP: Coppia termoelettrica

X-343023

Esquema teórico			X-343023		
Nº	Pieza	Cart.	Material	Nº Clasificación	Acabado
Nº	Modificación		Propuesta de	Fecha	Tolerancias generales
					<5± : 50-100± : 5-25± : >100± 25-50± : O±
Dibujado		Firma	Fecha	 Mecanizado superficial	
Proyectado		KONTXI	10/1/2001		
Comprobado					
Escala		Fagor Industrial, Koop. Elk., Mugatua			Plano numero
SARTEN BASCULANTE				HC-75426	
				Sustituye al Nº	
Plano hau ez ditek e era bil ez berizta gure baimon iz gabe				Sustituido por	

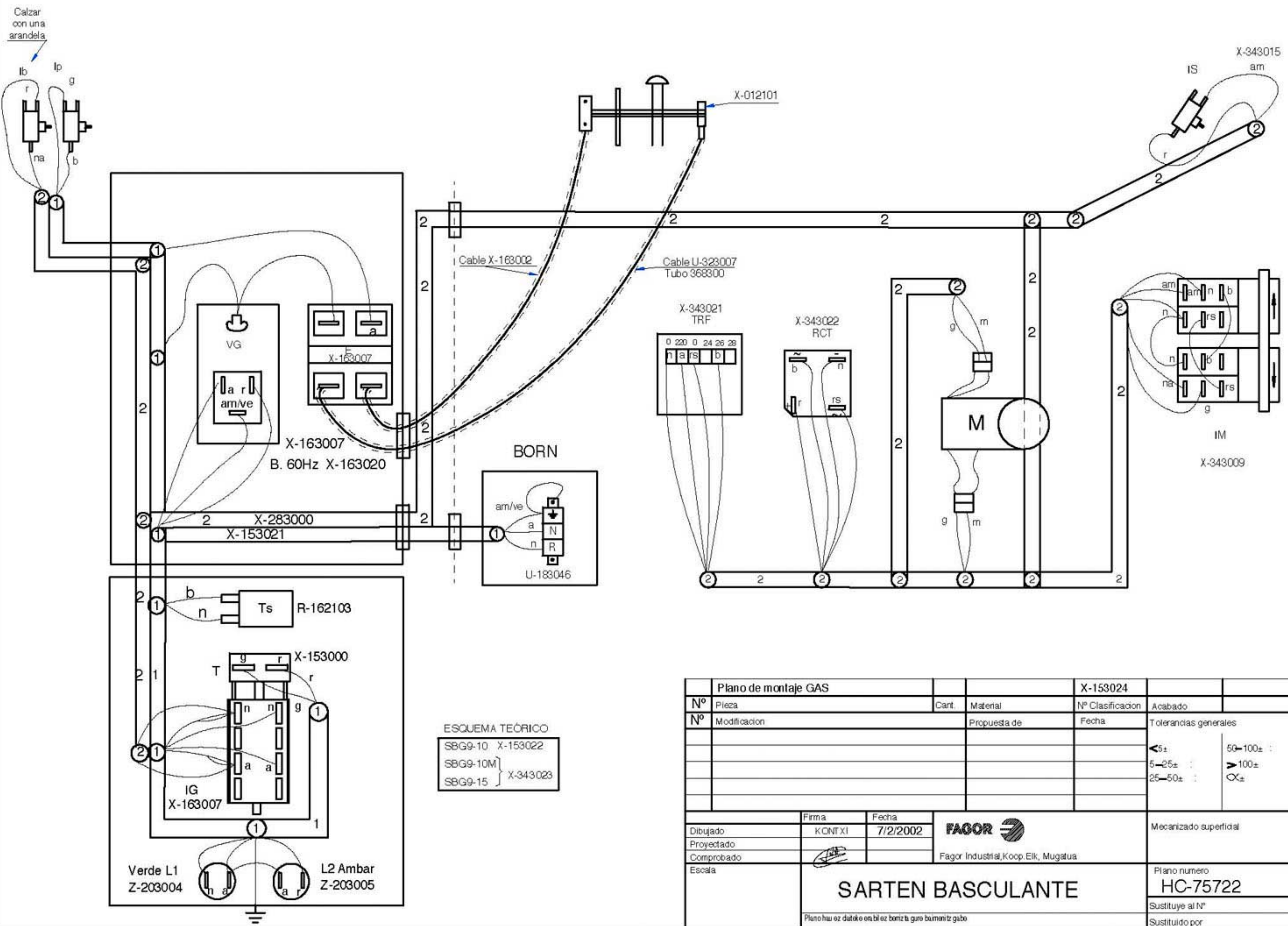

Plano de montaje GAS			X-153024		
Nº	Pieza	Carf.	Material	Nº Clasificación	Acabado
Nº	Modificación	Propuesta de		Fecha	Tolerancias generales
					$\leq 5\pm$: $50-100\pm$: 5-25± : > 100± : 25-50± : $\infty\pm$:
Dibujado		Firma	Fecha	 Fagor Industrial, Koop. Eik, Mugatua	
Proyectado		KONTXI	7/2/2002		
Comprobado					
Escala					
SARTEN BASCULANTE					Plano numero
Plano hau ez datske erabil ez beriz la gure bumeriz gabe					HC-75722
					Sustituye al Nº
					Sustituido por

SBE9-10,SBE-710

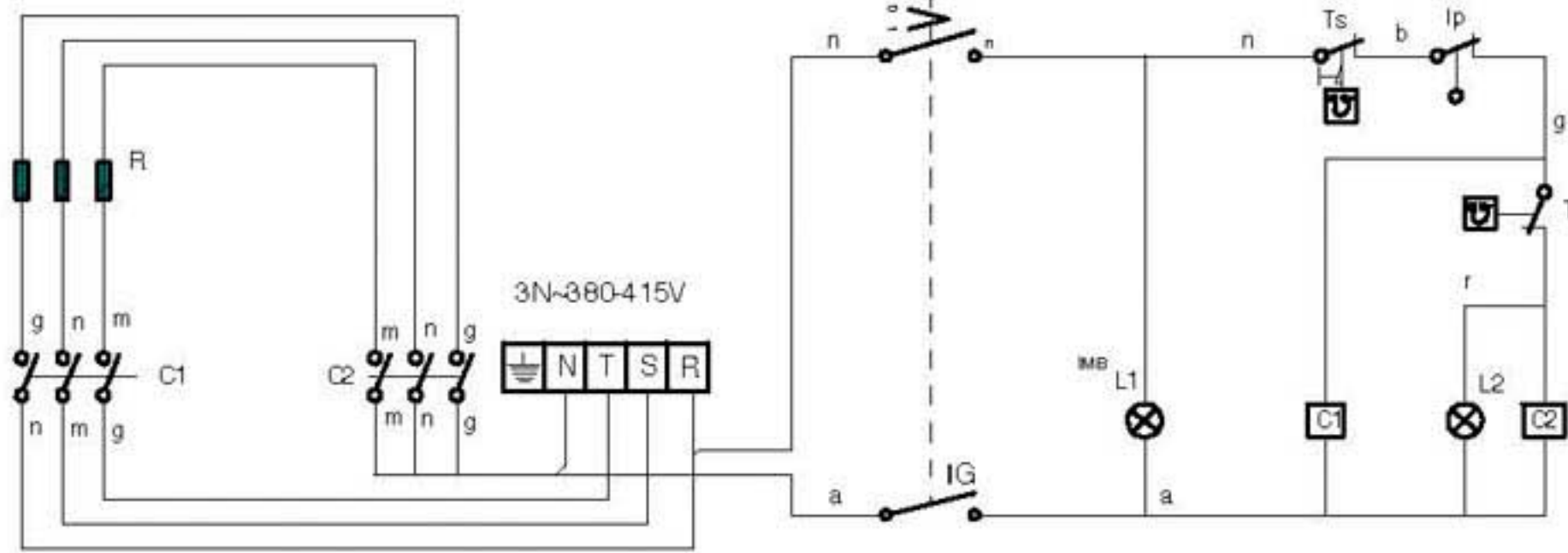

- | | | | | |
|--------------|------------|------------|------------|--------------|
| a: azul | a: bleu | a: blue | a: blau | a: azzurra |
| m: marron | m: marron | m: brown | m: braun | m: marrone |
| n: negro | n: noir | n: black | n: schwarz | n: nero |
| r: rojo | r: rouge | r: red | r: rot | r: rosso |
| b: blanco | b: blanc | b: white | b: weiss | b: bianco |
| g: gris | g: gris | g: grey | g: grau | g: grigio |
| rs: rosa | rs: rose | rs: pink | rs: rosa | rs: rosa |
| am: amarillo | am: jaune | am: yellow | am: gelb | am: giallo |
| na: naranja | na: orange | na: orange | na: orange | na: arandone |
| ve: verde | ve: vert. | ve: green | ve: grün | ve: verde |

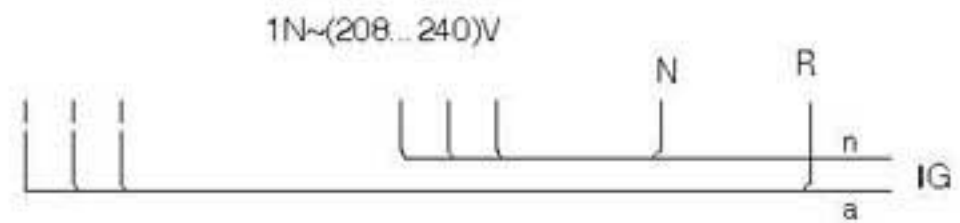
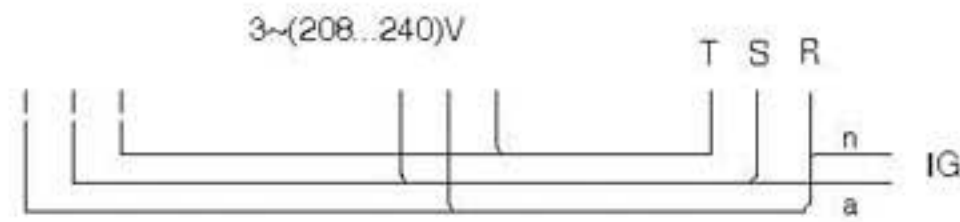

- | | | | | |
|--------------------------------|-----------------------------|-------------------------|-------------------------------|---------------------------------|
| C1,C2: Contactor calentamiento | C1,C2: Contacteur chauffage | C1,C2: Heating relay | C1,C2: Aufheizkontakt | C1,C2: Contattore riscaldamento |
| IG: Interruptor general | IG: Interrupteur général | IG: Main switch | IG: Hauptschalter | IG: Interruttore generale |
| IP: Micro seguridad | IP: Micro sécurité | IP: Security switch | IP: Mikro-Sicherheitsschalter | IP: Micro sicurezza |
| L1: Lampara marcha | L1: Veilleuse mise en route | L1: On light | L1: Funktionsleuchte | L1: Lampada funzionamento |
| L2: Lampara calentamiento | L2: Veilleuse chauffage | L2: Heating light | L2: Erwärmungsleuchte | L2: Lampada riscaldamento |
| R: Resistencia calentamiento | R: Résistance chauffage | R: Heating element | R: Heizsystem | R: Resistenza riscaldamento |
| T: Termostato | T: Thermostat | T: Thermostat | T: Thermostat | T: Termostato |
| TS: Termostato seguridad | TS: Thermostat sécurité | TS: Security thermostat | TS: Sicherheitsthermostat | TS: Termostato di sicurezza |

X-143006

Esquema teórico SBE		Poliester mate	X-143006	
Nº	Pieza	Cart.	Material	Nº Clasificación
Nº	Modificación	Propuesta de		Fecha
				Tolerancias generales
				$5\pm$: $50-100\pm$ $5-25\pm$: > $100\pm$ $25-50\pm$: $\infty\pm$
Dibujado	Firma	Fecha	 Fagor Industrial, Koop. Elk. Mugatua	
Proyectado	KONTXI	9/5/2001		
Comprobado				
Escala	SARTEN BASCULANTE			Plano numero
				HC-75709
				Sustituye al Nº
				Sustituido por

SBE9-10M

SBE9-15

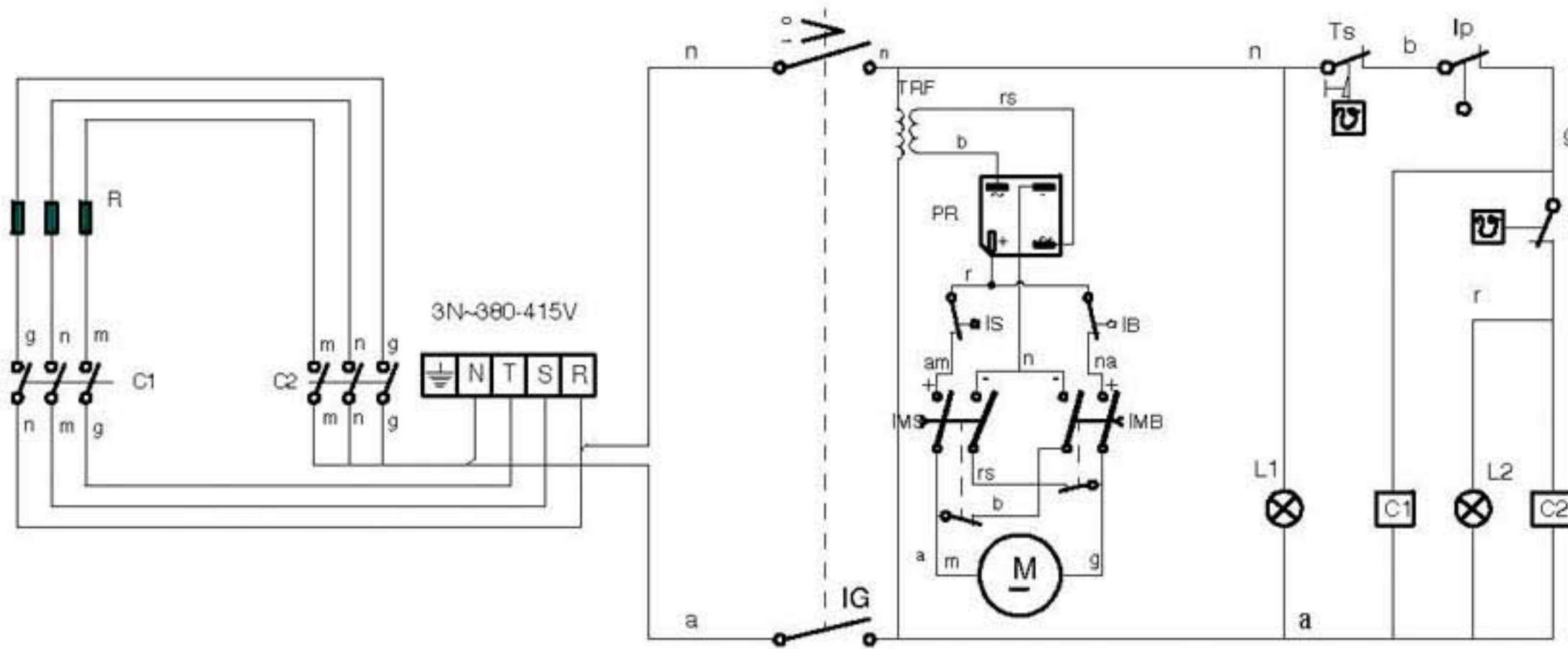

- | | | | | |
|--------------|------------|------------|------------|---------------|
| a: azul | a: bleu | a: blue | a: blau | a: azzurra |
| m: marron | m: marron | m: brown | m: braun | m: marrone |
| n: negro | n: noir | n: black | n: schwarz | n: nero |
| r: rojo | r: rouge | r: red | r: rot | r: rosso |
| b: blanco | b: blanc | b: white | b: weiss | b: bianco |
| g: gris | g: gris | g: grey | g: grau | g: grigio |
| rs: rosa | rs: rose | rs: pink | rs: rosa | rs: rosa |
| am: amarillo | am: jaune | am: yellow | am: gelb | am: giallo |
| na: naranja | na: orange | na: orange | na: orange | na: arancione |
| ve: verde | ve: vert | ve: green | ve: grün | ve: verde |

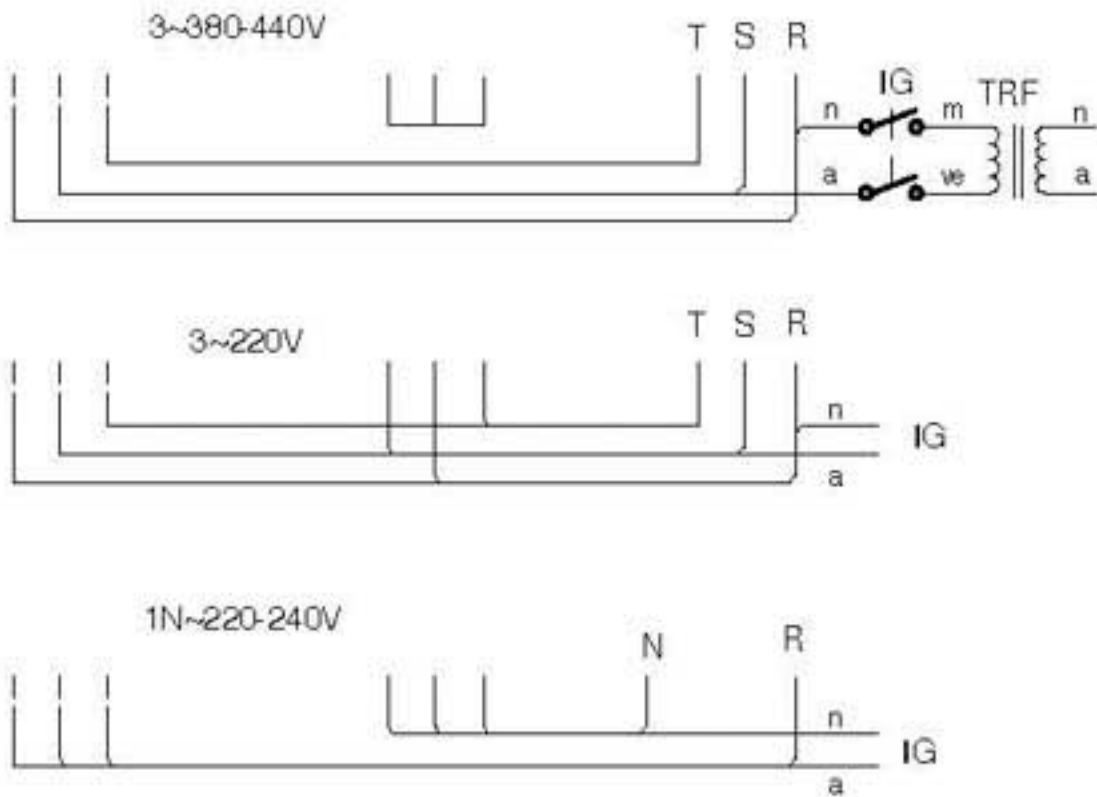

- | | | | | |
|--------------------------------|-----------------------------|--------------------------|-------------------------------|---------------------------------|
| C1,C2: Contactor calentamiento | C1,C2: Contacteur chauffage | C1,C2: Heating relay | C1,C2: Aufheizkontakt | C1,C2: Contattore riscaldamento |
| IB: Micro tope bajada | IB: Micro bride descente | IB: Descèrt tops witch | IB: Mikro-Schalter unten | IB: Micro arresto discesa |
| IG: Interruptor general | IG: Interrupteur général | IG: Main switch | IG: Hauptschalter | IG: Interruttore generale |
| IMB: Pulsador bajada | IMB: Commande de baisse | IMB: Descent switch | IMB: Kippschalter unten | IMB: Pulsante discesa |
| IMS: Pulsador subida | IMS: Commande de montée | IMS: Elevation switch | IMS: Kippschalter oben | IMS: Pulsante salita |
| IP: Micro seguridad | Ip: Micro sécurité | IP: Security switch | IP: Mikro-Sicherheitsschalter | IP: Micro sicurezza |
| IS: Micro tope subida | Is: Micro bride montée | IS: Elevating top switch | IS: Mikro-Schalter oben | IS: Micro arresto salita |
| L1: Lampara marcha | L1: Veilleuse mise en route | L1: On light | L1: Funktionsleuchte | L1: Lampada funzionamento |
| L2: Lampara calentamiento | L2: Veilleuse chauffage | L2: Heating light | L2: Erwärmungsleuchte | L2: Lampada riscaldamento |
| M: Motor | M: Moteur | M: Motor | M: Motor | M: Motore |
| PR: Puente rectificador | PR: Pont rectificateur | PR: Rectifier bridge | PR: Richtleiterüberbrückung | PR: Ponte rettificatore |
| R: Resistencia calentamiento | R: Résistance chauffage | R: Heating element | R: Heizsystem | R: Resistenza riscaldamento |
| T: Termostato | T: Thermostat | T: Thermostat | T: Thermostat | T: Termostato |
| TRF: Transformador | TRF: Transformateur | TRF: Transformer | TRF: Transformator | TRF: Trasformatore |
| TS: Termostato seguridad | TS: Thermostat sécurité | TS: Security thermostat | TS: Sicherheitsthermostat | TS: Termostato di sicurezza |

X-403002

Esquema teórico SBEM		Poliester mate	X-403002							
Nº	Pieza	Cont.	Material	Nº Clasificación						
Nº	Modificación	Propuesta de		Fecha						
				Tolerancias generales						
				<table border="0"> <tr> <td><5±</td> <td>50-100±</td> </tr> <tr> <td>5-25±</td> <td>>100±</td> </tr> <tr> <td>25-50±</td> <td>∞±</td> </tr> </table>	<5±	50-100±	5-25±	>100±	25-50±	∞±
<5±	50-100±									
5-25±	>100±									
25-50±	∞±									
Dibujado	KONTXI	Fecha	9/5/2001	Mecanizado superficial						
Proyectado		FAGOR								
Comprobado		Fagor Industrial, Koop. Elk. Mugatua								
Escala	SARTEN BASCULANTE			Plano numero						
Plano hau ez daiteke erabili ez beriz ta gure bumeritz gabe				HC-75708						
				Sustituye al Nº						
				Sustituido por						

Calzar con una arandela

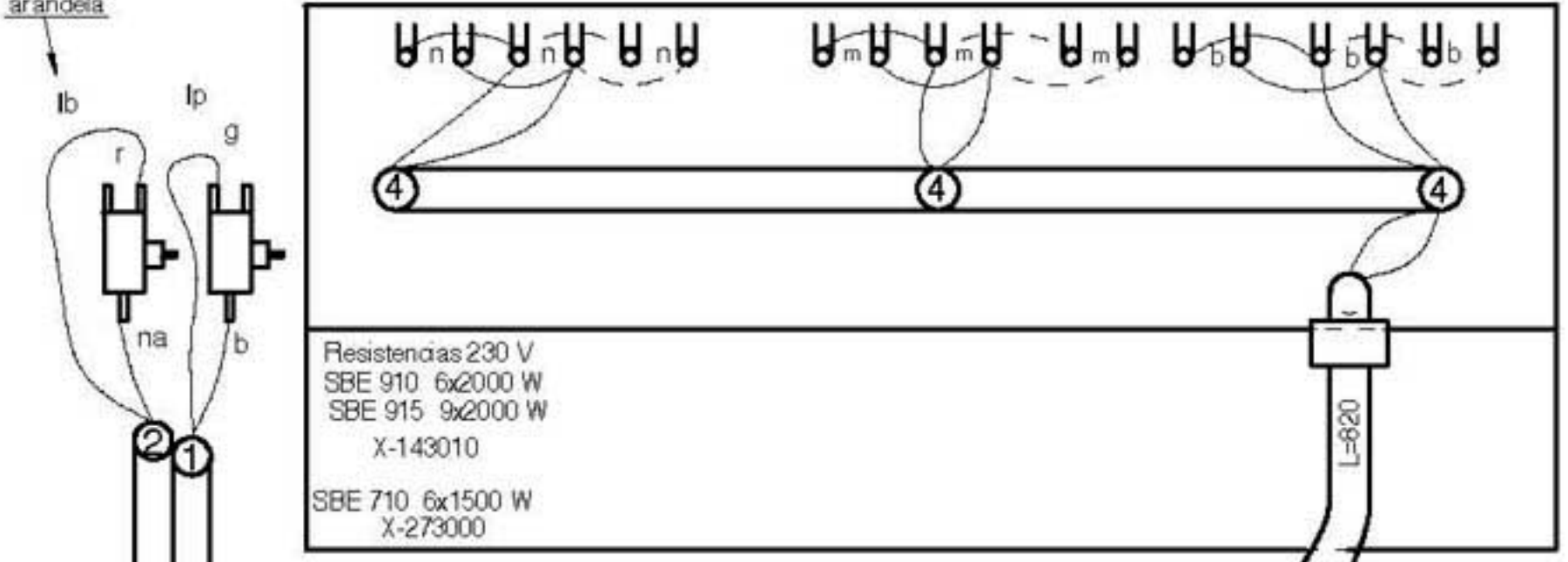

Resistencias 230 V
 SBE 910 6x2000 W
 SBE 915 9x2000 W
 X-143010
 SBE 710 6x1500 W
 X-273000

Instalación	SBE x10	SBE 915
1	X-143015	
2	X-283000	
3	X-143016	X-423005
4	X-143004	X-423004

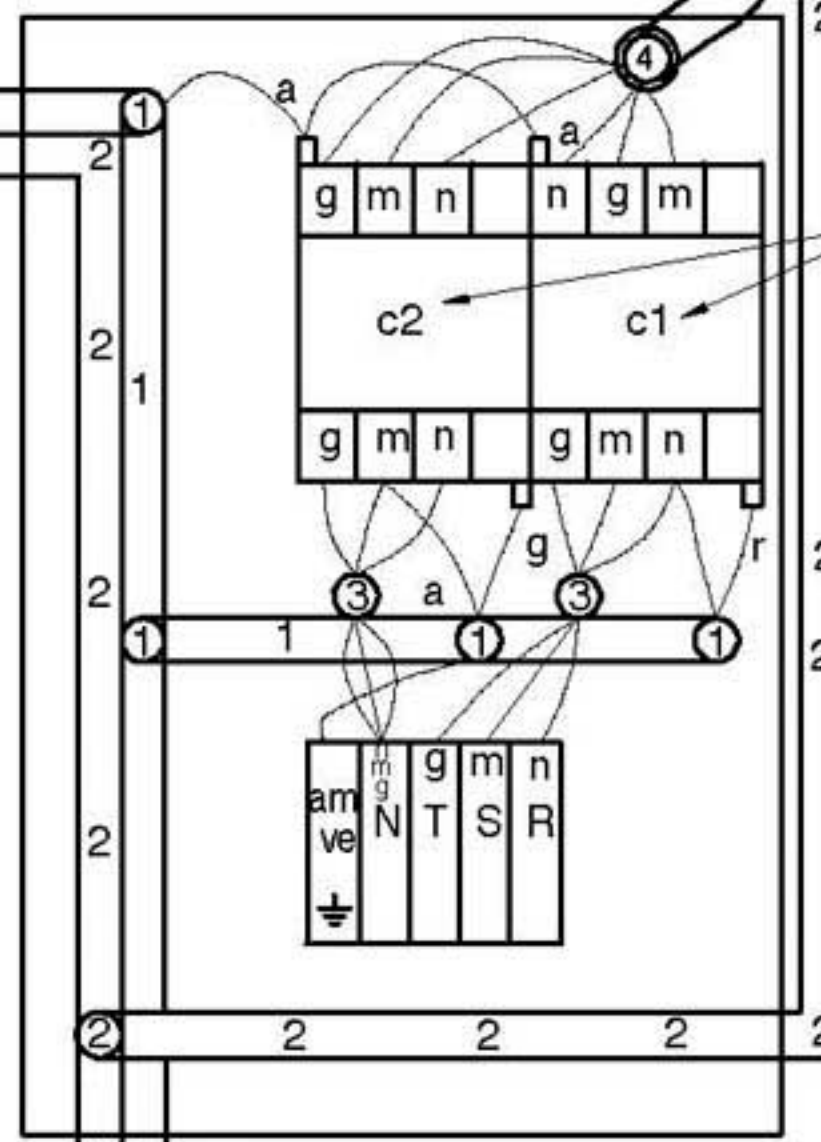
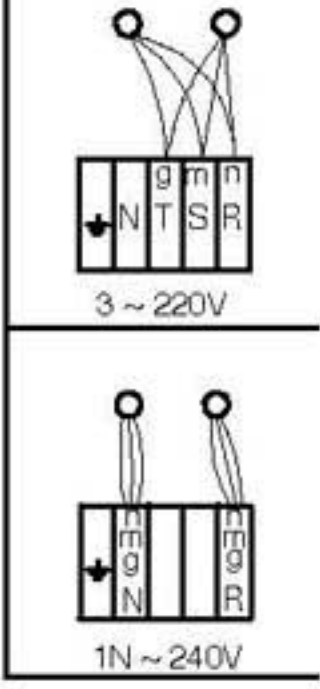
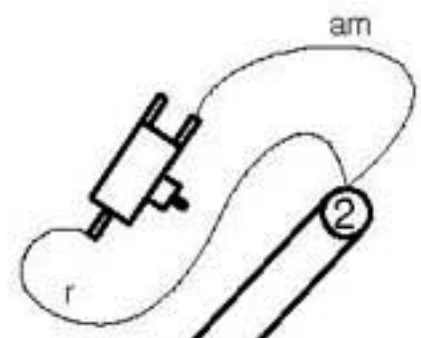

SBE X10 R-663031
 SBE 915 X-183011

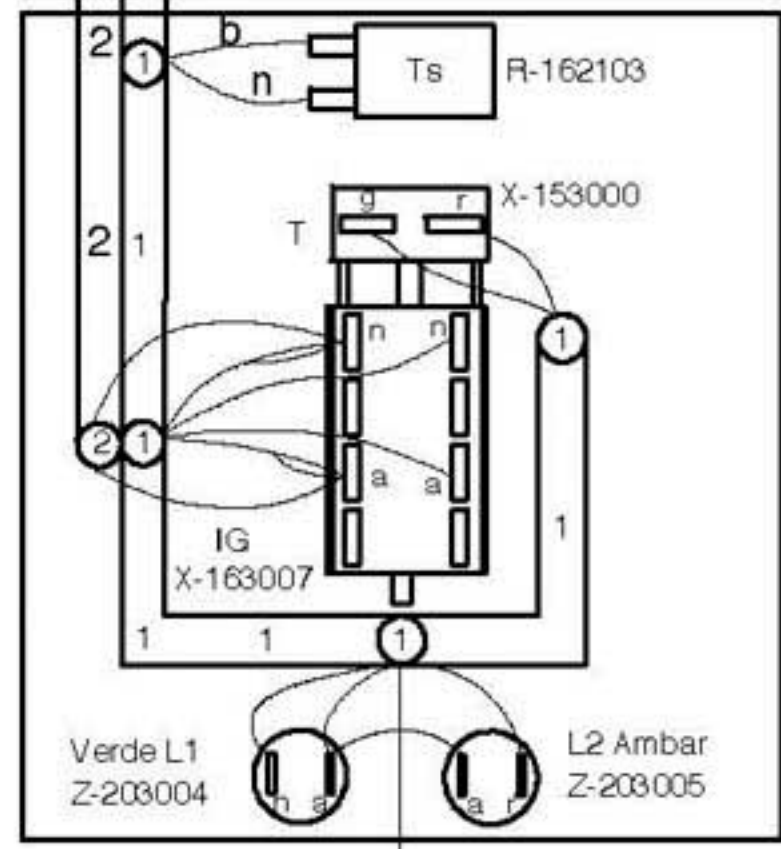
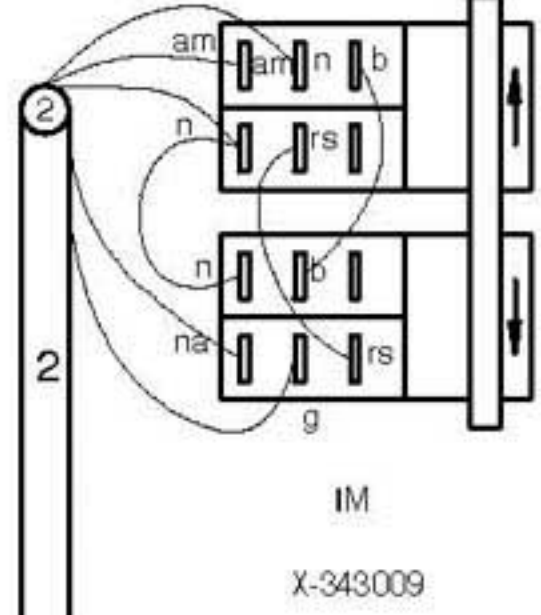
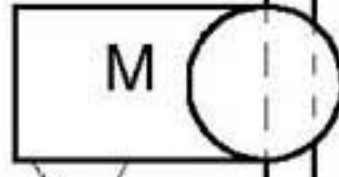
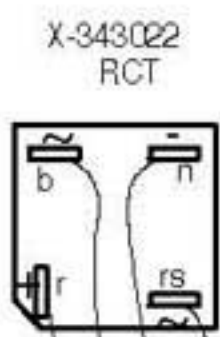
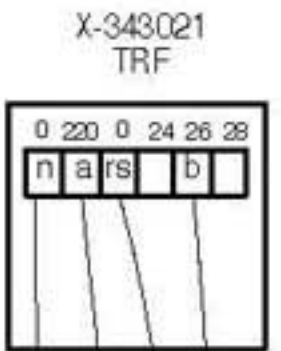

Verde L1 Z-203004
 L2 Ambar Z-203005

Esquema de montaje electrico			X-143005		
Nº	Pieza	Cart.	Material	Nº Clasificacion	Acabado
Nº	Modificacion	Propuesta de		Fecha	Tolerancias generales
					<5± : 50-100± 5-25± : >100± 25-50± : ∞±
Dibujado	Firma	Fecha	 Fagor Industrial, Koop. Elk. Mugatua		
Proyectado	KONTXI	18/01/2002			
Comprobado					
Escala					
SARTEN BASCULANTE				Mecanizado superficial	
				Plano numero HC-75713	
				Sustituye al Nº	
				Sustituido por	

Plano hau ez duteko esan ez beriz ta gure baimonizgabe