

**Marmitas a Gas Presión
Gas Pressure Boiling Pans
Marmites à Gaz Presión
Gas Kochkessel
Pentole a Gas**

Gama 900

Modelos:

MPG9-10 // MPG9-15 // MPG9-20

Junio 2001 June



Fagor Industrial

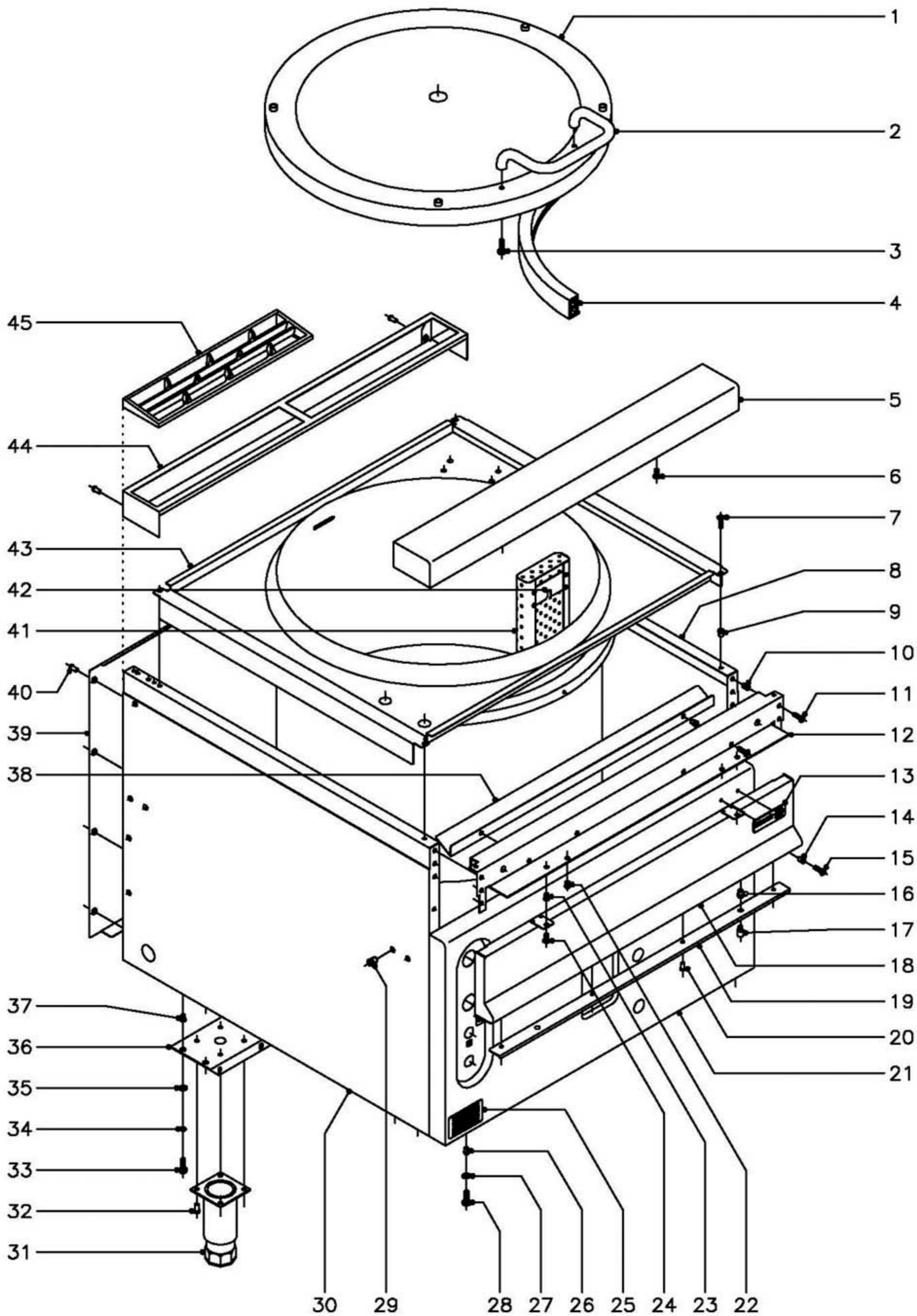

MOD.

MARMITAS

ZONA

MUEBLE

PLANO

C-1054

ITEM	CODIGO	DENOMINACION	TEXTO	MPG9-10	MPG9-15	MPG9-20	MPG9-10 S	MPG9-15 S	MPG9-20 S				NOTAS
1	S056137	Tapa		1	1	1	1	1	1				
2	S036123	Asa de tapa		1	1	1	1	1	1				
3	Q012053	Tornillo exagonal M-8x20		2	2	2	2	2	2				
4	S056109	Junta tapa		1	1	1	1	1	1				
5	R165431	Anterior de mesa		1	1	1	1	1	1				
6	Q152004	Tornillo aplastado M-5x13		2	2	2	2	2	2				
7	Q152004	Tornillo aplastado M-5x13		4	4	4	4	4	4				
8	X162811	Panel lateral derecho		1	1	1	-	-	-				
8	X192805	Panel lateral derecho		-	-	-	1	-	-				
8	S372812	Panel lateral derecho		-	-	-	-	1	1				
9	Q221342	Remache exagonal M-5		4	4	4	4	4	4				
10	Q221342	Remache exagonal M-5		6	6	6	6	6	6				
11	Q152004	Tornillo aplastado M-5x13		6	6	6	6	6	6				
12	R162613	Escuadra amarre anterior mesa		1	1	1	1	1	1				
13	U262806	Escudo FAGOR		1	1	1	1	1	1				
	Q221023	Clips sujecion escudo		2	2	2	2	2	2				
14	Q221342	Remache exagonal M-5		2	2	2	2	2	2				
15	Q152004	Tornillo aplastado M-5x13		2	2	2	2	2	2				
16	Q221343	Remache exagonal M-6		1	1	1	1	1	1				
17	Q151336	Tornillo soporte guia		1	1	1	1	1	1				
18	S032806	Panel portamandos		1	1	1	1	1	1				
19	S032807	Protector		1	1	1	1	1	1				
20	Q419005	Remache tubular Ø4x8		4	4	4	4	4	4				
21	S012802	Panel frontal		1	-	-	-	-	-				
21	S062810	Panel frontal		-	-	-	1	-	-				
21	S032802	Panel frontal		-	1	-	-	1	-				
21	S272801	Panel frontal		-	-	1	-	-	1				
22	Q221342	Remache exagonal M-5		2	2	2	2	2	2				
23	Q221342	Remache exagonal M-5		2	2	2	2	2	2				

MOD.

MARMITAS

ZONA

MUEBLE

PLANO

C-1054

ITEM	CODIGO	DENOMINACION	TEXTO	MPG9-10	MPG9-15	MPG9-20	MPG9-10 S	MPG9-15 S	MPG9-20 S				NOTAS
24	Q152004	Tornillo aplastado M-5x13		2	2	2	2	2	2				
25	S326540	Papel polyester 65x118		1	1	1	1	1	1				Placa matricula
26	Q221343	Remache exagonal M-6		2	2	2	2	2	2				
27	Q302022	Arandela plana Ø16xØ6x1,2		2	2	2	2	2	2				
28	Q012042	Tornillo exagonal M-6x15		2	2	2	2	2	2				
29	Q221343	Remache exagonal M-6		14	14	14	14	14	14				
30	X162810	Panel lateral izquierdo		1	1	1	-	-	-				
30	X192803	Panel lateral izquierdo		-	-	-	1	-	-				
30	S372810	Panel lateral izquierdo		-	-	-	-	1	1				
31	X260150	Pata regulable		4	4	4	-	-	-				
32	Q411304	Remache avibulb Ø4,8		16	16	16	-	-	-				
33	Q012042	Tornillo exagonal M-6x15		8	8	8	-	-	-				
34	Q162040	Arandela muelle A-6		8	8	8	-	-	-				
35	Q302022	Arandela plana Ø16xØ6x1,2		8	8	8	-	-	-				
36	S032631	Liston soporte patas		2	2	2	-	-	-				
37	Q221343	Remache exagonal M-6		8	8	8	-	-	-				
38	S032645	Escuadra aislante calor		1	1	1	1	1	1				
	Q221342	Remache exagonal M-5		2	2	2	2	2	2				
	Q152004	Tornillo aplastado M-5x13		2	2	2	2	2	2				
39	U562853	Panel posterior		1	1	1	-	-	-				
39	X242817	Panel posterior		-	-	-	1	-	-				
39	S372816	Panel posterior		-	-	-	-	1	1				
40	Q419005	Remache tubular Ø4x8		8	8	8	8	8	8				
41	S016145	Filtro de cuba		1	-	-	1	-	-				
41	S036145	Filtro de cuba		-	1	1	-	1	1				
42	S036117	Soporte filtro		2	2	2	2	2	2				
	Q412000	Remache tubular Ø4x8		8	8	8	8	8	8				
43	S196150	Cuba de 100 l.		1	-	-	1	-	-				
43	S056150	Cuba de 150 l.		-	1	-	-	1	-				

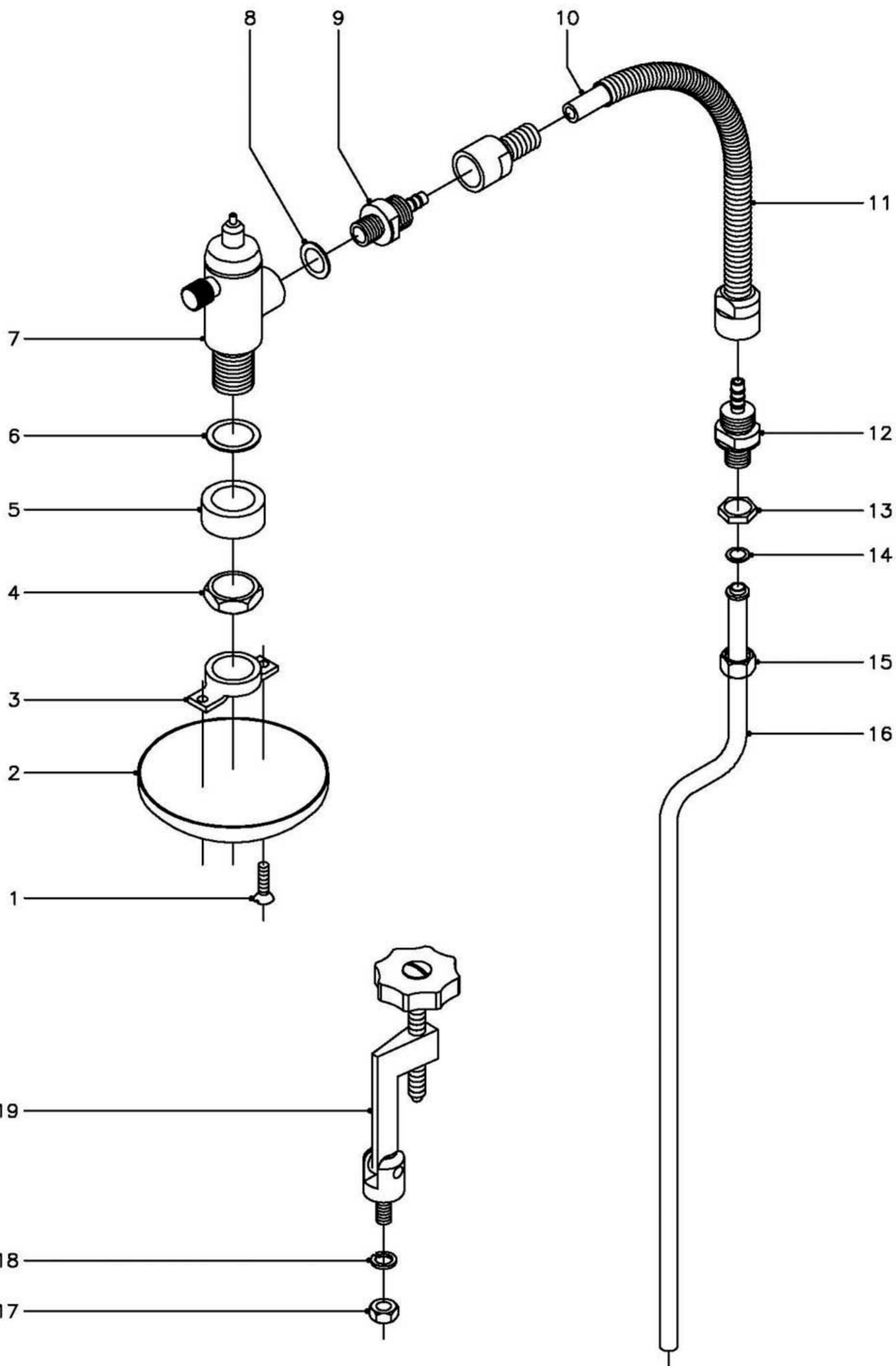

MOD.

MARMITAS

ZONA

VALVULA Y TIRANTES TAPA

PLANO

C-1055

ITEM	CODIGO	DENOMINACION	TEXTO	MPG9-10	MPG9-15	MPG9-20	MPG9-10 S	MPG9-15 S	MPG9-20 S				NOTAS
1	Q152024	Tornillo avellanado M-4x8		2	2	2	2	2	2				
2	S102116	Cubierta valvula		1	1	1	1	1	1				
3	S102115	Tuerca de cubierta valvula		1	1	1	1	1	1				
4	Q223014	Tuerca 1"		1	1	1	1	1	1				
5	S102114	Casquillo suplemento		1	1	1	1	1	1				
6	Q306037	Arandela junta Ø42,5xØ32x1,5		1	1	1	1	1	1				
7	S102101	Valvula seguridad de cuba		1	1	1	1	1	1				
8	Q306038	Arandela junta Ø31xØ21x1,5		1	1	1	1	1	1				
9	S102122	Manguito union valvula a tubo		1	1	1	1	1	1				
10	3676900	Tubo de goma Ø17xØ10x500		1	1	1	1	1	1				
11	S052102	Conduccion flexible completa		1	1	1	1	1	1				
12	S102122	Manguito union valvula a tubo		1	1	1	1	1	1				
13	Q221302	Tuerca exagonal 1/2"		1	1	1	1	1	1				
14	Q306024	Arandela junta Ø18xØ12,5x1,5		1	1	1	1	1	1				
15	Q223010	Tuerca 1/2"		1	1	1	1	1	1				
16	S135000	Salida de espumas		1	1	1	1	1	1				
17	Q162070	Tuerca exagonal M-12		4	4	4	4	4	4				
18	Q261570	Arandela muelle A-12		4	4	4	4	4	4				
19	S052101	Tirante cierre tapa		4	4	4	4	4	4				

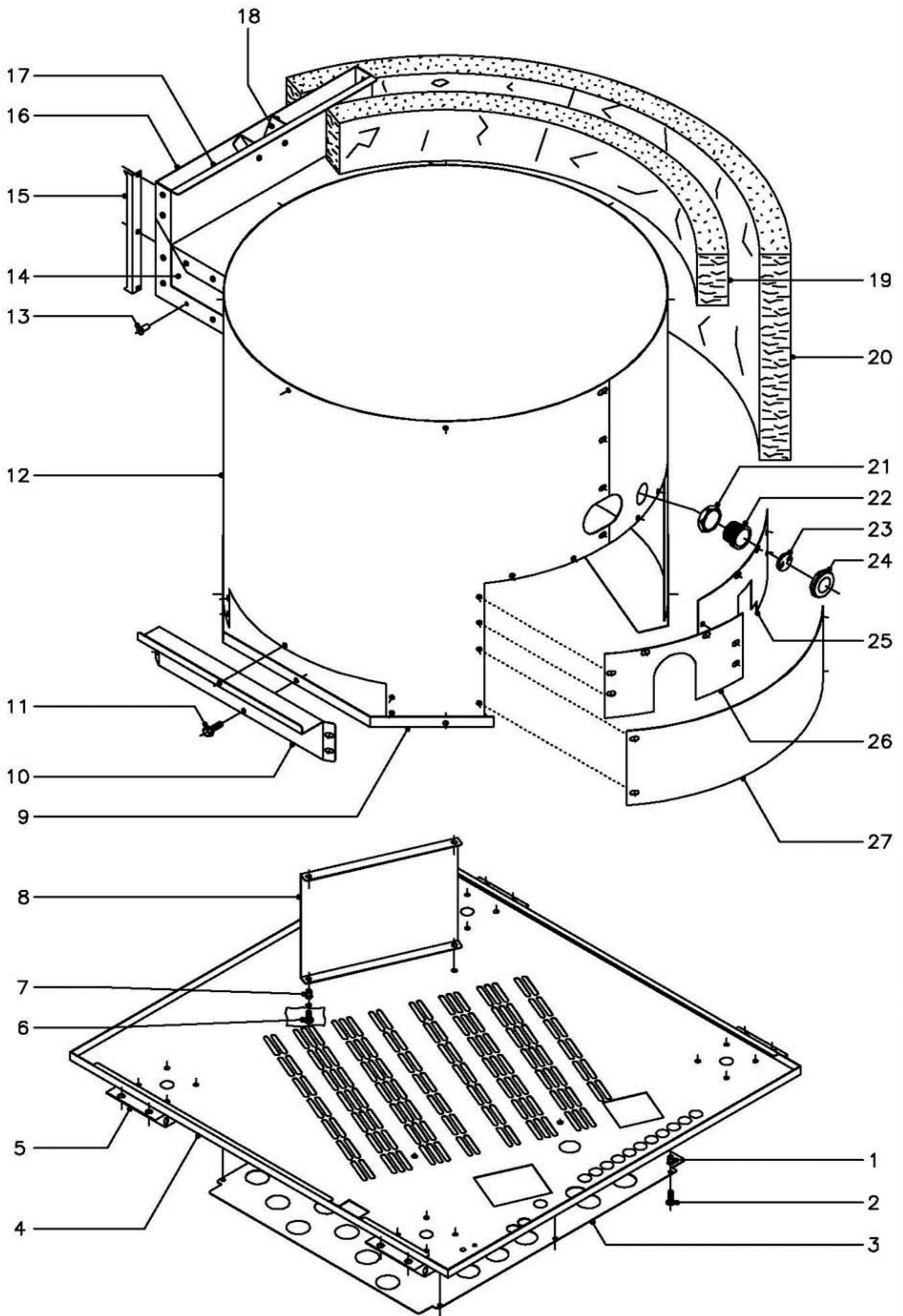

N plano	Firma	Fecha	Aparato	PIEZAS INTERIORES	Lamina	Fagor Industrial S.Coop. FAGOR
C-1056		6-2001	MARMITAS	MPG9-10, 15, 20	3	Oñate

MOD.

MARMITAS

ZONA

PIEZAS INTERIORES

PLANO

C-1056

ITEM	CODIGO	DENOMINACION	TEXTO	MPG9-10	MPG9-15	MPG9-20	MPG9-10 S	MPG9-15 S	MPG9-20 S				NOTAS
1	Q221342	Remache exagonal M-5		-	-	6	-	-	-				
2	Q152004	Tornillo aplastado M-5x13		-	-	6	-	-	-				
3	S272610	Proteccion suelo		-	-	1	-	-	-				
4	S272606	Base inferior		1	1	1	-	-	-				
4	S062811	Base inferior		-	-	-	1	-	-				
4	S372814	Base inferior		-	-	-	-	1	1				
5	S032631	Liston soporte patas		2	2	2	-	-	-				
6	Q012031	Tornillo exagonal M-5x10		4	4	4	4	4	4				
7	Q221342	Remache exagonal M-5		4	4	4	4	4	4				
8	S012616	Soporte quemador		2	-	-	-	-	-				
8	S032639	Soporte quemador		-	2	-	-	2	-				
8	S062606	Soporte quemador		-	-	-	2	-	-				
9	S032636	Cierre de envolvente		1	1	-	1	1	-				
9	S042625	Cierre de envolvente		-	-	1	-	-	1				
10	S272609	Cierre lateral envolvente		-	-	2	-	-	2				
11	Q151323	Tornillo broca M-4,8x16		30	30	30	30	30	35				
12	S012615	Envolvente		1	-	-	-	-	-				
12	S032635	Envolvente		-	1	-	-	1	-				
12	S272605	Envolvente		-	-	1	-	-	1				
12	S062605	Envolvente		-	-	-	1	-	-				
13	Q419005	Remache tubular Ø4x8		24	24	24	24	24	24				
14	S032641	Amarre lateral chimenea		2	2	-	2	2	-				
14	S042631	Amarre lateral chimenea		-	-	2	-	-	2				
15	X162657	Distanciador de chimenea		2	2	2	2	2	2				
16	S032644	Posterior de chimenea		1	1	-	1	1	-				
16	S042628	Posterior de chimenea		-	-	1	-	-	1				
17	S032643	Anterior de chimenea		1	1	-	1	1	-				
17	S042629	Anterior de chimenea		-	-	1	-	-	1				
18	S035400	Protector chimenea		1	1	1	1	1	1				

ITEM	CODIGO	DENOMINACION	TEXTO	MPG9-10	MPG9-15	MPG9-20	MPG9-10 S	MPG9-15 S	MPG9-20 S				NOTAS
19	S116403	Aislante 1300x100x50		1	1	1	1	1	1				
20	R092622	Aislante 1370x650x20		2	2	2	2	2	2				
21	Q223014	Tuerca exagonal 1"		1	1	1	1	1	1				
22	9294500	Portamirilla		1	1	1	1	1	1				
23	9294600	Mirilla cristal		1	1	1	1	1	1				
24	9294400	Tuerca cierre		1	1	1	1	1	1				
25	S032637	Tapa cierre derecho		1	1	-	1	1	-				
25	S272607	Tapa cierre derecho		-	-	1	-	-	1				
26	S032638	Tapa cierre izquierdo		1	1	-	1	1	-				
26	S272608	Tapa cierre izquierdo		-	-	1	-	-	1				
27	S012617	Tapa inferior		1	-	-	-	-	-				
27	S062607	Tapa inferior		-	-	-	1	-	-				

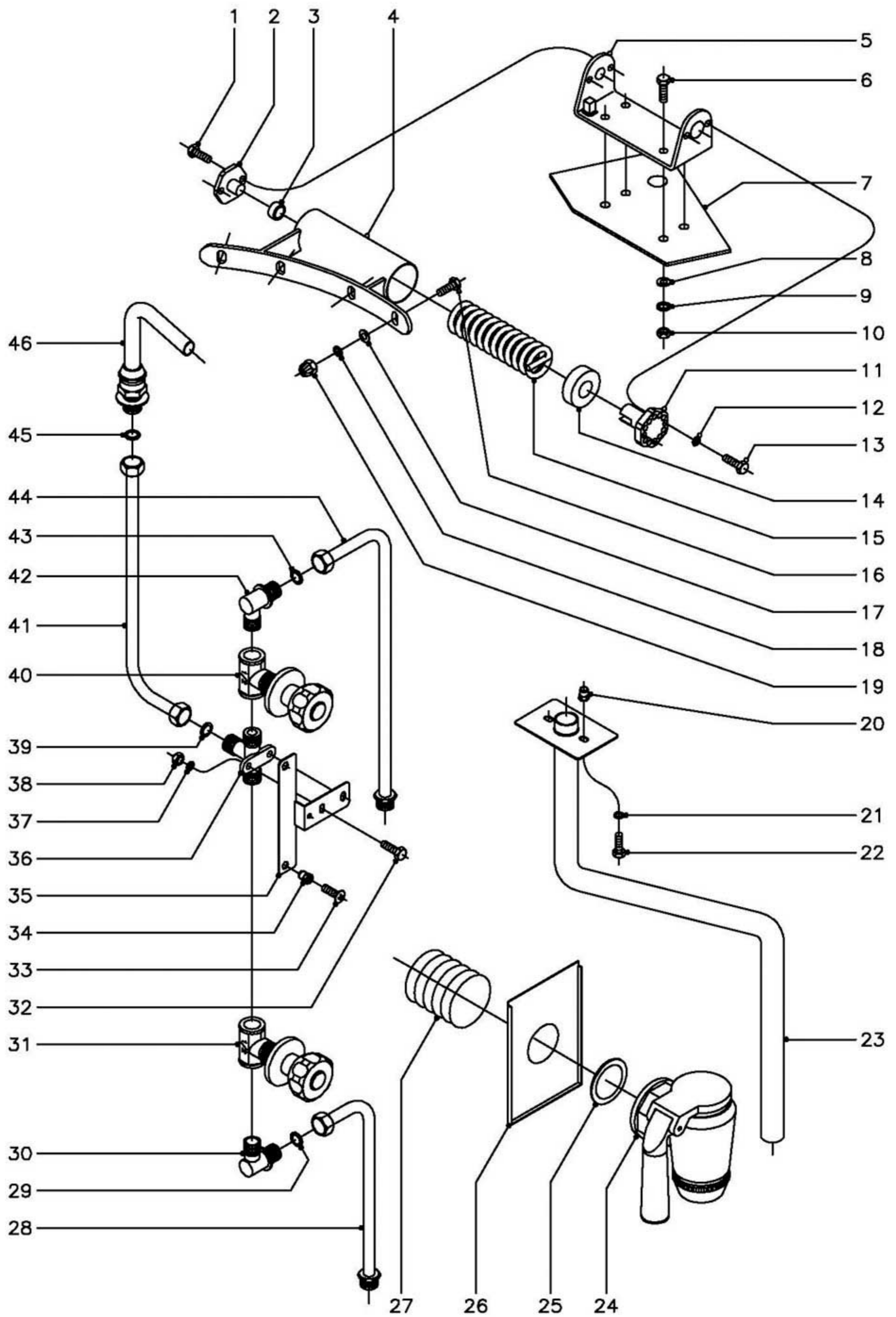

N plano
C-1057

Firma

Fecha
6-2001

Aparato TOMAS DE AGUA, DESAGUES Y BISAGRA TAPA
MARMITAS MPG9-10, 15, 20

Lamina
4

Fager Industrial S.Coop. **FAGOR**
Oñate

MOD.

MARMITAS

ZONA

TOMAS DE AGUA, DESAGÜES Y BISAGRA TAPA

PLANO

C-1057

ITEM	CODIGO	DENOMINACION	TEXTO	MPG9-10	MPG9-15	MPG9-20	MPG9-10 S	MPG9-15 S	MPG9-20 S				NOTAS
1	Q012041	Tornillo exagonal M-6x10		2	2	2	2	2	2				
2	S116119	Giro de asa		1	1	1	1	1	1				
3	S116126	Cojinete cilindrico		1	1	1	1	1	1				
4	S036143	Bisagra tapa		1	1	1	1	1	1				
4	S036146	Bisagra tapa (Para cuscusera)		1	1	1	-	-	-				
5	S036131	Soporte de bisagra		1	1	1	1	1	1				
6	Q012055	Tornillo exagonal M-8x30		4	4	4	4	4	4				
7	S026102	Refuerzo bisagra		1	1	1	1	1	1				
8	Q232050	Arandela plana A-8		4	4	4	4	4	4				
9	Q262050	Arandela muelle A-8		4	4	4	4	4	4				
10	Q162050	Tuerca exagonal M-8		4	4	4	4	4	4				
11	S116120	Tensor resorte		1	1	1	1	1	1				
12	Q262040	Arandela muelle A-6		2	2	2	2	2	2				
13	Q012042	Tornillo exagonal M-6x15		2	2	2	2	2	2				
14	S116118	Casquillo		1	1	1	1	1	1				
15	S116121	Resorte tapa		1	1	1	1	1	1				
16	Q012053	Tornillo exagonal M-8x20		4	4	4	4	4	4				
17	Q232050	Arandela plana A-8		4	4	4	4	4	4				
18	Q262050	Arandela muelle A-8		4	4	4	4	4	4				
19	Q212051	Tuerca sombrerete M-8		4	4	4	4	4	4				
20	Q221342	Remache exagonal M-5		2	2	2	2	2	2				
21	Q262030	Arandela muelle A-5		2	2	2	2	2	2				
22	Q012032	Tornillo exagonal M-5x15		2	2	2	2	2	2				
23	S036119	Tubo vaciado		1	1	1	-	1	1				
23	S065004	Tubo vaciado		-	-	-	1	-	-				
24	S112150	Grifo de vaciado		1	1	1	1	1	1				
25	S112152	Junta grifo vaciado		1	1	1	1	1	1				
26	S112803	Cubierta de grifo		1	1	1	1	1	1				
27	S112105	Muelle soporte cubierta		1	1	1	1	1	1				

ITEM	CODIGO	DENOMINACION	TEXTO	MPG9-10	MPG9-15	MPG9-20	MPG9-10 S	MPG9-15 S	MPG9-20 S				NOTAS
28	S035036	Conducto entrada agua inferior		1	1	1	-	-	-				
28	S065020	Conducto entrada agua inferior		-	-	-	1	-	-				
28	S375007	Conducto entrada agua inferior		-	-	-	-	1	1				
29	Q306024	Arandela junta Ø18xØ12,5x1,5		1	1	1	1	1	1				
30	S115013	Codo		1	1	1	1	1	1				
31	S112151	Llave de paso con mando (fria)		1	1	1	1	1	1				
32	Q012042	Tornillo exagonal M-6x15		2	2	2	2	2	2				
33	Q152004	Tornillo aplastado M-5x13		2	2	2	2	2	2				
34	Q221342	Remache exagonal M-5		2	2	2	2	2	2				
35	S032640	Soporte grifos de agua		1	1	1	1	1	1				
36	S205022	Racord union de grifos		1	1	1	1	1	1				
37	Q262040	Arandela muelle A-6		2	2	2	2	2	2				
38	Q162040	Tuerca exagonal M-6		2	2	2	2	2	2				
39	Q306024	Arandela junta Ø18xØ12,5x1,5		1	1	1	1	1	1				
40	S112154	Llave de paso con mando (calien.)		1	1	1	1	1	1				
41	S035032	Conducto grifos a base		1	1	1	1	1	1				
42	S115013	Codo		1	1	1	1	1	1				
43	Q306024	Arandela junta Ø18xØ12,5x1,5		1	1	1	1	1	1				
44	S035035	Conducto entrada agua superior		1	1	1	-	-	-				
44	S065018	Conducto entrada agua superior		-	-	-	1	-	-				
44	S345010	Conducto entrada agua superior		-	-	-	-	1	1				
45	Q306024	Arandela junta Ø18xØ12,5x1,5		1	1	1	1	1	1				
46	S052100	Tubo de llenado		1	1	1	1	1	1				

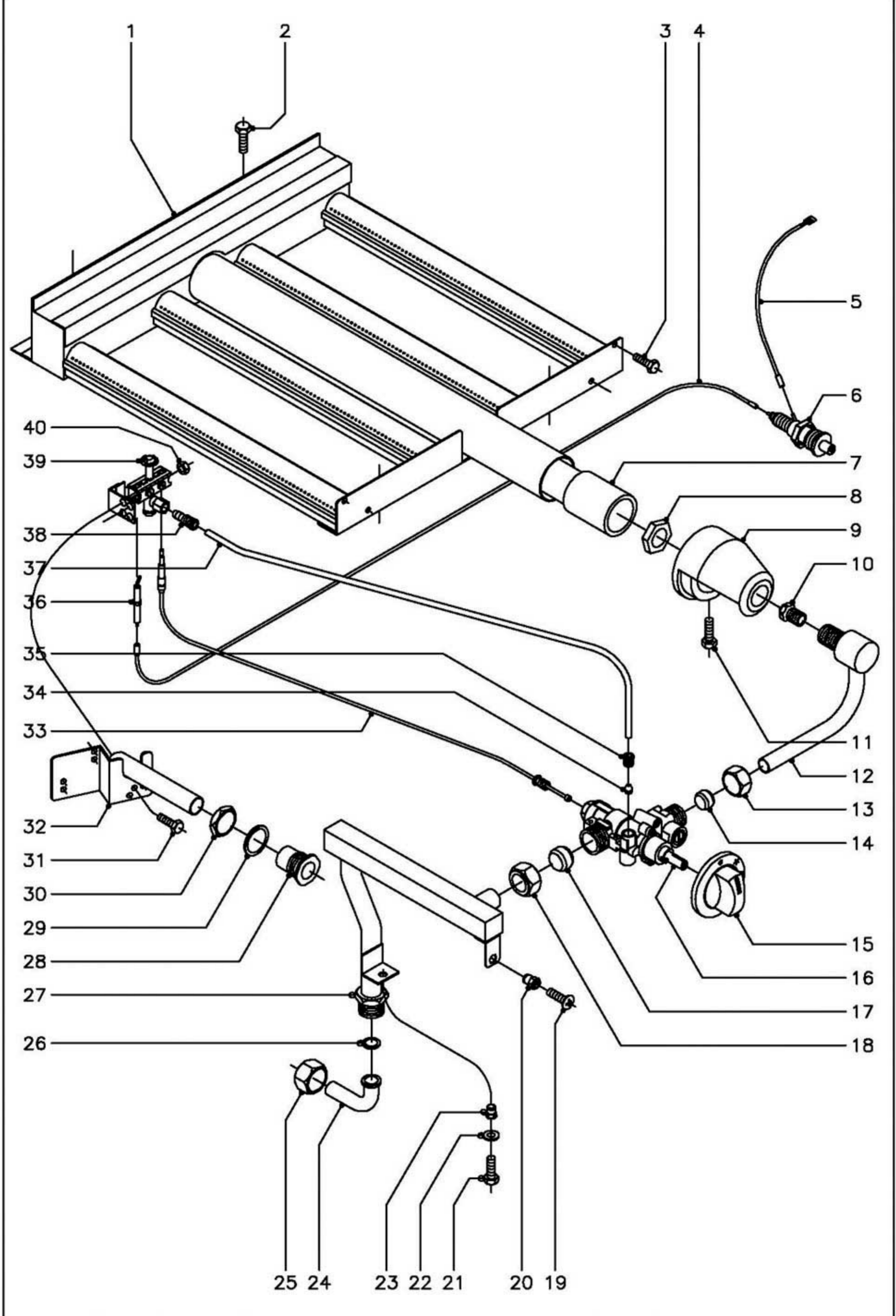

MOD.

MARMITAS

ZONA

PARTE FUNCIONAL GAS

PLANO

C-1058

ITEM	CODIGO	DENOMINACION	TEXTO	MPG9-10	MPG9-15	MPG9-20	MPG9-10 S	MPG9-15 S	MPG9-20 S				NOTAS
1	S275705	Quemador		1	1	1	1	1	1				
2	Q012031	Tornillo exagonal M-5x10		4	4	4	4	4	4				
3	Q012031	Tornillo exagonal M-5x10		2	2	2	2	2	2				
4	U323030	Cable bujia a piezoelectrico		1	1	1	1	1	1				
5	U333003	Cable masa a piezoelectrico		1	1	1	1	1	1				
6	S113034	Piezoelectrico		1	1	1	1	1	1				
7	S135733	Venturi		1	1	1	1	1	1				
8	Q221302	Tuerca exagonal 1/2"		1	1	1	1	1	1				
9	628100	Camara de mezcla		1	1	1	1	1	1				
10	S012400	Tobera Ø2,20 (Butano-Propano)		1	-	-	1	-	-				
10	S032400	Tobera Ø2,45 (Butano-Propano)		-	1	-	-	1	-				
10	S172400	Tobera Ø2,55 (Butano-Propano)		-	-	1	-	-	1				
10	S012401	Tobera Ø3,10 (Gas Natural)		1	-	-	1	-	-				
10	S114401	Tobera Ø3,65 (Gas Natural)		-	1	-	-	1	-				
10	S114400	Tobera Ø3,80 (Gas Natural)		-	-	1	-	-	1				
10	S012402	Tobera Ø5,90 (Gas Villa)		1	-	-	1	-	-				
10	S032401	Tobera Ø6,90 (Gas Villa)		-	1	-	-	1	-				
10	S172402	Tobera Ø7,75 (Gas Villa)		-	-	1	-	-	1				
11	Q012043	Tornillo exagonal M-6x20		1	1	1	1	1	1				
12	S015010	Conduccion a quemador		1	-	-	1	-	-				
12	S035025	Conduccion a quemador		-	1	-	-	1	-				
12	S045025	Conduccion a quemador		-	-	1	-	-	1				
13	S312105	Tuerca fijacion conduc.a quemador		1	1	1	1	1	1				
14	S312106	Bicono Ø16		1	1	1	1	1	1				
15	S312110	Boton de mando Ø10		1	1	1	1	1	1				
16	S312101	Grifo SC. PEL-23S. V (min. Ø1,40)		1	1	1	1	1	1				
17	S312104	Bicono Ø20		1	1	1	1	1	1				
18	S312103	Tuerca fijacion conduc. General		1	1	1	1	1	1				
19	Q152004	Tornillo aplastado M-5x13		1	1	1	1	1	1				

MOD.

MARMITAS

ZONA

PARTE FUNCIONAL GAS

PLANO

C-1058

ITEM	CODIGO	DENOMINACION	TEXTO	MPG9-10	MPG9-15	MPG9-20	MPG9-10 S	MPG9-15 S	MPG9-20 S				NOTAS
20	Q221342	Remache exagonal M-5		1	1	1	1	1	1				
21	Q012042	Tornillo exagonal M-6x15		1	1	1	1	1	1				
22	Q302022	Arandela plana Ø16xØ6x1,2		1	1	1	1	1	1				
23	Q221343	Remache exagonal M-6		1	1	1	1	1	1				
24	U565007	Codo entrada gas		1	1	1	-	-	-				
25	U725006	Tuerca 3/4"		1	1	1	-	-	-				
26	Q306052	Arandela junta Ø23,5xØ15,5x3		1	1	1	-	-	-				
27	S035030	Conduccion general		1	1	1	-	-	-				
27	S065016	Conduccion general		-	-	-	1	-	-				
27	S035030	Conduccion general		-	-	-	-	1	1				
28	S112804	Embellededor tubo de encendido		1	1	1	1	1	1				
29	Q306027	Arandela junta Ø33,8xØ27x1,5		1	1	1	1	1	1				
30	Q221324	Tuerca exagonal 3/4"		1	1	1	1	1	1				
31	Q012031	Tornillo exagonal M-5x10		2	2	2	2	2	2				
32	S045028	Tubo de encendido		1	1	1	1	1	1				
33	U562130	Termopar L=850		1	1	1	1	1	1				
34	X205028	Bicono Ø 6		1	1	1	1	1	1				
35	S312107	Manguito tubo piloto		1	1	1	1	1	1				
36	X012101	Bujia de encendido		1	1	1	1	1	1				
37	S015012	Tubo piloto de 100 l.		1	-	-	1	-	-				
37	S035027	Tubo piloto de 150 l.		-	1	-	-	1	-				
37	S045027	Tubo piloto de 200 l.		-	-	1	-	-	1				
38	U134323	Racord con bicono Ø 6		1	1	1	1	1	1				
39	R202100	Conjunto soporte y piloto		1	1	1	1	1	1				
	U442138	Inyector piloto Ø 0,25 (B.P.y G.V.)		1	1	1	1	1	1				Regular para G.V.
	U442137	Inyector piloto Ø 0,40 (Gas Natural)		1	1	1	1	1	1				
40	Q162030	Tuerca exagonal M-5		2	2	2	2	2	2				

MOD.

MARMITAS

ZONA

VARIOS

PLANO

ITEM	CODIGO	DENOMINACION	TEXTO	MPG9-10	MPG9-15	MPG9-20	MPG9-10 S	MPG9-15 S	MPG9-20 S				NOTAS
	S036515	Folleto de instrucciones		1	1	1	1	1	1				

MOD.

MARMITAS

ZONA

PIEZAS ESPECIFICAS PARA LOS DISTINTOS GASES

PLANO

C-1058

ITEM	CODIGO	DENOMINACION	TEXTO	MPG9-10	MPG9-15	MPG9-20	MPG9-10 S	MPG9-15 S	MPG9-20 S				NOTAS
		<u>BUTANO - PROPANO</u>											
10	S012400	Tobera Ø 2,20		1	-	-	1	-	-				
10	S032400	Tobera Ø 2,45		-	1	-	-	1	-				
10	S172400	Tobera Ø 2,55		-	-	1	-	-	1				
39	U442138	Inyector piloto Ø 0,25		1	1	1	1	1	1				
s/n	U136501	Indicador (Butano - Propano)		1	1	1	1	1	1				
		<u>GAS NATURAL</u>											
10	S012401	Tobera Ø 3,10		1	-	-	1	-	-				
10	S114401	Tobera Ø 3,65		-	1	-	-	1	-				
10	S114400	Tobera Ø 3,80		-	-	1	-	-	1				
39	U442137	Inyector piloto Ø 0,40		1	1	1	1	1	1				
s/n	U134402	Indicador (Gas Natural)		1	1	1	1	1	1				
		<u>GAS VILLA</u>											
10	S012402	Tobera Ø 5,90		1	-	-	1	-	-				
10	S032401	Tobera Ø 6,90		-	1	-	-	1	-				
10	S172402	Tobera Ø 7,75		-	-	1	-	-	1				
39	U442138	Inyector piloto Ø 0,25		1	1	1	1	1	1				Regular para G.V.
s/n	U134310	Indicador (Gas Villa)		1	1	1	1	1	1				