

Marmitas a Gas
Gas Direct Heating Boiling Pans
Marmites à Gaz Feu Direct
Gas Kochkessel
Pentole a Gas

Gama 900

Modelos:

MG9-10 // MG9-15 // MG9-20

Junio 2001 June



Fagor Industrial

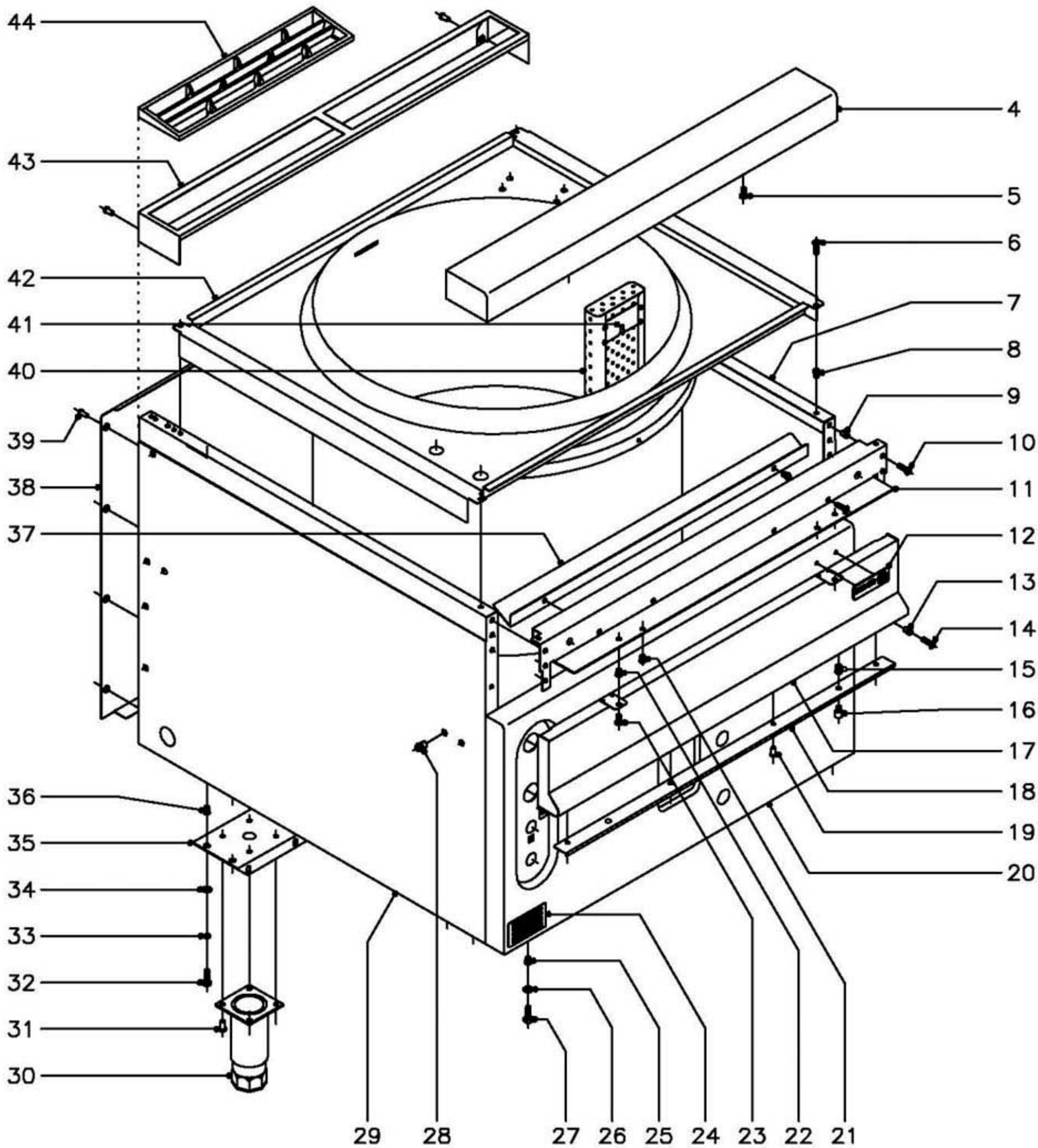
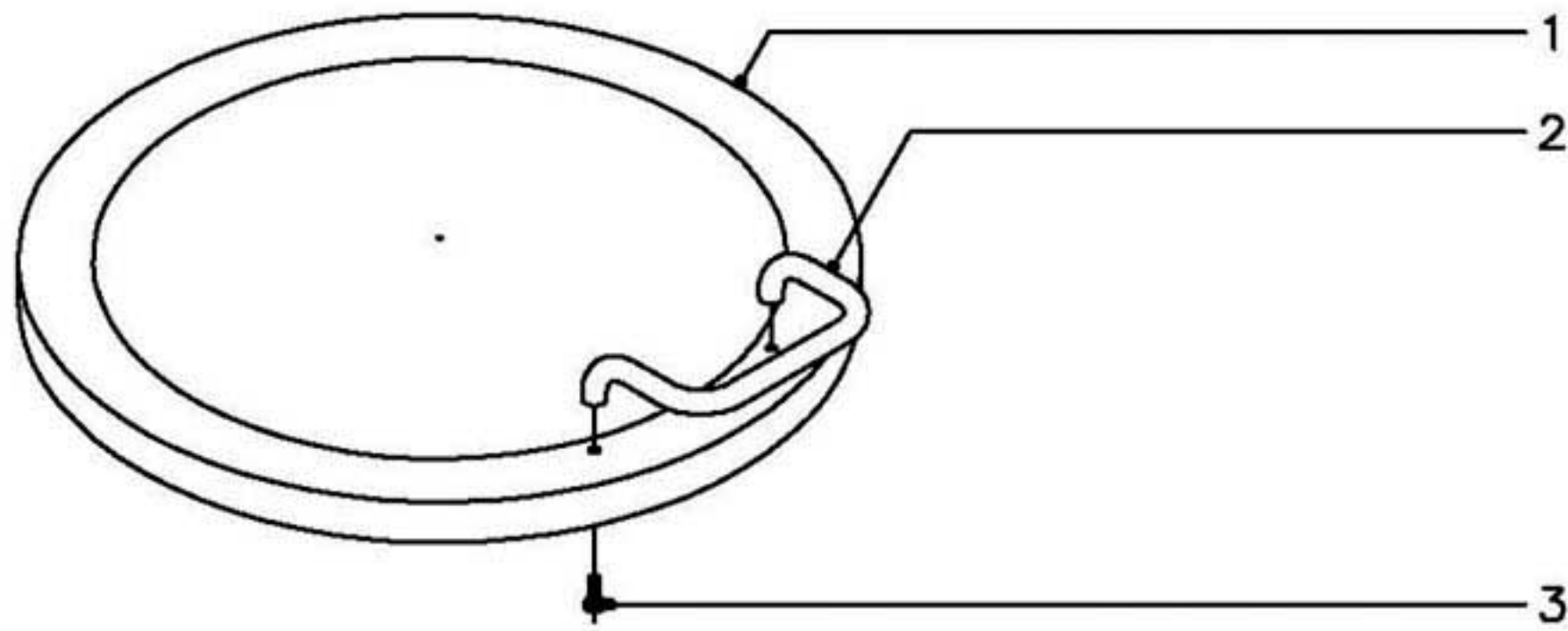

MOD.		MARMITAS		ZONA		MUEBLE						PLANO		C-1050	
ITEM	CODIGO	DENOMINACION	TEXTO	MG9-10	MG9-15	MG9-20	MG9-10 S	MG9-15 S	MG9-20 S					NOTAS	
1	S036141	Tapa		1	1	1	1	1	1						
2	S036123	Asa de tapa		1	1	1	1	1	1						
3	Q012053	Tornillo exagonal M-8x20		2	2	2	2	2	2						
4	R165431	Anterior de mesa		1	1	1	1	1	1						
5	Q152004	Tornillo aplastado M-5x13		2	2	2	2	2	2						
6	Q152004	Tornillo aplastado M-5x13		4	4	4	4	4	4						
7	X162811	Panel lateral derecho		1	1	1	-	-	-						
7	X192805	Panel lateral derecho		-	-	-	1	-	-						
7	S372812	Panel lateral derecho		-	-	-	-	1	1						
8	Q221342	Remache exagonal M-5		4	4	4	4	4	4						
9	Q221342	Remache exagonal M-5		6	6	6	6	6	6						
10	Q152004	Tornillo aplastado M-5x13		6	6	6	6	6	6						
11	R162613	Escuadra amarre anterior mesa		1	1	1	1	1	1						
12	U262806	Escudo FAGOR		1	1	1	1	1	1						
	Q221023	Clips sujecion escudo		2	2	2	2	2	2						
13	Q221342	Remache exagonal M-5		2	2	2	2	2	2						
14	Q152004	Tornillo aplastado M-5x13		2	2	2	2	2	2						
15	Q221343	Remache exagonal M-6		1	1	1	1	1	1						
16	Q151336	Tornillo soporte guia		1	1	1	1	1	1						
17	S032806	Panel portamandos		1	1	1	1	1	1						
18	S032807	Protector		1	1	1	1	1	1						
19	Q419005	Remache tubular Ø4x8		4	4	4	4	4	4						
20	S012802	Panel frontal		1	-	-	-	-	-						
20	S062810	Panel frontal		-	-	-	1	-	-						
20	S032802	Panel frontal		-	1	-	-	1	-						
20	S272801	Panel frontal		-	-	1	-	-	1						
21	Q221342	Remache exagonal M-5		2	2	2	2	2	2						
22	Q221342	Remache exagonal M-5		2	2	2	2	2	2						
23	Q152004	Tornillo aplastado M-5x13		2	2	2	2	2	2						

MOD.

MARMITAS

ZONA

MUEBLE

PLANO

C-1050

ITEM	CODIGO	DENOMINACION	TEXTO	MG9-10	MG9-15	MG9-20	MG9-10 S	MG9-15 S	MG9-20 S				NOTAS
24	S326540	Papel polyester 65x118		1	1	1	1	1	1				Placa matricula
25	Q221343	Remache exagonal M-6		2	2	2	2	2	2				
26	Q302022	Arandela plana Ø16xØ6x1,2		2	2	2	2	2	2				
27	Q012042	Tornillo exagonal M-6x15		2	2	2	2	2	2				
28	Q221343	Remache exagonal M-6		14	14	14	14	14	14				
29	X162810	Panel lateral izquierdo		1	1	1	-	-	-				
29	X192803	Panel lateral izquierdo		-	-	-	1	-	-				
29	S372810	Panel lateral izquierdo		-	-	-	-	1	1				
30	X260150	Pata regulable		4	4	4	-	-	-				
31	Q411304	Remache avibulb Ø4,8		16	16	16	-	-	-				
32	Q012042	Tornillo exagonal M-6x15		8	8	8	-	-	-				
33	Q162040	Arandela muelle A-6		8	8	8	-	-	-				
34	Q302022	Arandela plana Ø16xØ6x1,2		8	8	8	-	-	-				
35	S032631	Liston soporte patas		2	2	2	-	-	-				
36	Q221343	Remache exagonal M-6		8	8	8	-	-	-				
37	S032645	Escuadra aislante calor		1	1	1	1	1	1				
	Q221342	Remache exagonal M-5		2	2	2	2	2	2				
	Q152004	Tornillo aplastado M-5x13		2	2	2	2	2	2				
38	U562853	Panel posterior		1	1	1	-	-	-				
38	X242817	Panel posterior		-	-	-	1	-	-				
38	S372816	Panel posterior		-	-	-	-	1	1				
39	Q419005	Remache tubular Ø4x8		8	8	8	8	8	8				
40	S016145	Filtro de cuba		1	-	-	1	-	-				
40	S036145	Filtro de cuba		-	1	1	-	1	1				
41	S036117	Soporte filtro		2	2	2	2	2	2				
	Q412000	Remache tubular Ø4x8		8	8	8	8	8	8				
42	S016150	Cuba de 100 l.		1	-	-	1	-	-				
42	S036150	Cuba de 150 l.		-	1	-	-	1	-				
42	S276150	Cuba de 200 l.		-	-	1	-	-	1				

MOD.

MARMITAS

ZONA

MUEBLE

PLANO

C-1050

ITEM	CODIGO	DENOMINACION	TEXTO	MG9-10	MG9-15	MG9-20	MG9-10 S	MG9-15 S	MG9-20 S				NOTAS
43	R205428	Soporte embellecedor 1 M.		1	1	1	1	1	1				
	Q419005	Remache tubular Ø4x8		2	2	2	2	2	2				
44	R205425	Embellecedor chimenea		2	2	2	2	2	2				

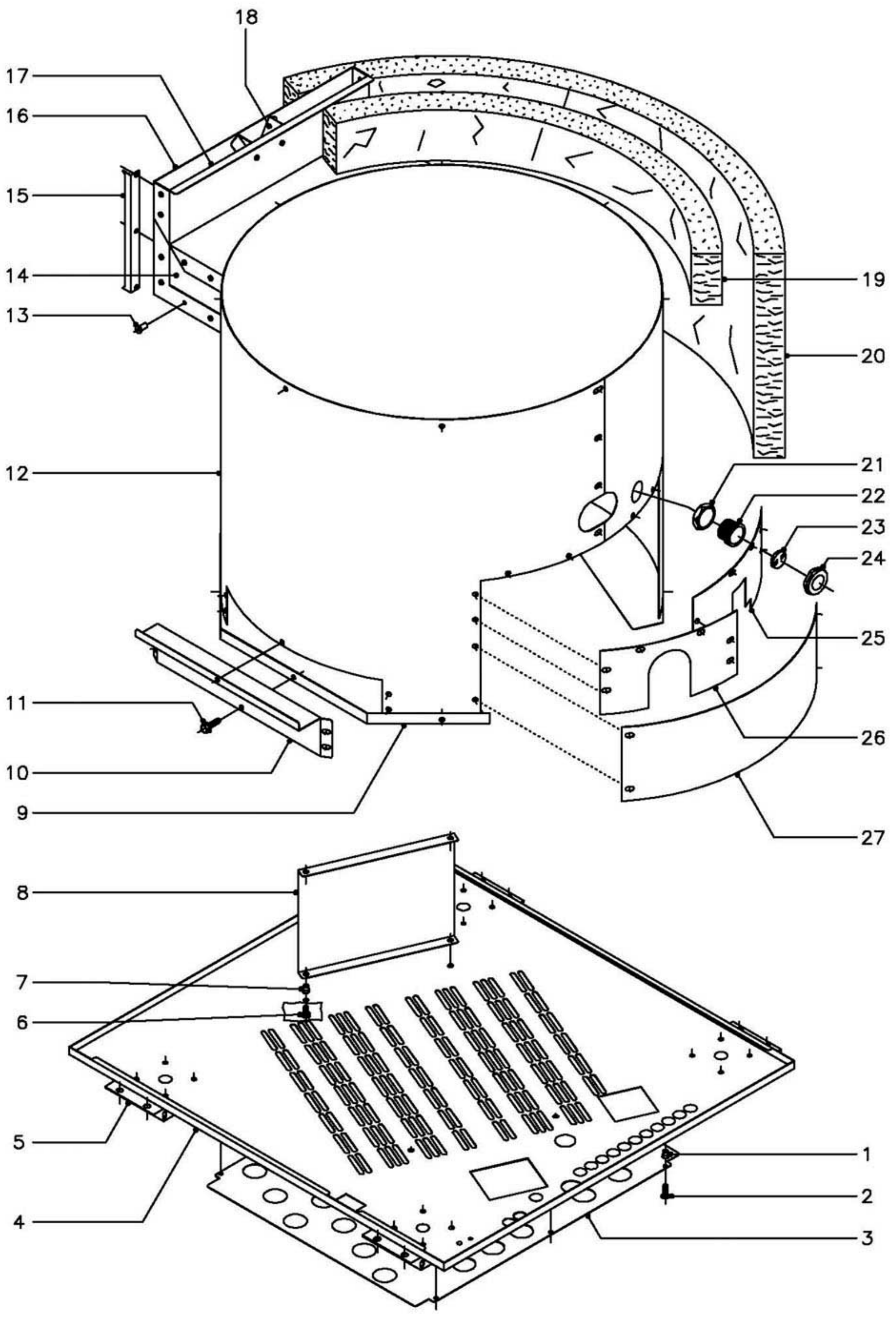

MOD.		MARMITAS		ZONA		PIEZAS INTERIORES						PLANO		C-1051	
ITEM	CODIGO	DENOMINACION	TEXTO	MG9-10	MG9-15	MG9-20	MG9-10 S	MG9-15 S	MG9-20 S					NOTAS	
1	Q221342	Remache exagonal M-5		-	-	6	-	-	-						
2	Q152004	Tornillo aplastado M-5x13		-	-	6	-	-	-						
3	S272610	Proteccion suelo		-	-	1	-	-	-						
4	S272606	Base inferior		1	1	1	-	-	-						
4	S062811	Base inferior		-	-	-	1	-	-						
4	S372814	Base inferior		-	-	-	-	1	1						
5	S032631	Liston soporte patas		2	2	2	-	-	-						
6	Q012031	Tornillo exagonal M-5x10		4	4	4	4	4	4						
7	Q221342	Remache exagonal M-5		4	4	4	4	4	4						
8	S012616	Soporte quemador		2	-	-	-	-	-						
8	S032639	Soporte quemador		-	2	-	-	2	-						
8	S062606	Soporte quemador		-	-	-	2	-	-						
9	S032636	Cierre de envolvente		1	1	-	1	1	-						
9	S042625	Cierre de envolvente		-	-	1	-	-	1						
10	S272609	Cierre lateral envolvente		-	-	2	-	-	2						
11	Q151323	Tornillo broca M-4,8x16		30	30	30	30	30	35						
12	S012615	Envolvente		1	-	-	-	-	-						
12	S032635	Envolvente		-	1	-	-	1	-						
12	S272605	Envolvente		-	-	1	-	-	1						
12	S062605	Envolvente		-	-	-	1	-	-						
13	Q419005	Remache tubular Ø4x8		24	24	24	24	24	24						
14	S032641	Amarre lateral chimenea		2	2	-	2	2	-						
14	S042631	Amarre lateral chimenea		-	-	2	-	-	2						
15	X162657	Distanciador de chimenea		2	2	2	2	2	2						
16	S032644	Posterior de chimenea		1	1	-	1	1	-						
16	S042628	Posterior de chimenea		-	-	1	-	-	1						
17	S032643	Anterior de chimenea		1	1	-	1	1	-						
17	S042629	Anterior de chimenea		-	-	1	-	-	1						
18	S035400	Protector chimenea		1	1	1	1	1	1						

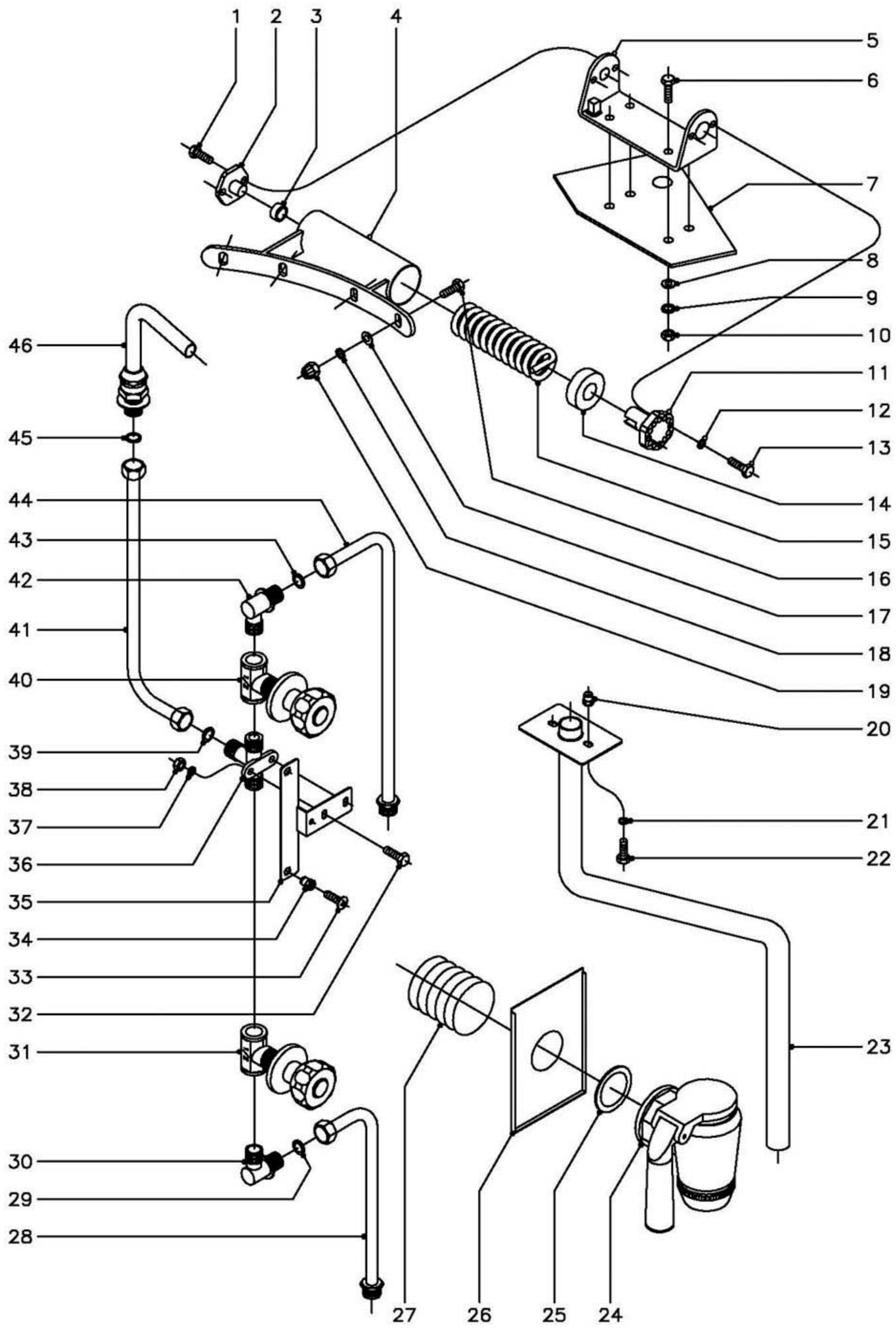

MOD.

MARMITAS

ZONA

TOMAS DE AGUA, DESAGÜES Y BISAGRA TAPA

PLANO

C-1052

ITEM	CODIGO	DENOMINACION	TEXTO	MG9-10	MG9-15	MG9-20	MG9-10 S	MG9-15 S	MG9-20 S				NOTAS
1	Q012041	Tornillo exagonal M-6x10		2	2	2	2	2	2				
2	S116119	Giro de asa		1	1	1	1	1	1				
3	S116126	Cojinete cilindrico		1	1	1	1	1	1				
4	S036143	Bisagra tapa		1	1	1	1	1	1				
4	S036146	Bisagra tapa (Para cuscusera)		1	1	1	-	-	-				
5	S036131	Soporte de bisagra		1	1	1	1	1	1				
6	Q012055	Tornillo exagonal M-8x30		4	4	4	4	4	4				
7	S026102	Refuerzo bisagra		1	1	1	1	1	1				
8	Q232050	Arandela plana A-8		4	4	4	4	4	4				
9	Q262050	Arandela muelle A-8		4	4	4	4	4	4				
10	Q162050	Tuerca exagonal M-8		4	4	4	4	4	4				
11	S116120	Tensor resorte		1	1	1	1	1	1				
12	Q262040	Arandela muelle A-6		2	2	2	2	2	2				
13	Q012042	Tornillo exagonal M-6x15		2	2	2	2	2	2				
14	S116118	Casquillo		1	1	1	1	1	1				
15	S116121	Resorte tapa		1	1	1	1	1	1				
16	Q012053	Tornillo exagonal M-8x20		4	4	4	4	4	4				
17	Q232050	Arandela plana A-8		4	4	4	4	4	4				
18	Q262050	Arandela muelle A-8		4	4	4	4	4	4				
19	Q212051	Tuerca sombrerete M-8		4	4	4	4	4	4				
20	Q221342	Remache exagonal M-5		2	2	2	2	2	2				
21	Q262030	Arandela muelle A-5		2	2	2	2	2	2				
22	Q012032	Tornillo exagonal M-5x15		2	2	2	2	2	2				
23	S036119	Tubo vaciado		1	1	1	-	1	1				
23	S065004	Tubo vaciado		-	-	-	1	-	-				
24	S112150	Grifo de vaciado		1	1	1	1	1	1				
25	S112152	Junta grifo vaciado		1	1	1	1	1	1				
26	S112803	Cubierta de grifo		1	1	1	1	1	1				
27	S112105	Muelle soporte cubierta		1	1	1	1	1	1				

MOD.

MARMITAS

ZONA

TOMAS DE AGUA, DESAGÜES Y BISAGRA TAPA

PLANO

C-1052

ITEM	CODIGO	DENOMINACION	TEXTO	MG9-10	MG9-15	MG9-20	MG9-10 S	MG9-15 S	MG9-20 S				NOTAS
28	S035036	Conducto entrada agua inferior		1	1	1	-	-	-				
28	S065020	Conducto entrada agua inferior		-	-	-	1	-	-				
28	S375007	Conducto entrada agua inferior		-	-	-	-	1	1				
29	Q306024	Arandela junta Ø18xØ12,5x1,5		1	1	1	1	1	1				
30	S115013	Codo		1	1	1	1	1	1				
31	S112151	Llave de paso con mando (fria)		1	1	1	1	1	1				
32	Q012042	Tornillo exagonal M-6x15		2	2	2	2	2	2				
33	Q152004	Tornillo aplastado M-5x13		2	2	2	2	2	2				
34	Q221342	Remache exagonal M-5		2	2	2	2	2	2				
35	S032640	Soporte grifos de agua		1	1	1	1	1	1				
36	S205022	Racord union de grifos		1	1	1	1	1	1				
37	Q262040	Arandela muelle A-6		2	2	2	2	2	2				
38	Q162040	Tuerca exagonal M-6		2	2	2	2	2	2				
39	Q306024	Arandela junta Ø18xØ12,5x1,5		1	1	1	1	1	1				
40	S112154	Llave de paso con mando (calien.)		1	1	1	1	1	1				
41	S035032	Conducto grifos a base		1	1	1	1	1	1				
42	S115013	Codo		1	1	1	1	1	1				
43	Q306024	Arandela junta Ø18xØ12,5x1,5		1	1	1	1	1	1				
44	S035035	Conducto entrada agua superior		1	1	1	-	-	-				
44	S065018	Conducto entrada agua superior		-	-	-	1	-	-				
44	S345010	Conducto entrada agua superior		-	-	-	-	1	1				
45	Q306024	Arandela junta Ø18xØ12,5x1,5		1	1	1	1	1	1				
46	S052100	Tubo de llenado		1	1	1	1	1	1				

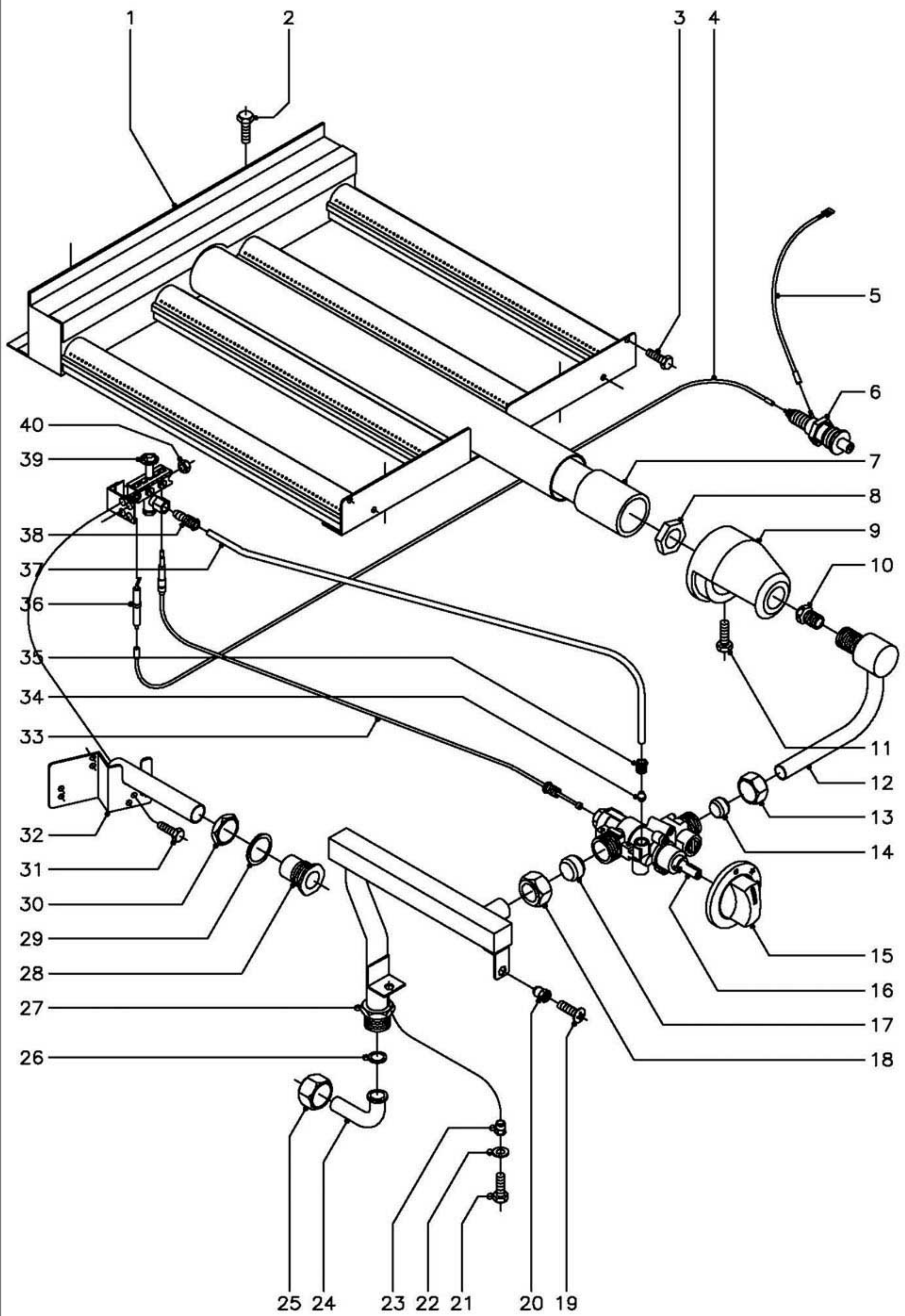

ITEM	CODIGO	DENOMINACION	TEXTO	MG9-10	MG9-15	MG9-20	MG9-10 S	MG9-15 S	MG9-20 S				NOTAS
1	S275705	Quemador		1	1	1	1	1	1				
2	Q012031	Tornillo exagonal M-5x10		4	4	4	4	4	4				
3	Q012031	Tornillo exagonal M-5x10		2	2	2	2	2	2				
4	U323030	Cable bujia a piezoelectrico		1	1	1	1	1	1				
5	U333003	Cable masa a piezoelectrico		1	1	1	1	1	1				
6	S113034	Piezoelectrico		1	1	1	1	1	1				
7	S135733	Venturi		1	1	1	1	1	1				
8	Q221302	Tuerca exagonal 1/2"		1	1	1	1	1	1				
9	0628100	Camara de mezcla		1	1	1	1	1	1				
10	S012400	Tobera Ø2,20 (Butano-Propano)		1	-	-	1	-	-				
10	S032400	Tobera Ø2,45 (Butano-Propano)		-	1	-	-	1	-				
10	S172400	Tobera Ø2,55 (Butano-Propano)		-	-	1	-	-	1				
10	S012401	Tobera Ø3,10 (Gas Natural)		1	-	-	1	-	-				
10	S114401	Tobera Ø3,65 (Gas Natural)		-	1	-	-	1	-				
10	S114400	Tobera Ø3,80 (Gas Natural)		-	-	1	-	-	1				
10	S012402	Tobera Ø5,90 (Gas Villa)		1	-	-	1	-	-				
10	S032401	Tobera Ø6,90 (Gas Villa)		-	1	-	-	1	-				
10	S172402	Tobera Ø7,75 (Gas Villa)		-	-	1	-	-	1				
11	Q012043	Tornillo exagonal M-6x20		1	1	1	1	1	1				
12	S015010	Conduccion a quemador		1	-	-	1	-	-				
12	S035025	Conduccion a quemador		-	1	-	-	1	-				
12	S045025	Conduccion a quemador		-	-	1	-	-	1				
13	S312105	Tuerca fijacion conduc.a quemador		1	1	1	1	1	1				
14	S312106	Bicono Ø16		1	1	1	1	1	1				
15	S312110	Boton de mando Ø10		1	1	1	1	1	1				
16	S312101	Grifo SC. PEL-23S. V (min. Ø1,40)		1	1	1	1	1	1				
17	S312104	Bicono Ø20		1	1	1	1	1	1				
18	S312103	Tuerca fijacion conduc. General		1	1	1	1	1	1				
19	Q152004	Tornillo aplastado M-5x13		1	1	1	1	1	1				

MOD.		MARMITAS		ZONA		PARTE FUNCIONAL GAS						PLANO		C-1053	
ITEM	CODIGO	DENOMINACION	TEXTO	MG9-10	MG9-15	MG9-20	MG9-10 S	MG9-15 S	MG9-20 S					NOTAS	
20	Q221342	Remache exagonal M-5		1	1	1	1	1	1						
21	Q012042	Tornillo exagonal M-6x15		1	1	1	1	1	1						
22	Q302022	Arandela plana Ø16xØ6x1,2		1	1	1	1	1	1						
23	Q221343	Remache exagonal M-6		1	1	1	1	1	1						
24	U565007	Codo entrada gas		1	1	1	-	-	-						
25	U725006	Tuerca 3/4"		1	1	1	-	-	-						
26	Q306052	Arandela junta Ø23,5xØ15,5x3		1	1	1	-	-	-						
27	S035030	Conduccion general		1	1	1	-	-	-						
27	S065016	Conduccion general		-	-	-	1	-	-						
27	S035030	Conduccion general		-	-	-	-	1	1						
28	S112804	Embellecedor tubo de encendido		1	1	1	1	1	1						
29	Q306027	Arandela junta Ø33,8xØ27x1,5		1	1	1	1	1	1						
30	Q221324	Tuerca exagonal 3/4"		1	1	1	1	1	1						
31	Q012031	Tornillo exagonal M-5x10		2	2	2	2	2	2						
32	S045028	Tubo de encendido		1	1	1	1	1	1						
33	U562130	Termopar L=850		1	1	1	1	1	1						
34	X205028	Bicono Ø 6		1	1	1	1	1	1						
35	S312107	Manguito tubo piloto		1	1	1	1	1	1						
36	X012101	Bujia de encendido		1	1	1	1	1	1						
37	S015012	Tubo piloto de 100 l.		1	-	-	1	-	-						
37	S035027	Tubo piloto de 150 l.		-	1	-	-	1	-						
37	S045027	Tubo piloto de 200 l.		-	-	1	-	-	1						
38	U134323	Racord con bicono Ø 6		1	1	1	1	1	1						
39	R202100	Conjunto soporte y piloto		1	1	1	1	1	1						
	U442138	Inyector piloto Ø 0,25 (B.P.y G.V.)		1	1	1	1	1	1					Regular para G.V.	
	U442137	Inyector piloto Ø 0,40 (Gas Natural)		1	1	1	1	1	1						
40	Q162030	Tuerca exagonal M-5		2	2	2	2	2	2						

MOD.

MARMITAS

ZONA

PIEZAS ESPECIFICAS PARA LOS DISTINTOS GASES

PLANO

C-1053

ITEM	CODIGO	DENOMINACION	TEXTO	MG9-10	MG9-15	MG9-20	MG9-10 S	MG9-15 S	MG9-20 S				NOTAS
		<u>BUTANO - PROPANO</u>											
10	S012400	Tobera Ø 2,20		1	-	-	1	-	-				
10	S032400	Tobera Ø 2,45		-	1	-	-	1	-				
10	S172400	Tobera Ø 2,55		-	-	1	-	-	1				
39	U442138	Inyector piloto Ø 0,25		1	1	1	1	1	1				
s/n	U136501	Indicador (Butano - Propano)		1	1	1	1	1	1				
		<u>GAS NATURAL</u>											
10	S012401	Tobera Ø 3,10		1	-	-	1	-	-				
10	S114401	Tobera Ø 3,65		-	1	-	-	1	-				
10	S114400	Tobera Ø 3,80		-	-	1	-	-	1				
39	U442137	Inyector piloto Ø 0,40		1	1	1	1	1	1				
s/n	U134402	Indicador (Gas Natural)		1	1	1	1	1	1				
		<u>GAS VILLA</u>											
10	S012402	Tobera Ø 5,90		1	-	-	1	-	-				
10	S032401	Tobera Ø 6,90		-	1	-	-	1	-				
10	S172402	Tobera Ø 7,75		-	-	1	-	-	1				
39	U442138	Inyector piloto Ø 0,25		1	1	1	1	1	1				Regular para G.V.
s/n	U134310	Indicador (Gas Villa)		1	1	1	1	1	1				

