

Marmitas
Marmites
Boiling Pans
Kochkessel
Pentole

GAMA 900

Modelos:

MG9-10 BM

MG9-15 BM

MG9-10 BM S

MG9-15 BM 316

MG9-15 BM S

Mayo 2006 May

FAGOR 

Fagor Industrial

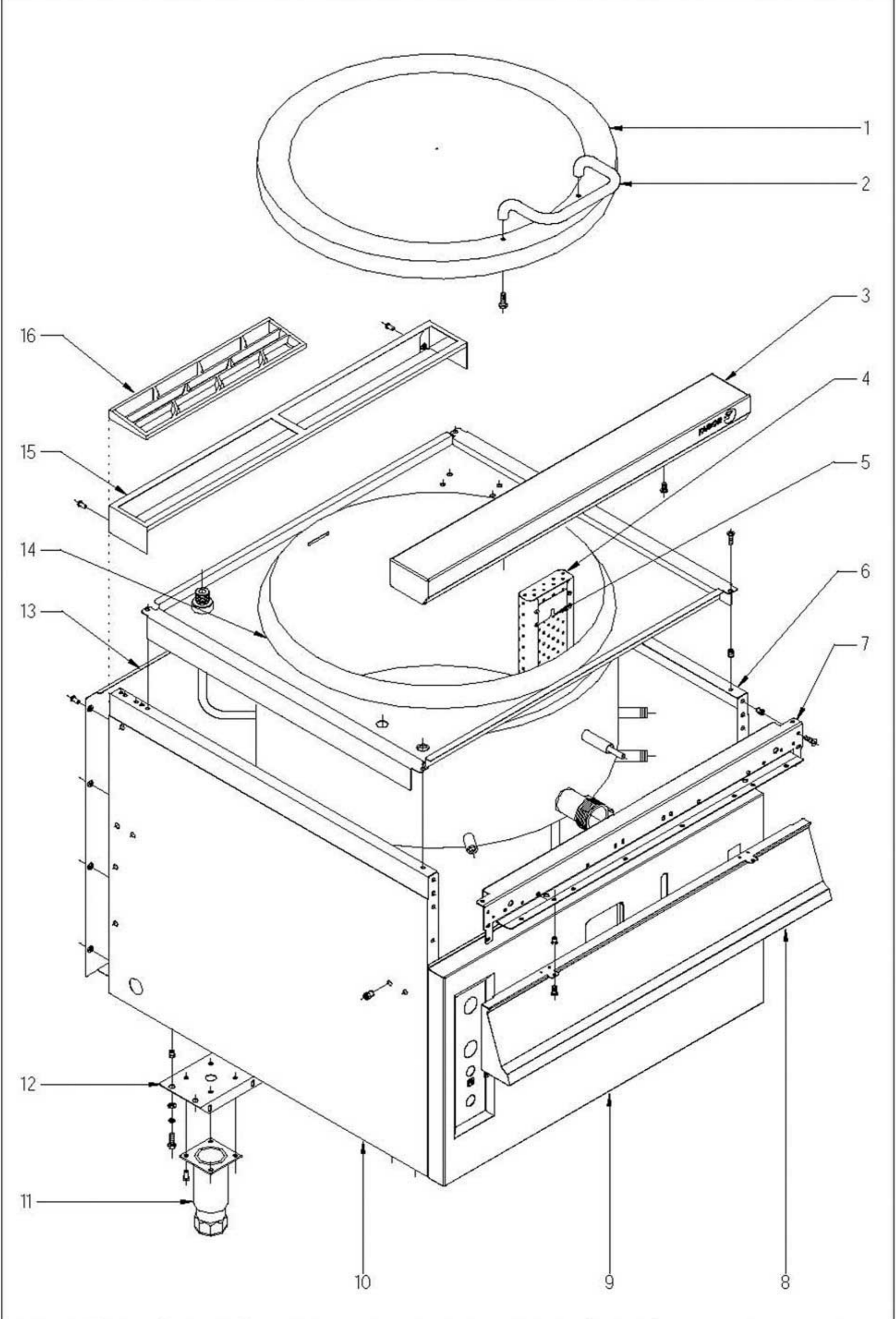

Nplano	Firma	Fecha	Aparato	MUEBLE	Lamina	Fagor Industrial S.Coop. FAGOR
C-1701	<i>[Signature]</i>	2006-05	MARMITA MG9-10BM, MG9-15BM		1	Oñate

MOD.		MARMITAS GAMA 900		ZONA	MUEBLE					PLANO	C-1701
ITEM	CODIGO	DENOMINACION	TEXTO	MG9-10 BM	MG9-15 BM	MG9-10 BM S	MG9-15 BM S	MG9-15 BM 316			NOTAS
1	S036141000	TAPA COMPLETA		1	1	1	1				
1	S096112000	TAPA COMPLETA						1			
	Q152004000	TORNILLO APLAST. M5x13 A304		4	4	4	4	4			
	Q221342000	REMACHE EXAGONAL M5		2	2	2	2	2			
2	S036123000	ASA DE TAPA		1	1	1	1				
2	S096140000	ASA DE TAPA						1			
	Q012053000	TORNILLO EXAGONAL M8x20 A304		2	2	2	2	2			
	Q302027000	ARANDELA 25x8,4x2		2	2	2	2	2			
3	S105401000	ANTERIOR DE MESA 1M		1	1			1			
	Q152004000	TORNILLO APLAST. M5x13 A304		2	2			2			
	Q302022000	ARANDELA 16x6x1,2 A304		2	2			2			
4	S016101000	FILTRO DE CUBA		1	1	1	1				
5	S036117000	SOPORTE FILTRO		2	2	2	2				
	Q412000000	REMACHE TUBULAR 4x8		8	8	8	8				
6	X162811000	PANEL LATERAL DERECHO G9-00		1	1			1			
6	X192805000	PANEL LATERAL DERECH.G9-00S				1					
6	S372812000	PANEL LATERAL DERECH.G9-00S					1				
	Q221343000	REMACHE EXAGONAL M6		4	4			4			
	Q221342000	REMACHE EXAGONAL M5		1	1	1	1	1			
	Q221342000	REMACHE EXAGONAL M5		3	3	3	3	3			
	Q221342000	REMACHE EXAGONAL M5		1	1	1	1	1			
	Q221343000	REMACHE EXAGONAL M6		7	7			7			
	Q221345000	REMACHE EXAGONAL M10				1	1				
	Q162030000	TUERCA EXAGONAL M5				2	2				
7	U022601000	ESCUADRA INTE.AMARRE ANT.1M		1	1	1	1	1			
	Q221342000	REMACHE EXAGONAL M5		3	3	3	3	3			
	Q152004000	TORNILLO APLAST. M5x13 A304		6	6	6	6	6			
	Q221342000	REMACHE EXAGONAL M5		2	2	2	2	2			
8	S222804000	PORTAMANDOS COMPLETO		1	1	1	1	1			
	Q152004000	TORNILLO APLAST. M5x13 A304		2	2	2	2	2			

MOD.		MARMITAS GAMA 900		ZONA	MUEBLE					PLANO	C-1701
ITEM	CODIGO	DENOMINACION	TEXTO	MG9-10 BM	MG9-15 BM	MG9-10 BM S	MG9-15 BM S	MG9-15 BM 316			NOTAS
9	S142801000	PANEL FRONTAL MG9-10 BM		1	-	-	-	-			
9	S222802000	PANEL FRONTAL MG9-15 BM		-	1	-	1	1			
9	S142802000	PANEL FRONTAL MG9-10 BM S		-	-	1	-	-			
	Q012042000	TORNILLO EXAGONAL M6x15		2	2	2	2	2			
	Q302022000	ARANDELA 16x6x1,2 A304		2	2	2	2	2			
10	X162810000	PANEL LATERAL IZDO. G9-00		1	1	-	-	1			
10	X192803000	PANEL LATERAL IZDO. G9-00		-	-	1	-	-			
10	S372810000	PANEL LATERAL IZDO. G9-00		-	-	-	1	-			
	Q221343000	REMACHE EXAGONAL M6		4	4	-	-	4			
	Q221342000	REMACHE EXAGONAL M5		1	1	1	1	1			
	Q221342000	REMACHE EXAGONAL M5		3	3	3	3	3			
	Q221342000	REMACHE EXAGONAL M5		1	1	1	1	1			
	Q221343000	REMACHE EXAGONAL M6		7	7	-	-	7			
	Q221345000	REMACHE EXAGONAL M10		-	-	1	1	-			
	Q162030000	TUERCA EXAGONAL M5		-	-	2	2	-			
11	X260151000	PATA REGULABLE		4	4	-	-	4			
	Q411304000	REMACHE AVIBULB Ø4,8		16	16	-	-	16			
12	S032631000	LISTON SOPORTE PATAS 1M		2	2	-	-	2			
	Q012042000	TORNILLO EXAGONAL M6x15		8	8	-	-	8			
	Q302022000	ARANDELA 16x6x1,2 A304		8	8	-	-	8			
	Q232040000	ARANDELA A6		8	8	-	-	8			
13	U562853000	PANEL POSTERIOR 1M G9-00		1	1	-	-	1			
13	X242817000	PANEL POSTERIOR 1M G9-10 S		-	-	1	-	-			
13	S372816000	PANEL POSTERIOR 1M G9-15 S		-	-	-	1	-			
	Q419005000	REMACHE 4x8 ALMG3 / ALUMINIO		8	8	8	8	8			
14	S146112000	CUBA COMPLETA MG9-10 BM		1	-	1	-	-			
14	S226102000	CUBA COMPLETA MG9-15 BM		-	1	-	1	-			
14	S046165000	CUBA COMPLETA MG9-15 BM		-	-	-	-	1			
15	R205428000	SOPORTE EMBELLECEDOR 1M		1	1	1	1	1			
16	R205425000	EMBELLECEDOR ESMALTE		2	2	2	2	2			

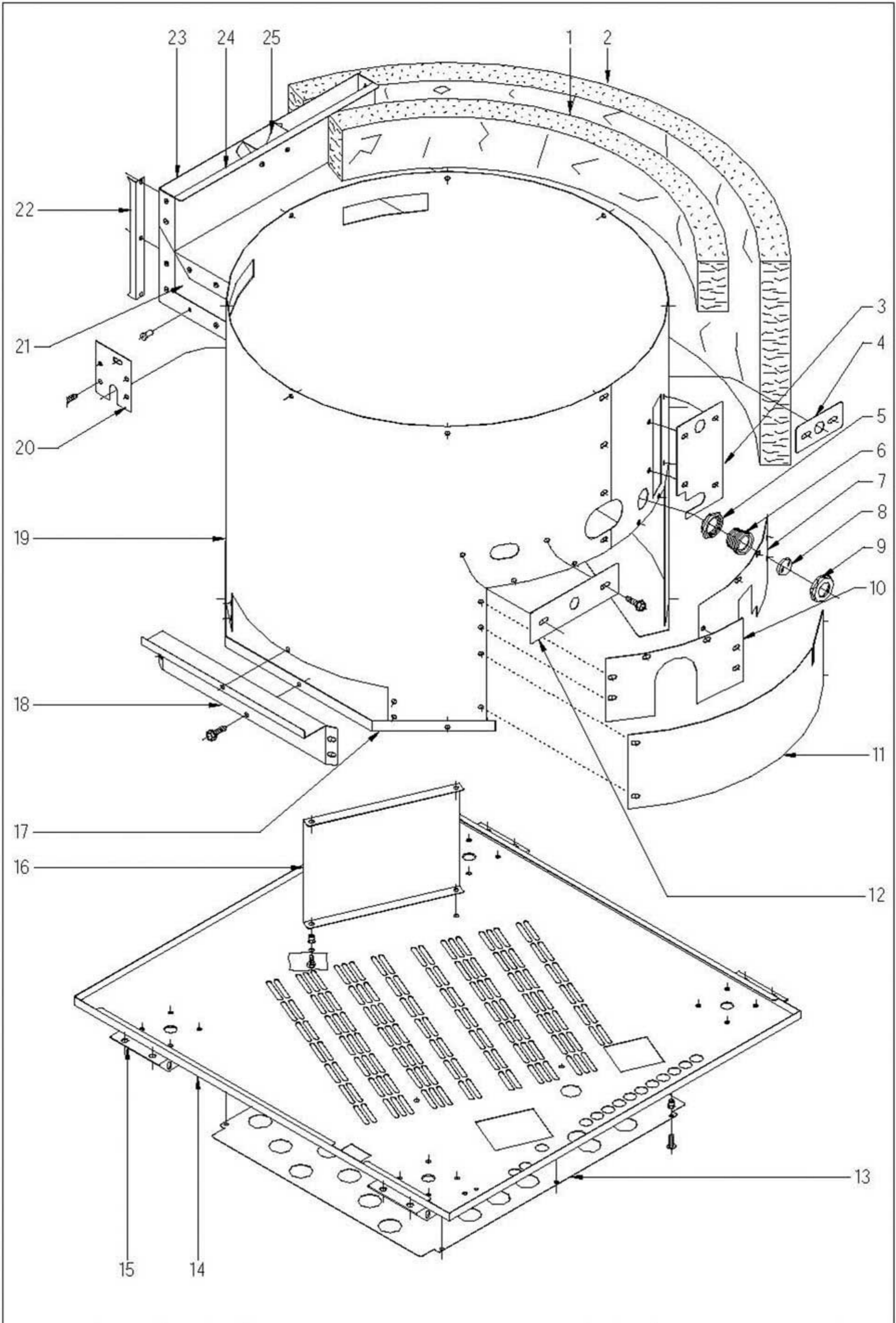

Nplano	Firma	Fecha	Aparato	PIEZAS INTERIORES	Lamina	Fagor Industrial S.Coop. FAGOR
C-1702	<i>[Signature]</i>	2006-05	MARMITA	MG9-10BM, MG9-15BM	2	Ofite

MOD.

MARMITAS GAMA 900

ZONA

PIEZAS INTERIORES

PLANO

C-1702

ITEM	CODIGO	DENOMINACION	TEXTO	MG9-10 BM	MG9-15 BM	MG9-10 BM S	MG9-15 BM S	MG9-15 BM 316				NOTAS
1	S116403000	AISLANTE 1300x100x25		2	2	2	2	2				
2	R092622000	AISLANTE 1370x650x20		2	2	2	2	2				
3	S042653000	TAPA VISUALIZADOR MG9- BM		1	1	1	1	1				
	Q151323000	TORNILLO BROCA 4,8x16		4	4	4	4	4				
4	S142602000	TAPA MANGÜITO MG9-10 BM		1	-	1	-	-				
4	S042652000	TAPA MANGÜITO MG9-15 BM		-	1	-	1	1				
	Q151323000	TORNILLO BROCA 4,8x16		4	4	4	4	4				
5	Q223014000	CONTRATUERCA 1 LATON		1	1	1	1	1				
6	9294500000	PORTAMIRILLA LATON		1	1	1	1	1				
7	S022647000	TAPA INFER. DERECHO MG9-10BM		1	1	1	-	1				
7	S042656000	TAPA INFERIOR DERECHO		-	-	-	1	-				
	Q151323000	TORNILLO BROCA 4,8x16		4	4	4	4	4				
8	9294600000	MIRILLA CRISTAL		1	1	1	1	1				
9	9294400000	TUERCA CIERRE		1	1	1	1	1				
10	S042655000	TAPA INFERIOR IZQUIERDO		1	1	1	1	1				
	Q151323000	TORNILLO BROCA 4,8x16		4	4	4	4	4				
	Q151323000	TORNILLO BROCA 4,8x16		2	2	2	2	2				
11	S022648000	TAPA INFERIOR MG9-10 BM		1	-	-	-	-				
	Q151323000	TORNILLO BROCA 4,8x16		5	-	-	-	-				
12	S042644000	TAPA		1	1	1	1	1				
	Q151323000	TORNILLO BROCA 4,8x16		2	2	2	2	2				
13	S272610000	PROTECCION SUELO		-	1	-	-	1				
	Q221342000	REMACHE EXAGONAL M5		-	6	-	-	6				
	Q152004000	TORNILLO APLAST. M5x13 A304		-	6	-	-	6				

MOD.		MARMITAS GAMA 900		ZONA	PIEZAS INTERIORES					PLANO	C-1702	
ITEM	CODIGO	DENOMINACION	TEXTO	MG9-10 BM	MG9-15 BM	MG9-10 BM S	MG9-15 BM S	MG9-15 BM 316				NOTAS
14	S272606000	BASE INFERIOR		1	1			1				
14	S062811000	BASE INFERIOR MG9-10 BM S				1						
14	S372818000	BASE INFERIOR MG9-15 BM S					1					
	Q221343000	REMACHE EXAGONAL M6		2	2	2	2	2				
	Q162030000	TUERCA EXAGONAL M5				4	4					
	Q221345000	REMACHE EXAGONAL M10				2	2					
	Q151356000	TORNILLO EXAGONAL M10x110				2	2					
	Q232060000	ARANDELA A10				2	2					
15	S032631000	LISTON SOPORTE PATAS 1M		2	2			2				
	Q012042000	TORNILLO EXAGONAL M6x15		8	8			8				
	Q302022000	ARANDELA 16x6x1,2 A304		8	8			8				
	Q232040000	ARANDELA A6		8	8			8				
16	S022616000	SOPORTE QUEMADOR		2								
16	S072605000	SOPORTE QUEMADOR				2						
	Q012031000	TORNILLO EXAGONAL M5x10 A304		4		4						
	Q221342000	REMACHE EXAGONAL M5		4		4						
	Q221342000	REMACHE EXAGONAL M5		4		4						
17	S042651000	CIERRE ENVOLVENTE MG9-10 BM		1	1	1	1	1				
18	S272609000	CIERRE LATERAL ENVOLVENTE		2	2		2	2				
18	S072607000	CIERRE LATERAL ENVOLVENTE				2						
	Q151323000	TORNILLO BROCA 4,8x16		12	12	12	12	12				
19	S142601000	ENVOLVENTE MG9-10 BM		1								
19	S042649000	ENVOLVENTE MG9-15 BM			1		1	1				
19	S142603000	ENVOLVENTE MG9-10 BM S				1						
	Q151323000	TORNILLO BROCA 4,8x16		8	8	8	8	8				
	Q151323000	TORNILLO BROCA 4,8x16		7	7	7	7	7				
	Q151323000	TORNILLO BROCA 4,8x16		4	4	4	4	4				
20	S042654000	TAPA SALIDA VALVULA		1	1	1	1	1				
	Q151323000	TORNILLO BROCA 4,8x16		5	5	5	5	5				

ITEM	CODIGO	DENOMINACION	TEXTO	MG9-10 BM	MG9-15 BM	MG9-10 BM S	MG9-15 BM S	MG9-15 BM 316				NOTAS
21	S042631000	AMARRE CHIMENEA LATERAL		2	2	2	2	2				
	Q419005000	REMACHE 4x8 ALMG3 / ALUMINIO		12	12	12	12	12				
	Q151323000	TORNILLO BROCA 4,8x16		4	4	4	4	4				
22	X162657000	DISTANCIADOR DE CHIMENEA		2	2	2	2	2				
	Q419005000	REMACHE 4x8 ALMG3 / ALUMINIO		4	4	4	4	4				
S/N°	S032645000	AISLANTE CALOR		1	1	1	1	1				
	Q221342000	REMACHE EXAGONAL M5		2	2	2	2	2				
	Q012031000	TORNILLO EXAGONAL M5x10 A304		2	2	2	2	2				
23	S042628000	POSTERIOR DE CHIMENEA		1	1	1	1	1				
24	S042629000	ANTERIOR DE CHIMENEA		1	1	1	1	1				
	Q419005000	REMACHE 4x8 ALMG3 / ALUMINIO		4	4	4	4	4				
25	S035400000	PROTECTOR DE CHIMENEA		1	1	1	1	1				
	Q419005000	REMACHE 4x8 ALMG3 / ALUMINIO		4	4	4	4	4				

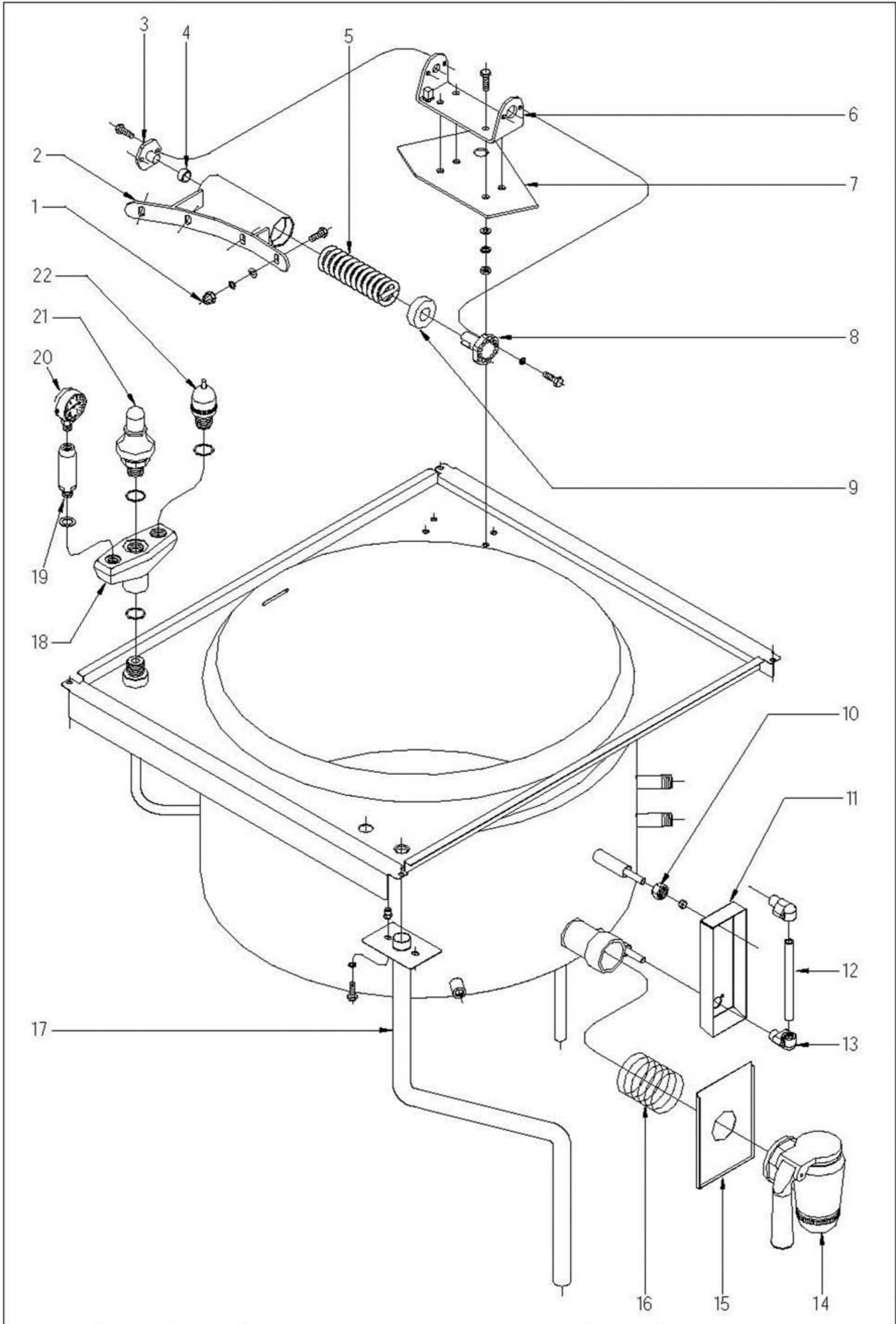

Nplano	Firma	Fecha	Aparato	Lamina	Fagor Industrial S.Coop. FAGOR
C-1703	<i>[Signature]</i>	2006-05	DESAGÜES, VALVULAS, BISAGRAS ETC. MARMITA MG9-10BM, MG9-15BM	3	Oñate

MOD.		MARMITAS GAMA 900		ZONA	DESAGÜES, BISAGRA, VALVULAS Y VISUALIZADOR					PLANO	C-1703	
ITEM	CODIGO	DENOMINACION	TEXTO	MG9-10 BM	MG9-15 BM	MG9-10 BM S	MG9-15 BM S	MG9-15 BM 316				NOTAS
1	Q212051000	TUERCA SOMBRERO M8		4	4	4	4	4				
2	S036143000	BISAGRA COMPLETA		1	1	1	1					
2	S096131000	BISAGRA COMPLETA						1				
	Q012053000	TORNILLO EXAGONAL M8x20 A304		4	4	4	4	4				
	Q232050000	ARANDELA A8		4	4	4	4	4				
	Q262050000	ARANDELA GROW. A8 A304		4	4	4	4	4				
3	S116119000	GIRO DE ASA		1	1	1	1					
3	S096128000	GIRO DE ASA						1				
	Q012041000	TORNILLO EXAGONAL M6x10 A304		2	2	2	2	2				
4	S116126000	COJINETE CILINDRICO		1	1	1	1	1				
5	S116121000	RESORTE TAPA 07199		1	1	1	1					
5	S096127000	RESORTE TAPA 29179						1				
6	S036131000	SOPORTE BISAGRA COMPLETA		1	1	1	1					
6	S096124000	SOPORTE BISAGRA COMPLETA						1				
7	S026102000	REFUERZO BISAGRA MARMITAS		1	1	1	1	1				
	Q012055000	TORNILLO EXAGONAL M8x30 A304		4	4	4	4	4				
	Q162050000	TUERCA EXAGONAL M8x1 INOX		4	4	4	4	4				
	Q232050000	ARANDELA A8		4	4	4	4	4				
	Q262050000	ARANDELA GROW. A8 A304		4	4	4	4	4				
	Q300060000	ARANDELA 18x10x2		4	4	4	4	4				
8	S116120000	TENSOR MUELLE		1	1	1	1					
8	S096129000	TENSOR MUELLE						1				
	Q012042000	TORNILLO EXAGONAL M6x15		2	2	2	2	2				
	Q262040000	ARANDELA GROW. A6 A304		2	2	2	2	2				
9	S116118000	CASQUILLO		1	1	1	1	1				
10	S082101000	TUERCA 3/8		2	2	2	2	2				
	U265008000	BICONO Ø10		2	2	2	2	2				
11	S042647000	PROTECCION VISUALIZADOR		1	1	1	1	1				
	Q032021000	TORNILLO ALOMADO M4x10		4	4	4	4	4				
12	S042102000	TUBO NIVEL SERIGRAFIADO		1	1	1	1	1				
	Q307069000	JUNTA TORICA 17,26x12,36x2,5		2	2	2	2	2				

MOD.		MARMITAS GAMA 900			ZONA		DESAGÜES, BISAGRA, VALVULAS Y VISUALIZADOR				PLANO		C-1703	
ITEM	CODIGO	DENOMINACION	TEXTO	MG9-10 BM	MG9-15 BM	MG9-10 BM S	MG9-15 BM S	MG9-15 BM 316					NOTAS	
13	S042101000	RACORD VISOR NIVEL		2	2	2	2	2						
14	S042107000	GRIFO VACIADO 2"		1	1	1	1	1						
15	S112803000	CUBIERTA GRIFO		1	1	1	1	1						
16	S112105000	MUELLE SOP. CUB. 07003		1	1	1	1							
16	S092100000	MUELLE SOP. CUB. 31061						1						
17	S036119000	TUBO DE VACIADO COMPLETO		1	1		1							
17	S065004000	TUBO DE VACIADO COMPLETO S				1								
17	S095005000	TUBO DE VACIADO PRYCA COMP.						1						
	Q012032000	TORNILLO EXAGONAL M5x15 A304		2	2	2	2	2						
	Q262030000	ARANDELA GROW. A5 A304		2	2	2	2	2						
	Q012063000	TORNILLO EXAGON. M10x20 A304		1	1	1	1	1						
	Q304003000	ARANDELA PLANA 10,5x16x2		1	1	1	1	1						
18	S022100000	SOPORTE 3 SALIDAS 22805062		1	1	1	1	1						
	Q306063000	ARANDELA Ø34x26,7x1,5		1	1	1	1	1						
19	S022102000	PORTAMANOMETRO 2210617		1	1	1	1	1						
	Q306066000	ARANDELA Ø23,9x16,6x3		1	1	1	1	1						
20	9220815000	MANOMETRO 36303601		1	1	1	1	1						
21	S022101000	VALVULA SEGURIDAD 01508004		1	1	1	1	1						
	Q306063000	ARANDELA Ø34x26,7x1,5		1	1	1	1	1						
22	S022103000	VALVULA PRESION 01509004		1	1	1	1	1						
	Q306064000	ARANDELA Ø29,8x24,8x1,5		1	1	1	1	1						

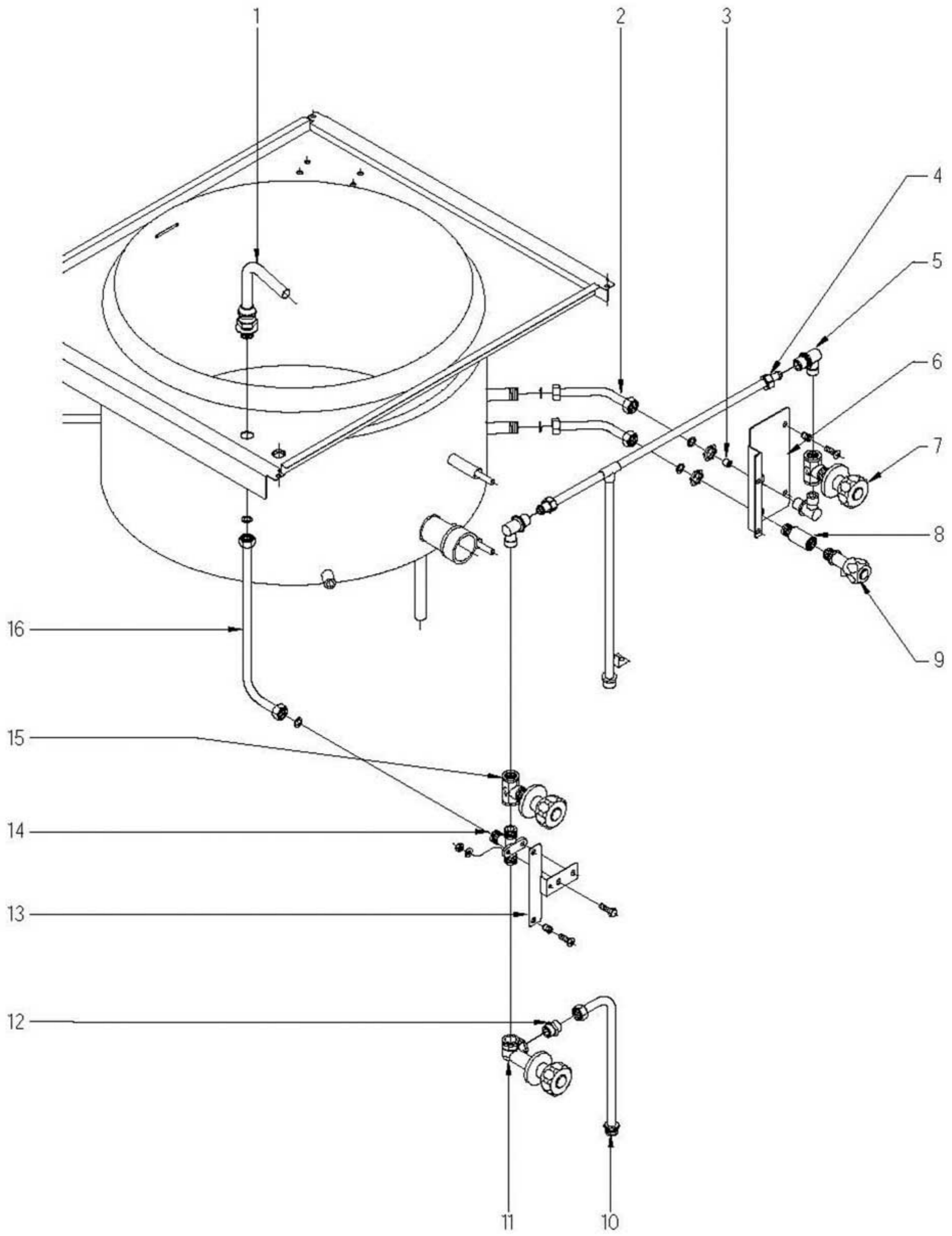

Nplano	Firma	Fecha	Aparato	TOMAS DE AGUA	Lamina	Fagor Industrial S.Coop. FAGOR
C-1704	<i>[Signature]</i>	2006-05	MARMITA MG9-10BM, MG9-15BM		4	Onate

MOD.		MARMITAS GAMA 900		ZONA	TOMAS DE AGUA					PLANO	C-1704	
ITEM	CODIGO	DENOMINACION	TEXTO	MG9-10 BM	MG9-15 BM	MG9-10 BM S	MG9-15 BM S	MG9-15 BM 316				NOTAS
1	S052100000	TUBO DE LLENADO 01102113		1	1	1	1	1				
2	S025006000	CONDUCCION PURGA COMPL. INF.		2	-	2	-	-				
2	S045004000	CONDUCTO A NIVEL COMPLETO		-	2	-	2	2				
	Q306057000	ARANDELA 18x12,5x1,5		4	4	4	4	4				
3	S225012000	REGULADOR DE LLENADO		1	1	1	1	1				
4	S145010000	CONDUCCION SUPERIOR COMPL.		1	1	-	-	1				
4	S145012000	CONDUCCION ENTRADA CAMARA		-	-	1	-	-				
4	S225003000	CONDUCCION ENTRADA CAMARA		-	-	-	1	-				
	Q221343000	REMACHE EXAGONAL M6		1	1	1	1	1				
	Q012042000	TORNILLO EXAGON. M6x15		1	1	1	1	1				
	Q302022000	ARANDELA 16x6x1,2 A304		1	1	1	1	1				
5	S115013000	CODO LATON		3	3	3	3	3				
6	S092601000	SOP. GRIFO LLENADO - VACIADO		1	1	1	1	1				
	Q152004000	TORNILLO APLAST. M5x13 A304		2	2	2	2	2				
	Q221342000	REMACHE EXAGONAL M5		2	2	2	2	2				
7	S102111000	CUER.LLAVE PASO AT.CUADRADO		1	1	1	1	1				
	S012102000	EMBELLECEDOR		1	1	1	1	1				
	S102110000	MANILLA PLASTICO AGUA CALIEN.		1	1	1	1	1				
8	S045006000	CASQUILLO GRIFO NIVEL		1	1	1	1	1				
9	S102124000	GRIFO DE NIVEL C/MANILLA NEG.		1	1	1	1	1				
10	S105020000	CONDUCCION ENTRADA INFERIOR		1	1	-	-	1				
10	S145015000	CONDUCCION INFERIOR COMPL.		-	-	1	-	-				
10	S225017000	CONDUCCION INFERIOR COMPL.		-	-	-	1	-				
	Q221343000	REMACHE EXAGONAL M6		1	1	1	1	1				
	Q012042000	TORNILLO EXAGON. M6x15		1	1	1	1	1				
	Q302022000	ARANDELA 16x6x1,2 A304		1	1	1	1	1				
	Q306057000	ARANDELA 18x12,5x1,5		3	3	3	3	3				
11	S102113000	CUER.LLAVE PASO 90°AT.CUADR.		1	1	1	1	1				
	S012102000	EMBELLECEDOR		1	1	1	1	1				
	S102109000	MANILLA PLASTICO AGUA FRIA		1	1	1	1	1				

ITEM	CODIGO	DENOMINACION	TEXTO	MG9-10 BM	MG9-15 BM	MG9-10 BM S	MG9-15 BM S	MG9-15 BM 316				NOTAS
12	S205023000	MANGUITO DOBLE 1/2		1	1	1	1	1				
	Q221302000	TUERCA EXAGONAL 1/2G		1	1	1	1	1				
13	S162614000	SOPORTE GRIFOS DE AGUA		1	1	1	1	1				
	Q221342000	REMACHE EXAGONAL M5		2	2	2	2	2				
	Q152004000	TORNILLO APLAST. M5x13 A304		2	2	2	2	2				
14	S205022000	RACORD UNION GRIFOS		1	1	1	1	1				
	Q012042000	TORNILLO EXAGON. M6x15		2	2	2	2	2				
	Q162040000	TUERCA EXAGONAL M6		2	2	2	2	2				
15	S102111000	CUER.LLAVE PASO AT.CUADRADO		1	1	1	1	1				
	S012102000	EMBELLECEDOR		1	1	1	1	1				
	S102110000	MANILLA PLASTICO AGUA CALIEN.		1	1	1	1	1				
16	S185004000	CONDUCTO TUBO DE LLENADO		1	1	1	1	1				
	Q306057000	ARANDELA Ø18x12,5x1,5		2	2	2	2	2				

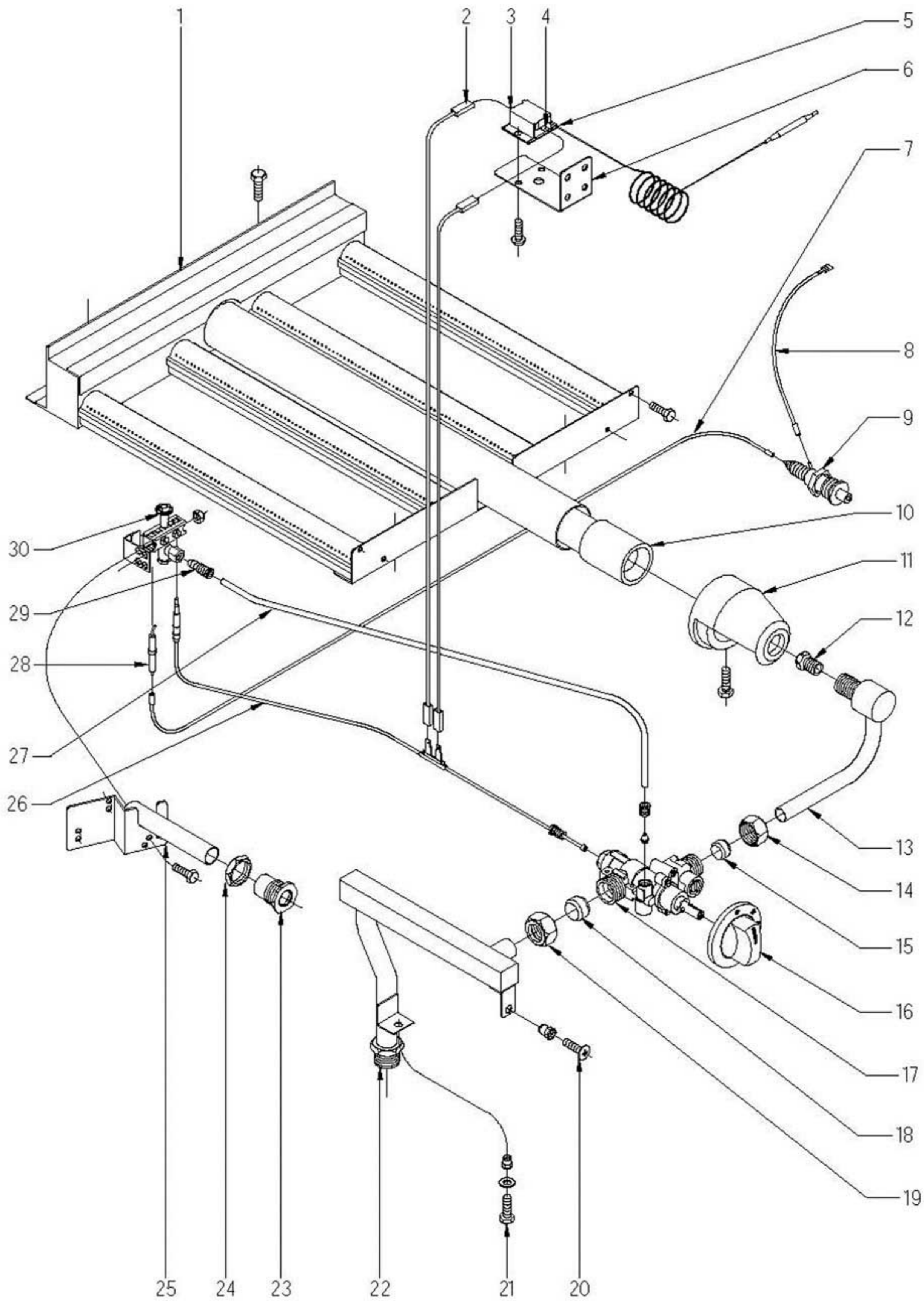

Nplano	Firma	Fecha	Aparato	PARTE FUNCIONAL GAS	Lamina	Fagor Industrial S.Coop. FAGOR
C-1705	<i>[Signature]</i>	2006-05	MARMITA MG9-10BM, MG9-15BM		5	Oñate

MOD.

MARMITAS GAMA 900

ZONA

PARTE FUNCIONAL GAS

PLANO

C-1705

ITEM	CODIGO	DENOMINACION	TEXTO	MG9-10 BM	MG9-15 BM	MG9-10 BM S	MG9-15 BM S	MG9-15 BM 316				NOTAS
1	S275705000	QUEMADOR COMP. MARMITAS		1	1	1	1	1				
	Q012031000	TORNILLO EXAGONAL M5x10 A304		4	4	4	4	4				
2	S223002000	CABLEADO LIMITADOR		1	1	1	1	1				
3	X353007000	SOPORTE TERMOSTATO SEGUR.		1	1	1	1	1				
	Q221341000	REMACHE EXAGONAL M4		2	2	2	2	2				
	Q012021000	TORNILLO EXAGONAL M4x10 A304		2	2	2	2	2				
4	X033001000	TERMOSTATO DE SEGURIDAD		1	1	1	1	1				
5	X353015000	PLACA AISLANTE		1	1	1	1	1				
6	S042648000	SOPORTE LIMITADOR		1	1	1	1	1				
	Q221342000	REMACHE EXAGONAL M5		2	2	2	2	2				
	Q152004000	TORNILLO APLAST. M5x13 A304		2	2	2	2	2				
7	U323030000	CABLE BUJIA		1	1	1	1	1				
8	U333003000	CABLE MASA ENCENDEDOR		1	1	1	1	1				
	Q523000000	TERMINAL LENGÜETA 6,35 (SIMP.)		1	1	1	1	1				
	Q151301000	PHILIPS 8x5/8		1	1	1	1	1				
9	S113034000	PIEZO ELECTRICO		1	1	1	1	1				
10	S135733000	VENTURI MECANIZADO		1	1	1	1	1				
11	O628100000	CAMARA DE MEZCLA		1	1	1	1	1				
	Q012043000	TORNILLO EXAGON. M6x20 A304		1	1	1	1	1				
12	S012400000	TOBERA Ø 2,20 BUT-PROPANO		1		1						
12	S032400000	TOBERA Ø 2,45 BUT-PROPANO			1		1	1				
12	S012401000	TOBERA Ø 3,10 GAS NATURAL		1		1						
12	S114401000	TOBERA Ø 3,65 GAS NATURAL			1		1	1				
12	S012402000	TOBERA Ø 5,90 GAS VILLA		1		1						
12	S032401000	TOBERA Ø 6,90 GAS VILLA			1		1	1				
13	S025010000	CONDUCCION A QUEMADOR COM.		1		1						
13	S045025000	CONDUCCION A QUEMADOR COM.			1		1	1				
	Q221302000	TUERCA EXAGONAL 1/2G		1	1	1	1	1				
14	S312105000	TUERCA FIJAC.COND.QUEMADOR		1	1	1	1	1				
15	S312106000	BICONO Ø16		1	1	1	1	1				
16	S102103000	BOTON DE MANDO COM.MARMITA		1	1	1	1	1				

MOD.		MARMITAS GAMA 900		ZONA	PARTE FUNCIONAL GAS					PLANO	C-1705	
ITEM	CODIGO	DENOMINACION	TEXTO	MG9-10 BM	MG9-15 BM	MG9-10 BM S	MG9-15 BM S	MG9-15 BM 316				NOTAS
17	S312101000	GRIFO SC. PEL-23S.V D.1,4		1	1	1	1	1				
18	S312104000	BICONO Ø20		1	1	1	1	1				
19	S312103000	TUERCA FIJACC. COND. GENERAL		1	1	1	1	1				
20	Q152004000	TORNILLO APLAST. M5x13 A304		1	1	1	1	1				
	Q221342000	REMACHE EXAGONAL M5		1	1	1	1	1				
21	Q012042000	TORNILLO EXAGONAL M6x15		1	1	1	1	1				
	Q302022000	ARANDELA 16x6x1,2 A304		1	1	1	1	1				
	Q221343000	REMACHE EXAGONAL M6		1	1	1	1	1				
22	S105018000	CONDUCCION GRAL.COMPLETA		1	1			1				
22	S105024000	CONDUCCION GR.COMP.MG9-10S				1						
22	S225002000	CONDUCCION GR.COMP.MG9-15S					1					
23	S105002000	EMBELLECEDOR TUBO ENCENDI.		1	1	1	1	1				
24	Q221324000	TUERCA 3/4 GAS		1	1	1	1	1				
25	S042658000	TUBO ENCENDIDO COMPLETO		1	1	1	1	1				
	Q012031000	TORNILLO EXAGONAL M5x10 A304		2	2	2	2	2				
26	S042106000	TERMOPAR MARMITA BAÑO MARIA		1	1	1	1	1				
27	S015012000	TUBO PILOTO MARMITA 100L		1		1						
27	S045031000	TUBO PILOTO MARMITA 150L			1		1	1				
	X205028000	BICONO Ø 6		1	1	1	1	1				
	S312107000	MANGUITO TUBO PILOTO		1	1	1	1	1				
28	X012101000	BUJIA 915.037		1	1	1	1	1				
29	U134323000	RACORD BICONO Ø 6 958.031		1	1	1	1	1				
30	R202100000	CONJUNTO SOPORTE PILOTO		1	1	1	1	1				
	U442138000	INYECTOR Ø 0,25 (BUTANO-PROP)		1	1	1	1	1				
	U442137000	INYECTOR Ø 0,4 (GAS NATURAL)		1	1	1	1	1				
	U442138000	INYECTOR Ø 0,25 (GAS VILLA)		1	1	1	1	1				REGULAR
	Q012041000	TORNILLO EXAGON. M6x10 A304		2	2	2	2	2				
	Q162040000	TUERCA EXAGONAL M6		2	2	2	2	2				

MOD.

MARMITAS GAMA 900

ZONA

VARIOS

PLANO

ITEM	CODIGO	DENOMINACION	TEXTO	MG9-10 BM	MG9-15 BM	MG9-10 BM S	MG9-15 BM S	MG9-15 BM 316				NOTAS
	S206501000	FOLLETO DE INSTRUCCIONES		1	1	1	1	1				

MOD.

MARMITAS GAMA 900

ZONA

PIEZAS ESPECIFICAS PARA LOS DISTINTOS
GASES

PLANO

ITEM	CODIGO	DENOMINACION	TEXTO	MG9-10 BM	MG9-15 BM	MG9-10 BM S	MG9-15 BM S	MG9-15 BM 316				NOTAS
		<u>BUTANO - PROPANO</u>										
12	S012400000	TOBERA Ø 2,20		1	—	1	—	—				
12	S032400000	TOBERA Ø 2,45		—	1	—	1	1				
30	U442138000	INYECTOR Ø 0,25		1	1	1	1	1				
S/N	U136501000	INDICADOR BUTANO - PROPANO		1	1	1	1	1				
		<u>GAS NATURAL</u>										
12	S012401000	TOBERA Ø 3,10		1	—	1	—	—				
12	S114401000	TOBERA Ø 3,65		—	1	—	1	1				
30	U442137000	INYECTOR PILOTO Ø 0,4		1	1	1	1	1				
S/N	U134402000	INDICADOR GAS NATURAL		1	1	1	1	1				
		<u>GAS VILLA</u>										
12	S012402000	TOBERA Ø 5,90		1	—	1	—	—				
12	S032401000	TOBERA Ø 6,90		—	1	—	1	1				
30	U442138000	INYECTOR PILOTO Ø 0,25		1	1	1	1	1				REGULAR
S/N	U134310000	INDICADOR GAS VILLA		1	1	1	1	1				