

Baño María
Bain Marie
Bain Marie
Bain Marie
Bagnomaria

GAMA 700

Modelos:

BMG-710

BME-705

BME-710

Octubre 2003 October

FAGOR



Fagor Industrial

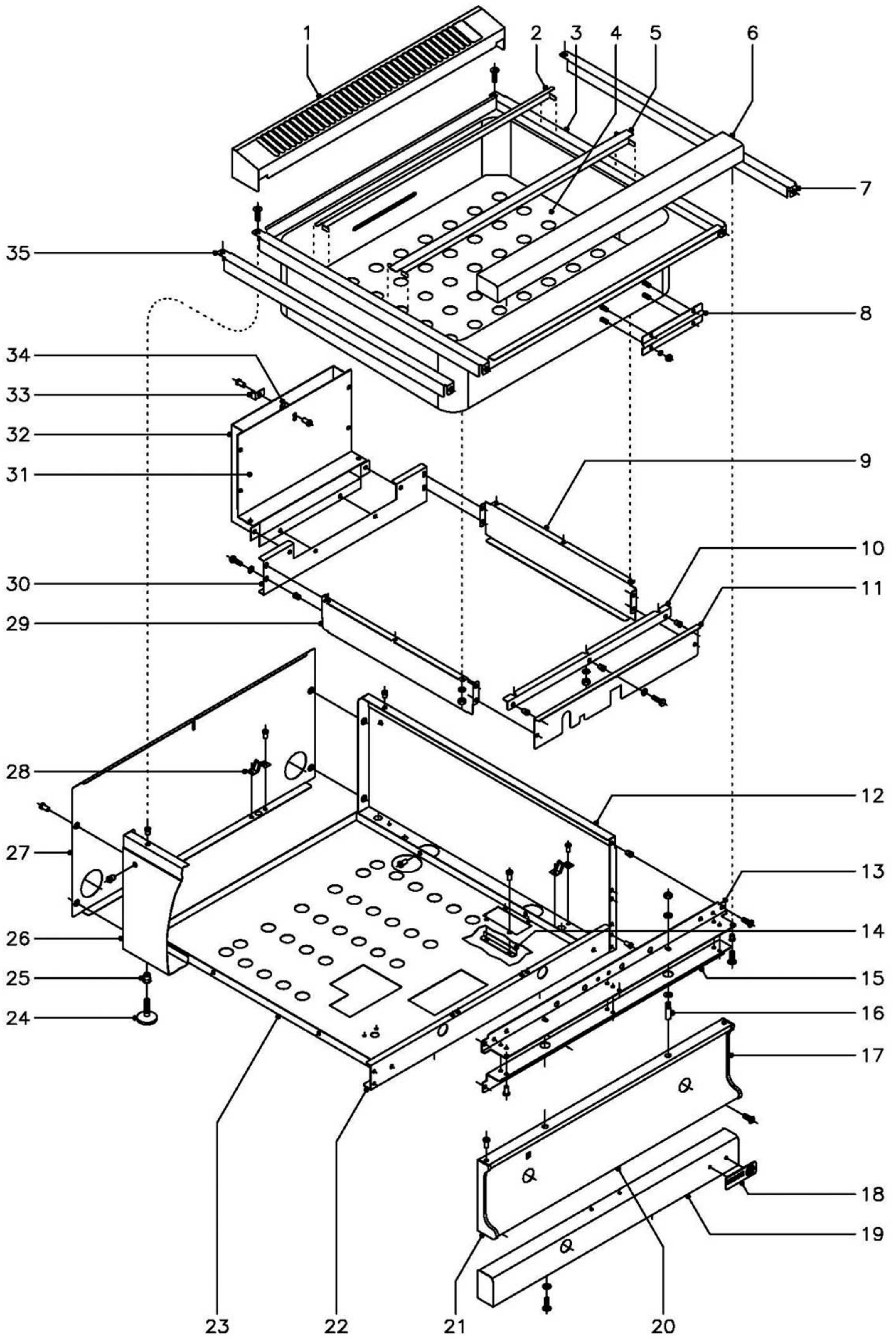

N plano C-1432	Firma 	Fecha 10-2003	Aparato MUEBLE BAÑOS MARIA BM-700	Lamina 1	Fagor Industrial S.Coop. FAGOR Oñate
-------------------	--	------------------	---	-------------	--

MOD.		BAÑO MARIA		ZONA	MUEBLE					PLANO	C-1432
ITEM	CODIGO	DENOMINACION	TEXTO	BME-705	BME-710	BMG-710					NOTAS
1	H325401	Embellecedor posterior 705		1	-	-					
1	H315401	Embellecedor posterior 710		-	1	1					
2	H326107	Separador cubetas posterior 705		1	-	-					
2	H316111	Separador cubetas posterior 710		-	1	1					
3	H326104	Cuba E-705		1	-	-					
	Q232030	Arandela plana A-5		6	-	-					Amarre cuba a panel lateral
	Q162030	Tuerca exagonal M-5		6	-	-					Amarre cuba a panel lateral
3	H336103	Cuba E-710		-	1	-					
3	H316106	Cuba G-710		-	-	1					
	Q152004	Tornillo aplastado M-5x13		-	4	4					
	Q221342	Remache exagonal M-5		-	4	4					
4	H326106	Panel separador 705		1	-	-					
4	H316110	Panel separador 710		-	1	1					
5	R966104	Separador de cubetas 705		3	-	-					
5	R986105	Separador de cubetas 710		-	3	3					
6	X315400	Anterior de mesa 705		1	-	-					
6	U745407	Anterior de mesa 710		-	1	1					
	Q152004	Tornillo aplastado M-5x13		2	3	3					
	Q221342	Remache exagonal M-5		2	3	3					
7	H326110	Liston lateral derecho E-705		1	-	-					
	Q152004	Tornillo aplastado M-5x13		2	-	-					
	Q221342	Remache exagonal M-5		2	-	-					
8	H316112	Proteccion bulbo termostato		1	1	1					
	Q232030	Arandela plana A-5		4	4	4					
	Q162030	Tuerca exagonal M-5		4	4	4					
9	H312603	Lateral caja de combustion		-	-	1					
	Q232030	Arandela plana A-5		-	-	3					
	Q162030	Tuerca exagonal M-5		-	-	3					

MOD.		BAÑO MARIA		ZONA	MUEBLE						PLANO	C-1432
ITEM	CODIGO	DENOMINACION	TEXTO	BME-705	BME-710	BMG-710						NOTAS
10	H312602	Escuadra amarre frente		-	-	1						
	Q232030	Arandela plana A-5		-	-	3						
	Q162030	Tuerca exagonal M-5		-	-	3						
11	H312609	Frente caja de combustion		-	-	1						
	Q221342	Remache exagonal M-5		-	-	5						
	Q232030	Arandela plana A-5		-	-	5						
	Q012031	Tornillo exagonal M-5x10		-	-	5						
12	H322802	Panel lateral derecho 705		1	-	-						
12	U732802	Panel lateral derecho 710		-	1	1						
13	X312600	Escuadra amarre mesa 705		1	-	-						
13	U742607	Escuadra amarre mesa 710		-	1	1						
14	H312610	Proteccion llave desague		2	2	2						
	Q419005	Remache tubular Ø4x8		4	4	4						
15	X312630	Refuerzo amarre mesa 705		1	-	-						
15	U742620	Refuerzo amarre mesa 710		-	1	1						
	Q152004	Tornillo aplastado M-5x13		4	4	4						
	Q221342	Remache exagonal M-5		4	4	4						
	Q419005	Remache tubular Ø 4x8		4	6	6						
16	Q151336	Tornillo soporte guia		2	2	2						
	Q302022	Arandela plana Ø16xØ6x1,2		4	4	4						
	Q162040	Tuerca exagonal M-6		2	2	2						
17	U452804	Cantonera derecha portamandos		1	1	1						
	Q419005	Remache tubular Ø 4x8		2	2	2						
18	U262806	Escudo FAGOR		1	1	1						
	Q221023	Clips sujecion escudo		2	2	2						
19	R962800	Zocalo anterior E-705		1	-	-						
19	R972800	Zocalo anterior E-710		-	1	-						
19	R982800	Zocalo anterior G-710		-	-	1						
	Q012031	Tornillo exagonal M-5x10		2	2	2						

MOD.		BAÑO MARIA		ZONA	MUEBLE						PLANO	C-1432
ITEM	CODIGO	DENOMINACION	TEXTO	BME-705	BME-710	BMG-710						NOTAS
	Q302022	Arandela plana Ø16xØ6x1,2		2	2	2						
20	R962801	Panel portamandos E-705		1	-	-						
20	R972801	Panel portamandos E-710		-	1	-						
20	R982801	Panel portamandos G-710		-	-	1						
	Q152004	Tornillo aplastado M-5x13		2	2	2						
21	U452805	Cantonera izquierda portamandos		1	1	1						
	Q419005	Remache tubular Ø 4x8		2	2	2						
22	U722603	Escuadra anterior base bandejas		1	-	-						
22	R982600	Tirante inferior anterior		-	1	1						
	Q419005	Remache tubular Ø 4x8		4	4	4						
23	H322601	Base inferior E-705		1	-	-						
23	H332601	Base inferior E-710		-	1	-						
23	H312601	Base inferior G-710		-	-	1						
	Q419005	Remache tubular Ø 4x8		4	4	4						
24	Z200105	Pata regulable		4	4	4						
25	Q221345	Remache exagonal M-10		4	4	4						
26	H322801	Panel lateral izquierdo 705		1	-	-						
26	U732801	Panel lateral izquierdo 710		-	1	1						
27	R962802	Panel posterior 705		1	-	-						
27	R982802	Panel posterior 710		-	1	1						
	Q419005	Remache tubular Ø 4x8		4	4	4						
28	X010503	Muelle enganche piton		3	4	4						
	Q419007	Remache tubular Ø 3,2x6		6	8	8						
29	H312603	Lateral caja de combustion		-	-	1						
	Q232030	Arandela plana A-5		-	-	3						
	Q162030	Tuerca exagonal M-5		-	-	3						
30	H312604	Posterior de caja combustion		-	-	1						
	Q221342	Remache exagonal M-5		-	-	4						
	Q232030	Arandela plana A-5		-	-	4						

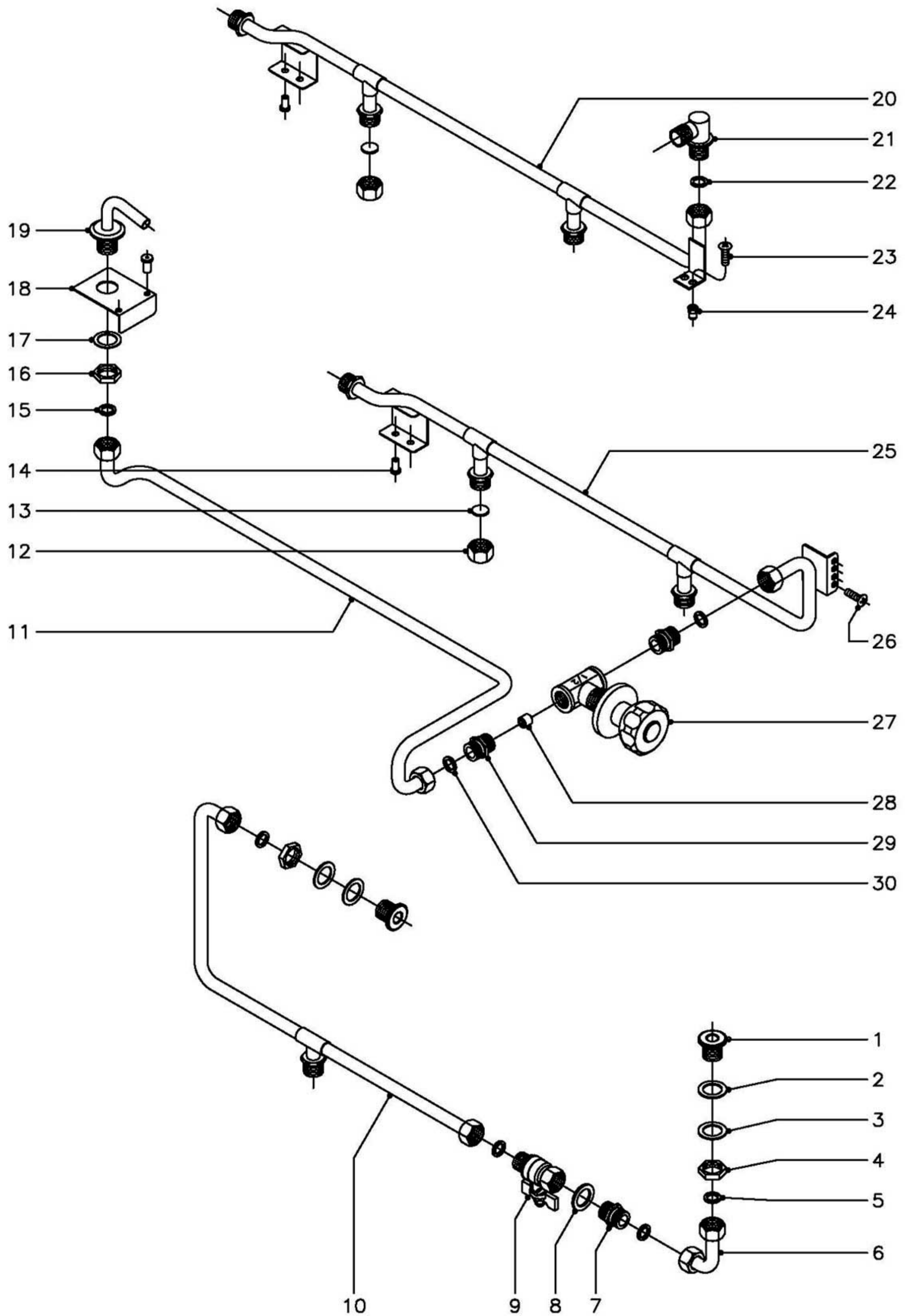

N plano
C-1433

Firma
[Signature]

Fecha
10-2003

Aparato
TOMA DE AGUA Y DESAGUE
BAÑOS MARIA BM-700

Lamina
2

Fagor Industrial S.Coop. **FAGOR**
Oñate

MOD.

BAÑO MARIA

ZONA

TOMA DE AGUA Y DESAGÜE

PLANO

C-1433

ITEM	CODIGO	DENOMINACION	TEXTO	BME-705	BME-710	BMG-710								NOTAS
1	H316113	Casquillo nivel		2	2	2								
2	Q307032	Arandela junta goma Ø32xØ21x1		2	2	2								
3	Q306038	Arandela junta Ø 31xØ 21x1,5		2	2	2								
4	Q221302	Tuerca exagonal 1/2"		2	2	2								
5	Q306024	Arandela junta Ø 18xØ 12,5x1,5		4	4	4								
6	H315013	Salida de desague		1	1	1								
7	S205023	Manguito doble 1/2"		1	1	1								
8	Q306038	Arandela junta Ø 31xØ 21x1,5		1	1	1								
9	H312101	Valvula esfera 1/2" desague		1	1	1								
10	H315015	Conduccion desague		1	1	1								
11	H325002	Conduccion a tubo llenado 705		1	-	-								
11	H315002	Conduccion a tubo llenado 710		-	1	1								
12	R205062	Tuerca ciega 1/2"		2	2	2								
13	Q306053	Arandela tapon Ø18,5x3		2	2	2								
14	Q419005	Remache tubular Ø4x8		2	2	2								
15	Q306024	Arandela junta Ø 18xØ 12,5x1,5		1	1	1								
16	Q221302	Tuerca exagonal 1/2"		1	1	1								
17	Q306038	Arandela junta Ø 31xØ 21x1,5		1	1	1								
18	H312605	Soporte tubo de llenado		1	1	1								
	Q411304	Remache avibulb Ø4,8		2	2	2								
19	H316108	Tubo de llenado		1	1	1								
20	R965003	Conduccion entrada de agua		1	-	-								
21	S115013	Codo a 90° 1/2"		1	-	-								
22	Q306024	Arandela junta Ø18xØ12,5x1,5		1	-	-								
23	Q152004	Tornillo aplastado M-5x13		2	-	-								
24	Q221342	Remache exagonal M-5		2	-	-								
25	R985026	Conduccion entrada de agua		-	1	1								
26	Q152004	Tornillo aplastado M-5x13		-	2	2								
27	S112151	Llave de paso con mando		1	1	1								

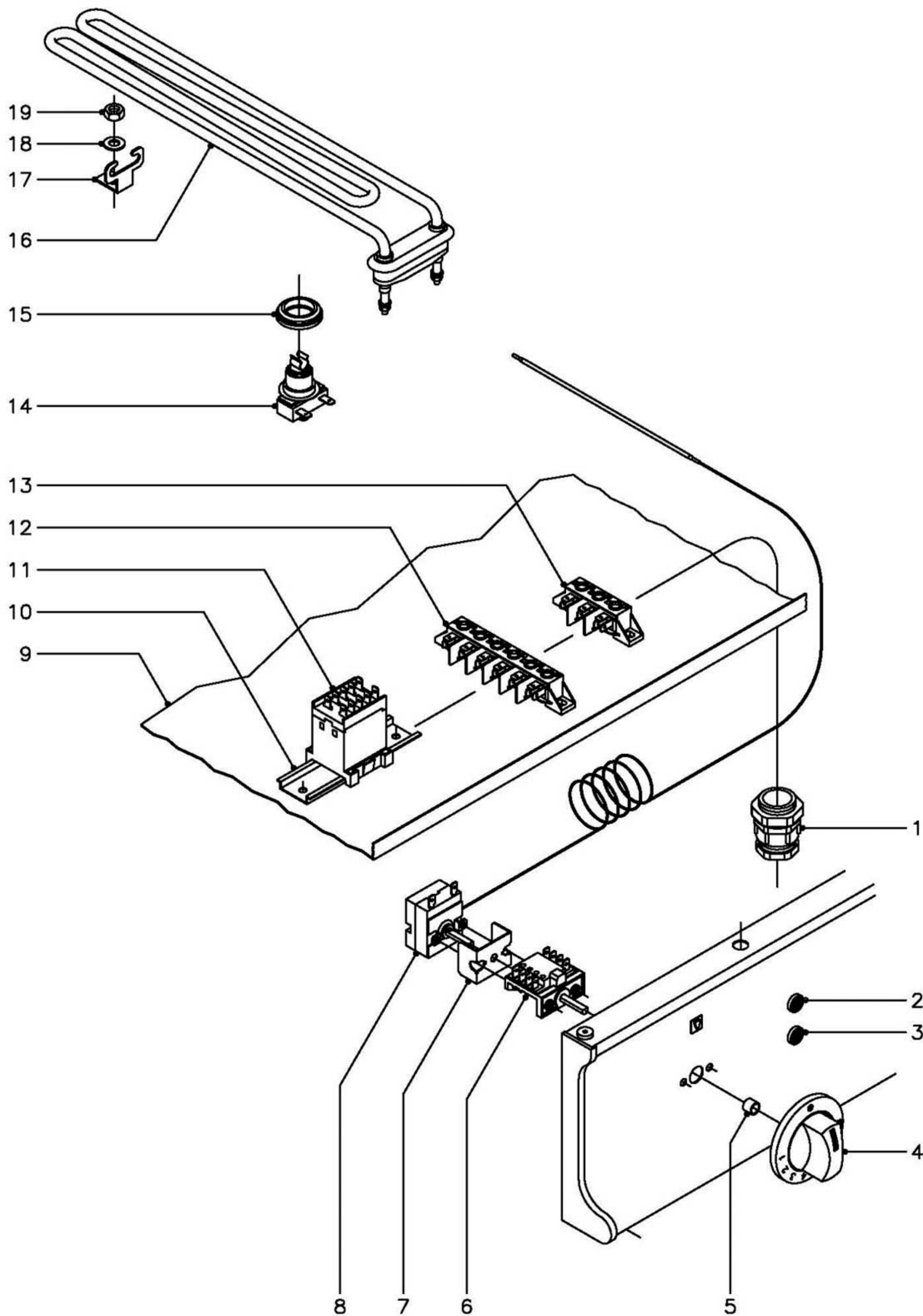

N plano	Firma	Fecha	Aparato	PARTE FUNCIONAL ELECTRICA	Lamina	Fagor Industrial S.Coop. FAGOR
C-1434		10-2003	BAÑO MARIA	BME-705, BME-710	3	Oñate

ITEM	CODIGO	DENOMINACION	TEXTO	BME-705	BME-710									NOTAS
1	R013022	Prensaestopas		1	1									
2	R693055	Piloto verde		1	1									
3	R693056	Piloto ambar		1	1									
4	R212101	Boton de mando Ø 6		1	1									
5	Q281000	Anillo de compresion para mando		1	1									
6	X163007	Conmutador acople termostato		1	1									
	Q151320	Tornillo alomado M-4x6		2	2									
7	X313001	'U" soporte termostato		1	1									
8	Z203014	Termostato 30 - 90°C.		1	1									
9	H322601	Base inferior E-705		1	-									
9	H332601	Base inferior E-710		-	1									
10	R663055	Guia contactor L=120		-	1									
	Q419005	Remache tubular Ø 4x8		-	2									
11	Z213007	Contacto 230 V., 50 - 60 Hz.		-	1									
12	R253044	Regleta auxiliar		-	1									
	Q152004	Tornillo aplastado M-5x13		-	2									
	Q221342	Remache exagonal M-5		-	2									
13	U183046	Regleta auxiliar		1	-									
	Q152004	Tornillo aplastado M-5x13		2	-									
	Q221342	Remache exagonal M-5		2	-									
14	R213004	Termostato rearme manual NC115		1	1									
15	N503017	Soporte termostato		1	1									
16	R223005	Resistencia (2.000 W., 230V.)		1	3									
17	Z603602	Soporte resistencia		1	3									
18	Q232030	Arandela plana A-5		1	3									
19	Q162030	Tuerca exagonal M-5		1	3									

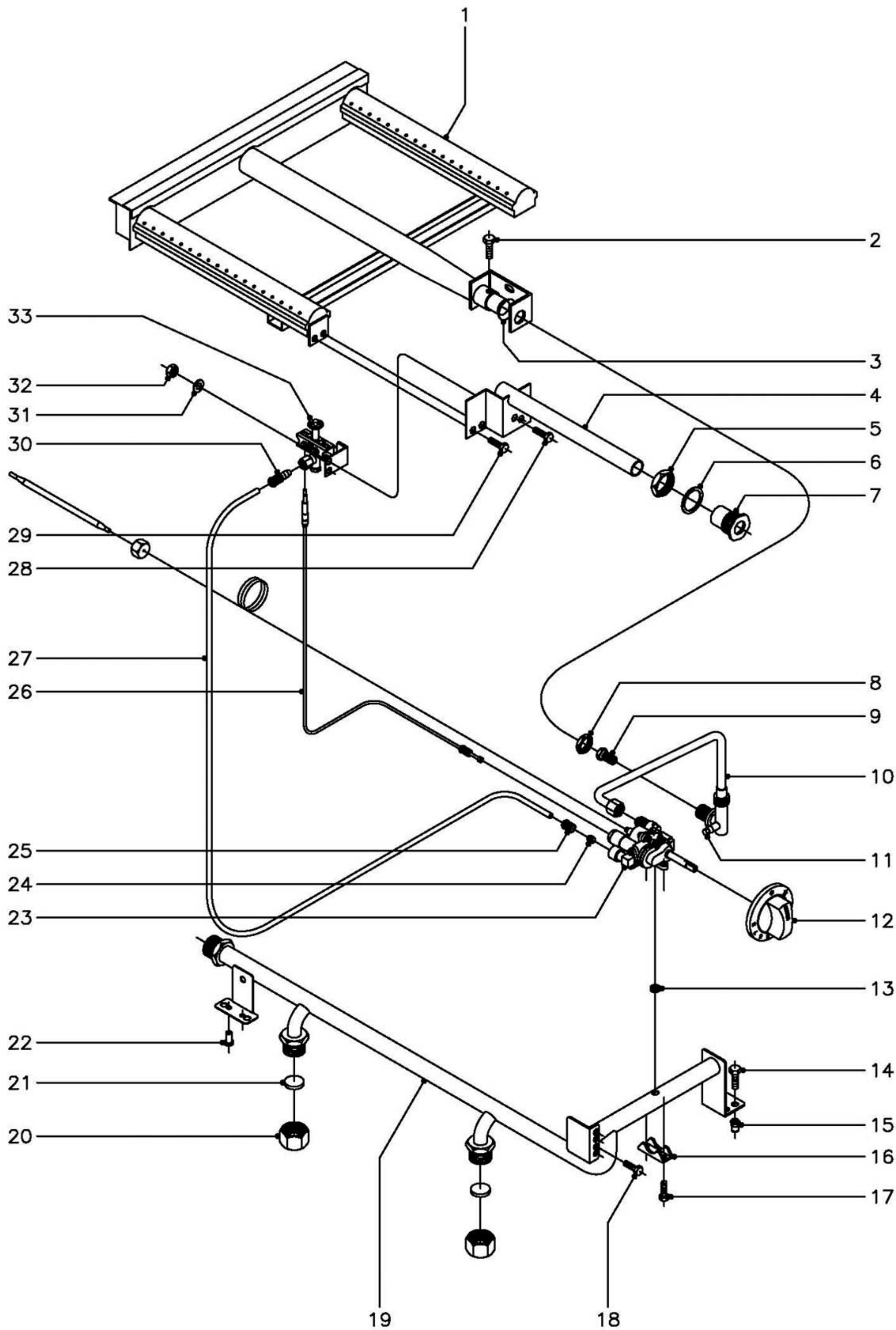

MOD.		BAÑO MARIA		ZONA	PARTE FUNCIONAL GAS							PLANO	C-1435
ITEM	CODIGO	DENOMINACION	TEXTO	BMG-710								NOTAS	
1	R405700	Quemador		1									
2	Q012031	Tornillo exagonal M-5x10		1									
3	U325707	Regulador de aire		1									
4	R985008	Conjunto de encendido		1									
5	Q221324	Tuerca exagonal 3/4"		1									
6	Q306027	Arandela junta Ø33,8xØ27x1,5		1									
7	R982606	Embellecedor tubo de encendido		1									
8	Q223019	Tuerca exagonal 3/8"		1									
9	R422400	Tobera Ø 1,25 (B.P.)		1									
9	9429500	Tobera Ø 1,90 (G.N.)		1									
9	U192402	Tobera Ø 4,90 (G.V.)		1									
10	H315009	Conduccion a quemador		1									
11	Q153002	Tornillo toma presion		1									
12	H352102	Boton de mando Ø 8		1									
13	Q307034	Junta de estanqueidad		1									
14	Q012031	Tornillo exagonal M-5x10		2									
15	Q221342	Remache exagonal M-5		2									
16	Z982018	Brida amarre termostato 1/2"		1									
17	Q151317	Tornillo exagonal M-5x22		2									
18	Q012031	Tornillo exagonal M-5x10		2									
19	H315006	Conduccion general		1									
20	U635008	Tuerca ciega 3/4"		2									
21	Q306051	Arandela tapon Ø23,5x4		2									
22	Q419005	Remache tubular Ø 4x8		2									
23	H352101	Termostato MTZ-22300		1									
24	X205028	Bicono Ø 6		1									
25	U195009	Manguito empalme		1									
26	U222130	Termopar L=600		1									
27	H315010	Conduccion a piloto		1									

MOD.

BAÑO MARIA

ZONA

PIEZAS ESPECIFICAS PARA LOS DISTINTOS GASES

PLANO

C-1435

ITEM	CODIGO	DENOMINACION	TEXTO	BMG-710																NOTAS
		<u>BUTANO - PROPANO</u>																		
9	R422400	Tobera quemador Ø 1,25		1																
33	U442138	Inyector piloto Ø 0,25		1																
s/n	U136501	Indicador (Butano - Propano)		1																
		<u>GAS NATURAL</u>																		
9	9429500	Tobera quemador Ø 1,90		1																
33	U442137	Inyector piloto Ø 0,40		1																
s/n	U134402	Indicador (Gas Natural)		1																
		<u>GAS VILLA</u>																		
9	U192402	Tobera Ø 4,90 (G.V.)		1																
33	U442138	Inyector piloto Ø 0,25		1																Regular para G.V.
s/n	U134310	Indicador (Gas Villa)		1																

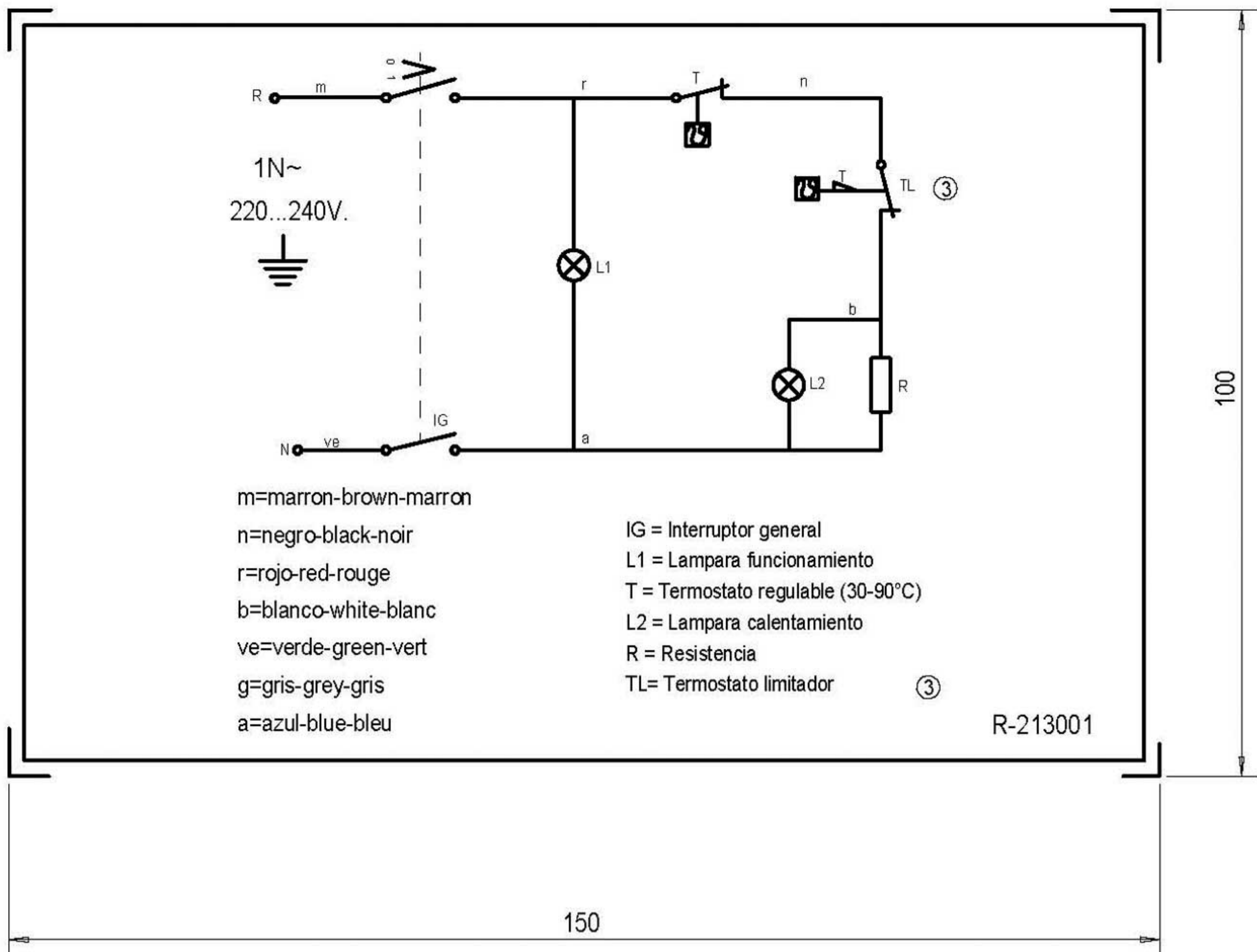

NOTA: - LAS INSCRIPCIONES RESISTIRAN SIN MODIFICACION APRECIABLE, EL FROTAMIENTO DURANTE 15 SEG. DE UN ALGODON EMPAPADO EN GASOLINA.

Plastico blanco alto brillo

BME-705		R213001		
Esquema teorico adhesivo BME 905		R213001		
Nº	Pieza	Material	Nº Clasificacion	Acabado
Nº	Modificacion	Propuesta de	Fecha	Tolerancias generales
①	Cambiar indicacion de tension	oregi	21-5-96	$\leq 5\pm$ $5-25\pm$ $25-50\pm$ $50-100\pm$ $> 100\pm$ $\infty\pm$
2	Modific.general(pasar a fabri.interior)	Plazaola	22-4-97	
3	Introducir limitador	ION	99-7-12	
Firma		Fecha		Mecanizado superficial
Dibujado		93-9-10		
Proyectado		FAGOR 		
Comprobado		Fagor Industrial,Koop.Elk, Mugatua		
Escala		BAÑO-MARIA		Plano numero
				HB-14461 -3
		Plano hau ez daiteke erabil ez berrizta gure baimenitz gabe		Sustituye al Nº
				Sustituido por

BME9-10 BME-710

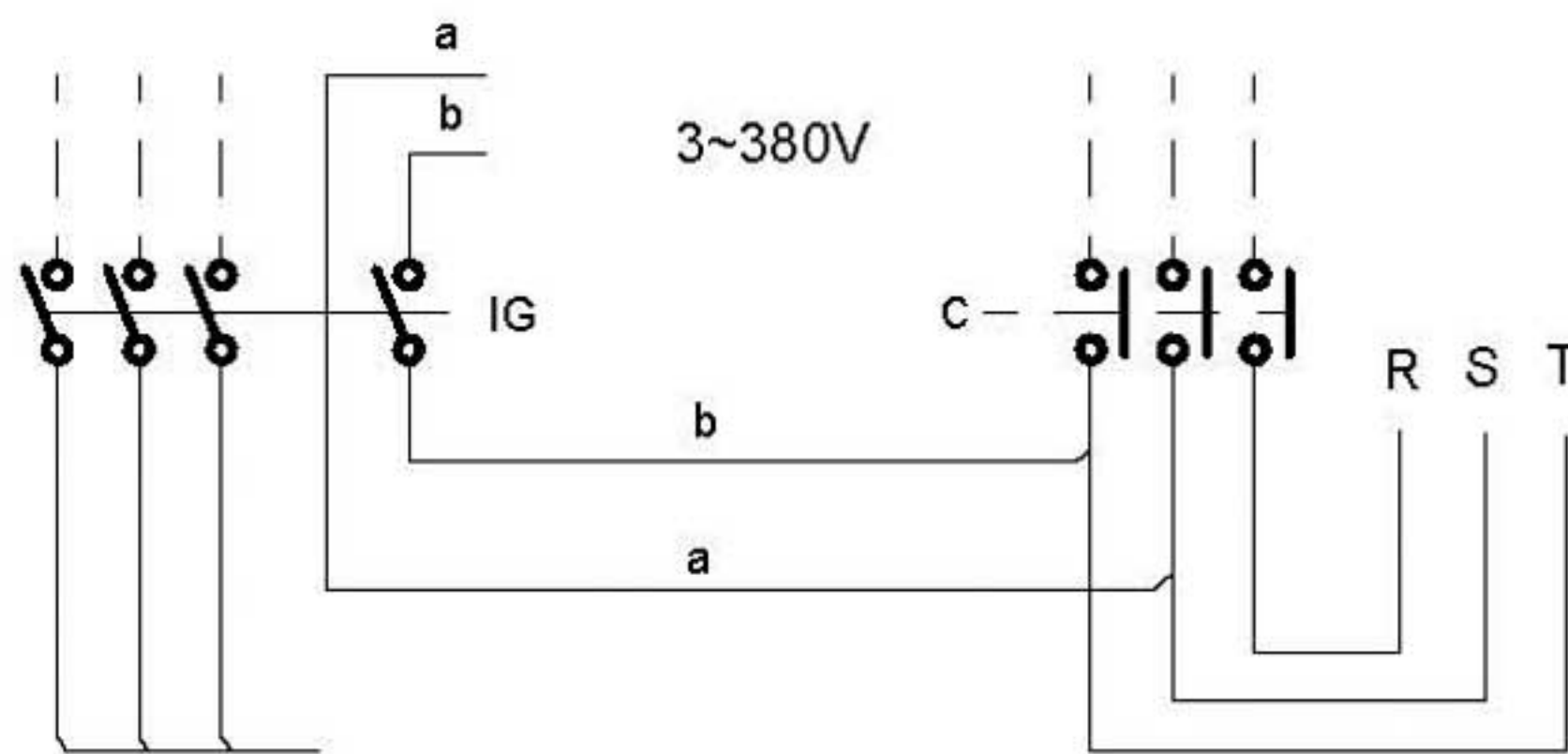
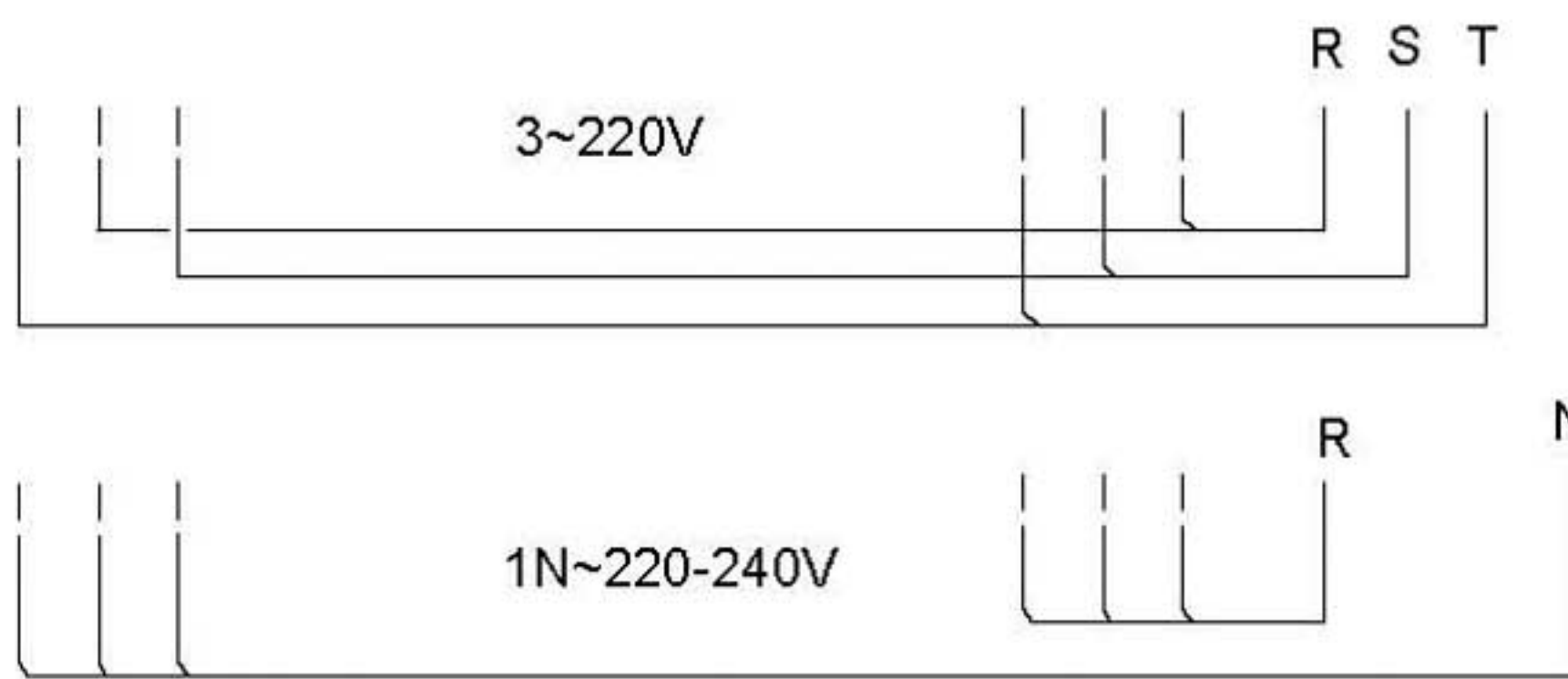
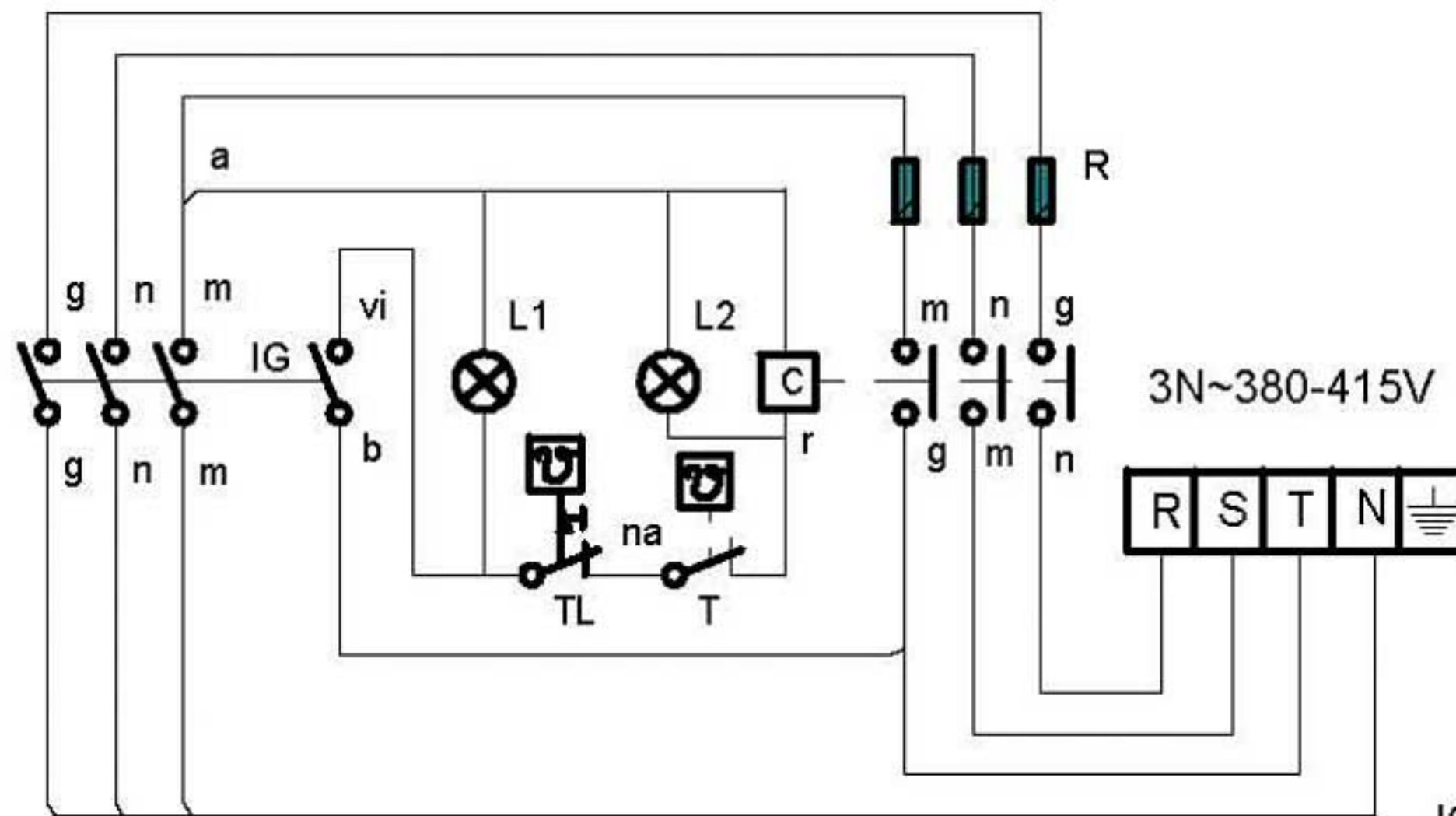

- IG: Interruptor general
- L1: Lámpara funcionamiento
- T: Termostato regulable (50-90°C)
- L2: Lámpara calentamiento
- C: Contactor de calentamiento
- R: Resistencias
- TL: Termostato limitador

- r = rojo-red-rouge
- m = marron-brown-marron
- g = gris-grey-gris
- n = negro-black-noir
- a = azul-blue-bleu
- b = blanco-white-blanc
- am/ve = amarillo/verde
yellow/green
jaune/vert

Esquema teorico adhesivo				R-223007							
Nº	Pieza	Cant.	Material	Nº Clasificacion	Acabado						
Nº	Modificacion		Propuesta de	Fecha	Tolerancias generales						
					<table border="0"> <tr> <td><5±</td> <td>50-100±</td> </tr> <tr> <td>5-25±</td> <td>> 100±</td> </tr> <tr> <td>25-50±</td> <td>∞±</td> </tr> </table>	<5±	50-100±	5-25±	> 100±	25-50±	∞±
<5±	50-100±										
5-25±	> 100±										
25-50±	∞±										
Dibujado	Firma	Fecha	 Fagor Industrial, Koop. Elk, Mugatua		Mecanizado superficial						
Proyectado	ION	99-7-12									
Comprobado											
Escala	BAÑO-MARIA			Plano numero	HB-71386						
	Plano hau ez daiteke erabil ez berrizta gure baimenitz gabe			Sustituye al Nº							
				Sustituido por							

1 Modulo BME-910 BME-710

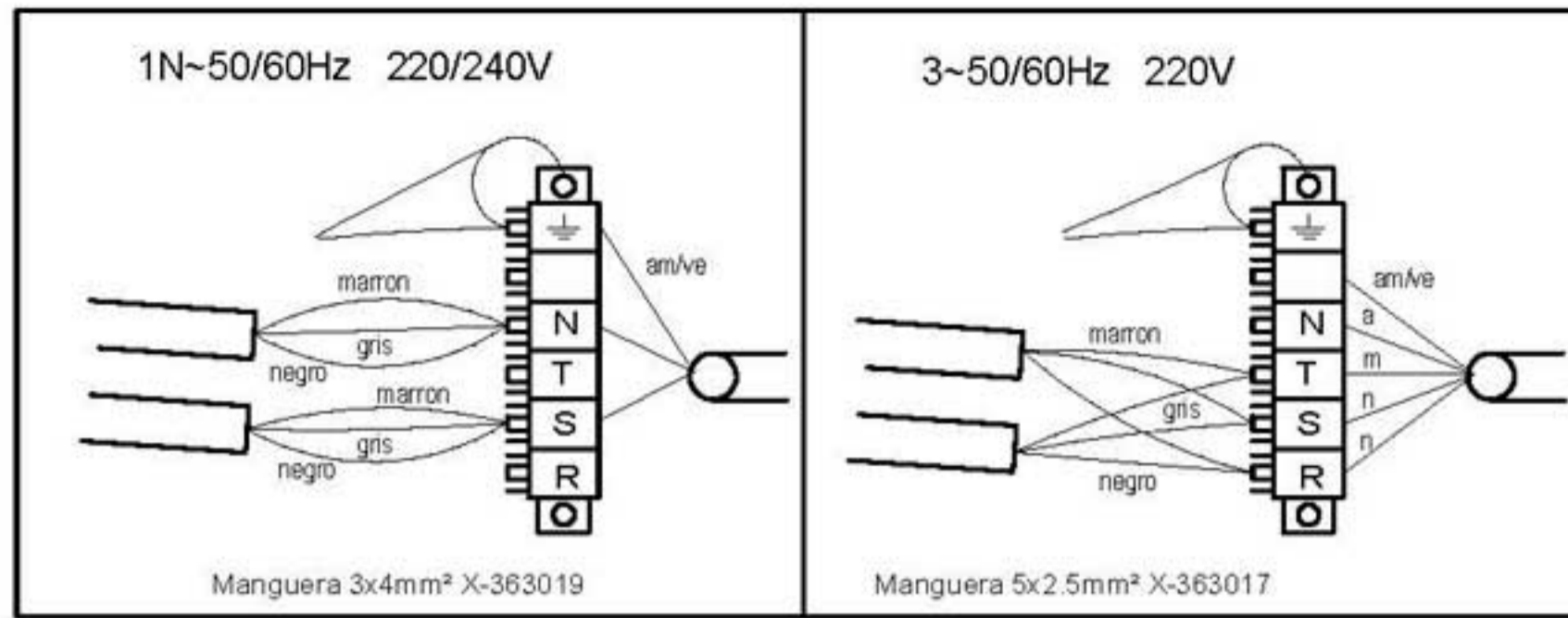

Manguera 3x4mm² X-363019

Manguera 5x2.5mm² X-363017

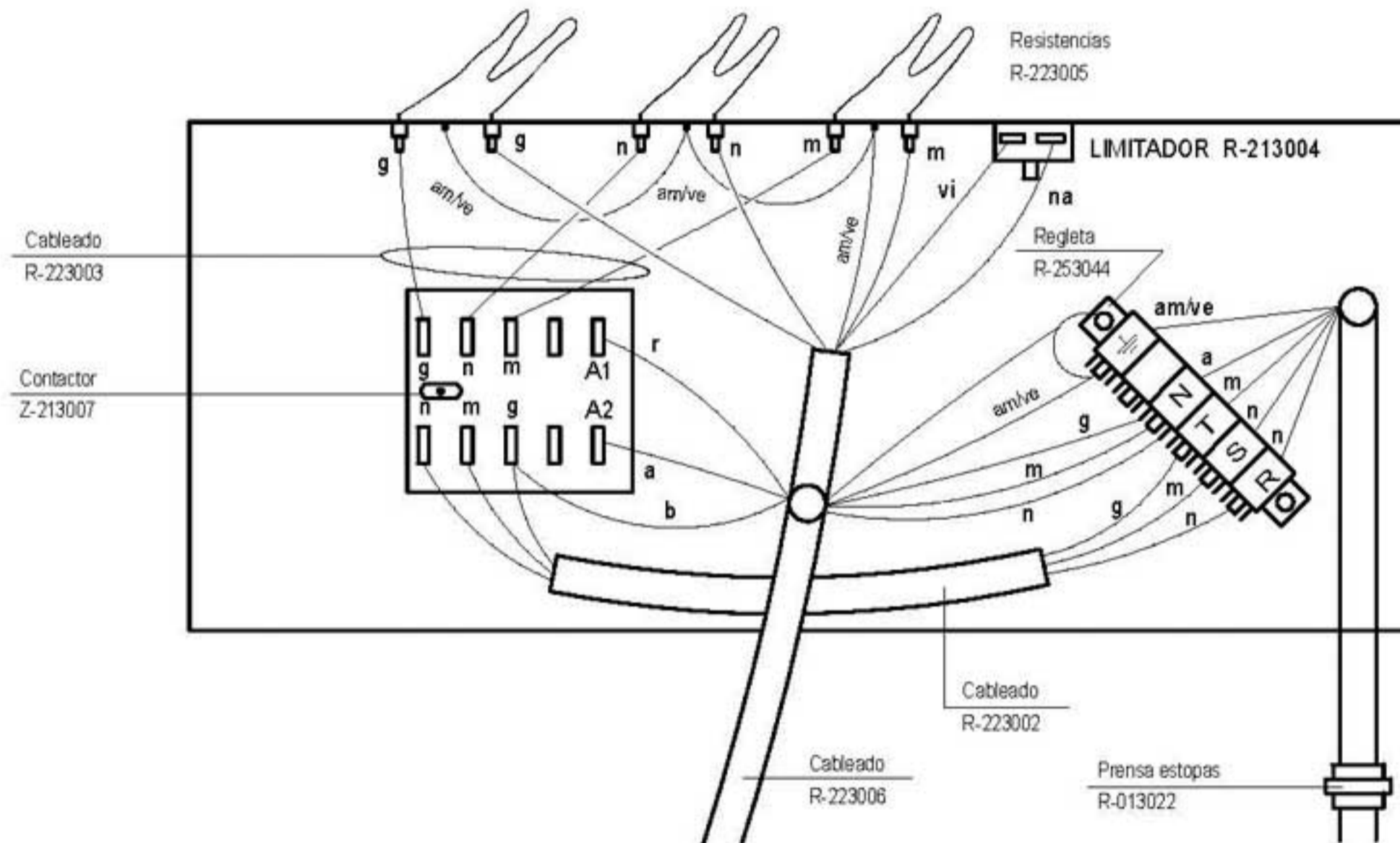

Cableado R-223003

Contactor Z-213007

Resistencias R-223005

LIMITADOR R-213004

Regleta R-253044

Cableado R-223002

Cableado R-223006

Prensa estopos R-013022

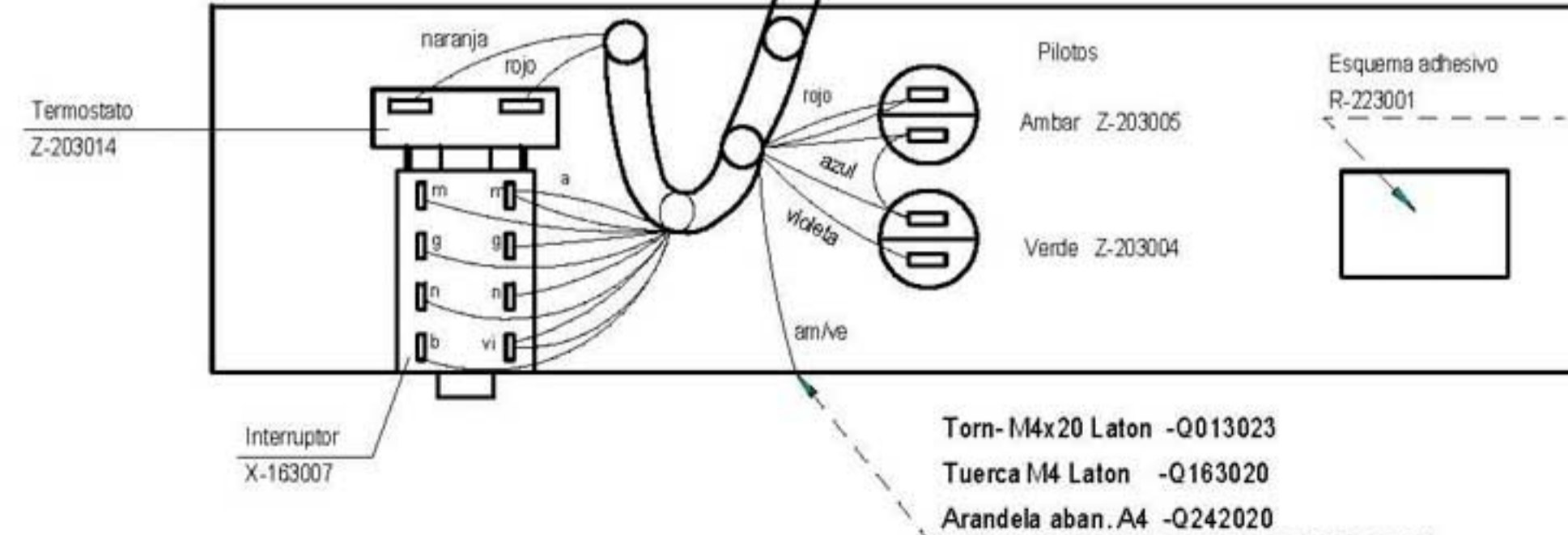

Termostato Z-203014

Pilotos

Ambar Z-203005

Verde Z-203004

Esquema adhesivo R-223001

Interruptor X-163007

Torn- M4x20 Laton -Q013023

Tuerca M4 Laton -Q163020

Arandela aban. A4 -Q242020

1/2 Modulo BME 905 BME-705

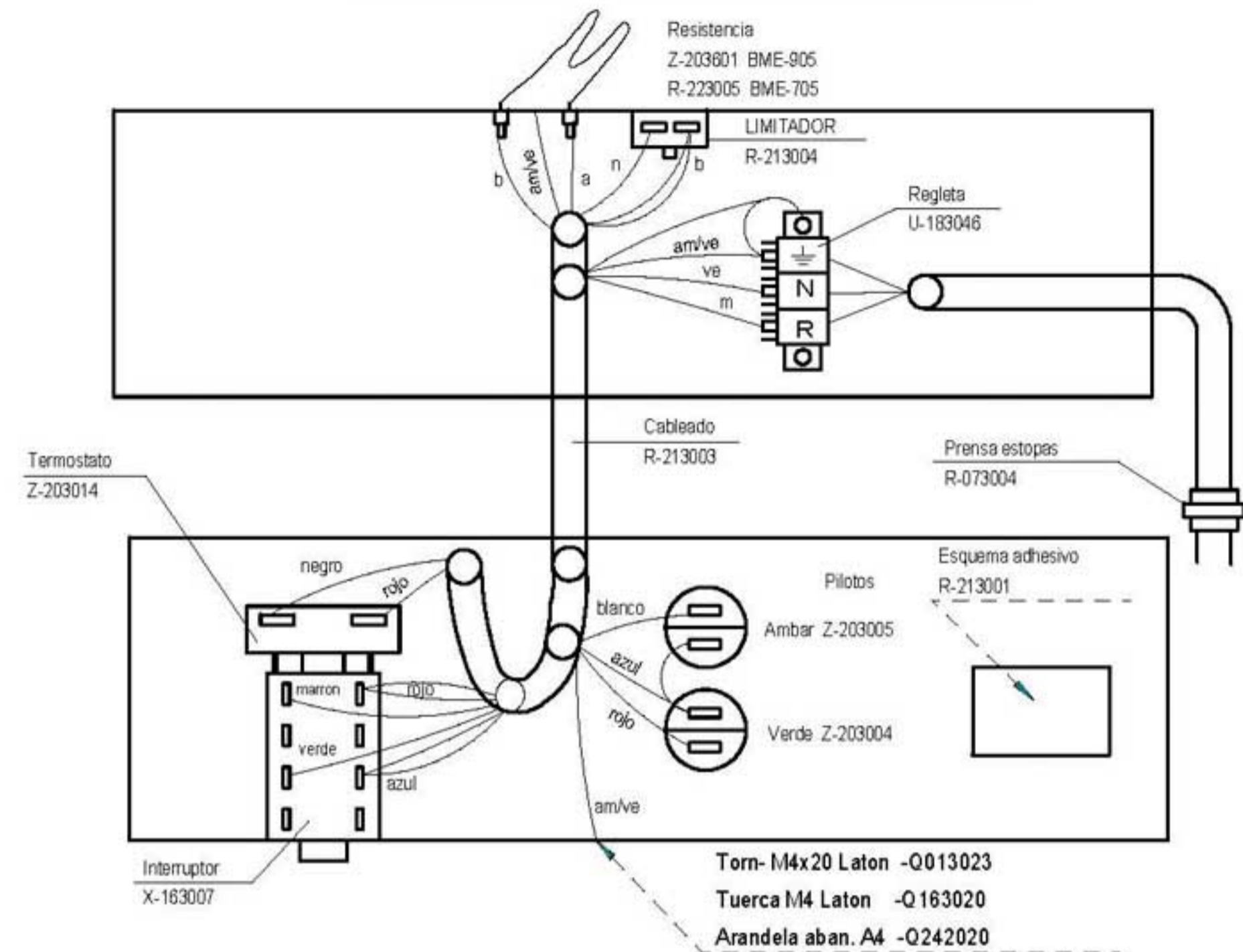

Resistencia Z-203601 BME-905
R-223005 BME-705

LIMITADOR R-213004

Regleta U-183046

Cableado R-213003

Prensa estopos R-073004

Termostato Z-203014

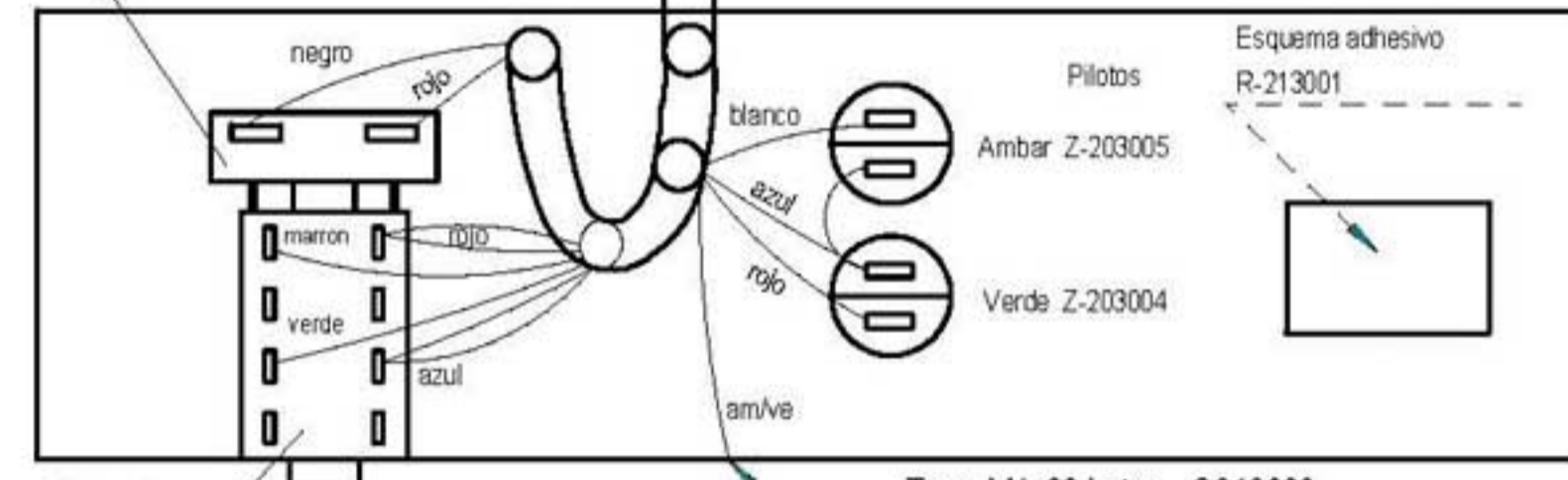

Esquema adhesivo R-213001

Pilotos

Ambar Z-203005

Verde Z-203004

Interruptor X-163007

Torn- M4x20 Laton -Q013023

Tuerca M4 Laton -Q163020

Arandela aban. A4 -Q242020

TOMA EQUIPOTENCIAL

- Q013023-TORNILLO EXAG M4x20 LATON. ---- 1
- Q163020-TUERCA EXAG M4 LATON. 2
- Q221901-TUERCA CUADRADA M4. 1
- Q242040-ARANDELA ABANICO A4 AISI 304. 2
- Q563004-LENGÜETA COMPONENTES. 1
- Z603021-CHAPITA TIERRA. 1
- Z603022-PLACA ASIENTO CONEXION MASA. 1

Esquema montaje		R213002									
Nº	Pieza	Cant.	Material	Nº Clasificacion	Acabado						
Nº	Modificacion		Propuesta de	Fecha	Tolerancias generales						
①	Introducir limitador		ION	99-7-12	<table border="0"> <tr> <td><math>\leq 5 \pm</math></td> <td><math>50-100 \pm</math></td> </tr> <tr> <td><math>5-25 \pm</math></td> <td>> 100±</td> </tr> <tr> <td><math>25-50 \pm</math></td> <td><math>\infty \pm</math></td> </tr> </table>	$\leq 5 \pm$	$50-100 \pm$	$5-25 \pm$	> 100±	$25-50 \pm$	$\infty \pm$
$\leq 5 \pm$	$50-100 \pm$										
$5-25 \pm$	> 100±										
$25-50 \pm$	$\infty \pm$										
Dibujado		Firma	Fecha	Mecanizado superficial							
Proyectado		JON	93-9-13	FAGOR							
Comprobado				Fagor Industrial, Koop Elk, Mugatua							
Escala				Plano numero							
				HC-70370 -1							
				Sustituye al N°							
				Sustituido por							

BME-705

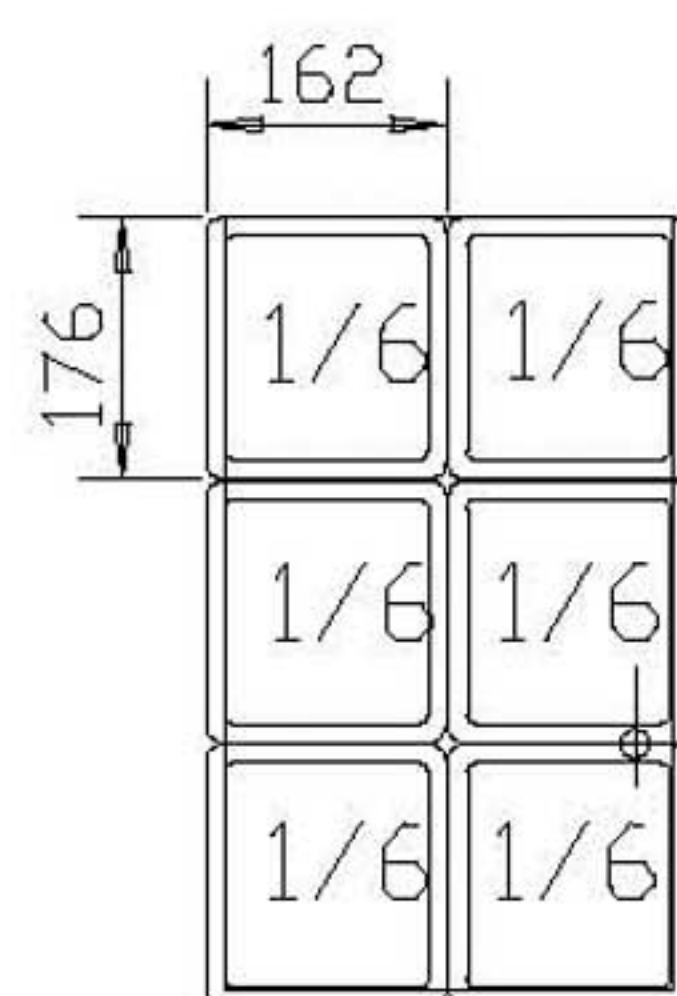
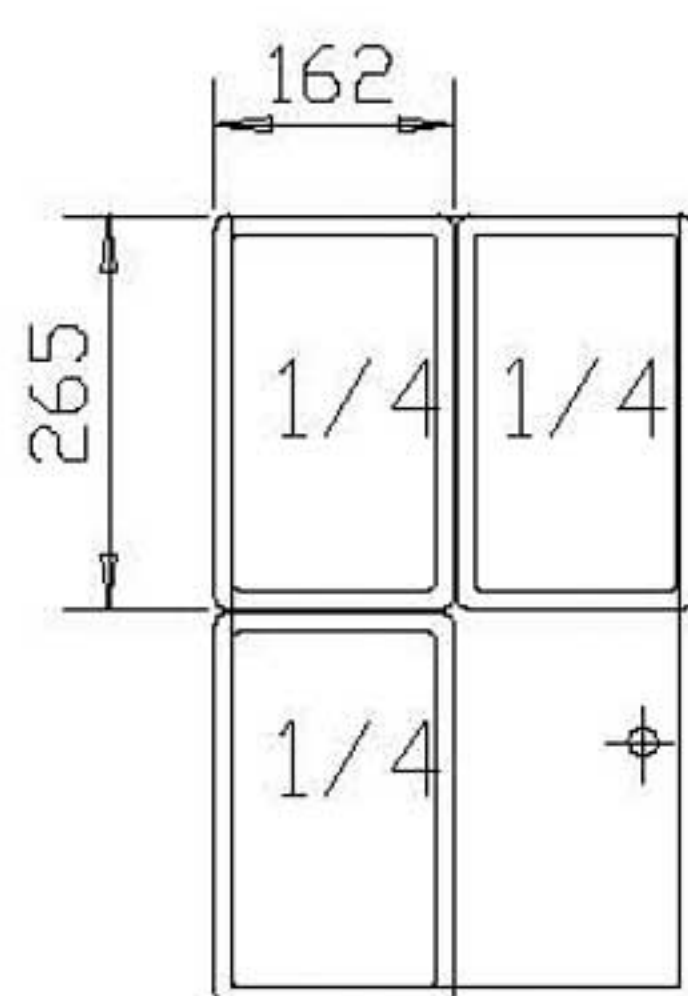
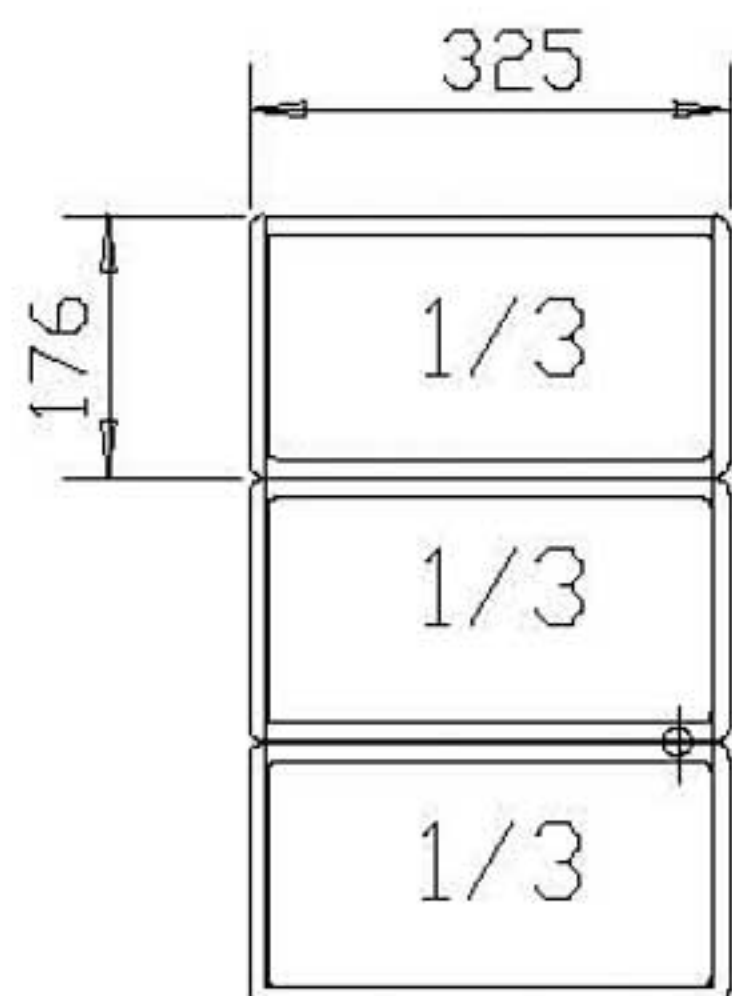
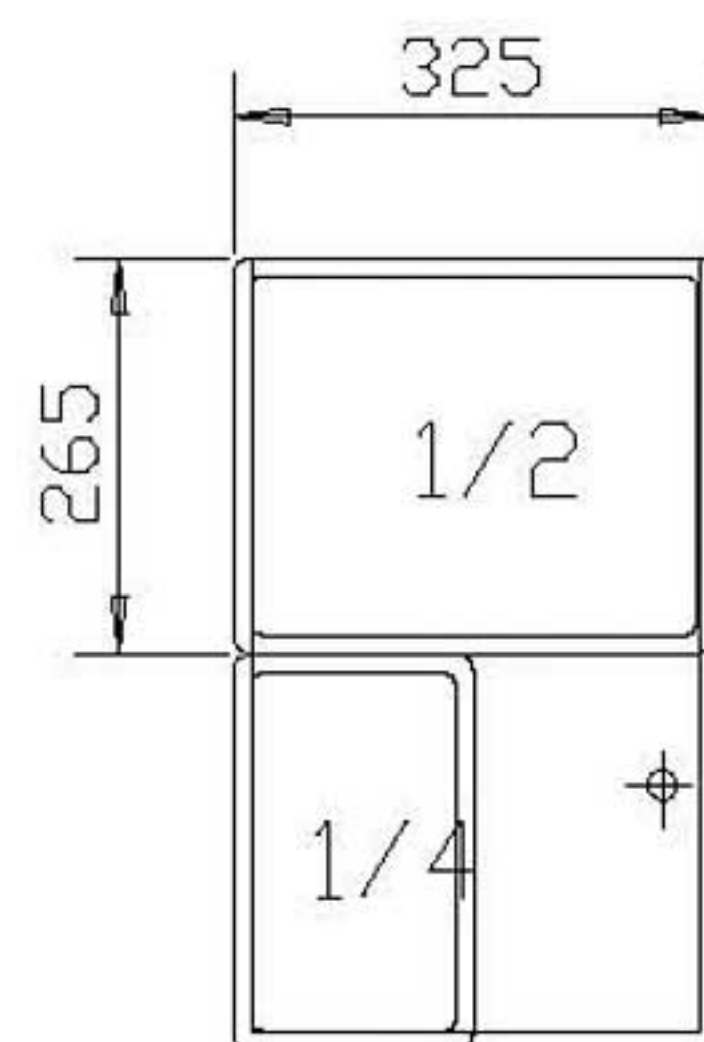
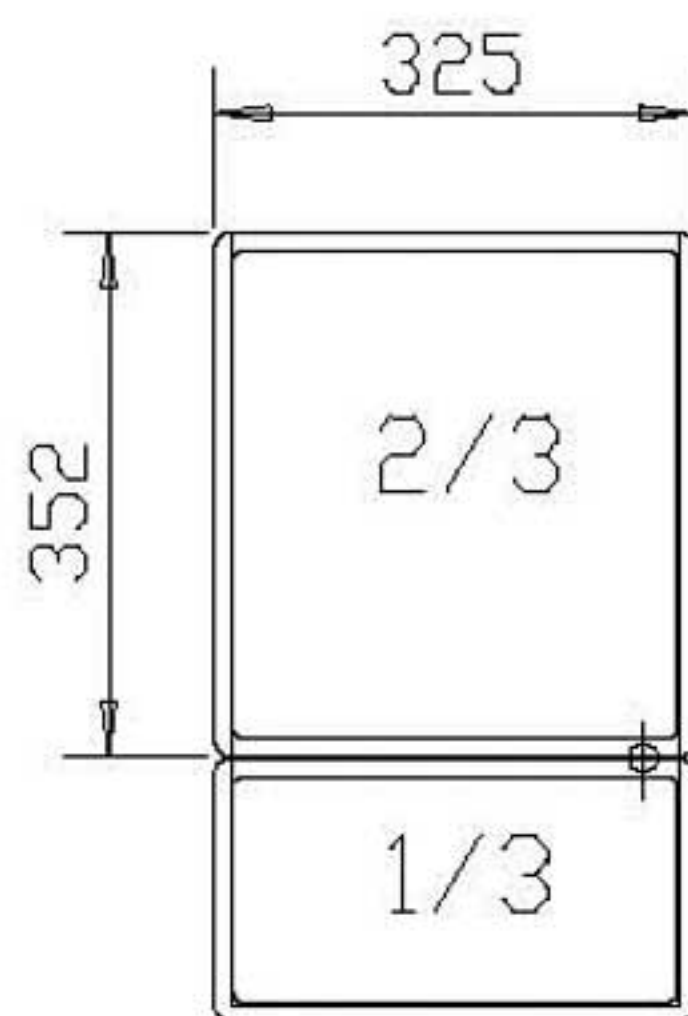
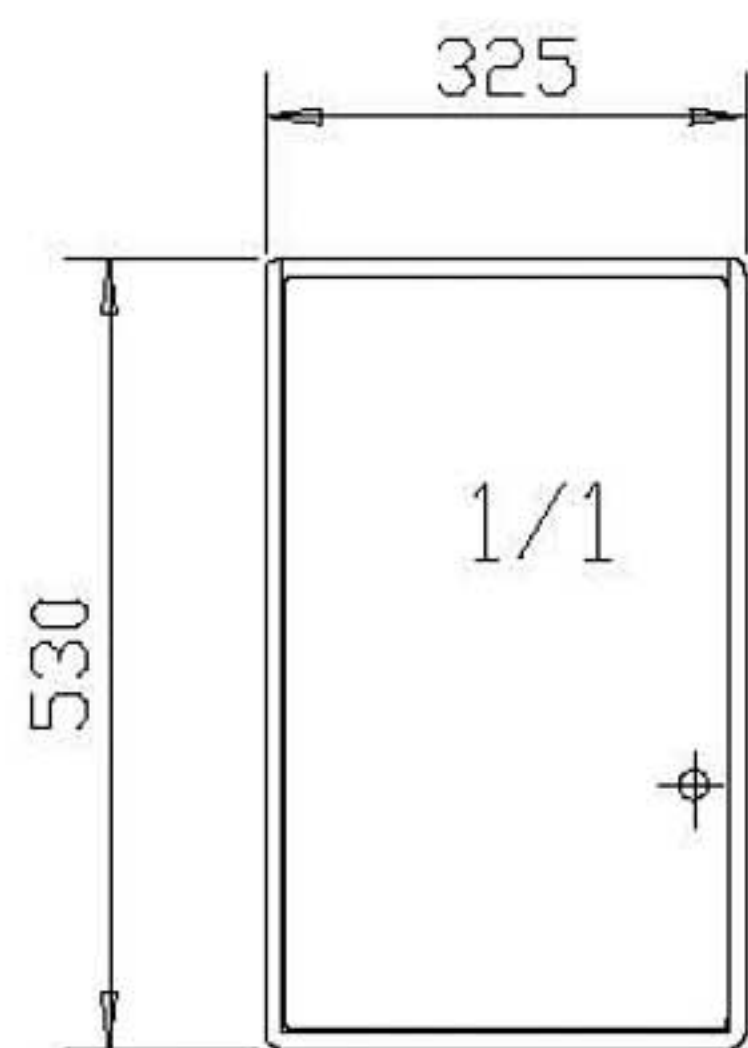

BME-710

