

PARTI DI RICAMBIO
PIECES DETACHEES
SPARE PARTS
ERSATZTEILE
LISTA DE RECAMBIOS

FC 53

10/94

FC 54

10/94

FC 533

01/96

FC 543

10/94

FC 544

10/94

FC HR ...

10/94

FC ... / A

10/94

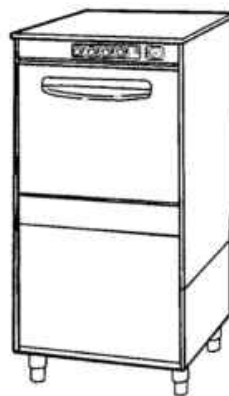

02 - 1999 S. AG.

- 1 Hood 544
- 2 Wash arm
- 3 Rinse arm
- 4 Tank
- 5 Wash
- 6 Water softener
- 7 Pump
- 8 Rinse aid injector
- 9 Control box 533 - 543 - 544
- 10 Control panel with electronic timer
- 11 Drain pump
- 12 Detergent dispenser

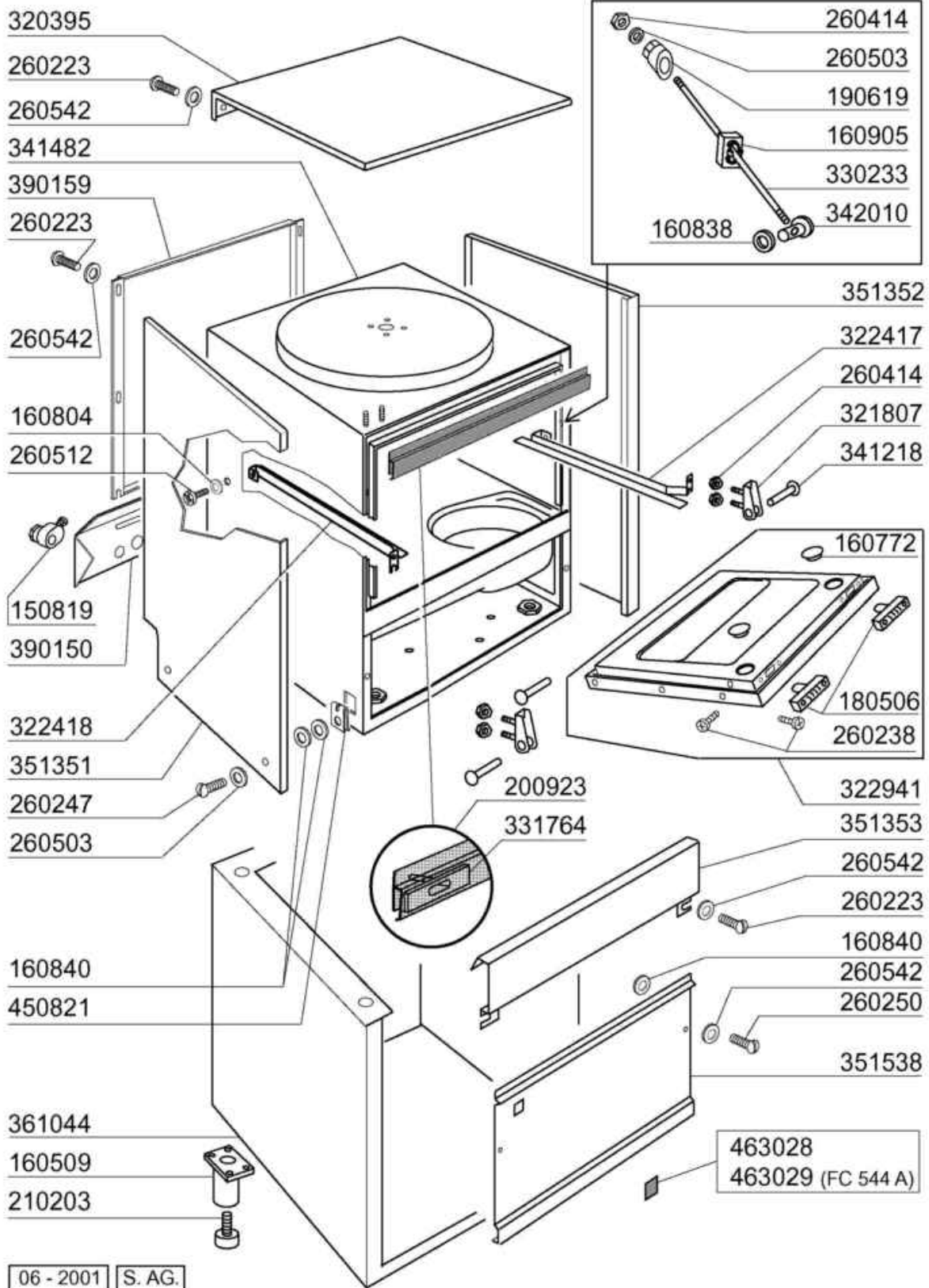

Code	Description
150819	CABLE HOLDER PG16 WITH HOLE
160509	FOOT SUPPORT
160772	PLUG FOR DOOR (BR-BC-FC)
160804	GASKET D.6
160838	SLIDING WASHER TIE ROD FC
160840	WASHER
160905	SLIDING PLATE F. TIE ROD
180506	DOOR CATCH BR-BC-FC
190619	DOOR CATCH B-F-R
200923	DOOR GASKET
210203	RUBBER FOOT 30 MM
260223	M5X12 MSH/HD SCREW SPECIAL S/S
260238	M4 X 10 MUSH/HD SCREW
260247	SCREW TCB 5X16
260250	SCREW TB 5X20
260414	SELF-LOCKING NUT M5
260503	STAINL.STEEL FLAT WASHER D5 UN
260512	ST/ST GROWER WASHER D6
260542	WASHER D.5
320395	TOP PANEL FC
321807	DOOR HINGE FC MACHINES
322417	RIGHT GUIDE FC
322418	LEFT GUIDE FC
322941	DOOR FC54-543-544-HR
330233	FC DOOR TIE ROD
331764	FIXING PLATE FOR B-F DOOR GASK
341218	HINGE PIN B-F-G
341482	HOOD FC54-543-544-HR
342010	PIN FOR TIE ROD DOOR FC
351351	LEFT PANEL FC54-544-543-HR
351352	RIGHT PANEL FC54-543-544-HR
351353	FRONT PANEL FC
351538	FRONT LOWER PANEL FC544
361044	BASEMENT
390150	LOWER BACK PANEL FC
390159	BACK PANEL FC54A
450821	SPRING CLIP FASTENER SNU 3634
463028	FC544 NAME
463029	FC544A NAME

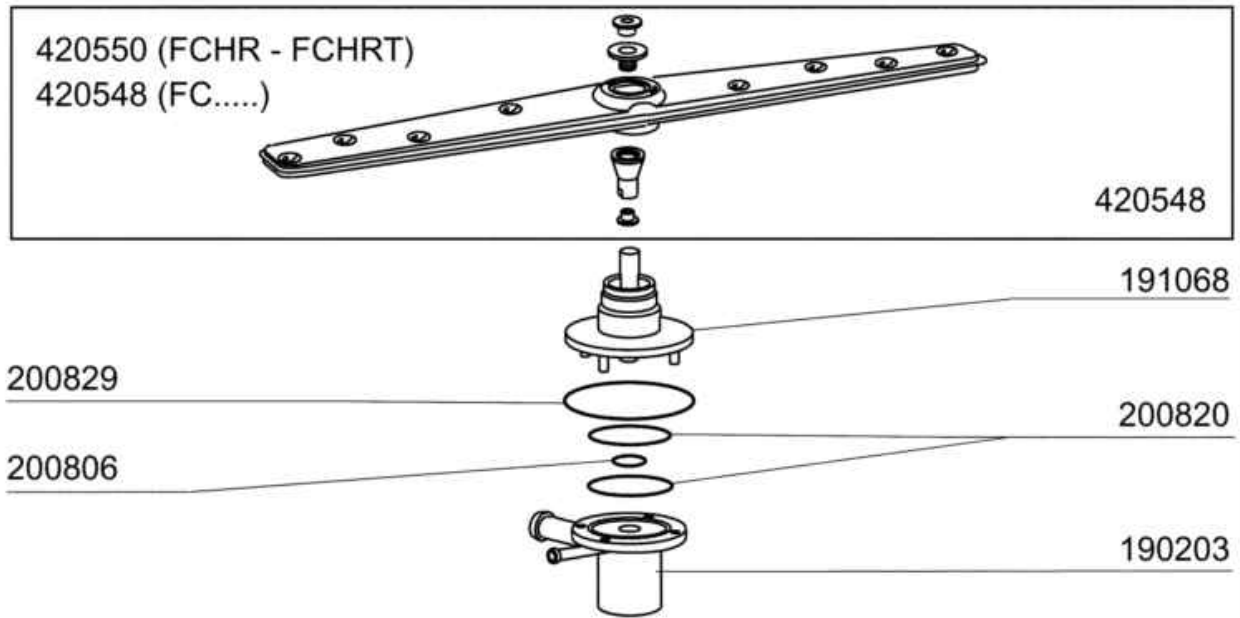
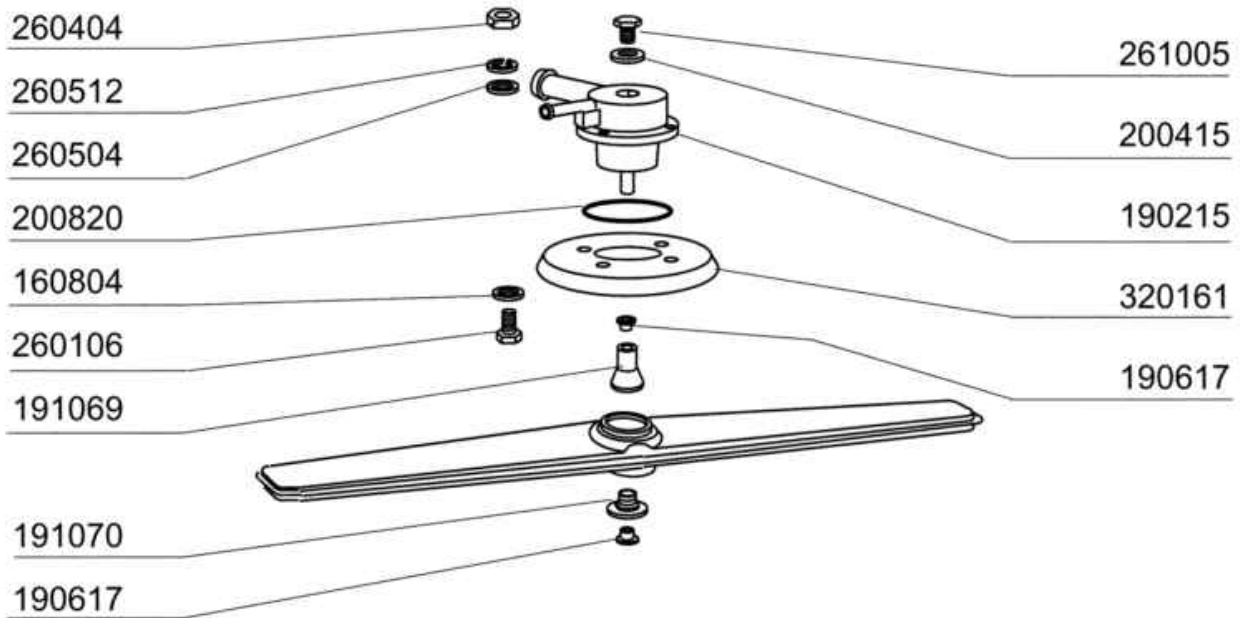

05 - 2000 S. AG.

Code	Description
160804	GASKET D.6
190203	LOWER TEE WASH-RINSE F2-45-55-
190215	UPPER WASH/RINSE ARM SUPPORT F
190617	BUSH
191068	LOWER WASH ARM SUPPORT FC-MACH
191069	WASH ARM CENTER (FC - MACHINES
191070	LOCK NUT FOR WASH ARM CENTER (
200415	AIR TRAP GASKET -F2 18,5X10X3
200806	O-RING 2,62X13,10X18,34
200820	O-RING151 46,99X5,33X57,6
200829	O-RING 81,92X92,58X5,33
260106	SCREW TE 6X25
260404	STAINLESS STEEL NUTS D6 UNI 55
260504	ST/ST FLAT WASHER D6
260512	ST/ST GROWER WASHER D6
261005	SCREW F. TEE UP.WASH F2-B41
320161	UPPER WASH ARM PROTECTION
420548	FC WASH ARM (ST/ST)
420550	WASH ARM FCHR - FCHRT

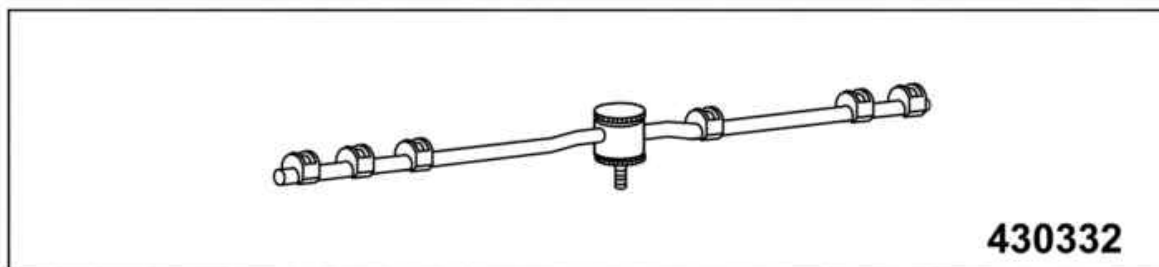
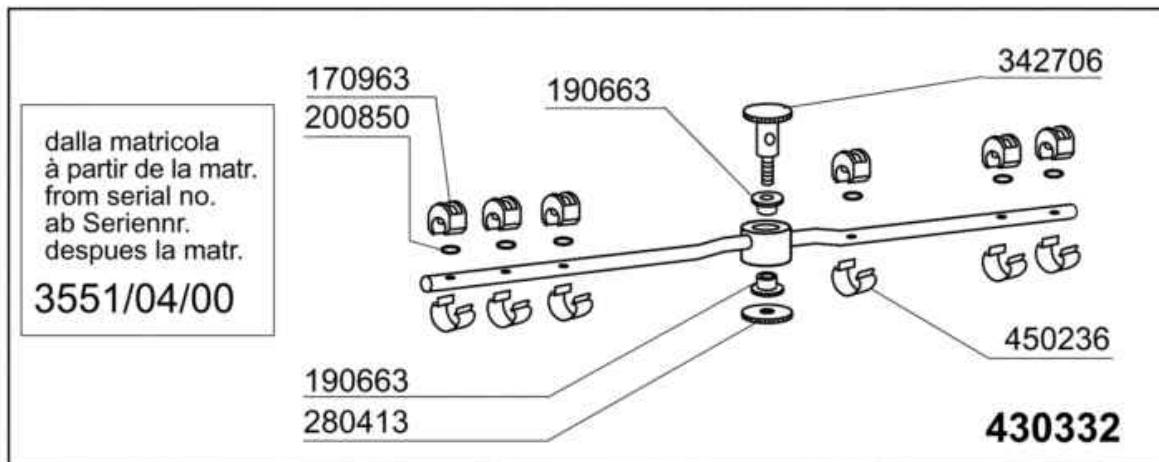
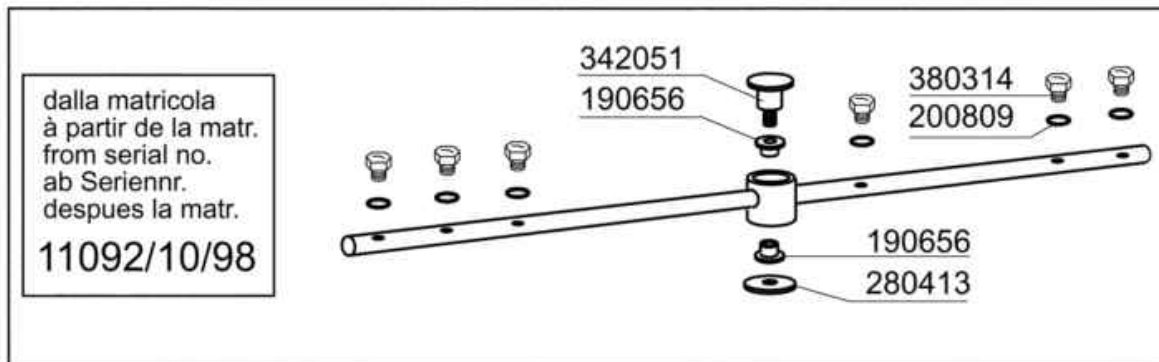
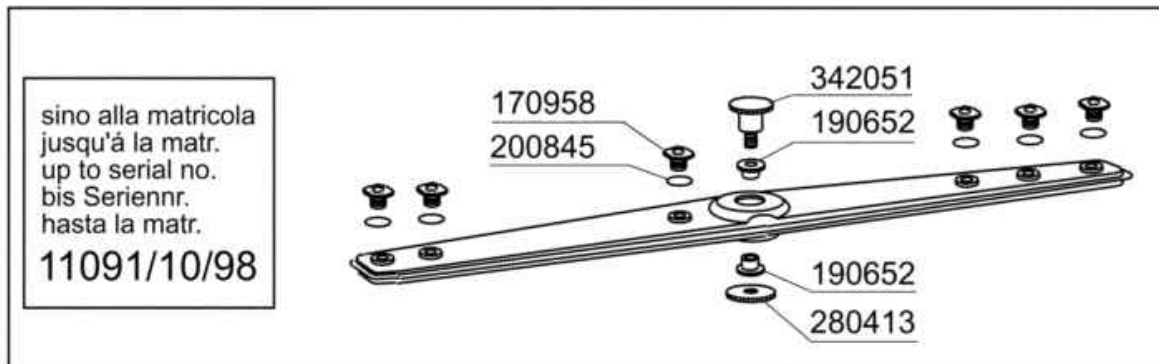

Code	Description
170958	RINSE JET FOR FC53-543
170963	RINSE JET X FC
190652	RINSE ARM BUSH FC
190656	BUSH RINSE ARM FC
190663	BUSH
200809	OR GASKET 1,78X8,73X12,29
200845	O RING 109 2,62X9,13X14,37
200850	O-RING
280413	RETAIN.LOCK NUT FOR FC RINSE A
342051	RINSE ARM SUPPORT FC
342706	SHAFT
380314	RINSE JETS 801/HR
430332	RINSE ARM FC 01/00
450236	SPRING FOR WASHER 170963

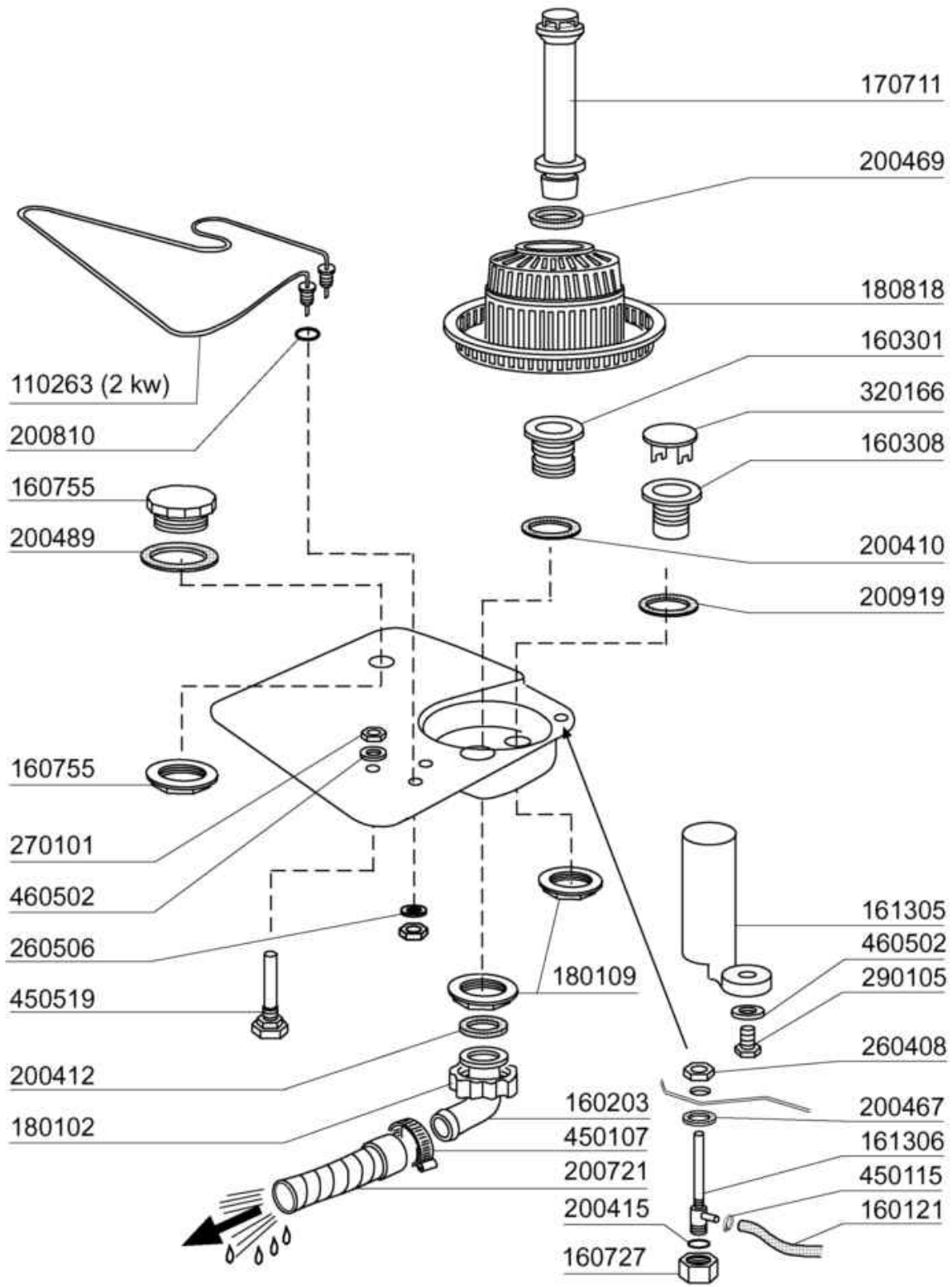

05 - 2002 S. AG.

Code	Description
110263	TANK HEATER 2000W 230V
160121	HOSE EPDM D. 5 X 9
160203	ELBOW 1"1/2 N-S-F-C /DRAIN
160301	DRAIN OUTLET 1"1/2 C-S-N
160308	PUMP INLET HOSE FC
160727	PLUG 1/2 NTP CAP
160755	PLUG FOR MACHINES WITHOUT SOFT
161305	AIR CHAMBER F45-F80
161306	HOSE FOR AIR CHAMBER F45-80
170711	OVERFLOW PIPE FC
180102	DRAIN PIPE NUT 1"1/2 F45-55
180109	LOCK NUT 1 1/2"
180818	STRAINER FOR FC
200410	DRAIN OUTL.WASH.1 1/2"65X47X2
200412	GASKET DRAIN 1 1/2" 45X33X3
200415	AIR TRAP GASKET -F2 18,5X10X3
200467	DUTRAL GASKET F. AIR TRAP
200469	STAND PIPE O RING 45X35,5X7
200489	GASKET 81X68X3
200721	DRAIN HOSE 28X35 3MT.
200810	O-RING 2,62X9,92X15,6 F.GLASSW
200919	GASKET FOR SUCTION BASIN FC
260408	S/S NUTS D.12
260506	STAINL.STEEL FLAT WASHER D10
270101	HEXAGON LOCK NUT 1/2"
290105	BRASS-TE-PLUG 1/2"
320166	VORTEX BREAKER FOR FC MACHINES
450107	CLAMP FE ZN 38-50 H=12,2
450115	ELASTIC CLAMP D.8,3/7,8
450519	TANK THERMOSTAT SHIELD C-F
460502	GASKET 30X21X2

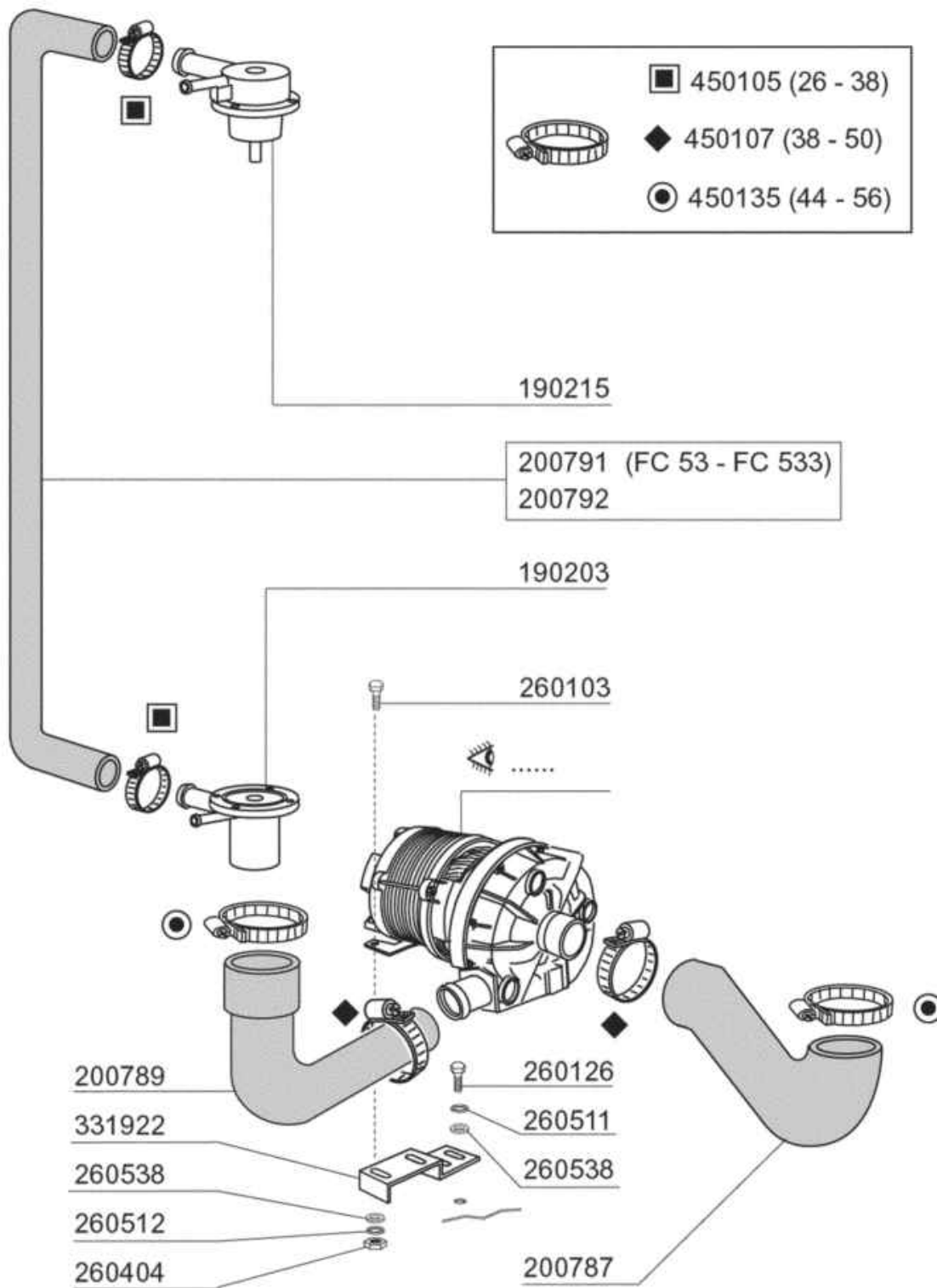

05 - 2001 S. AG.

Code	Description
190203	LOWER TEE WASH-RINSE F2-45-55-
190215	UPPER WASH/RINSE ARM SUPPORT F
200787	INLET HOSE FC53-FC544-FCHR
200789	OUTLET HOSE FC
200791	UPPER/LOWER WASH HOSE FC53
200792	HOSE FOR UPPER/LOWER WASH FC54
260103	SCREW TE 6X12
260126	SCREW TE 5X12
260404	STAINLESS STEEL NUTS D6 UNI 55
260511	GROWER WASHER D.5
260512	ST/ST GROWER WASHER D6
260538	WASHER 18X6X1,5 ST/ST
331922	BRACKET F. PUMP "F"
450105	CLAMP FE ZN. 26-38 H=12,2
450107	CLAMP FE ZN 38-50 H=12,2
450135	CLAMP FE ZN. 44-56 H=12,2

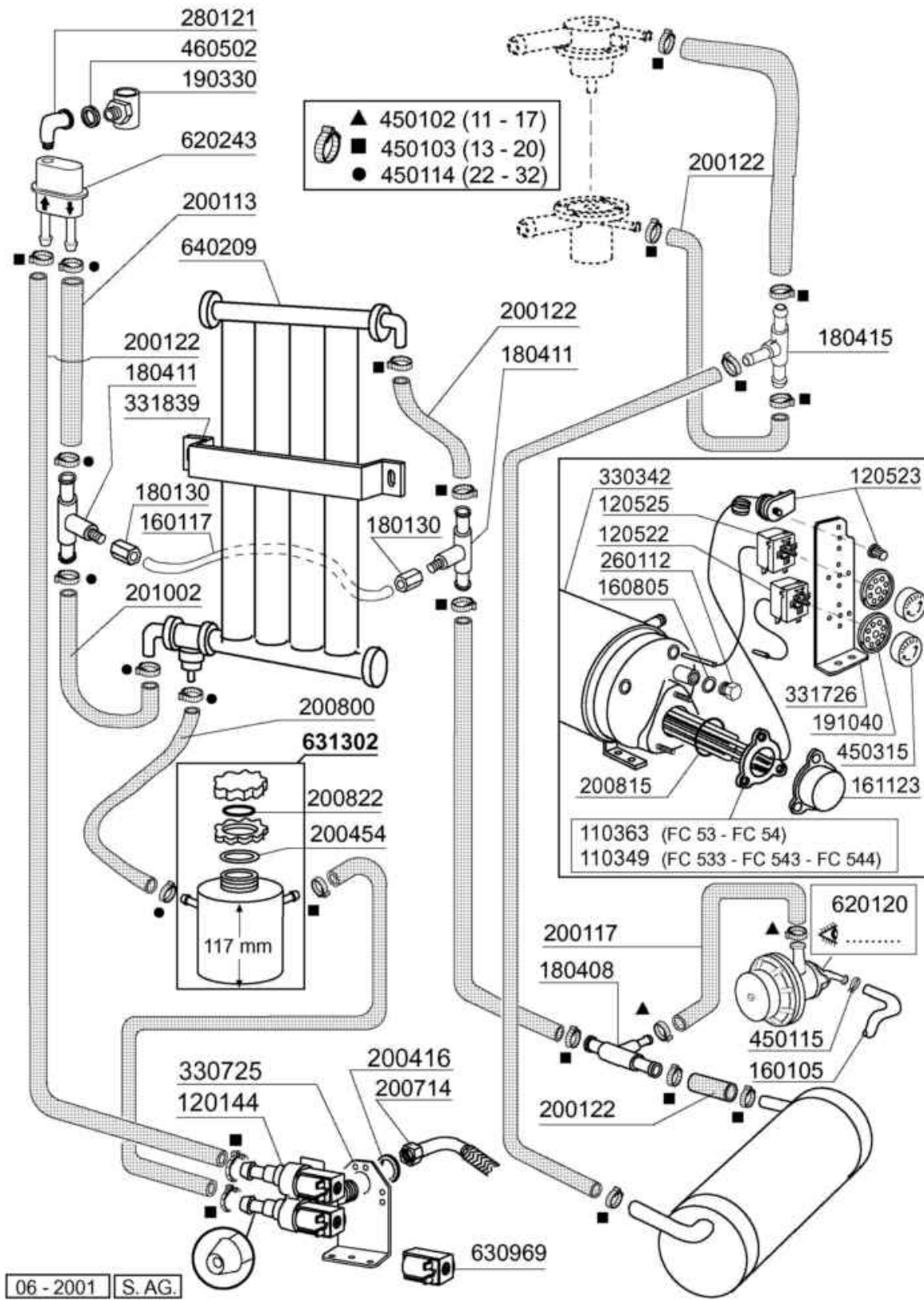

06 - 2001 S. AG.

Code	Description
110349	HEAT.ELEMENT 6000W 230/400V
110363	HEATING ELEMENT 3000W 230V
120144	SOLENOID VALVE FCA 20 LT TYPE
120522	TANK THERMOSTAT 90?
120523	SAFETY THERMOSTAT 110?
120525	BOOSTER THERMOSTAT 2 TEMPERAT.
160105	INJECT.INLET HOSE D.6X4
160117	HOSE 6,3X1,1 WITHE
160805	GASKET D.8
161123	HEAT.ELEMENT COVER H42 SNL
180130	CONNECTION NUT FOR BY PASS (1/
180408	TEE-NIPPLE F.INJECT.W/CENTR.RE
180411	TEE-NIPPLE FOR BY PASS "BTM"
180415	TEE NIPPLE DOUBLE "T"
190330	TEE FOR VAACUM BREAKER
191040	FRAME F.THERMOSTAT KNOB
200113	RUBBER HOSE 12 X 22
200117	RUBBER HOSE 7X16
200122	HOSE 11X19
200416	GASKET D. 3/4"
200454	GASKET F. SALT CONT.
200714	GLASSWASHER INLET HOSE
200800	HOSE FOR SALT CONTAINER
200815	O-RING F. HEAT. ELEM.
200822	PLUG GASKET OF SALT CONTAINER
201002	HOSE
260112	STAINLESS STEEL TE-SCREW 8X16
280121	ELL FOR VAACUM BREAKER
330342	BOILER C1000/1300-FC-LC
330725	STANDARD BRACKET F.SOLEN.VALV
331726	BRACKET FOR 3 THERMOSTATS
331839	BRACKET FOR WATER SOFTENER
450102	CLAMP FE ZN 11-17 H=9
450103	CLAMP FE ZN. 13-20 H=9
450114	CLAMP FE ZN.22-32 H=12,2
450115	ELASTIC CLAMP D.8,3/7,8
450315	KNOB F. THERMOSTAT 90?
460502	GASKET 30X21X2
620120	RINSE AID INJECTOR
620243	VACUUM BREAKER (WITHOUT KIT)
630969	COIL S4216 220/50HZ
631302	SALT CONTAINER
640209	WATER SOFTENER (4 COLUMNS)

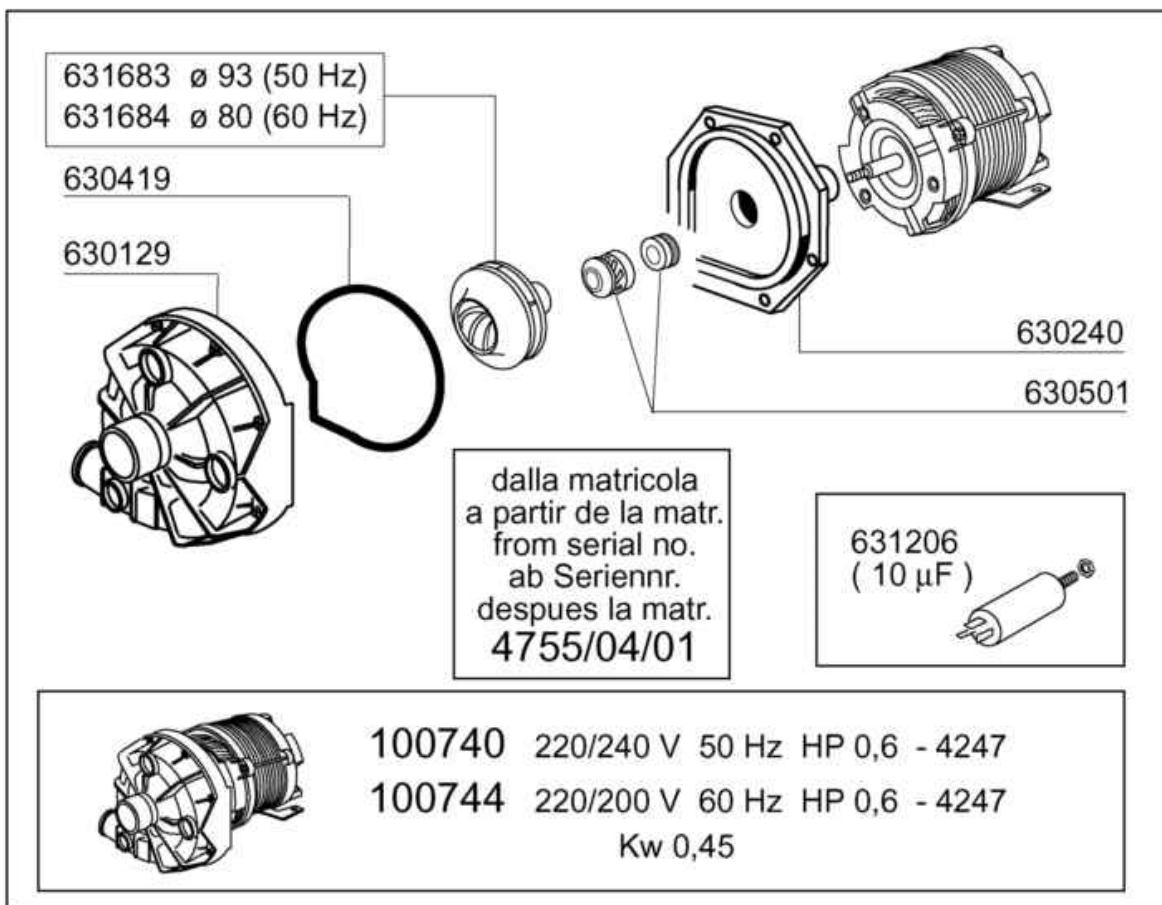
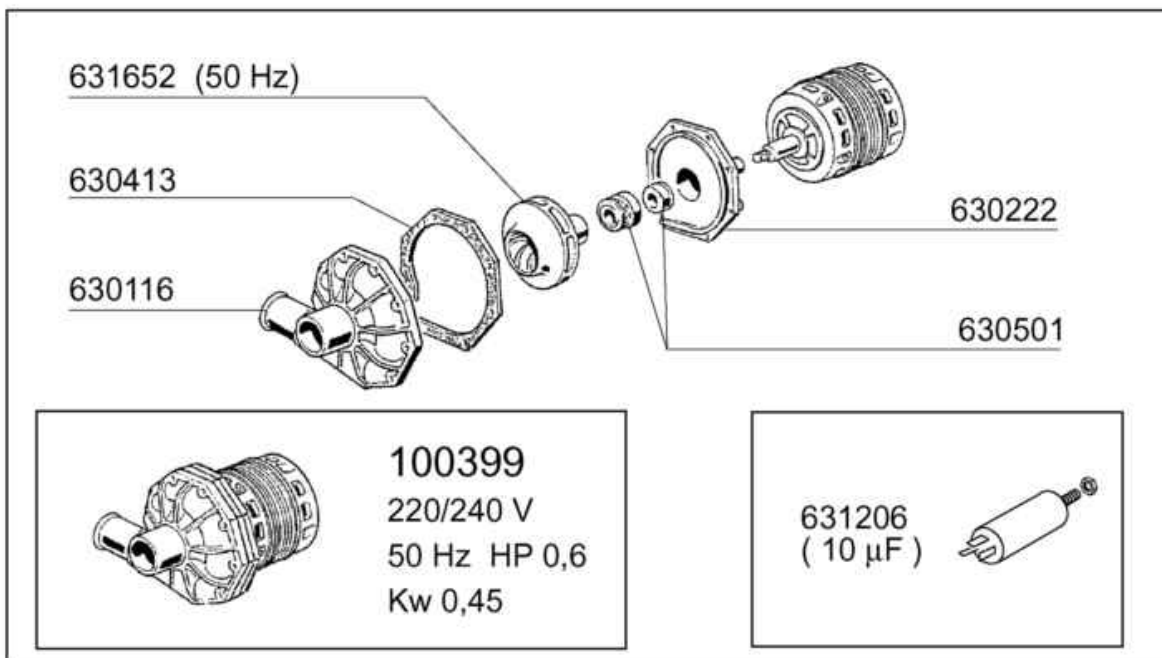

05 - 2001 | S.AG.

Code	Description
100399	PUMP HPO,6 220-50HZ (100740)
100740	PUMP 0,6HP 220/240V 4247
100744	PUMP HP 0,6 200-220-60HZ
630116	-NO MORE AVAILABLE
630129	VOLUTE PUMP 0,5HP 2247
630222	COVER PUMP IB HP 0,4
630240	PUMP FLANGE 0,6HP-4247 FIR
630413	-NO MORE AVAILABLE
630419	PUMP GASKET 2247 0,5HP
630501	SEAL FOR PUMP HP 2-3-3,2
631206	CONDENSER 10MF. 450V 85C
631652	-NO MORE AVAILABLE
631683	PUMP IMPELLER 50HZ FIR 4247
631684	IMPELLER FOR PUMP 60 HZ

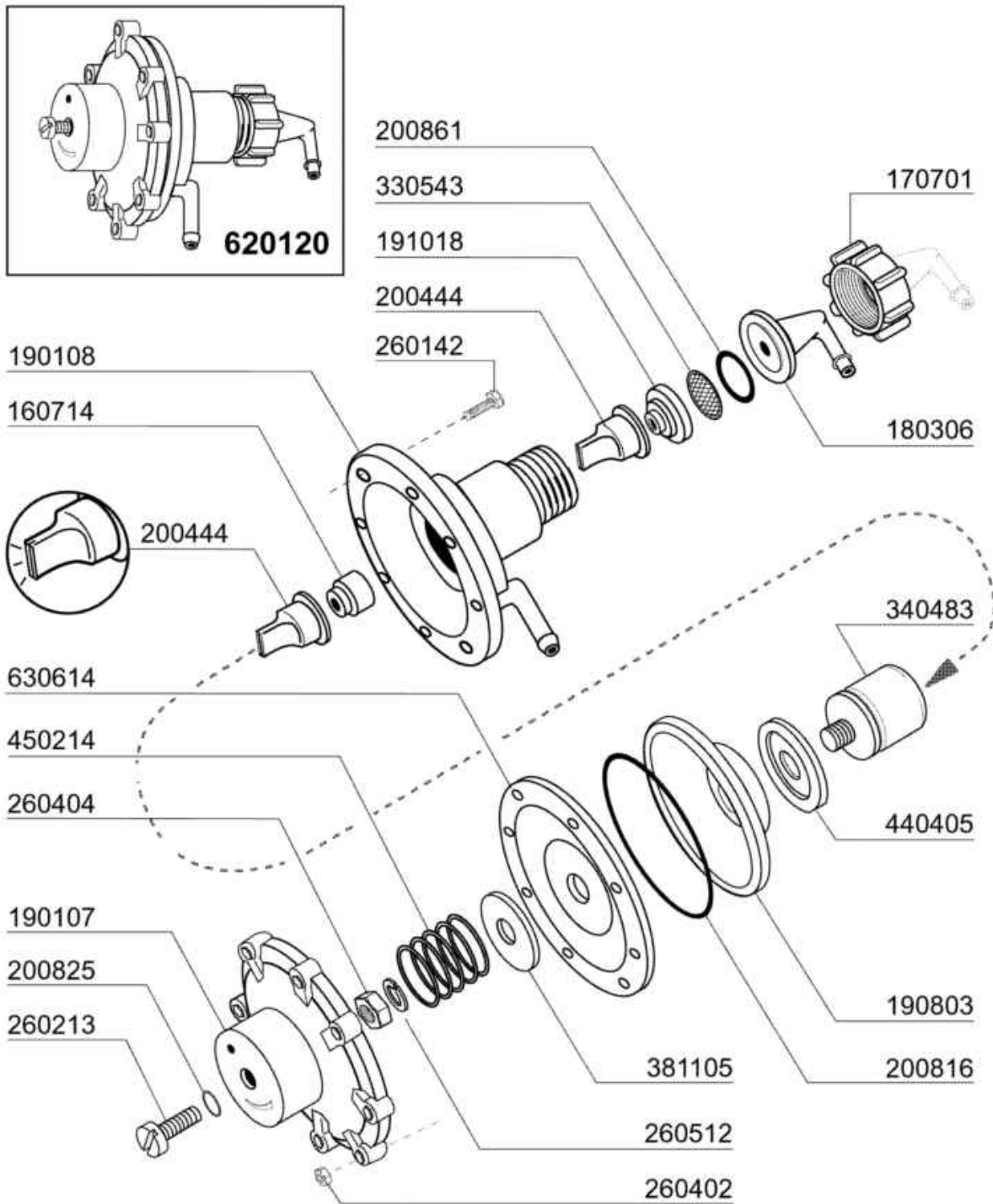

02 - 2004 | S. AG.

Rinse aid injector

Code	Description
160714	PLUG FOR RINSE AID INJECTOR MO
170701	LOCK NUT 1/2" F.INJECTOR
180306	NIPPLE F.RINSE AID INJECTOR
190107	COVER FOR RINSE AID DISPENSER
190108	VOLUTE FOR RINSE AID DISPENSER
190803	GASKET SUPPORT RING F.INJECT
191018	FILTER SUPPORT RINSE AID INJEC
200444	SUCTION VALVE RINSE INJECTOR
200816	O-RING 2,5X59,2X64,2 RINSE INJ
200825	O-RING 3X5X11 RINSE INJECTOR
200861	O-RING 14X18X2
260142	SCREW TE 4X16
260213	SCREW TCP 5X25
260402	STAINLESS STEEL NUT D4 UNI 55
260404	STAINLESS STEEL NUTS D6 UNI 55
260512	ST/ST GROWER WASHER D6
330543	FILTER RINSE AID INJECTOR D.17
340483	PISTON FOR RINSE AID DISPENSER
381105	DIAPHRAGME DISC
440405	GASKET FOR RINSE AID INJ.
450214	SPRING RINSE AID INJECTOR
620120	RINSE AID INJECTOR
630614	DIAPHRAGM RINSE INJECTOR

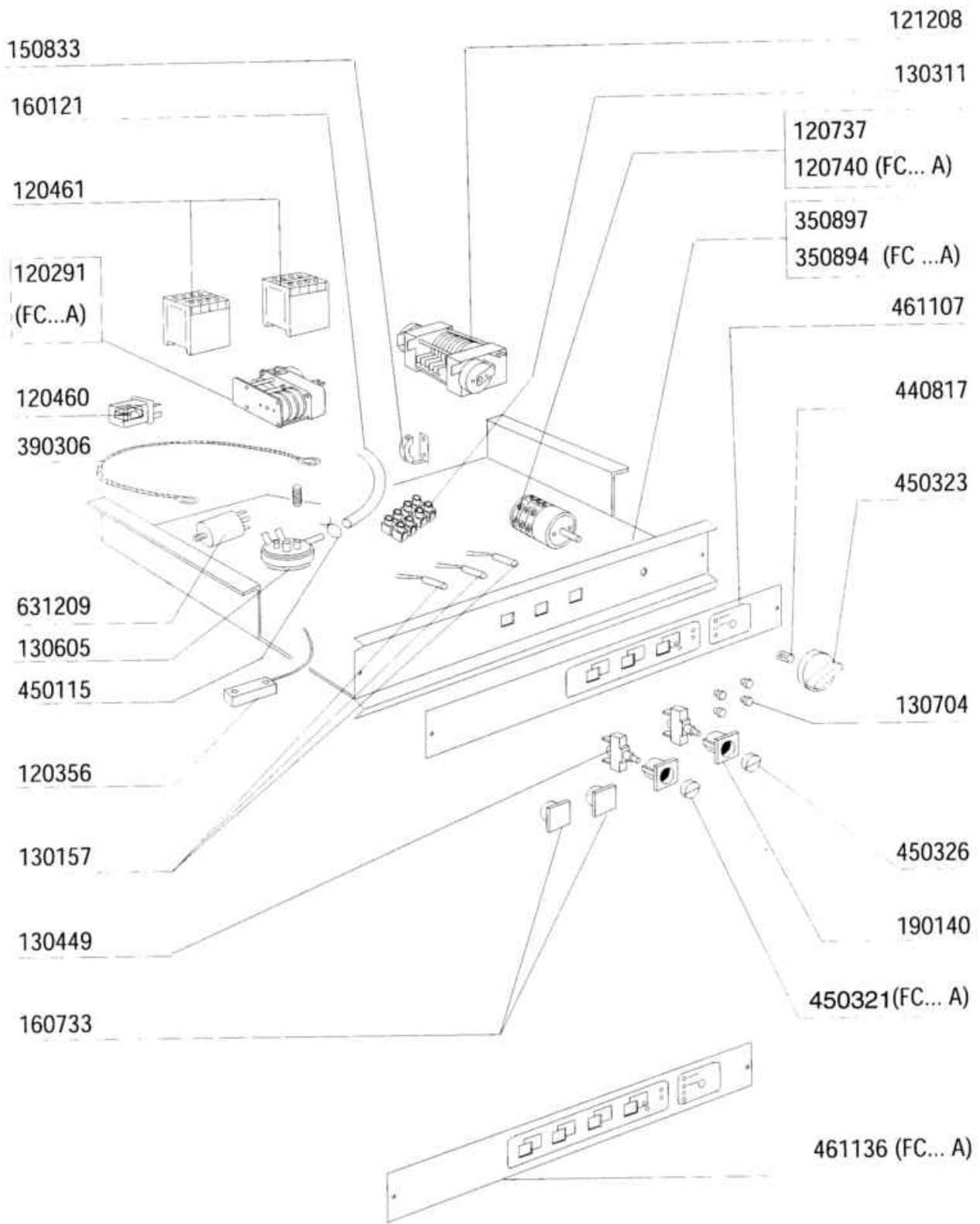

02 - 1999 | S. AG | 02

Code	Description
120291	REGENERATION TIMER 20'
120356	DOOR MAGN.SWITCH
120460	RELAY 16A 220V
120461	CONTACTOR ABB B6-30-01 220V
120737	4 POLE SWITCH 16A 3 POSITIONS
120740	6 POLE MAIN SWITCH 15A-4 POS.
121208	TIMER 100-150"
130157	GREEN LED FOR BR-BC-C-SERIES -
130311	TERMINAL BLOCK
130449	PUSH BUTTON BR-BC-FC
130605	PRESSURE SWITCH 50-30 1 LEVEL
130704	GREEN COLOUR.IND.LAMP COVER
150833	CABLE HOLDER BC/BR
160121	HOSE EPDM D. 5 X 9
160733	BLANK PLATES
190140	BUTTON HOLDER BR-BC-FC
350894	PANEL SUPPORT FC-A
350897	SUPPORT FOR CONTROL PANEL FC
390306	CABLE
440817	SNAP RING LSCB/1853/17/00
450115	ELASTIC CLAMP D.8,3/7,8
450321	GREY COVER FOR PUSH BUTTON BR-
450323	KNOB FOR BC-BR-C95-C155
450326	PUSH BUTTON "CYCLE" GREEN
461107	PLATE FC53-54-543-544
461136	PLATE FC-A
631209	ANTI-NOISE FILTER

Control panel with electronic timer

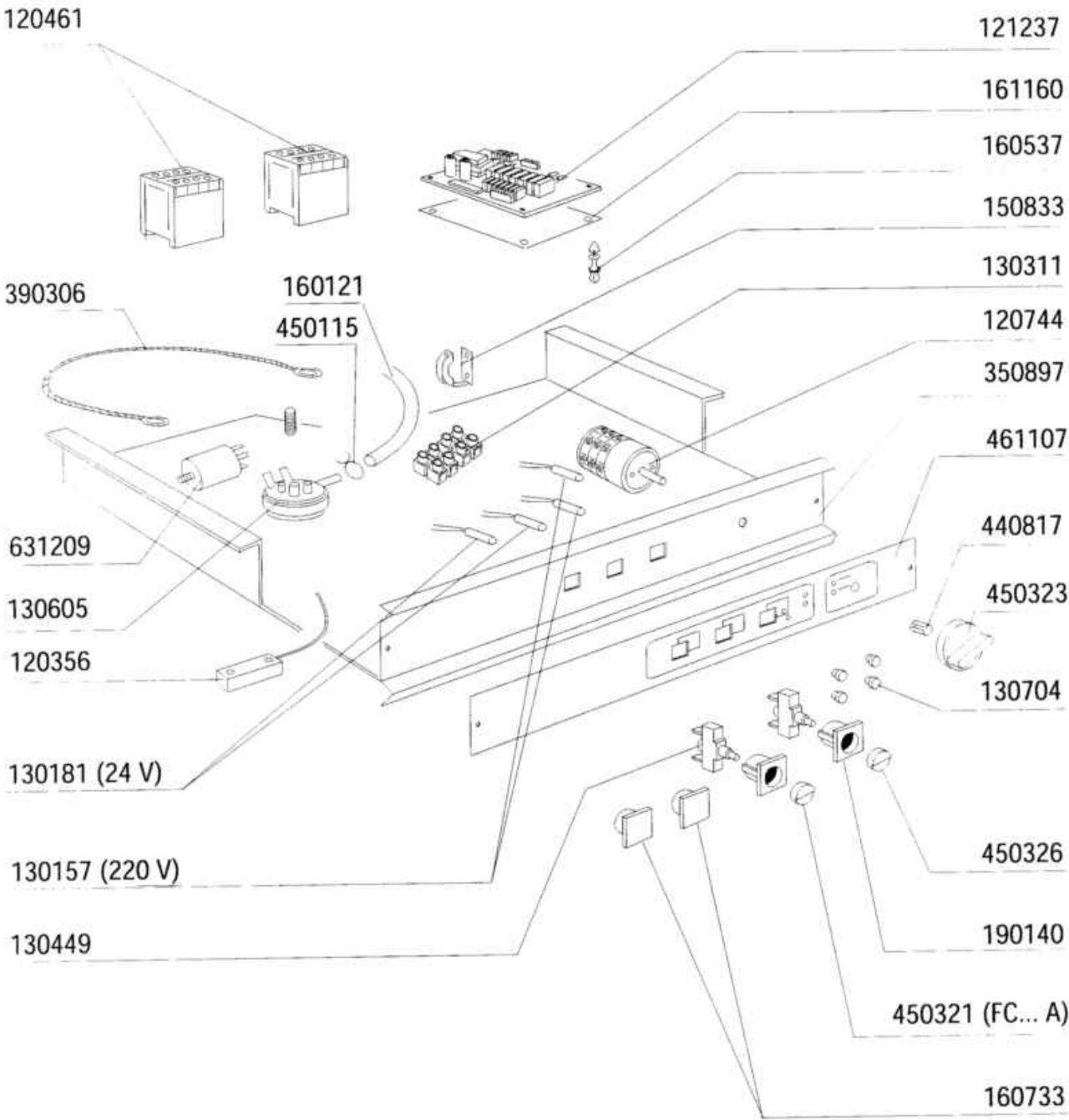

02 - 1999 S. AG 02

Control panel with electronic timer

Code	Description
120356	DOOR MAGN.SWITCH
120461	CONTACTOR ABB B6-30-01 220V
120744	SWITCH QUADRIPOL.16A 380V
121237	ELECTRONIC PCB (FC WITH SOFT.)
130157	GREEN LED FOR BR-BC-C-SERIES -
130181	GREEN LAMP 24V
130311	TERMINAL BLOCK
130449	PUSH BUTTON BR-BC-FC
130605	PRESSURE SWITCH 50-30 1 LEVEL
130704	GREEN COLOUR.IND.LAMP COVER
150833	CABLE HOLDER BC/BR
160121	HOSE EPDM D. 5 X 9
160537	ELECTRONIC CARD SPACER
160733	BLANK PLATES
161160	PROTECTION ELECT.CARD C/F
190140	BUTTON HOLDER BR-BC-FC
350897	SUPPORT FOR CONTROL PANEL FC
390306	CABLE
440817	SNAP RING LSCB/1853/17/00
450115	ELASTIC CLAMP D.8,3/7,8
450321	GREY COVER FOR PUSH BUTTON BR-
450323	KNOB FOR BC-BR-C95-C155
450326	PUSH BUTTON "CYCLE" GREEN
461107	PLATE FC53-54-543-544
631209	ANTI-NOISE FILTER

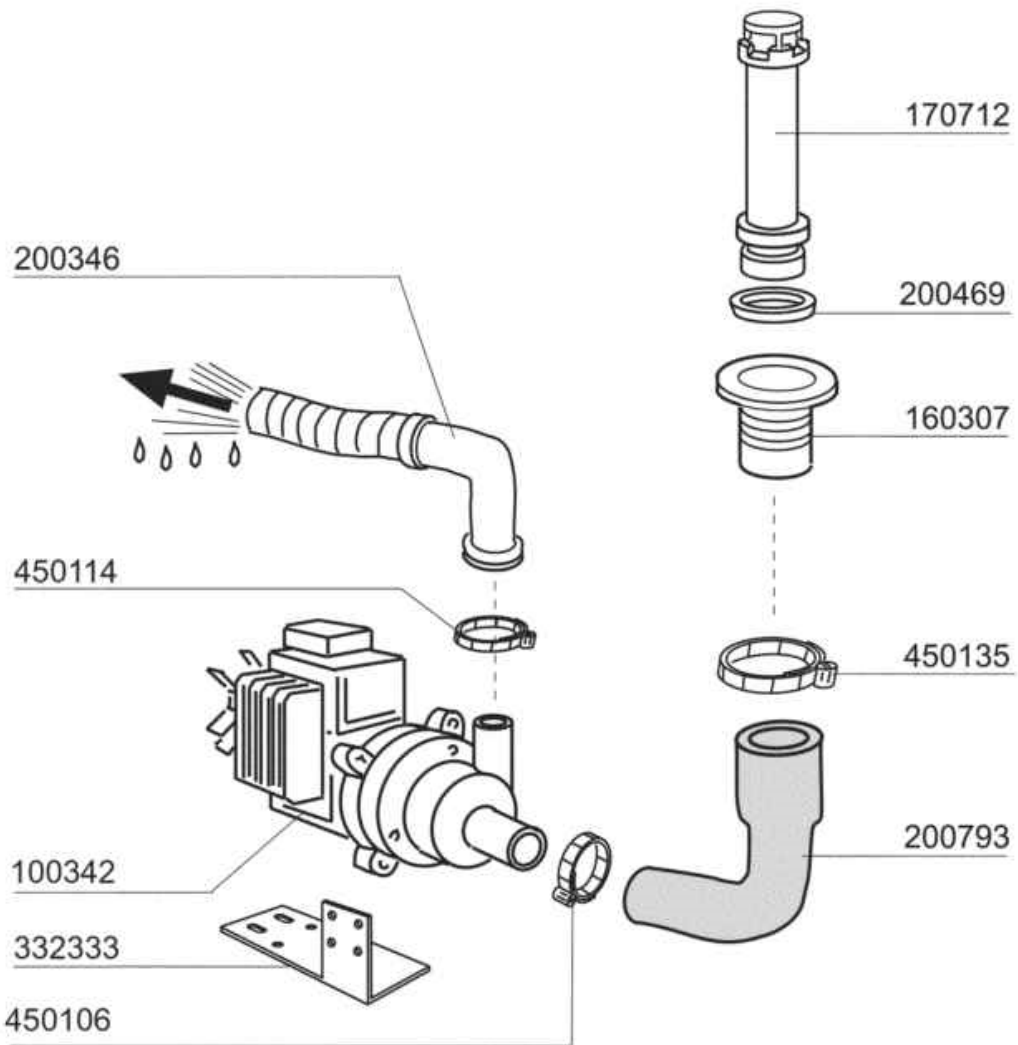
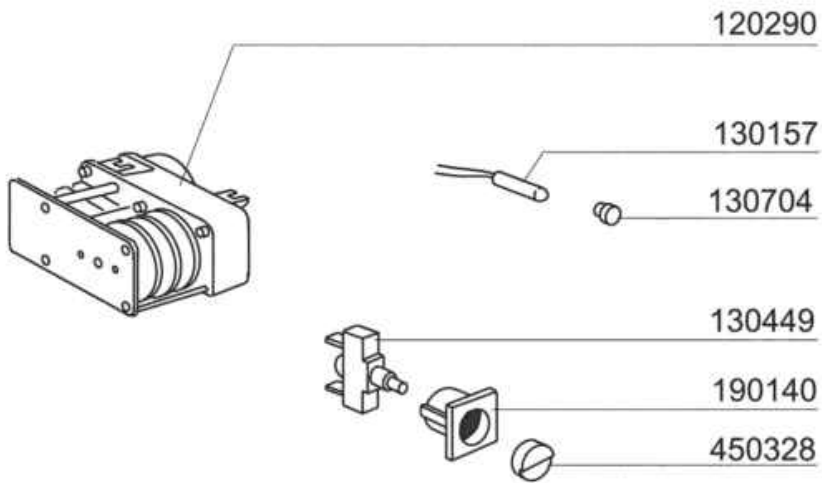

05 - 2001 S. AG.

Code	Description
100342	DRAIN PUMP 100 W 220V
120290	TIMER FOR DRAIN PUMP
130157	GREEN LED FOR BR-BC-C-SERIES -
130449	PUSH BUTTON BR-BC-FC
130704	GREEN COLOUR.IND.LAMP COVER
160307	DRAIN OUTLET FC
170712	OVERFLOW PIPE FOR DRAIN PUMP
190140	BUTTON HOLDER BR-BC-FC
200346	DRAIN HOSE GLASSWASHER
200469	STAND PIPE O RING 45X35,5X7
200793	DRAIN PUMP INLET HOSE FC
332333	BRACKET FOR DRAIN PUMP
450106	CLAMP FE ZN 32-44 H=12,2
450114	CLAMP FE ZN.22-32 H=12,2
450135	CLAMP FE ZN. 44-56 H=12,2
450328	DRAIN SWITCH

620242

200467

251213

260408

200607

180719

10 - 2000 S. AG.

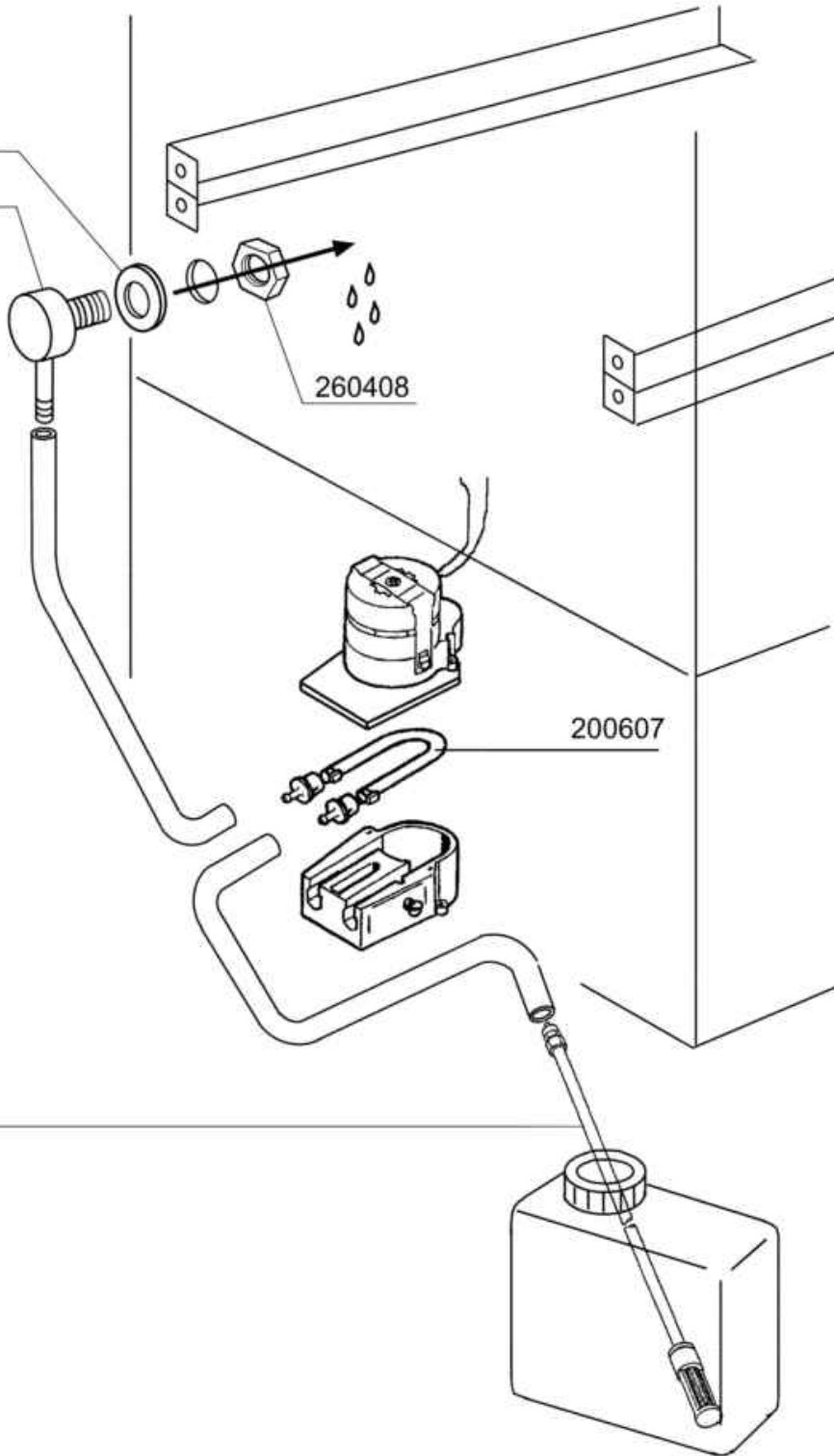

Detergent dispenser

Code	Description
180719	DETERGENT DISPENSER SUCTION HO
200467	DUTRAL GASKET F. AIR TRAP
200607	DETERGENT DISPENSER HOSE
251213	INJECTOR S/S FOR DETERGENT IN
260408	S/S NUTS D.12
620242	DETERGENT INJECTOR (KIT)