

PARTI DI RICAMBIO
PIECES DETACHEES
SPARE PARTS
ERSATZTEILE
LISTA DE RECAMBIOS

FC 53 L BT
FC 53 C BT
FC 54 L BT
FC 54 C BT

9/96



01 - 2000 S. AG.

-
- 1 Hood
 - 2 Wash arm
 - 3 Rinse arm
 - 4 Tank
 - 5 Wash
 - 6 Rinse
 - 7 Pump
 - 8 Rinse aid injector
 - 9 Control box
 - 10 Drain pump
 - 11 Rinse booster pump
 - 12 Detergent dispenser

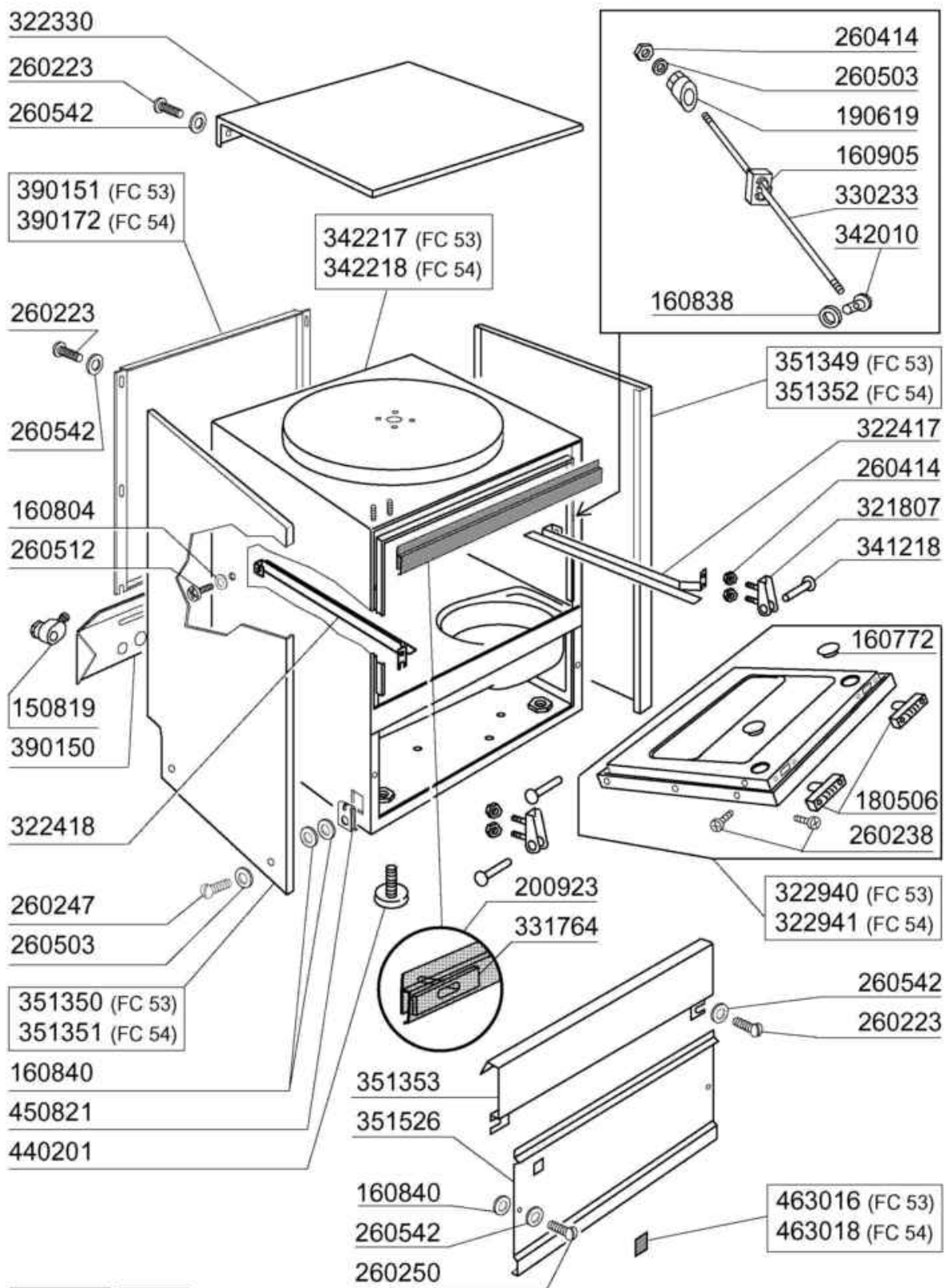

07 - 2001 S. AG.

Code	Description
150819	CABLE HOLDER PG16 WITH HOLE
160772	PLUG FOR DOOR (BR-BC-FC)
160804	GASKET D.6
160838	SLIDING WASHER TIE ROD FC
160840	WASHER
160905	SLIDING PLATE F. TIE ROD
180506	DOOR CATCH BR-BC-FC
190619	DOOR CATCH B-F-R
200923	DOOR GASKET
260223	M5X12 MSH/HD SCREW SPECIAL S/S
260238	M4 X 10 MUSH/HD SCREW
260247	SCREW TCB 5X16
260250	SCREW TB 5X20
260414	SELF-LOCKING NUT M5
260503	STAINL.STEEL FLAT WASHER D5 UN
260512	ST/ST GROWER WASHER D6
260542	WASHER D.5
321807	DOOR HINGE FC MACHINES
322330	COVER FC BT
322417	RIGHT GUIDE FC
322418	LEFT GUIDE FC
322940	DOOR FC53-FC53A
322941	DOOR FC54-543-544-HR
330233	FC DOOR TIE ROD
331764	FIXING PLATE FOR B-F DOOR GASK
341218	HINGE PIN B-F-G
342010	PIN FOR TIE ROD DOOR FC
342217	HOOD
342218	HOOD
351349	LATERAL PANEL FC53
351350	LATERAL PANEL FC53
351351	LEFT PANEL FC54-544-543-HR
351352	RIGHT PANEL FC54-543-544-HR
351353	FRONT PANEL FC
351526	LOWER FRONT PANEL
390150	LOWER BACK PANEL FC
390151	PANEL
390172	BACK PANEL
440201	RUBBER FOOT D.60X10
450821	SPRING CLIP FASTENER SNU 3634
463016	FC53 NAME
463018	FC54 NAME

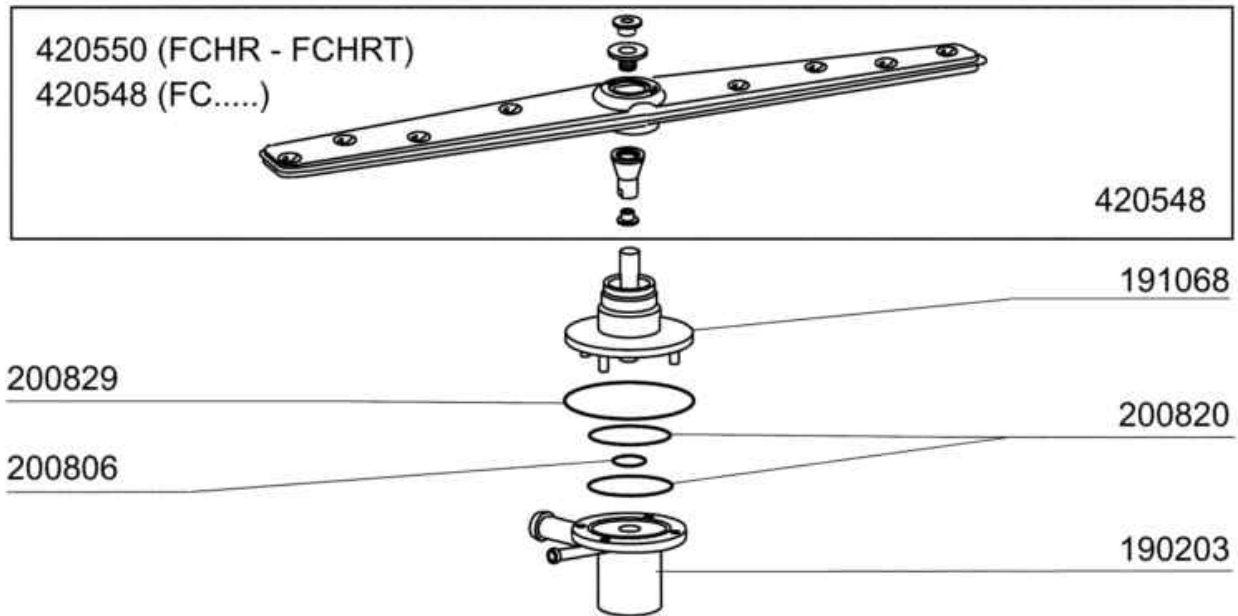
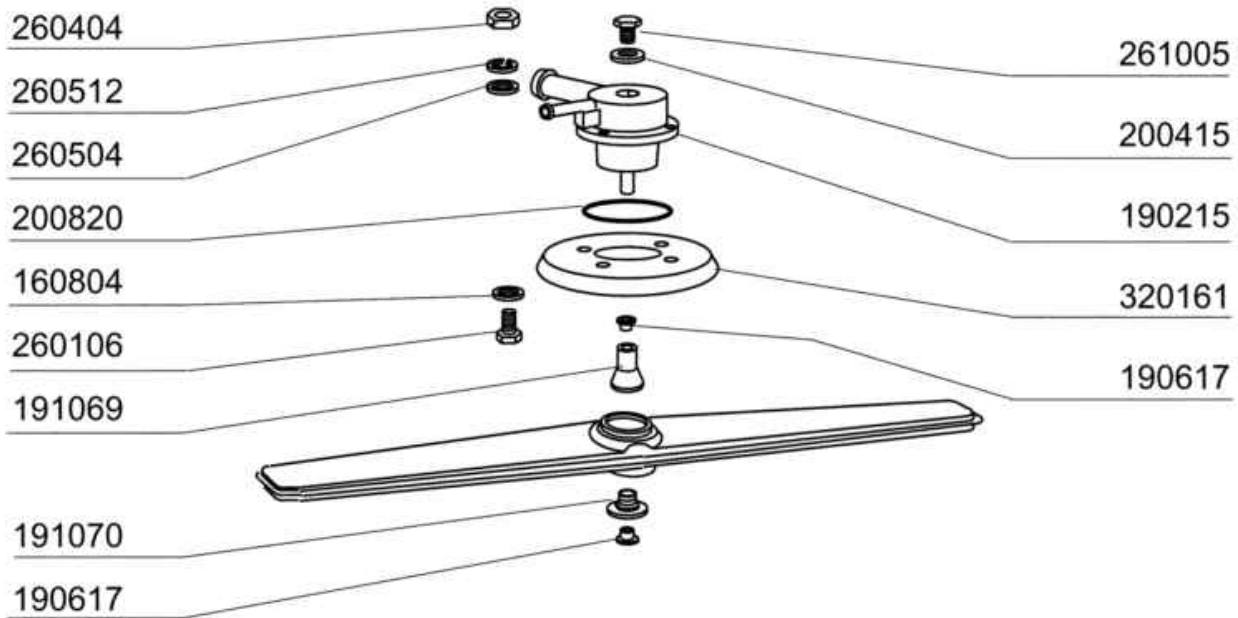

05 - 2000 S. AG.

Code	Description
160804	GASKET D.6
190203	LOWER TEE WASH-RINSE F2-45-55-
190215	UPPER WASH/RINSE ARM SUPPORT F
190617	BUSH
191068	LOWER WASH ARM SUPPORT FC-MACH
191069	WASH ARM CENTER (FC - MACHINES
191070	LOCK NUT FOR WASH ARM CENTER (
200415	AIR TRAP GASKET -F2 18,5X10X3
200806	O-RING 2,62X13,10X18,34
200820	O-RING151 46,99X5,33X57,6
200829	O-RING 81,92X92,58X5,33
260106	SCREW TE 6X25
260404	STAINLESS STEEL NUTS D6 UNI 55
260504	ST/ST FLAT WASHER D6
260512	ST/ST GROWER WASHER D6
261005	SCREW F. TEE UP.WASH F2-B41
320161	UPPER WASH ARM PROTECTION
420548	FC WASH ARM (ST/ST)
420550	WASH ARM FCHR - FCHRT

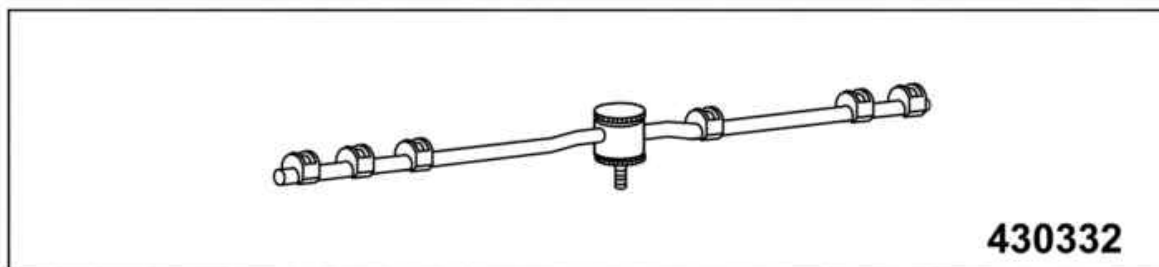
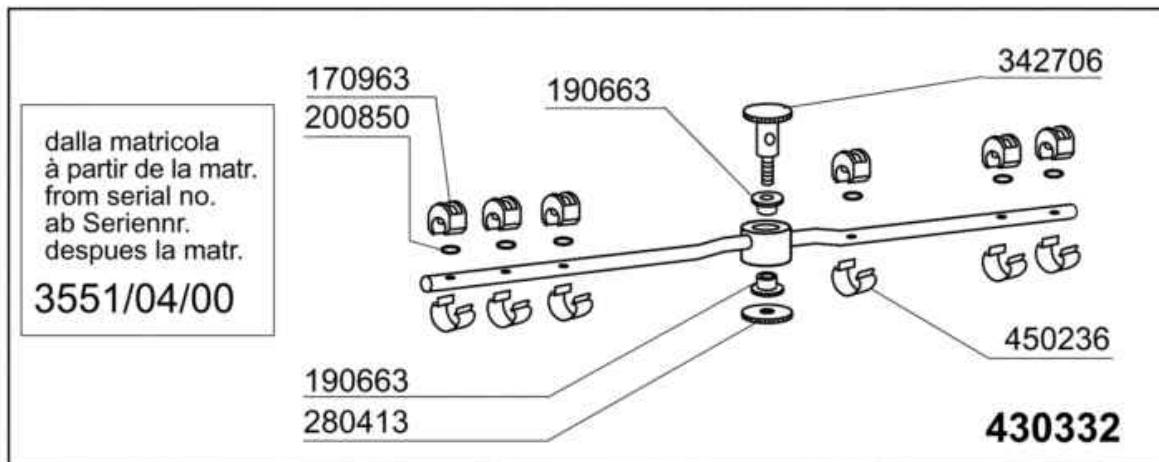
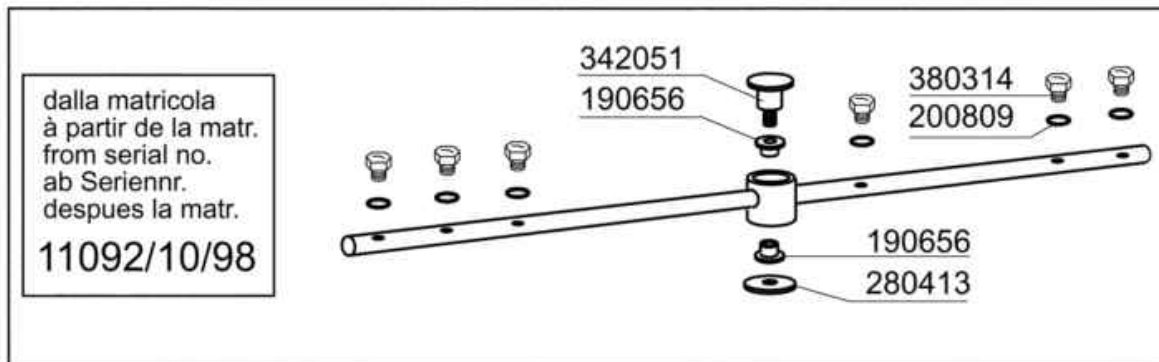
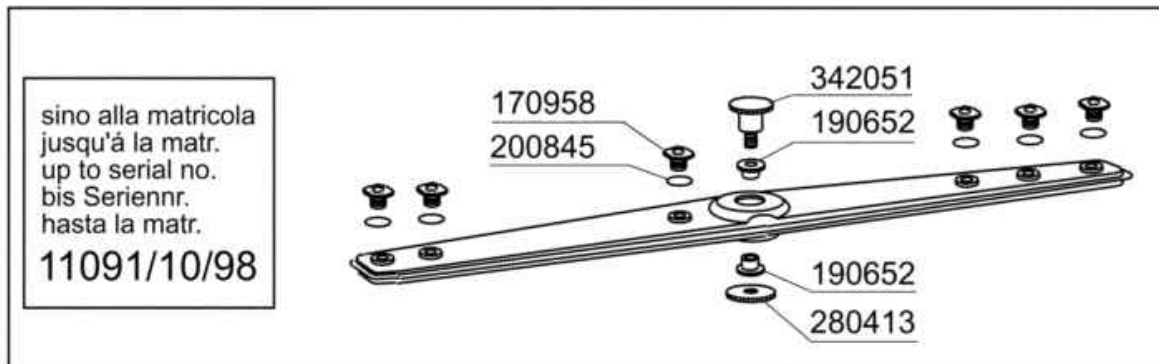

Code	Description
170958	RINSE JET FOR FC53-543
170963	RINSE JET X FC
190652	RINSE ARM BUSH FC
190656	BUSH RINSE ARM FC
190663	BUSH
200809	OR GASKET 1,78X8,73X12,29
200845	O RING 109 2,62X9,13X14,37
200850	O-RING
280413	RETAIN.LOCK NUT FOR FC RINSE A
342051	RINSE ARM SUPPORT FC
342706	SHAFT
380314	RINSE JETS 801/HR
430332	RINSE ARM FC 01/00
450236	SPRING FOR WASHER 170963

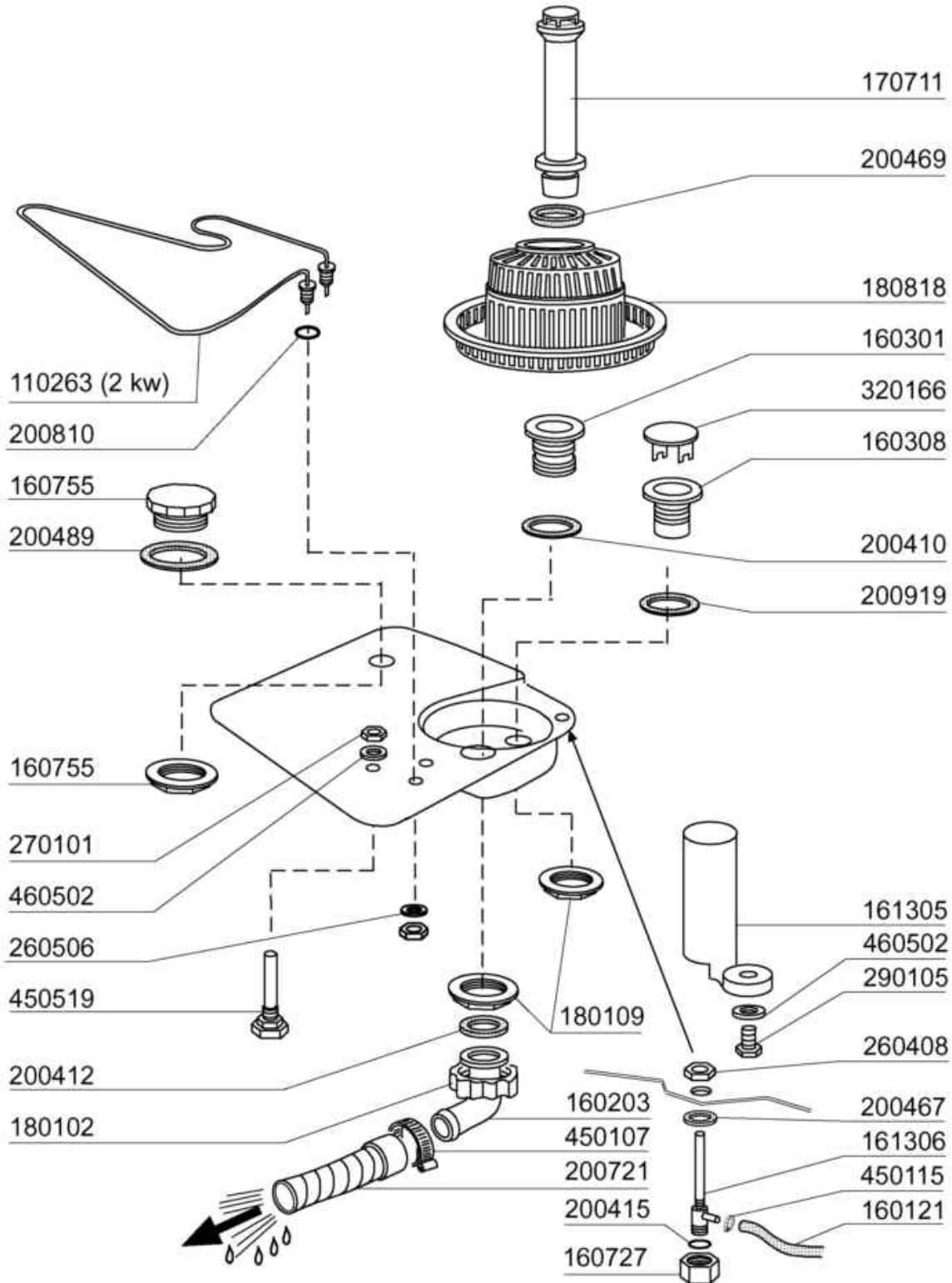

05 - 2002 | S. AG.

Code	Description
110263	TANK HEATER 2000W 230V
160121	HOSE EPDM D. 5 X 9
160203	ELBOW 1"1/2 N-S-F-C /DRAIN
160301	DRAIN OUTLET 1"1/2 C-S-N
160308	PUMP INLET HOSE FC
160727	PLUG 1/2 NTP CAP
160755	PLUG FOR MACHINES WITHOUT SOFT
161305	AIR CHAMBER F45-F80
161306	HOSE FOR AIR CHAMBER F45-80
170711	OVERFLOW PIPE FC
180102	DRAIN PIPE NUT 1"1/2 F45-55
180109	LOCK NUT 1 1/2"
180818	STRAINER FOR FC
200410	DRAIN OUTL.WASH.1 1/2"65X47X2
200412	GASKET DRAIN 1 1/2" 45X33X3
200415	AIR TRAP GASKET -F2 18,5X10X3
200467	DUTRAL GASKET F. AIR TRAP
200469	STAND PIPE O RING 45X35,5X7
200489	GASKET 81X68X3
200721	DRAIN HOSE 28X35 3MT.
200810	O-RING 2,62X9,92X15,6 F.GLASSW
200919	GASKET FOR SUCTION BASIN FC
260408	S/S NUTS D.12
260506	STAINL.STEEL FLAT WASHER D10
270101	HEXAGON LOCK NUT 1/2"
290105	BRASS-TE-PLUG 1/2"
320166	VORTEX BREAKER FOR FC MACHINES
450107	CLAMP FE ZN 38-50 H=12,2
450115	ELASTIC CLAMP D.8,3/7,8
450519	TANK THERMOSTAT SHIELD C-F
460502	GASKET 30X21X2

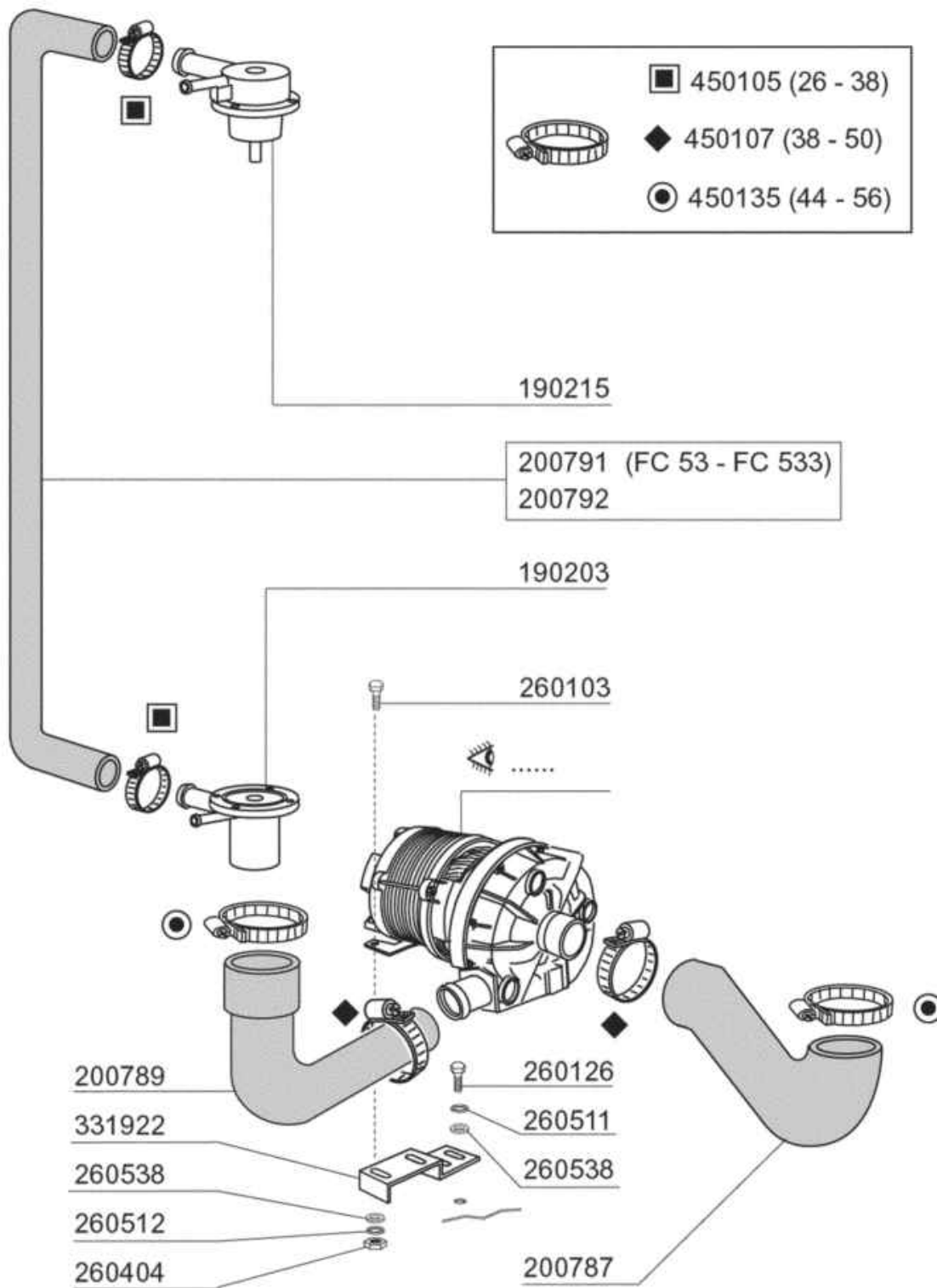

05 - 2001 S. AG.

Code	Description
190203	LOWER TEE WASH-RINSE F2-45-55-
190215	UPPER WASH/RINSE ARM SUPPORT F
200787	INLET HOSE FC53-FC544-FCHR
200789	OUTLET HOSE FC
200791	UPPER/LOWER WASH HOSE FC53
200792	HOSE FOR UPPER/LOWER WASH FC54
260103	SCREW TE 6X12
260126	SCREW TE 5X12
260404	STAINLESS STEEL NUTS D6 UNI 55
260511	GROWER WASHER D.5
260512	ST/ST GROWER WASHER D6
260538	WASHER 18X6X1,5 ST/ST
331922	BRACKET F. PUMP "F"
450105	CLAMP FE ZN. 26-38 H=12,2
450107	CLAMP FE ZN 38-50 H=12,2
450135	CLAMP FE ZN. 44-56 H=12,2

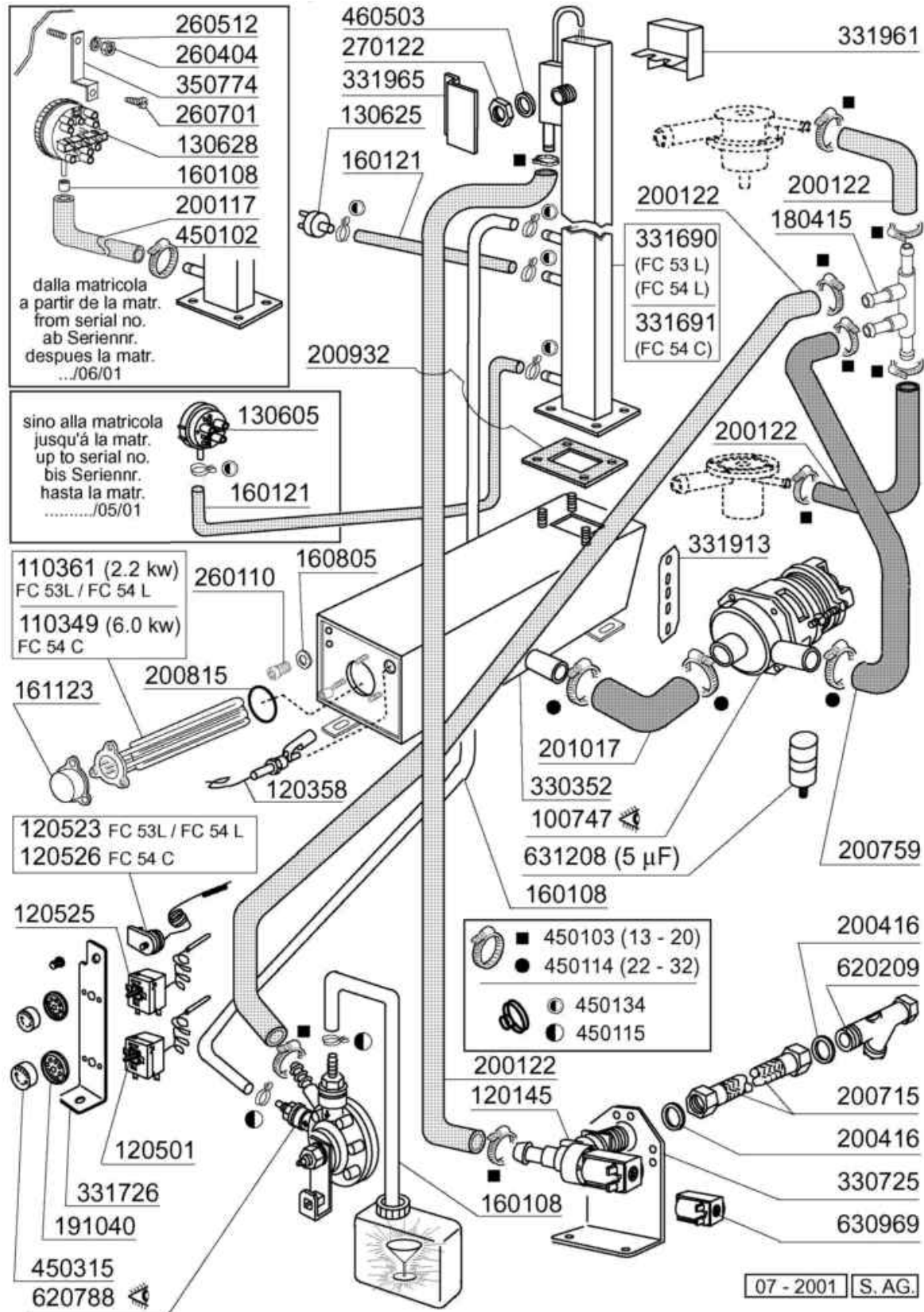

Code	Description
100747	PUMP KW 0,073 220/240-50 4208
110349	HEAT.ELEMENT 6000W 230/400V
110361	HEAT. ELEMENT 2200W 230V
120145	SOLENOID VALVE 12 LT 1 WAY
120358	FLOATING MAGN.SWITCH
120501	THERMOSTAT 30/90°C
120523	SAFETY THERMOSTAT 110?
120525	BOOSTER THERMOSTAT 2 TEMPERAT.
120526	SAFETY THERMOSTAT 2POLES
130605	PRESSURE SWITCH 50-30 1 LEVEL
130625	PRESSURE SWITCH
130628	PRESSURE SWITCH
160108	INJECT.INLET HOSE D.8X5
160121	HOSE EPDM D. 5 X 9
160805	GASKET D.8
161123	HEAT.ELEMENT COVER H42 SNL
180415	TEE NIPPLE DOUBLE "T"
191040	FRAME F.THERMOSTAT KNOB
200117	RUBBER HOSE 7X16
200122	HOSE 11X19
200416	GASKET D. 3/4"
200715	HOSE WATER INLET 2M STAINL.ST
200759	DELIVERY HOSE FOR ECORINSE AC-
200815	O-RING F. HEAT. ELEM.
200932	BOILER GASKET
201017	RINSE PUMP INLET HOSE LF/FC BT
260110	SCREW TE 8X10
260404	STAINLESS STEEL NUTS D6 UNI 55
260512	ST/ST GROWER WASHER D6
260701	SCREW 3,5X9,5
270122	NUTS D.3/4" FOR BREAK TANK
330352	BOILER FOR BREAK TANK
330725	STANDARD BRACKET F.SOLEN.VALV
331690	BREAK TANK FC53
331691	BREAK TANK FC54-LF
331726	BRACKET FOR 3 THERMOSTATS
331913	BRACKET
331961	NO-STEAM BRACKET FOR BREAK TAN
331965	BRACKET
350774	BRACKET
450102	CLAMP FE ZN 11-17 H=9
450103	CLAMP FE ZN. 13-20 H=9
450114	CLAMP FE ZN.22-32 H=12,2
450115	ELASTIC CLAMP D.8,3/7,8
450134	ELASTIC HOSE CLIP D.9,3/8,8

Code	Description
450315	KNOB F. THERMOSTAT 90?
460503	SEALING WASHER 38X27X2(3/4)
620209	INLET WATER FILTER
620788	RINSE AID INJECTOR H21428
630969	COIL S4216 220/50HZ
631208	CONDENSER 5MF.450V

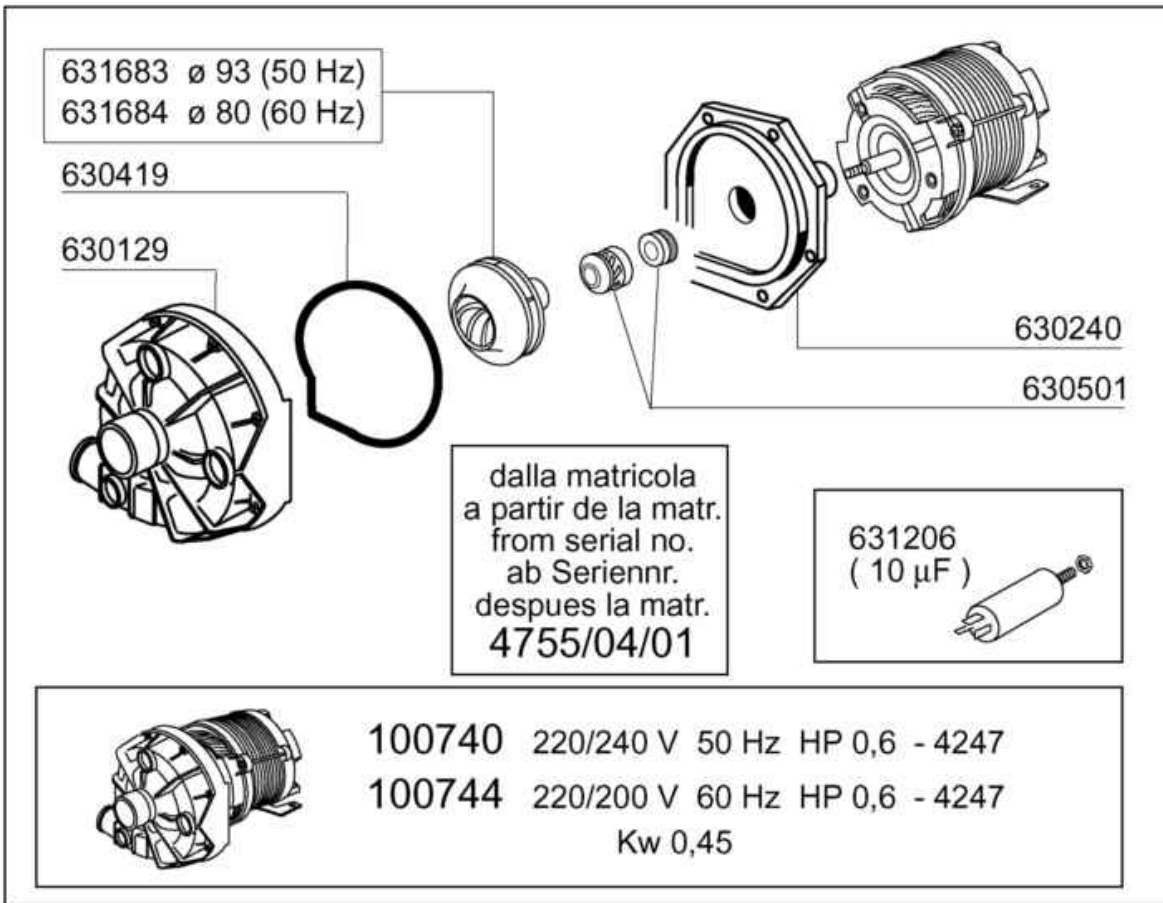
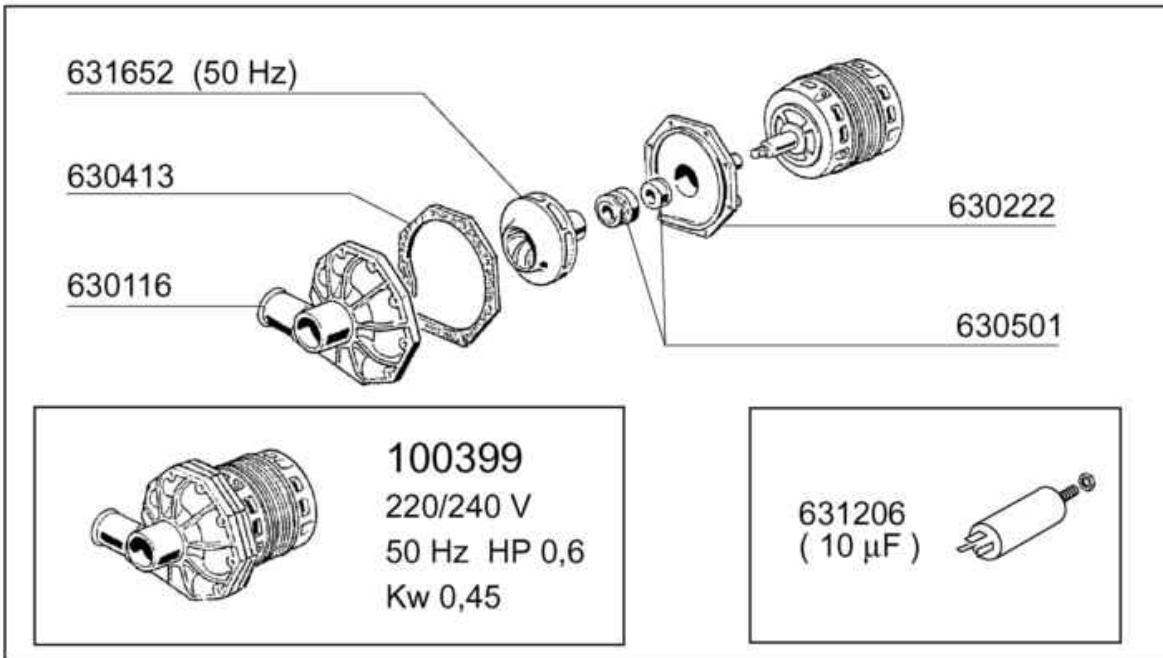

05 - 2001 | S.AG.

Code	Description
100399	PUMP HPO,6 220-50HZ (100740)
100740	PUMP 0,6HP 220/240V 4247
100744	PUMP HP 0,6 200-220-60HZ
630116	-NO MORE AVAILABLE
630129	VOLUTE PUMP 0,5HP 2247
630222	COVER PUMP IB HP 0,4
630240	PUMP FLANGE 0,6HP-4247 FIR
630413	-NO MORE AVAILABLE
630419	PUMP GASKET 2247 0,5HP
630501	SEAL FOR PUMP HP 2-3-3,2
631206	CONDENSER 10MF. 450V 85C
631652	-NO MORE AVAILABLE
631683	PUMP IMPELLER 50HZ FIR 4247
631684	IMPELLER FOR PUMP 60 HZ

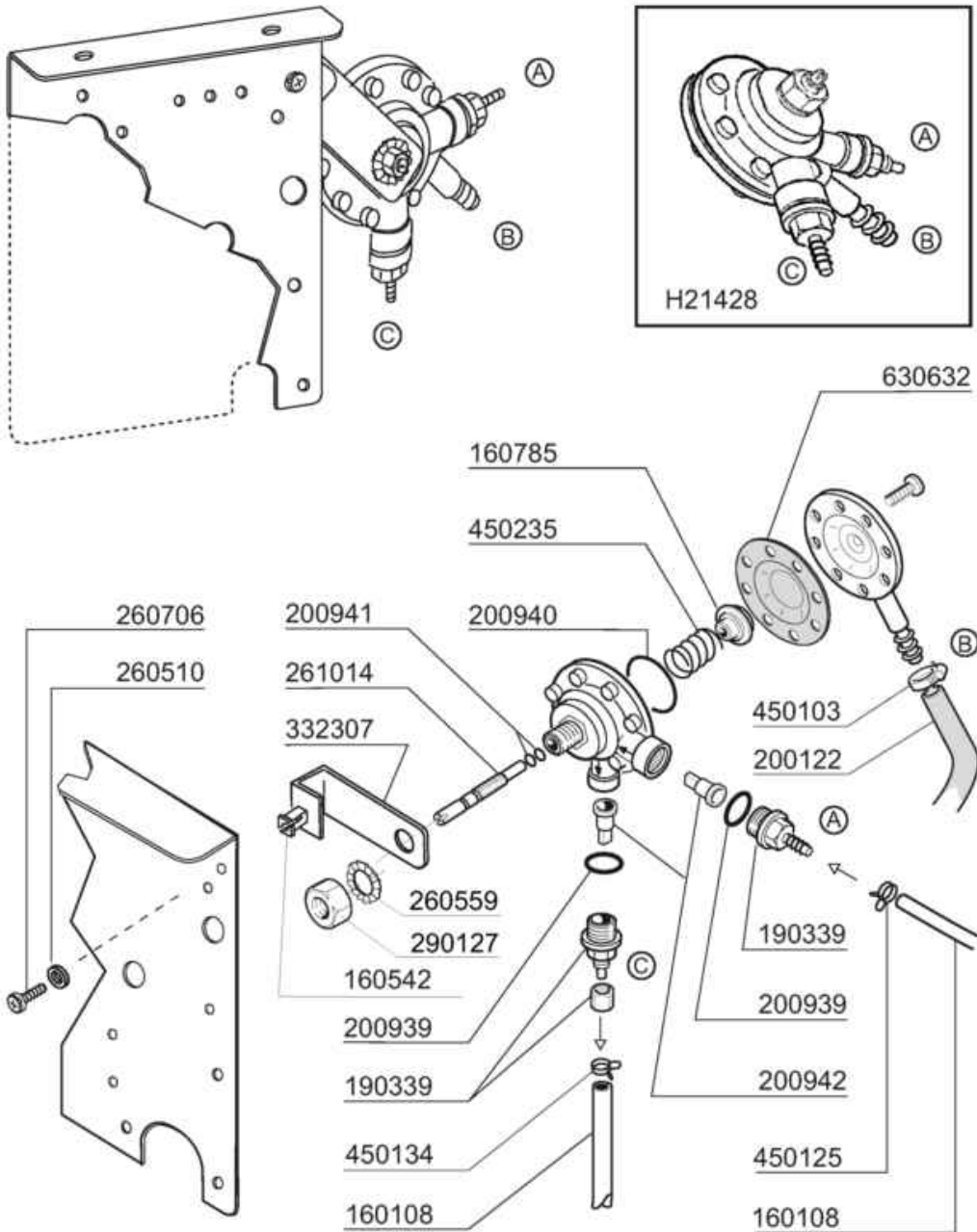

09-2015 MS

Rinse aid injector

Code	Description
160108	INJECT. INLET HOSE D.8X5
160542	SCREW SUPPORT
160785	GUIDE FOR SPRING RINSE AID INJ
190339	RINSE AID INJECTOR CONNECTION
200122	HOSE 11X19
200939	OR GASKET
200940	GASKET
200941	OR GASKET
200942	VALVE RINSE INJECTOR HVD
260510	GROWER WASHER D.4
260559	
260706	SCREW 3,9X13 S/S
261014	SCREW
290127	
332307	BRACKET
450103	CLAMP FE ZN. 13-20 H=9
450125	ELASTIC CLAMP D. 10,4X9,8
450134	ELASTIC HOSE CLIP D.9,3/8,8
450235	SPRING RINSE AID INJECTOR
630632	DIAPHRAGM RINSE INJECTOR HVD
H21428	RINSE AID INJECTOR

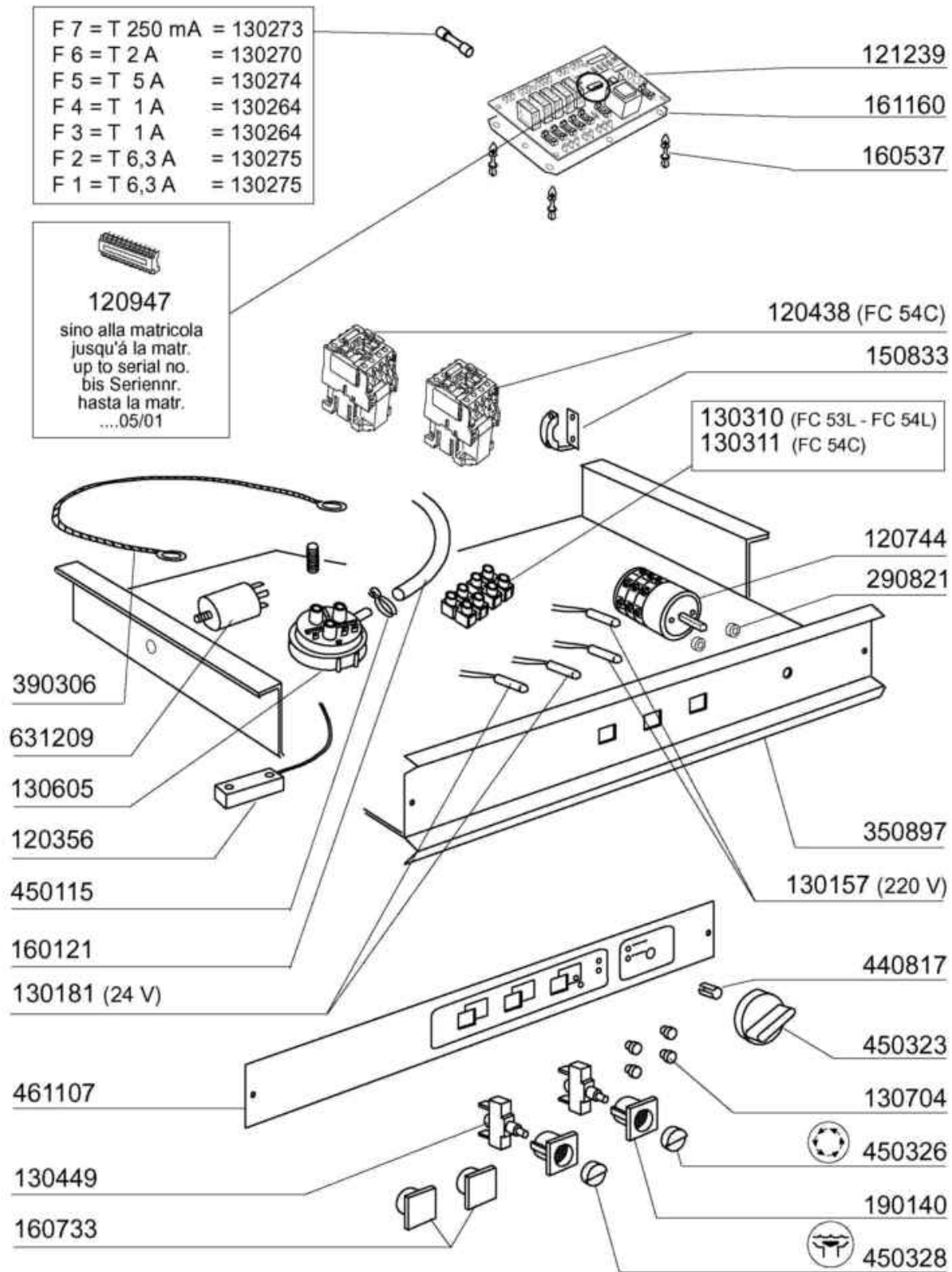

07 - 2001 S. AG. 01

Code	Description
120356	DOOR MAGN.SWITCH
120438	CONTACTOR 12A 220V 50HZ
120744	SWITCH QUADRIPOL.16A 380V
120947	EPROM UNICOM BT
121239	ELECTR.TIMER UNICOM FOR BREAK
130157	GREEN LED FOR BR-BC-C-SERIES -
130181	GREEN LAMP 24V
130264	FUSE 5X20 1A
130270	FUSE 5X20 2A
130273	FUSE 5X20 250MA GLAS
130274	FUSE 5X20 5A GLAS
130275	FUSE 5X20 6,3A GLAS
130310	TERMINAL BLOCK 3 POSITIONS
130311	TERMINAL BLOCK
130449	PUSH BUTTON BR-BC-FC
130605	PRESSURE SWITCH 50-30 1 LEVEL
130704	GREEN COLOUR.IND.LAMP COVER
150833	CABLE HOLDER BC/BR
160121	HOSE EPDM D. 5 X 9
160537	ELECTRONIC CARD SPACER
160733	BLANK PLATES
161160	PROTECTION ELECT.CARD C/F
190140	BUTTON HOLDER BR-BC-FC
290821	DISTANCE PIECE FOR SWITCH
350897	SUPPORT FOR CONTROL PANEL FC
390306	CABLE
440817	SNAP RING LSCB/1853/17/00
450115	ELASTIC CLAMP D.8,3/7,8
450323	KNOB FOR BC-BR-C95-C155
450326	PUSH BUTTON "CYCLE" GREEN
450328	DRAIN SWITCH
461107	PLATE FC53-54-543-544
631209	ANTI-NOISE FILTER

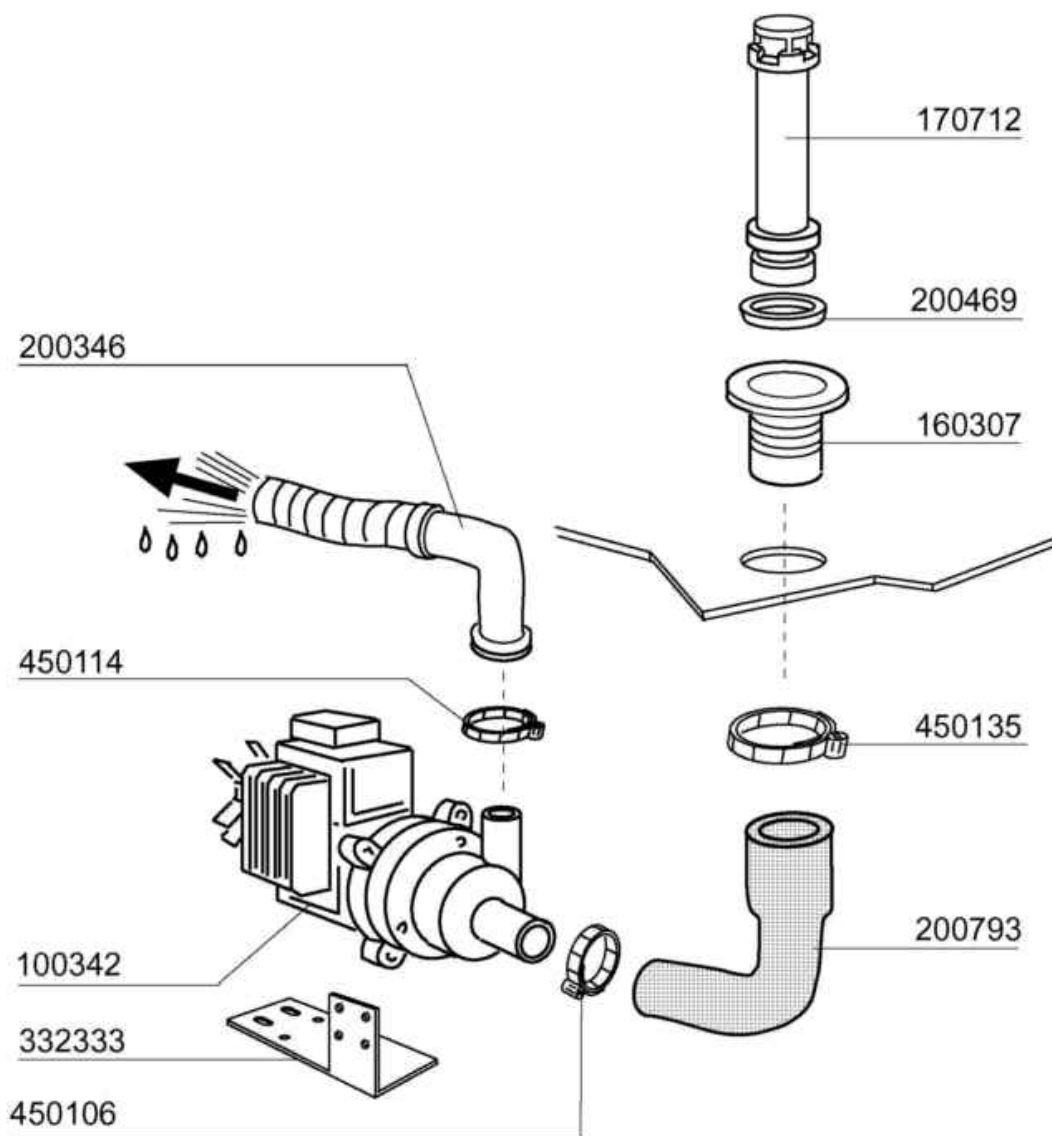
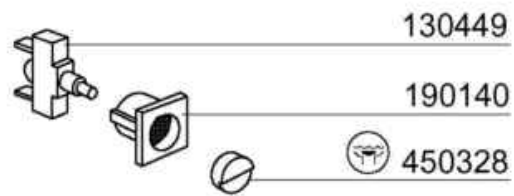

07 - 2001 | S. AG.

Code	Description
100342	DRAIN PUMP 100 W 220V
130449	PUSH BUTTON BR-BC-FC
160307	DRAIN OUTLET FC
170712	OVERFLOW PIPE FOR DRAIN PUMP
190140	BUTTON HOLDER BR-BC-FC
200346	DRAIN HOSE GLASSWASHER
200469	STAND PIPE O RING 45X35,5X7
200793	DRAIN PUMP INLET HOSE FC
332333	BRACKET FOR DRAIN PUMP
450106	CLAMP FE ZN 32-44 H=12,2
450114	CLAMP FE ZN.22-32 H=12,2
450135	CLAMP FE ZN. 44-56 H=12,2
450328	DRAIN SWITCH



100747 (220/240 V 50 Hz)
Kw 0,073

630416

631640 (50 Hz)

630131

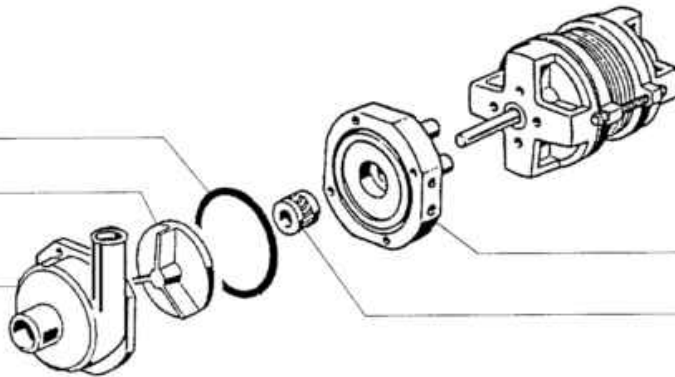

630242

630514

01 - 2000 S.A.G.

Rinse booster pump

Code	Description
100747	PUMP KW 0,073 220/240-50 4208
630131	VOLUTE PUMP FIR T.4208
630242	BACKPLATE FIR T.4208
630416	OR FOR VOLUTE 0,12/0,3
630514	PUMP SEAL FIR4208
631640	IMPELLER HP0,20/2212-8/5HZ

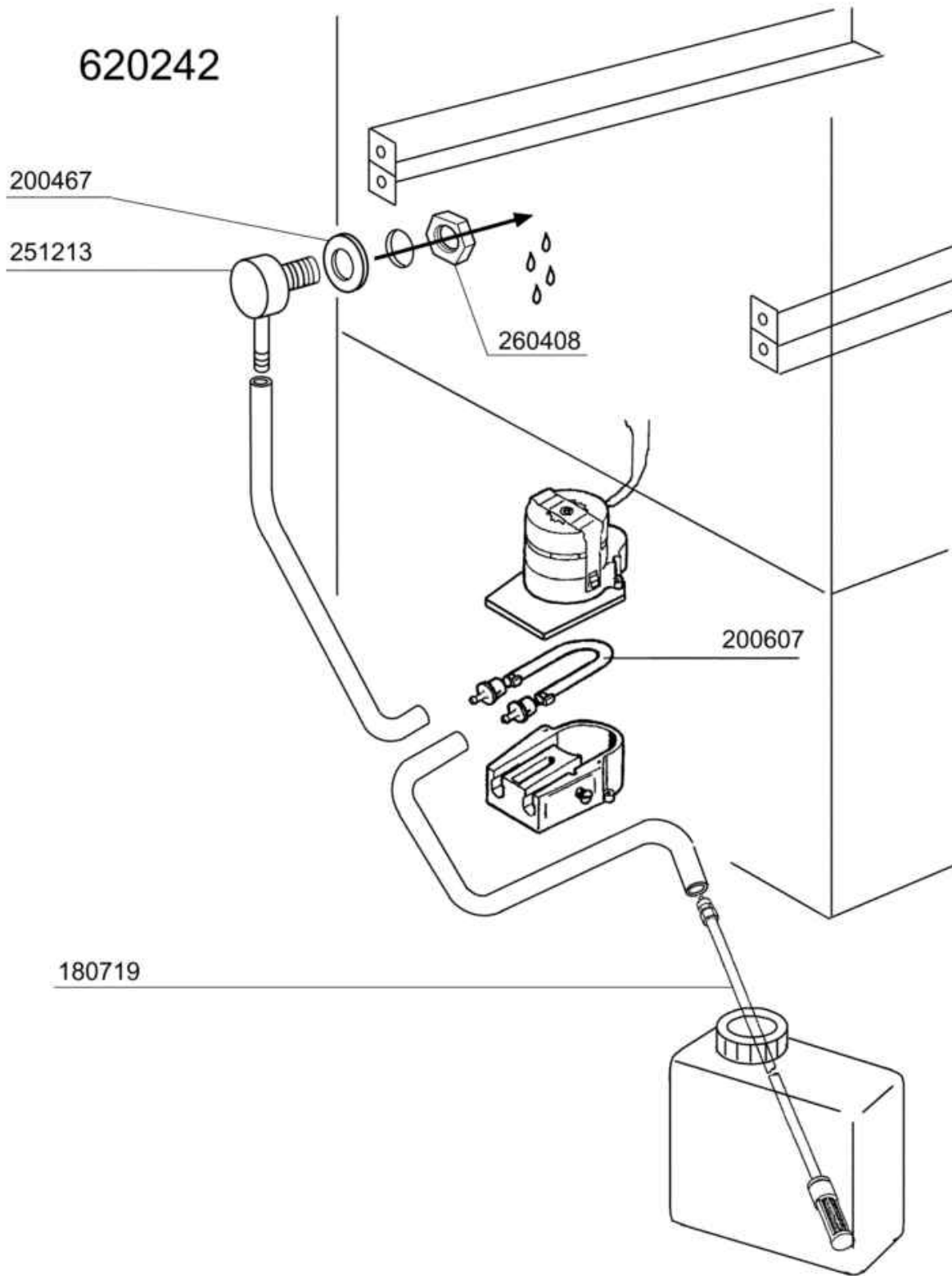

09 - 2000 S. AG.

Detergent dispenser

Code	Description
180719	DETERGENT DISPENSER SUCTION HO
200467	DUTRAL GASKET F. AIR TRAP
200607	DETERGENT DISPENSER HOSE
251213	INJECTOR S/S FOR DETERGENT IN
260408	S/S NUTS D.12
620242	DETERGENT INJECTOR (KIT)