

**F 45**

**F 55**

**F 65**

**F 80**

**PARTI DI RICAMBIO  
PIECES DETACHEES  
SPARE PARTS  
ERSATZTEILE  
LISTA DE RECAMBIOS**

- 1 Hood
- 2 Wash
- 3 Wash
- 4 Rinse assembly
- 5 Rinse assembly
- 6 Control Box F55- F65 - F80
- 7 Pump F80
- 8 Wash arm
- 9 Wash arm
- 10 Rinse aid injector

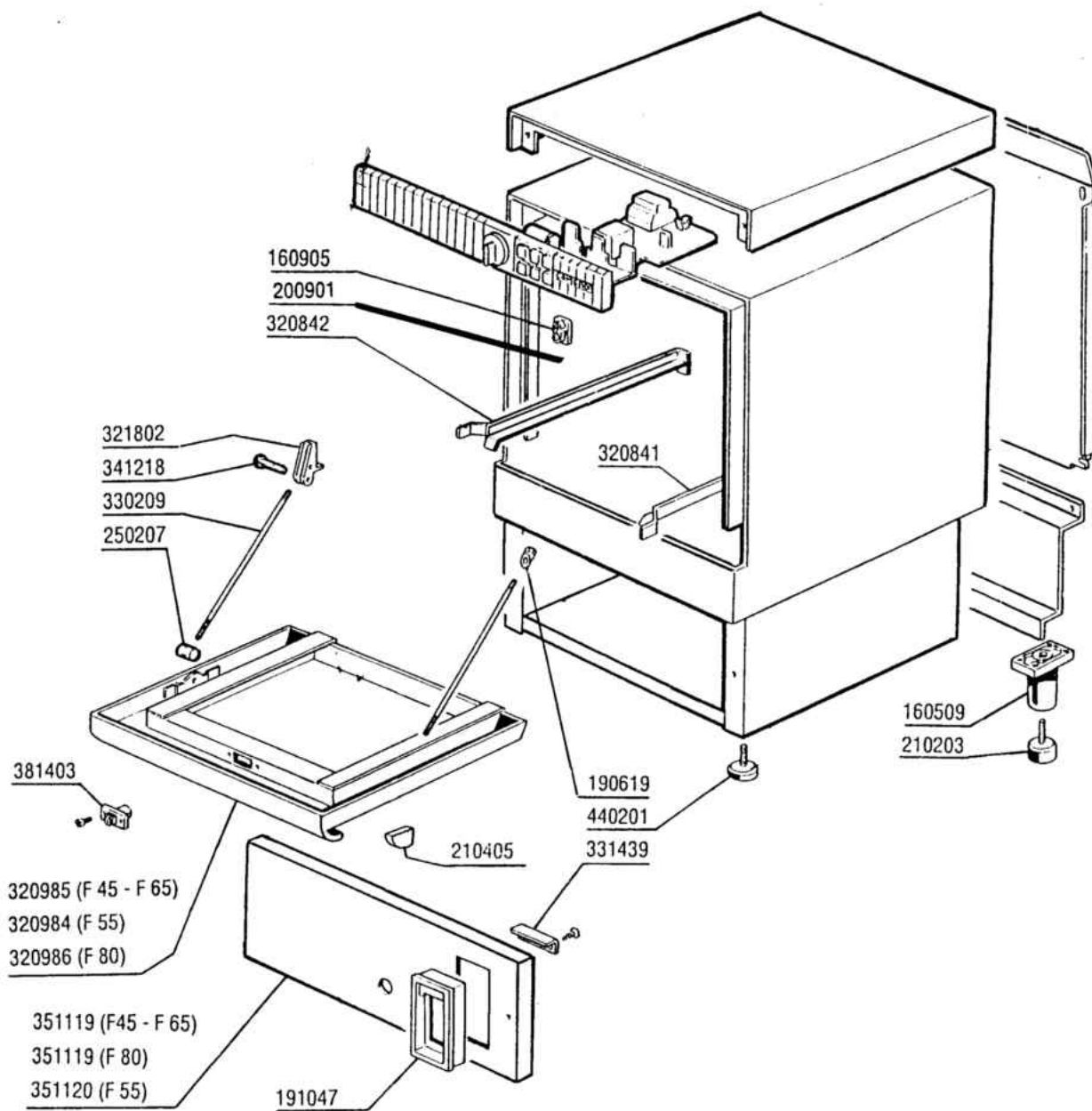

Code	Description
160509	FOOT SUPPORT
160905	SLIDING PLATE F. TIE ROD
190619	DOOR CATCH B-F-R
191047	RINSE AID FRAME F
200901	DOOR GASKET B-F
210203	RUBBER FOOT 30 MM
210405	PLUG FOR HANDLE
250207	SPEC.NUTS F.DOOR ROD AISI 303
320841	RIGHT GUIDE
320842	LEFT GUIDE
320984	DOOR F55
320985	DOOR F45-F65
320986	DOOR F80
321802	DOOR HINGE B-F
330209	TIE ROD 5MX305 F-45-55-65
331439	BRACKET FOR FRAME
341218	HINGE PIN B-F-G
351119	FRONT PANEL F45-F65-F80
351120	FRONT PANEL F55
381403	DOOR CATCH
440201	RUBBER FOOT D.60X10

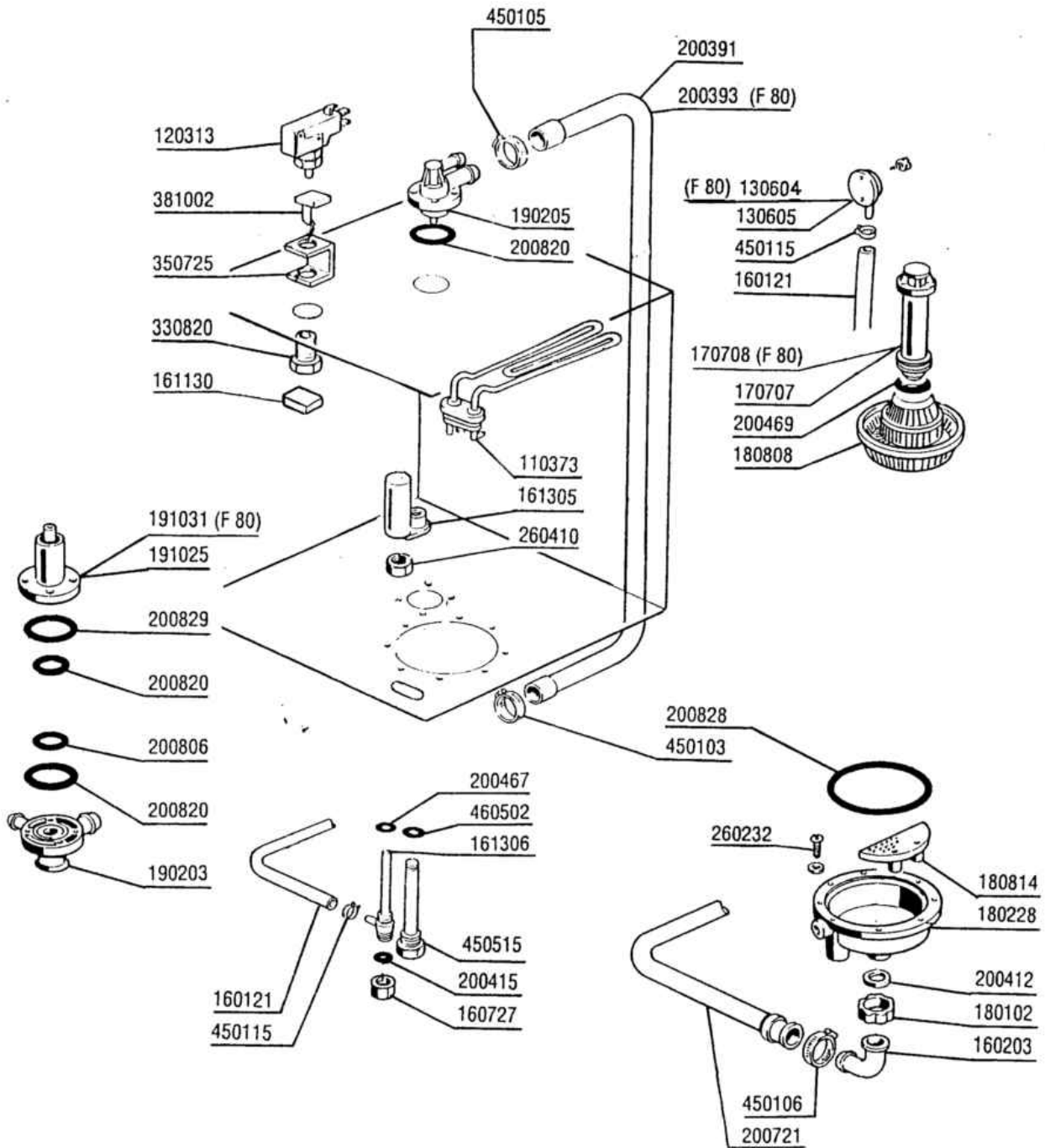

Code	Description
110373	HEAT.ELEMENT 2400W 230V
120313	DOOR MICROSWITCH
130604	PRESSURE SWITCH 80-50 1 LEVEL
130605	PRESSURE SWITCH 50-30 1 LEVEL
160121	HOSE EPDM D. 5 X 9
160203	ELBOW 1"1/2 N-S-F-C /DRAIN
160727	PLUG 1/2 NTP CAP
161130	DOOR MICRO SWITCH PROTECTION
161305	AIR CHAMBER F45-F80
161306	HOSE FOR AIR CHAMBER F45-80
170707	OVERFLOW PIPE H140-F2-45-55-R
170708	OVERFLOW PIPE H 215 X F3 C30-F
180102	DRAIN PIPE NUT 1"1/2 F45-55
180228	TANK SUCTION BASIN WITHOU.PRES
180808	STRAINER F2-45-55-80
180814	PROTECT.FILTER OF INLET PUMPE
190203	LOWER TEE WASH-RINSE F2-45-55-
190205	UPP.TEE WASH/RIN ARM F2-45-55-
191025	LOWER WASH ARM SUPP.B-F
191031	LOWER WASH ARM SUPPORT C30-F80
200391	WASH HOSE F2-45-55-65
200393	WASHING HOSE UPPER/LOWER F3-F8
200412	GASKET DRAIN 1 1/2" 45X33X3
200415	AIR TRAP GASKET -F2 18,5X10X3
200467	DUTRAL GASKET F. AIR TRAP
200469	STAND PIPE O RING 45X35,5X7
200721	DRAIN HOSE 28X35 3MT.
200806	O-RING 2,62X13,10X18,34
200820	O-RING151 46,99X5,33X57,6
200828	O-RING 183,75X190,81X3,53
200829	O-RING 81,92X92,58X5,33
260232	STAINL.ST TB SCREW 6X25 B15-6-
260410	NUT
330820	BUSH DOOR SWITCH F2-20-45-5
350725	MICRO BRACKET F300-45-55-65
381002	PIN F.DOOR MICRO F2-20-45-55
450103	CLAMP FE ZN. 13-20 H=9
450105	CLAMP FE ZN. 26-38 H=12,2
450106	CLAMP FE ZN 32-44 H=12,2
450115	ELASTIC CLAMP D.8,3/7,8
450515	STAINL.ST.SHIELD FOR 1 THERMOS
460502	GASKET 30X21X2

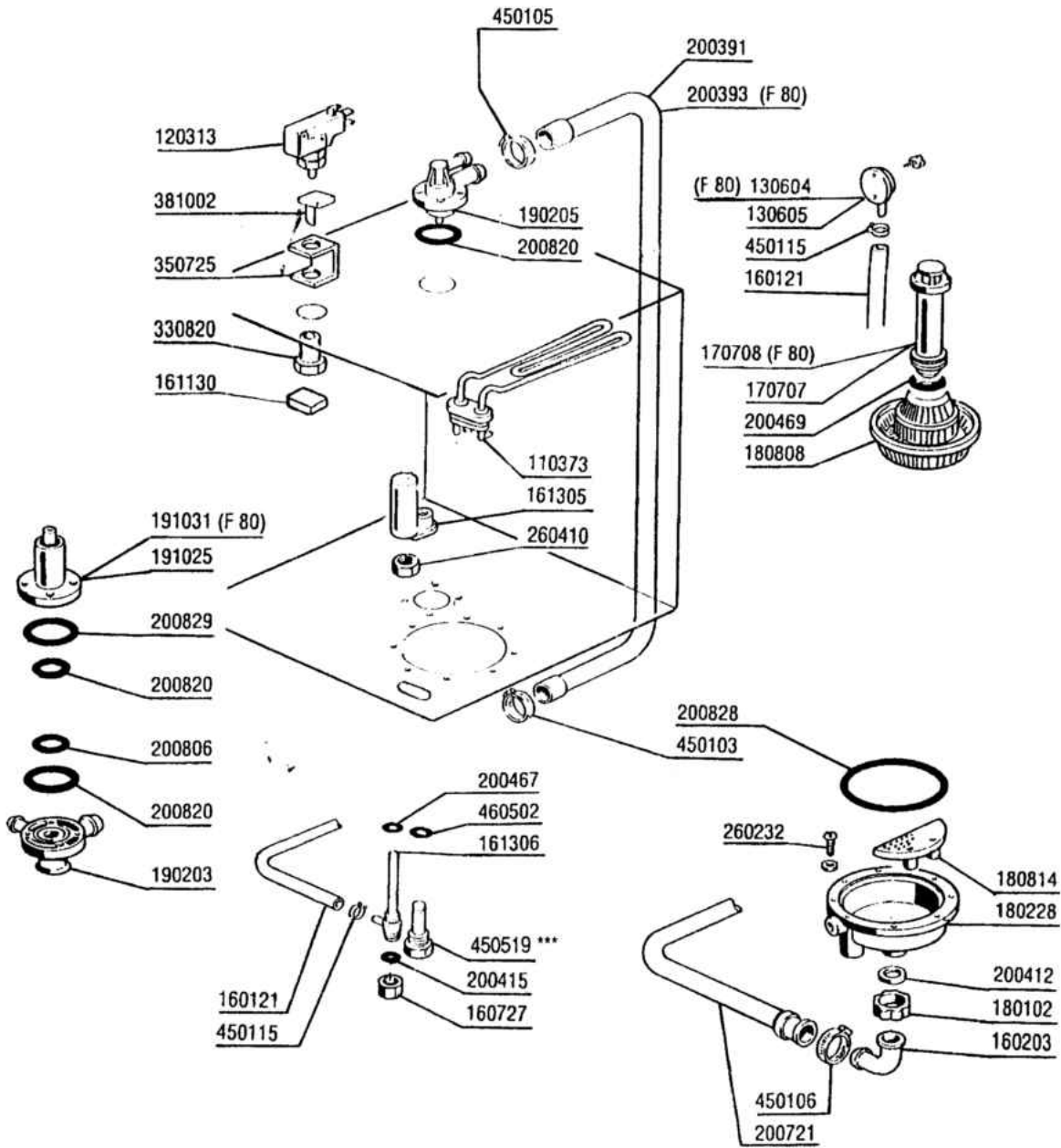

Code	Description
110373	HEAT.ELEMENT 2400W 230V
120313	DOOR MICROSWITCH
130604	PRESSURE SWITCH 80-50 1 LEVEL
130605	PRESSURE SWITCH 50-30 1 LEVEL
160121	HOSE EPDM D. 5 X 9
160203	ELBOW 1"1/2 N-S-F-C /DRAIN
160727	PLUG 1/2 NTP CAP
161130	DOOR MICRO SWITCH PROTECTION
161305	AIR CHAMBER F45-F80
161306	HOSE FOR AIR CHAMBER F45-80
170707	OVERFLOW PIPE H140-F2-45-55-R
170708	OVERFLOW PIPE H 215 X F3 C30-F
180102	DRAIN PIPE NUT 1"1/2 F45-55
180228	TANK SUCTION BASIN WITHOU.PRES
180808	STRAINER F2-45-55-80
180814	PROTECT.FILTER OF INLET PUMPE
190203	LOWER TEE WASH-RINSE F2-45-55-
190205	UPP.TEE WASH/RIN ARM F2-45-55-
191025	LOWER WASH ARM SUPP.B-F
191031	LOWER WASH ARM SUPPORT C30-F80
200391	WASH HOSE F2-45-55-65
200393	WASHING HOSE UPPER/LOWER F3-F8
200412	GASKET DRAIN 1 1/2" 45X33X3
200415	AIR TRAP GASKET -F2 18,5X10X3
200467	DUTRAL GASKET F. AIR TRAP
200469	STAND PIPE O RING 45X35,5X7
200721	DRAIN HOSE 28X35 3MT.
200806	O-RING 2,62X13,10X18,34
200820	O-RING151 46,99X5,33X57,6
200828	O-RING 183,75X190,81X3,53
200829	O-RING 81,92X92,58X5,33
260232	STAINL.ST TB SCREW 6X25 B15-6-
260410	NUT
330820	BUSH DOOR SWITCH F2-20-45-5
350725	MICRO BRACKET F300-45-55-65
381002	PIN F.DOOR MICRO F2-20-45-55
450103	CLAMP FE ZN. 13-20 H=9
450105	CLAMP FE ZN. 26-38 H=12,2
450106	CLAMP FE ZN 32-44 H=12,2
450115	ELASTIC CLAMP D.8,3/7,8
450519	TANK THERMOSTAT SHIELD C-F
460502	GASKET 30X21X2



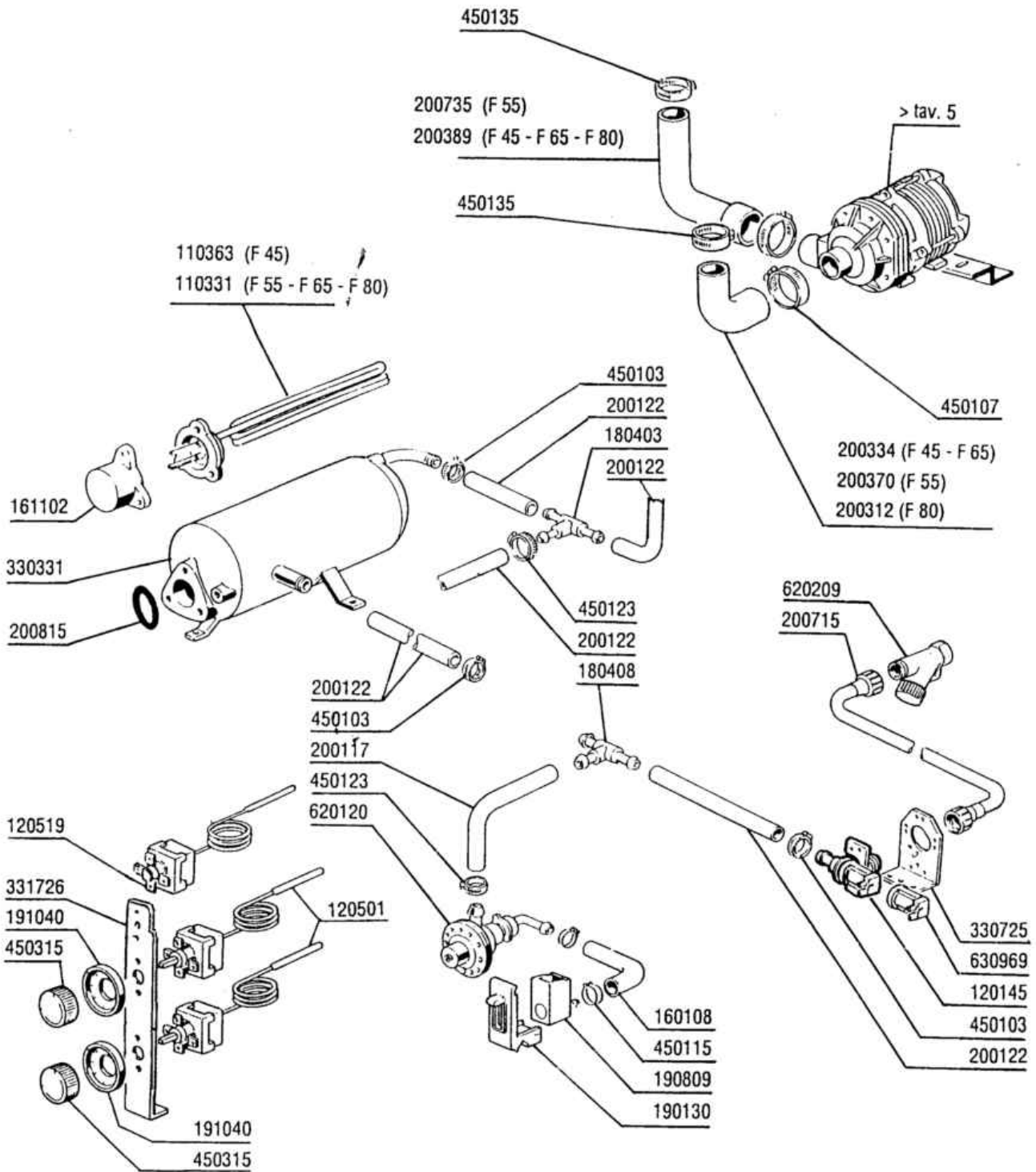

## Rinse assembly

Code	Description
110331	HEAT.ELEMENT 4200W 230/400V
110363	HEATING ELEMENT 3000W 230V
120145	SOLENOID VALVE 12 LT 1 WAY
120501	THERMOSTAT 30/90°C
120519	SAFETY THERMOSTAT 95-125°
160108	INJECT.INLET HOSE D.8X5
161102	ELEMENT COVER MOPL. H50 (HIGH)
180403	TEE-NIPPLE F2-F300-B10-11
180408	TEE-NIPPLE F.INJECT.W/CENTR.RE
190130	RINSE AID CONTAINER SUPPORT F
190809	RINSE AID CONTAINER B10-19-45
191040	FRAME F.THERMOSTAT KNOB
200117	RUBBER HOSE 7X16
200122	HOSE 11X19
200312	INLET HOSE F2 1?S F80
200334	INLET HOSE F45-65-F2
200370	PUMP INLET HOSE B41-F20-55
200389	OUTLET HOSE PUMP F2-45
200715	HOSE WATER INLET 2M STAINL.ST
200735	OUTLET HOSE PUMP F55
200815	O-RING F. HEAT. ELEM.
330331	BOOSTER (330342)
330725	STANDARD BRACKET F.SOLEN.VALV
331726	BRACKET FOR 3 THERMOSTATS
450103	CLAMP FE ZN. 13-20 H=9
450107	CLAMP FE ZN 38-50 H=12,2
450115	ELASTIC CLAMP D.8,3/7,8
450123	CLAMP FE ZN. 8-14 H=9
450135	CLAMP FE ZN. 44-56 H=12,2
450315	KNOB F. THERMOSTAT 90°
620120	RINSE AID INJECTOR
620209	INLET WATER FILTER
630969	COIL S4216 220/50HZ

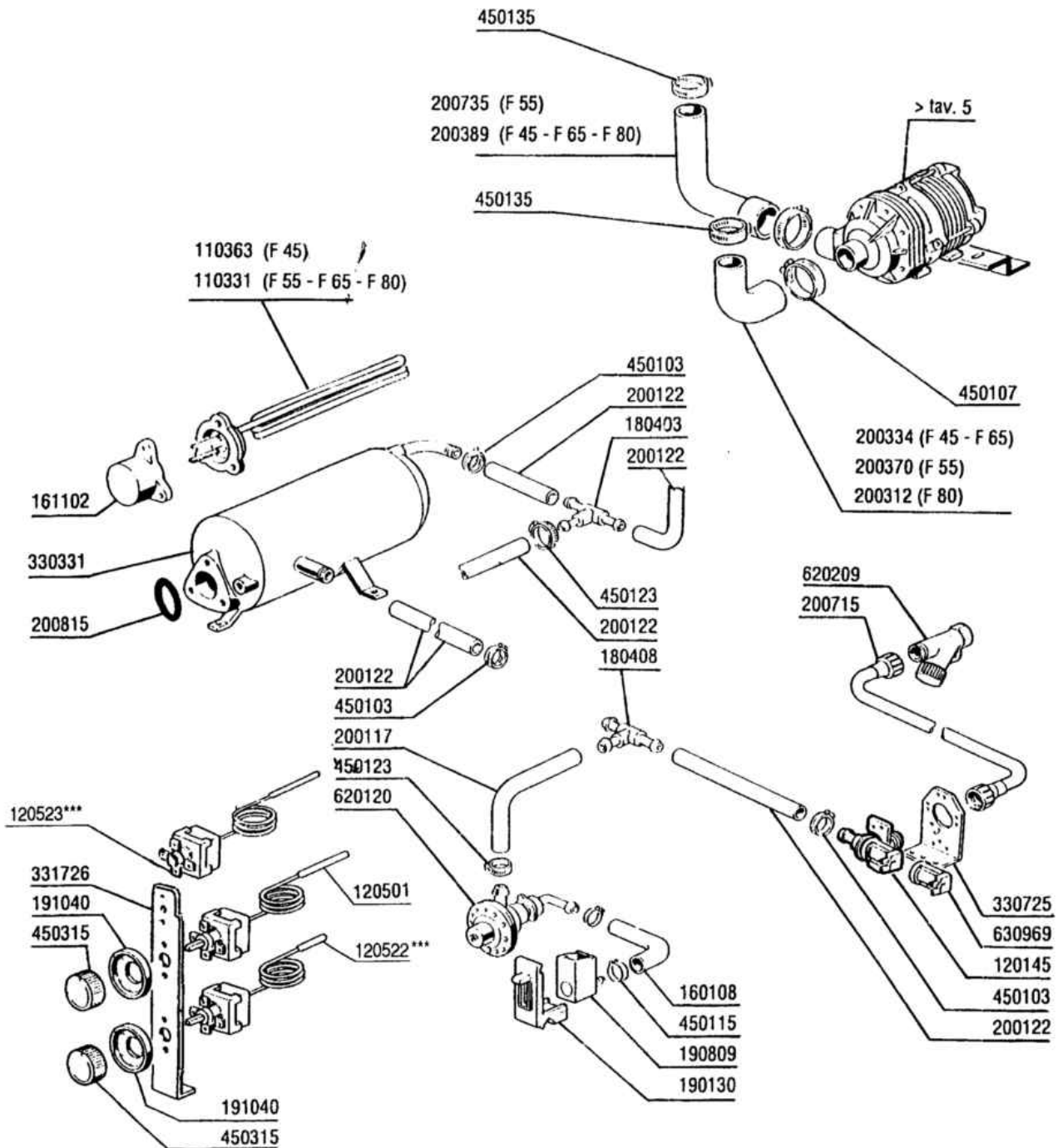

## Rinse assembly

Code	Description
110331	HEAT.ELEMENT 4200W 230/400V
110363	HEATING ELEMENT 3000W 230V
120145	SOLENOID VALVE 12 LT 1 WAY
120501	THERMOSTAT 30/90°C
120522	TANK THERMOSTAT 90°
120523	SAFETY THERMOSTAT 110°
160108	INJECT.INLET HOSE D.8X5
161102	ELEMENT COVER MOPL. H50 (HIGH)
180403	TEE-NIPPLE F2-F300-B10-11
180408	TEE-NIPPLE F.INJECT.W/CENTR.RE
190130	RINSE AID CONTAINER SUPPORT F
190809	RINSE AID CONTAINER B10-19-45
191040	FRAME F.THERMOSTAT KNOB
200117	RUBBER HOSE 7X16
200122	HOSE 11X19
200312	INLET HOSE F2 1?S F80
200334	INLET HOSE F45-65-F2
200370	PUMP INLET HOSE B41-F20-55
200389	OUTLET HOSE PUMP F2-45
200715	HOSE WATER INLET 2M STAINL.ST
200735	OUTLET HOSE PUMP F55
200815	O-RING F. HEAT. ELEM.
330331	BOOSTER (330342)
330725	STANDARD BRACKET F.SOLEN.VALV
331726	BRACKET FOR 3 THERMOSTATS
450103	CLAMP FE ZN. 13-20 H=9
450107	CLAMP FE ZN 38-50 H=12,2
450115	ELASTIC CLAMP D.8,3/7,8
450123	CLAMP FE ZN. 8-14 H=9
450135	CLAMP FE ZN. 44-56 H=12,2
450315	KNOB F. THERMOSTAT 90°
620120	RINSE AID INJECTOR
620209	INLET WATER FILTER
630969	COIL S4216 220/50HZ

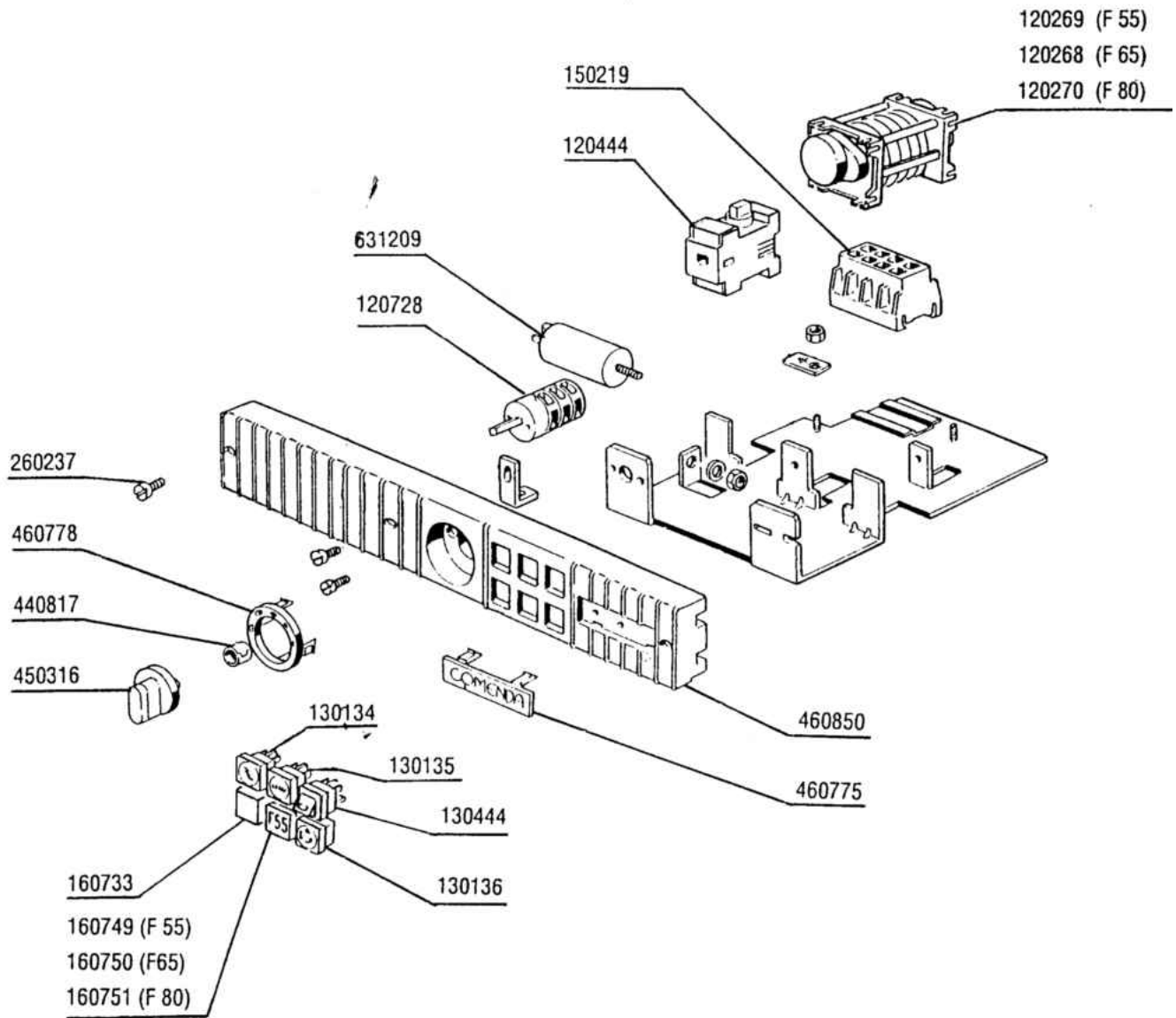

## Control Box F55- F65 - F80

Code	Description
120268	TWIN MOTOR TIMER 100/150"
120269	TWIN MOTOR TIMER 120/180"
120270	TWIN MOTOR TIMER 75/120"
120444	CONTACTOR 9A 220V 50HZ
120728	8 POLE SWITCH 16A 4 POSITIONS
130134	PILOT LAMP 220V
130135	PILOT LAMP: MACHINE READY B10>
130136	PILOT LAMP WORKING MACHINE
130444	SWITCH "START CYCLE" F
150219	TERMINAL BLOCK 5P MMQ165VD26
160733	BLANK PLATES
160749	PLUG
160750	PLUG WITH SYMBOL F65
160751	PLUG
260237	SCREW TCP 5X25 BLACK
440817	SNAP RING LSCB/1853/17/00
450316	CONTROL KNOB TWO COLOURS B-BT-
460775	LABEL (460817)
460778	SWITCH PLATES F55-65-80 4 SYM
460850	PLATE F45-80
631209	ANTI-NOISE FILTER

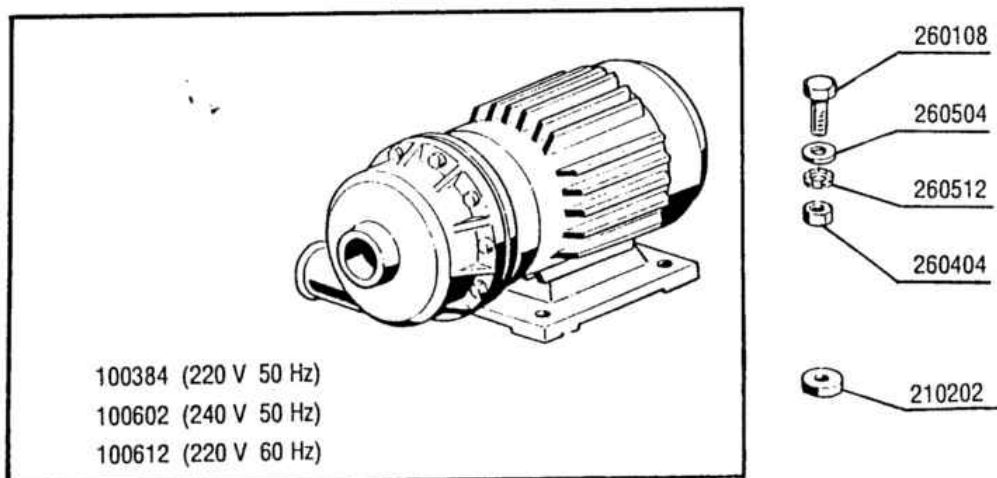
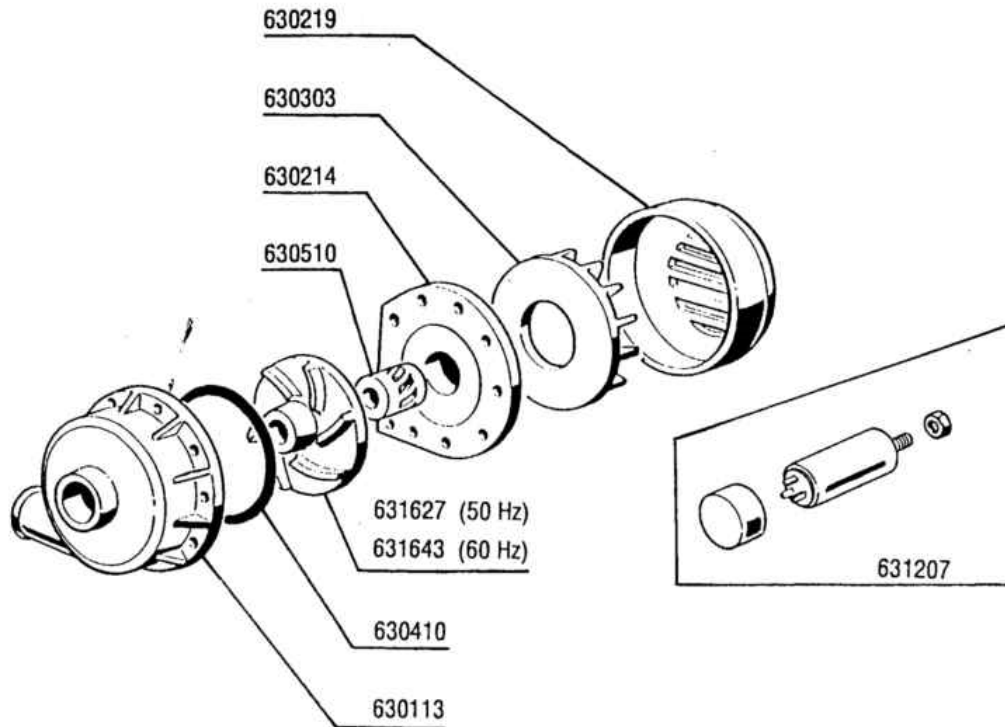

Code	Description
100384	PUMP HP 1 240/1-50HZ-1219 1219
100602	PUMP HP 1 240V 50 HZ FI 1219
100612	PUMP HP 1 220/1/60HZ F 1219
210202	RUBBER FOOT GLASSWASHER
260108	SCREW TE 6X40
260404	STAINLESS STEEL NUTS D6 UNI 55
260504	ST/ST FLAT WASHER D6
260512	ST/ST GROWER WASHER D6
630113	VOLUTE FIR HP0,5-1,55
630214	FLANGE PUMP HP0,75-1-1,5
630219	FAN HOUSING FIR HP.0,75-1
630303	FAN IMPELL.OF PUMP HP 0,5-0,7
630410	O-RING PUMP FI HP0,5-0,75-1
630510	PUMP SEAL HP0,5-0,75
631207	CONDENSER 12,5MF. 450V 85C
631627	PUMP IMPELLER FI D103 HP 1-1,5
631643	IMPELLER HP1/1,5 60HZD.90-1219



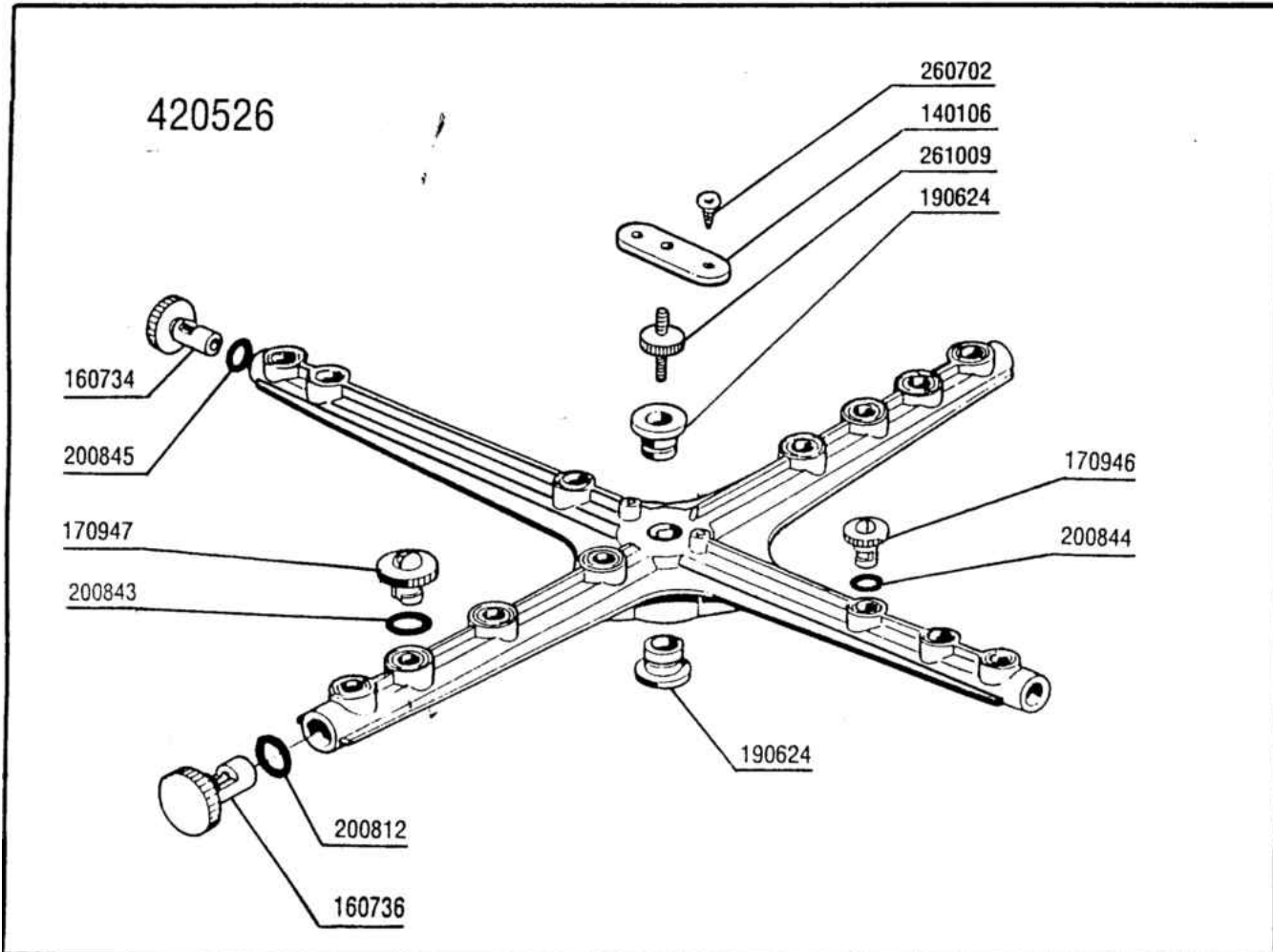

Code	Description
140106	PLATE F.CLAMP SCREW/WASH-RINSE
160734	END PLUGS RINSE ARM
160736	WASH ARM PLUG F45
170946	RINSE JET/RINSE ARM B-F
170947	WASH JET/WASH ARM F45-80
190624	BUSH FOR PLASTIC ARM F45
200812	O-RING 1,78X17,17X20,73
200843	O RING 2X13X17
200844	O RING 2X9,5X13,5
200845	O RING 109 2,62X9,13X14,37
260702	SELF-TAPPING SCREW 4,2X9,5 DIN
261009	RETAIN.SCREW FOR WASH-RINSE AR
420526	PLASTIC WASH-RINSE ARM (F45)

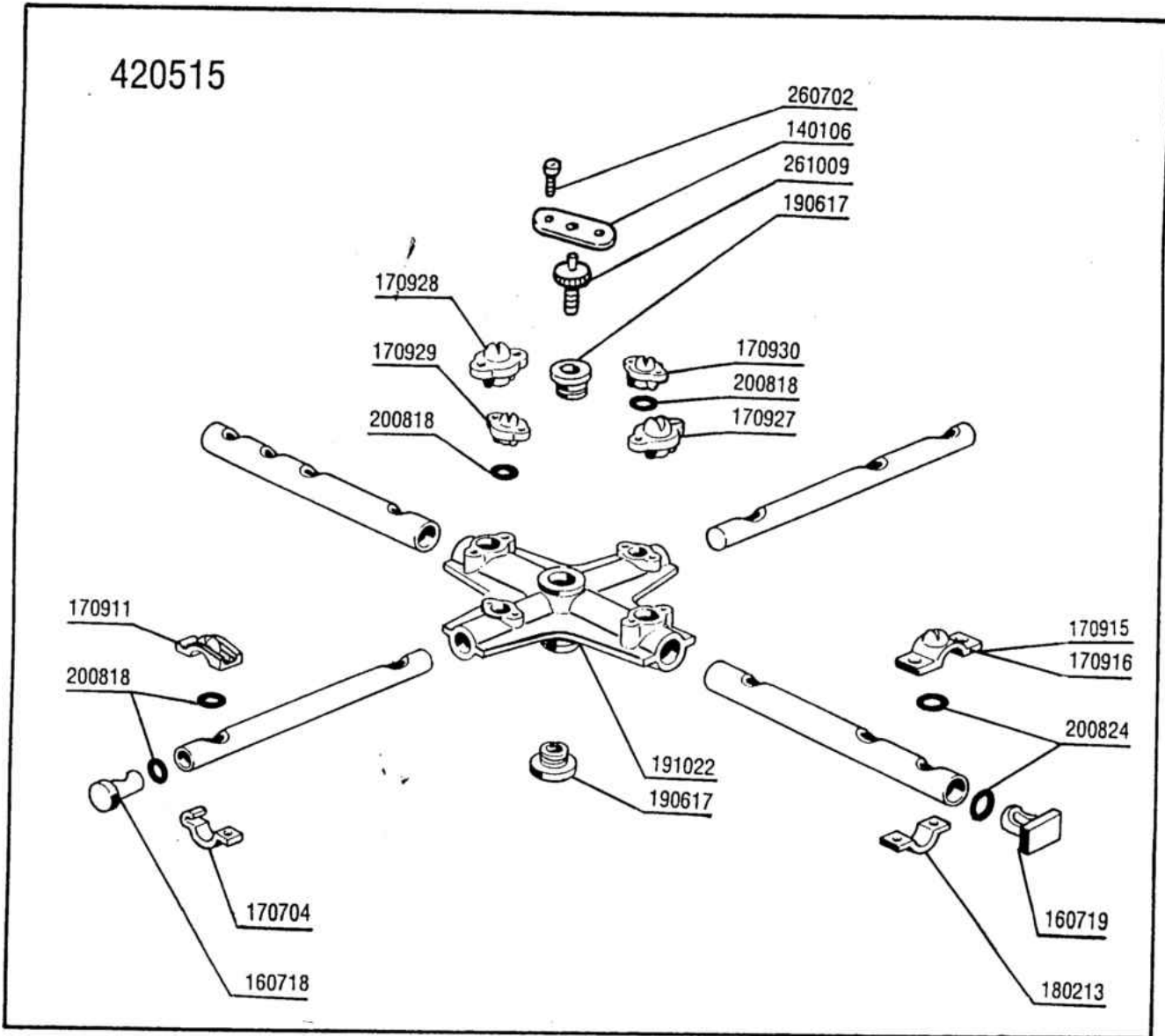

Code	Description
140106	PLATE F.CLAMP SCREW/WASH-RINSE
160718	PLUG F. RINSE ARM F2-C34M
160719	PLUG FOR WASH ARM D.18
170704	RINSE NOZZLE BOTTOM F-B-C33
170911	RINSE JET B23-F2-C34
170915	RIGHT JET B-F
170916	LEFT JET B-F
170927	WASH JET F2-C-GRAY
170928	IDLE JET F2-C-GRAY
170929	RINSE JET F2-C-GRAY
170930	IDLE JET F2-C-GRAY
180213	FLANGE F.JET LOCKING F2-C34
190617	BUSH
191022	WASH ARM CENTRAL CROSS F-B
200818	O-RING 1,78 X 6,75 X 10,31
200824	O-RING 1,78X12,42X15,98
260702	SELF-TAPPING SCREW 4,2X9,5 DIN
261009	RETAIN.SCREW FOR WASH-RINSE AR
420515	WASH-RINSE ARM F45-C85

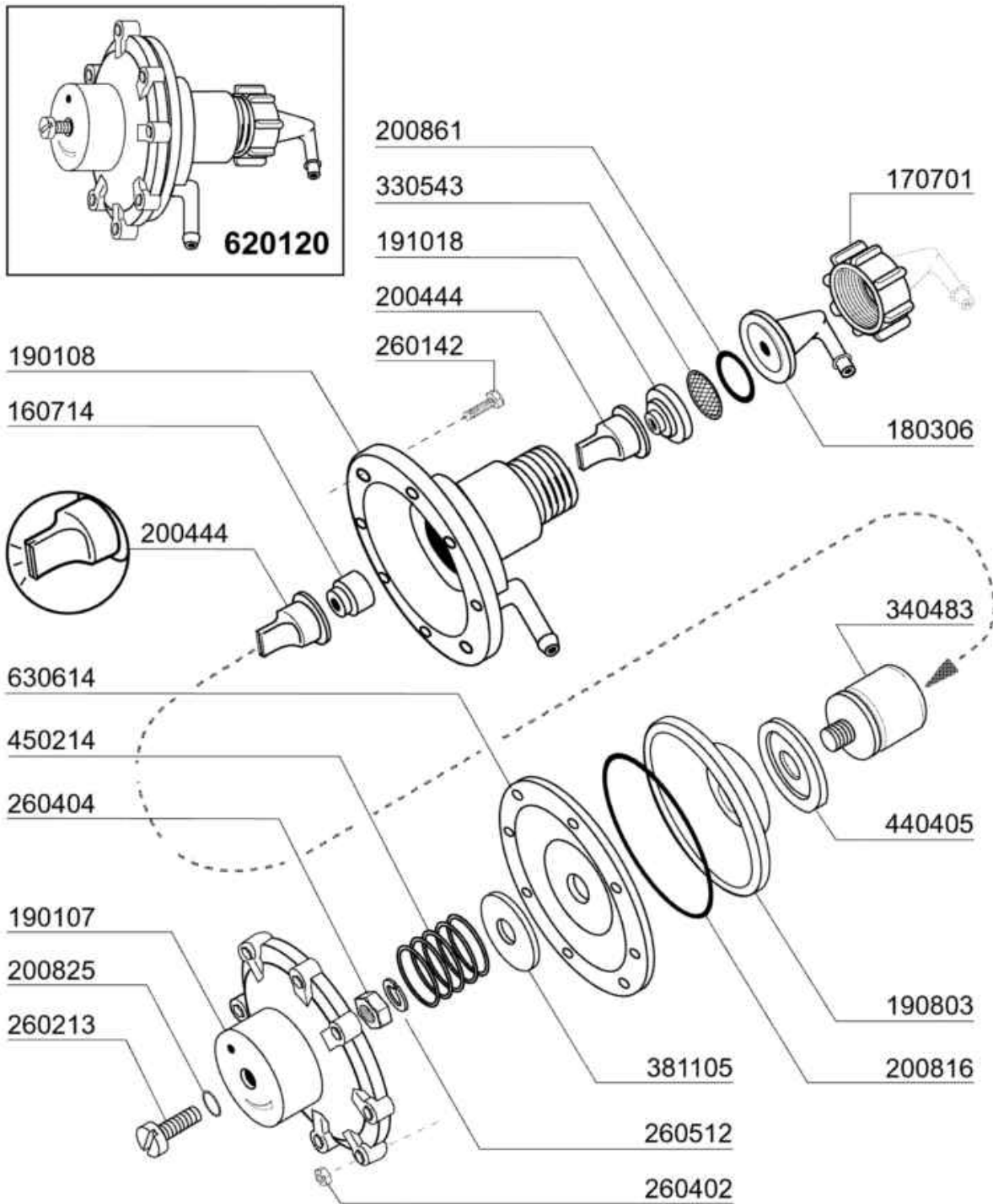

02 - 2004 | S. AG.

## Rinse aid injector

Code	Description
160714	PLUG FOR RINSE AID INJECTOR MO
170701	LOCK NUT 1/2" F.INJECTOR
180306	NIPPLE F.RINSE AID INJECTOR
190107	COVER FOR RINSE AID DISPENSER
190108	VOLUTE FOR RINSE AID DISPENSER
190803	GASKET SUPPORT RING F.INJECT
191018	FILTER SUPPORT RINSE AID INJEC
200444	SUCTION VALVE RINSE INJECTOR
200816	O-RING 2,5X59,2X64,2 RINSE INJ
200825	O-RING 3X5X11 RINSE INJECTOR
200861	O-RING 14X18X2
260142	SCREW TE 4X16
260213	SCREW TCP 5X25
260402	STAINLESS STEEL NUT D4 UNI 55
260404	STAINLESS STEEL NUTS D6 UNI 55
260512	ST/ST GROWER WASHER D6
330543	FILTER RINSE AID INJECTOR D.17
340483	PISTON FOR RINSE AID DISPENSER
381105	DIAPHRAGME DISC
440405	GASKET FOR RINSE AID INJ.
450214	SPRING RINSE AID INJECTOR
620120	RINSE AID INJECTOR
630614	DIAPHRAGM RINSE INJECTOR