



*C 80*

# LIST OF THE EXPLODED VIEWS



*SHELL ASSY*

*COOLING SYSTEM*

*HYDRAULIC CIRCUIT*

*ELECTRIC PARTS*

Rev. 10 - 21/06/2011



# C 80

# SHELL ASSY

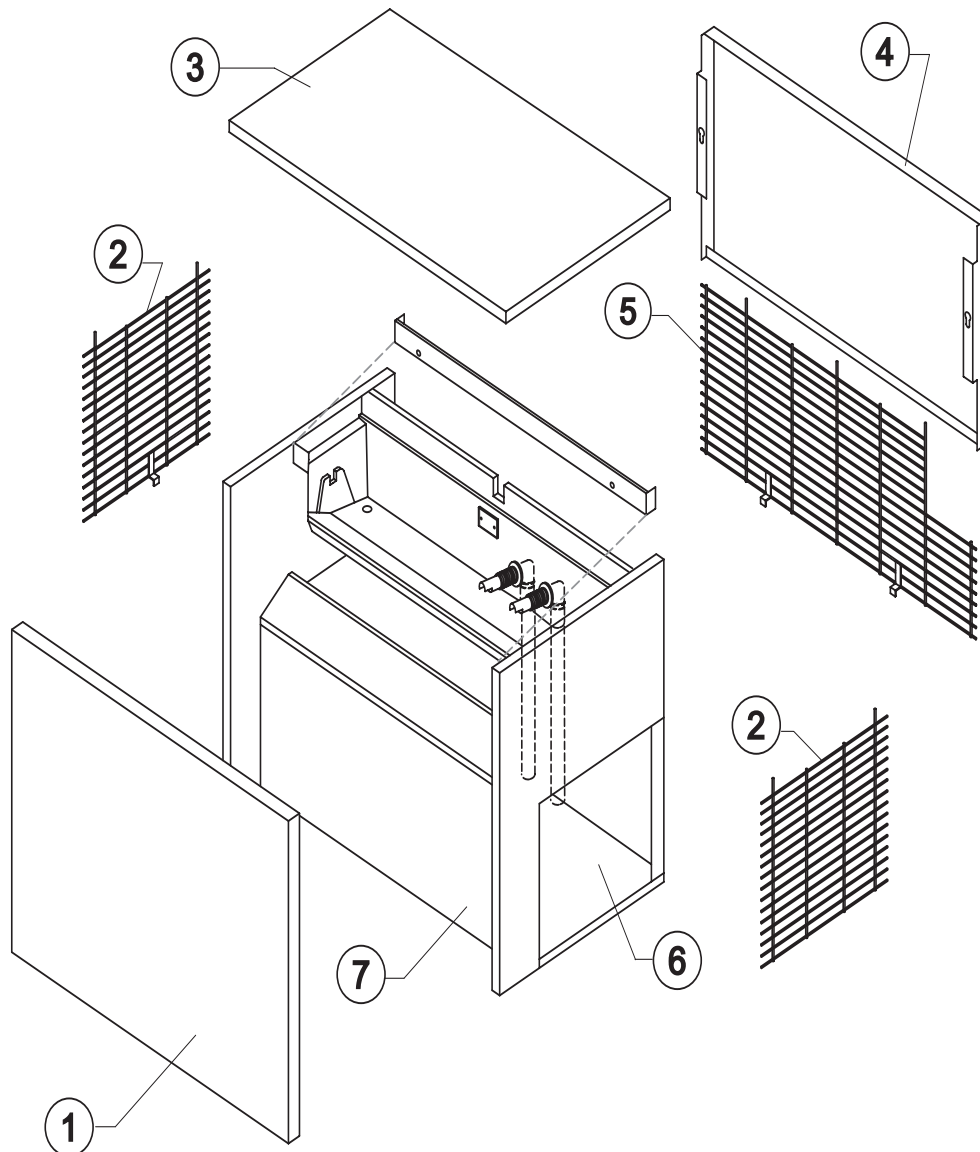

Ref.	Spare Description	Code
1	Front Panel Assembly	C22067
2	Side Grid	D12010
3	Top Assembly	C22066
4	Rear Panel	22027
5	Rear Grid	D12069
6	Base Plate	21022
7	Foamed Cabinet Assy	See Table

### Ref. 1 - Foamed Cabinet Assy

Condensation	Code
Air	C11005A
Water	C11005W

Rev. 10 - 21/06/2011



C 80

# COOLING SYSTEM

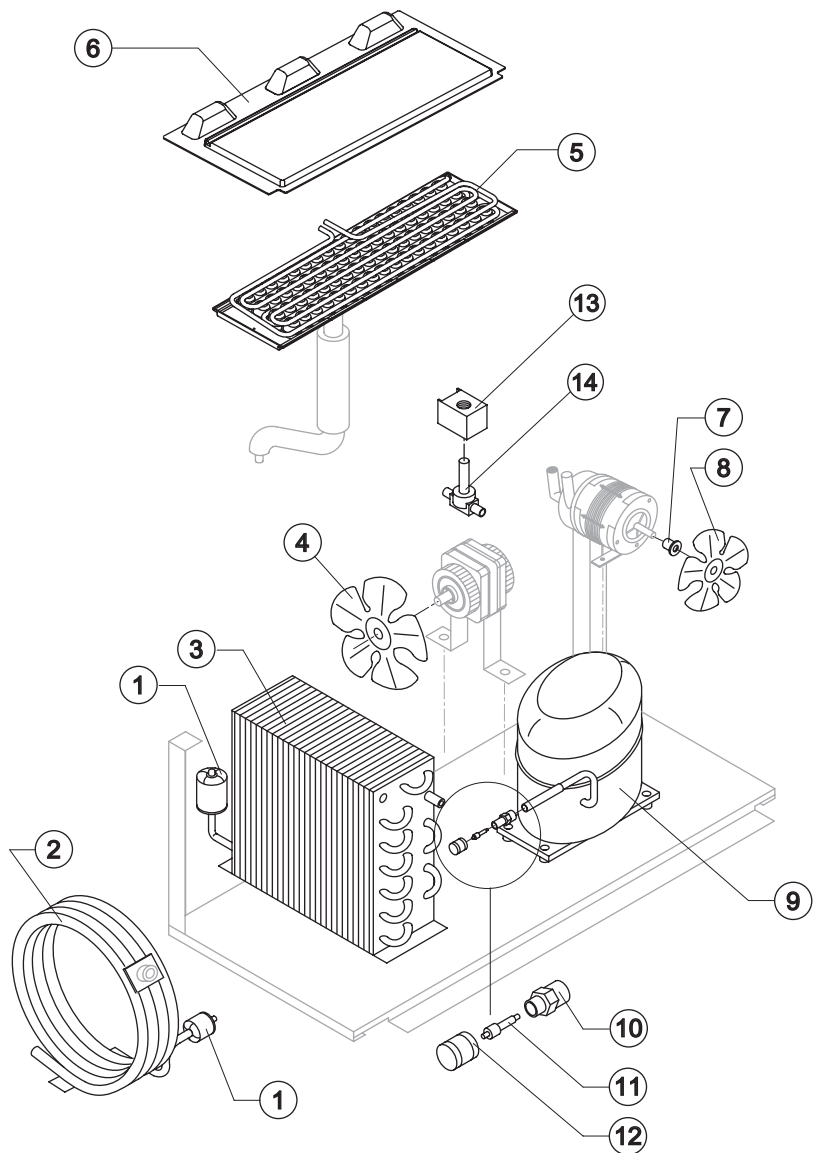

## Common Parts

Ref.	Spare Description	Code
1*	Solid Core Drier	14089
5	Evaporator	See Table
6	Evaporator Cover Panel	Current Version
6	Evaporator Cover Panel	Till s/n. 249637
7	Fan Fixing Hub	10014
8	Sucking Fan	10213
9	Compressor	See Table
10	Vacuum-Charge Valve Body	14007
11*	Vacuum-Charge Valve Device	14005
12*	Vacuum-Charge Valve Plug	14006
13*	Hot Gas Valve Coil	See Table
14*	Hot Gas Valve Body	20410

## Parts for Air-Cooled Version Only

Ref.	Spare Description	Code
3	Air Condenser	20030
4	Sucking Fan	20031

## Parts for Water-Cooled Version Only

Ref.	Spare Description	Code
2	Water Condenser	14034
4	Sucking Fan	Till s/n. 221219

## Rif. 5 - Evaporator

Kind of Cube	Code
18 g. (Standard)	D10048
33 g.	D10091
13 g.	D10419
42 g.	D10467

## Ref. 9 - Compressor

Voltage	Code
T11	23875
T12	23504A
T13	23553
T19	23553

## Ref. 13\* - Hot Gas Valve Coil

Voltage	Code
T11	23091
T12	23091
T13	23256
T19	23256

Rev. 10 - 21/06/2011



# C 80

# HYDRAULIC CIRCUIT

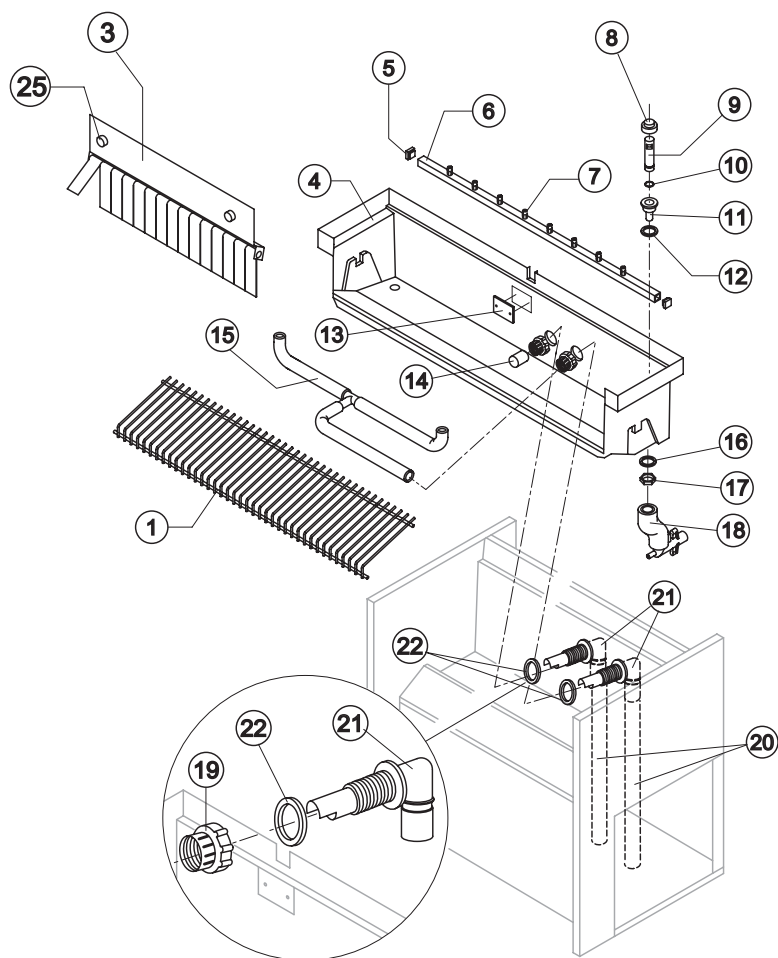

### Common Parts

Ref.	Spare Description	Code
1	Ices Cube Slide	See Table
3	Flags Support Assy	C22060
4	Inner Basin	10028
5	Sprayers Bag Plug	10012
6*	Sprayers Bar Assembly	See Table
7	Sprayer	D20002
8*	Overflow Cap	10305
9*	Overflow Pipe	10133
10*	OR Gasket for Overflow Pipe	20233
11	Water Outlet Nipple	10472
12	Silicone Gasket	13006
13	Slide Keep Plate	10009
14*	Pump Suction Filter	20005
15	Sprayers Feeding Pipe Assy	C13101
16	Semirigid Polyethylene Gasket	13007
17	Bin Discharge Nut	10096
19	Fittings Locking Ring	10405
20	Pump Suction/Delivery Pipe	13136
21	Fitting of the Pump Suction/Delivery Pipes	10404
22	Gasket for Pump Suction/Delivery Pipes	13143
25	Fixing Screw	20009

Rev. 10 - 21/06/2011

### R6f. 1 - Ice Cube Slide

Kind of Cube	Code
18 g. (Standard)	D12011
33 g.	D12032
13 g.	D12041
42 g.	D12032

### Ref. 6\* - Sprayers Bar Assy

Kind of Cube	Code
18 g. (Standard)	C20459
33 g.	C20460
13 g.	C20461
42 g.	C20460

### Parts for Air Cooled Version Only

Ref.	Spare Description	Code
18	Discharges Manifold	C10006

### Parts for Water Cooled Version Only

Ref.	Spare Description	Code
18	Discharges Manifold	C26452



# C 80

# ELECTRIC PARTS

### Common Parts

Ref.	Spare Description	Code
2*	Fan Motor	See Table
3*	1 Way- Water Inlet Valve	See Table
7*	Pump Assy	See Table
9	Contactors	Only T13 and T19
10*	Condenser Pressure Switch	See Table
11*	Bin Thermostat	R23421
12*	Evaporator Thermostat	R23591
13*	Timer	See Table
14*	On/Off Rocker Switch	23327

### Parts for Air-Cooled Version Only

Ref.	Spare Description	Code
8	Anti Radio Interference Filter	Only T11

### Parts for Water-Cooled Version Only

Ref.	Spare Description	Code
1*	Safety Thermostat	C23114
8	Anti Radio Interference Filter	Only T11

### Ref. 2\* - Fan Motor

Voltage	Air	Water
		Till s/n. 221219
T11	23067	23029
T12	23681	23029
T13	23621	23683
T19	23621	-

### Ref. 3\* - 1 Way- Water Inlet Valve

Voltage	18g/13g Cube	33g Cube	42g Cube
	T11	23001	23001
T12	23001	23220	23220
T13	23260	23631	23631
T19	23260	23631	23631

### Ref. 7\* - Pump Assy

Voltage	Code
T11	C23377
T12	C23377
T13	C23663
T19	C23663

### Ref. 10\* - Cond. Pressure Switch

Voltage	Code
T11	23175
T12	23175
T13	23175
T19	23680

### Ref. 13\* - Timer

Voltage	18g Cube	33g Cube	13g Cube	42g Cube
T11	23222	23248	23247	23780
T12	23248	23780	23247	23780
T13	23259	23786	23258	23786
T19	23259	23786	23258	23786

Rev. 10 - 21/06/2011

