

CUCINE A GAS Serie 900

TIPO: N9PC/G40..., N9PCV/G40..., N9PCVP/G40...,
N9PC/G80..., N9PCV/G80..., N9PCVP/G80...,
N9PC/G12..., N9PCV/G12..., N9PCVP/G12...,
N9PC/G16..., N9PCV/G16..., N9PCVP/G16...,
N9PCF/G80..., N9PCF/G12..., N9PCF/G16...,
N9PCF/GE80..., N9PCF/GE12..., N9PCF/GE16...

Ricambi



Egregio cliente,

Congratulazioni per aver scelto un'apparecchiatura BARON per le Sue attività gastronomiche. Si tratta, infatti, di un'ottima scelta e da parte nostra faremo del nostro meglio per assicurarci che anche Lei, come migliaia di altre persone in tutto il mondo, diventi un cliente BARON soddisfatto.

La invitiamo a leggere attentamente il manuale. Questo Le permetterà di apprendere numerose metodologie di lavoro corrette, sicure ed efficienti, in modo da trarre il maggior vantaggio dall'utilizzo della Sua nuova apparecchiatura. Grazie alle istruzioni ed ai suggerimenti riportati nel presente manuale, Lei potrà iniziare ad utilizzarla velocemente e senza alcuna difficoltà ed in breve tempo si accorgerà di quanto sia piacevole adoperare un prodotto BARON.

L'azienda si riserva il diritto di effettuare modifiche tecniche.

Tutti i principali dati tecnici vengono riportati nella targhetta di identificazione applicata sull'apparecchiatura. In caso di richiesta di assistenza o supporto tecnico, ci dovrà cortesemente comunicare la relativa matricola. Sarà così più facile per noi poterLe garantire un'assistenza tecnica adeguata. Le consigliamo inoltre di riportare nelle righe sottostanti i recapiti del centro assistenza BARON più vicino a Lei.

BARON TEAM

Numero BARON assistenza tecnica:.....

Persona da contattare:.....

9. Parti di ricambio

Parti esterne fuochi e armadio caldo..	76
Parti esterne forno gas ed elettrico.....	78
Bruciatori e condutture fuochi aperti.	80
Bruciatori e condutture fuochi aperti.	82
Rubinetto.....	84
Componenti forno a gas	86
Componenti forno elettrico e armadio caldo	88
Componenti accensione elettrica.....	90

9.1 Codici di voltaggio

Voltaggio	Codice di voltaggio
A	3/N/PE~400/230V 50Hz
B	~250V 16A 50Hz
C	3/N/PE~380/220V 50Hz
D	3/PE~200V 50-60Hz
F	2/PE 220-240V 50Hz
G	3/N/PE~415/240V 50Hz
H	3/PE~230V 50Hz
I	3/PE~220V 60Hz
J	3/PE~380 50Hz
K	3/PE~400V 50Hz
L	3/PE~415V 50Hz
M	3/PE~440V 60Hz
N	3/PE~460V 60Hz
O	3/PE~480V 60Hz
P	1/N/PE~220-240V 50Hz
R	2/PE~220-230V 60Hz
S	3/N/PE~400/230V 50Hz
T	3/PE~230V 60Hz
U	1/N/PE~100V 50-60Hz

9.2 Codici dei prodotti

Codici del prodotto	Nome completo
Codici dei modelli	
Codici dei tipi	
400G	N9PC/G400
800G	N9PC/G800
120G	N9PC/G120
160G	N9PC/G160
400VG	N9PCV/G400
800VG	N9PCV/G800
120VG	N9PCV/G120
160VG	N9PCV/G160
800FG	N9PCF/G800
120FG	N9PCF/G120
160FG	N9PCF/G160
800FGE	N9PCF/GE800
120FGE	N9PCF/GE120
160FGE	N9PCF/GE160
411G	N9PC/G411
811G	N9PC/G811
121G	N9PC/G121
161G	N9PC/G161

Parti di ricambio

Codici del prodotto	Nome completo
411VG	N9PCV/G411
811VG	N9PCV/G811
121VG	N9PCV/G121
161VG	N9PCV/G161
811FG	N9PCF/G811
121FG	N9PCF/G121
161FG	N9PCF/G161
811FGE	N9PCF/GE811
121FGE	N9PCF/GE121
161FGE	N9PCF/GE161
Codici degli accessori	

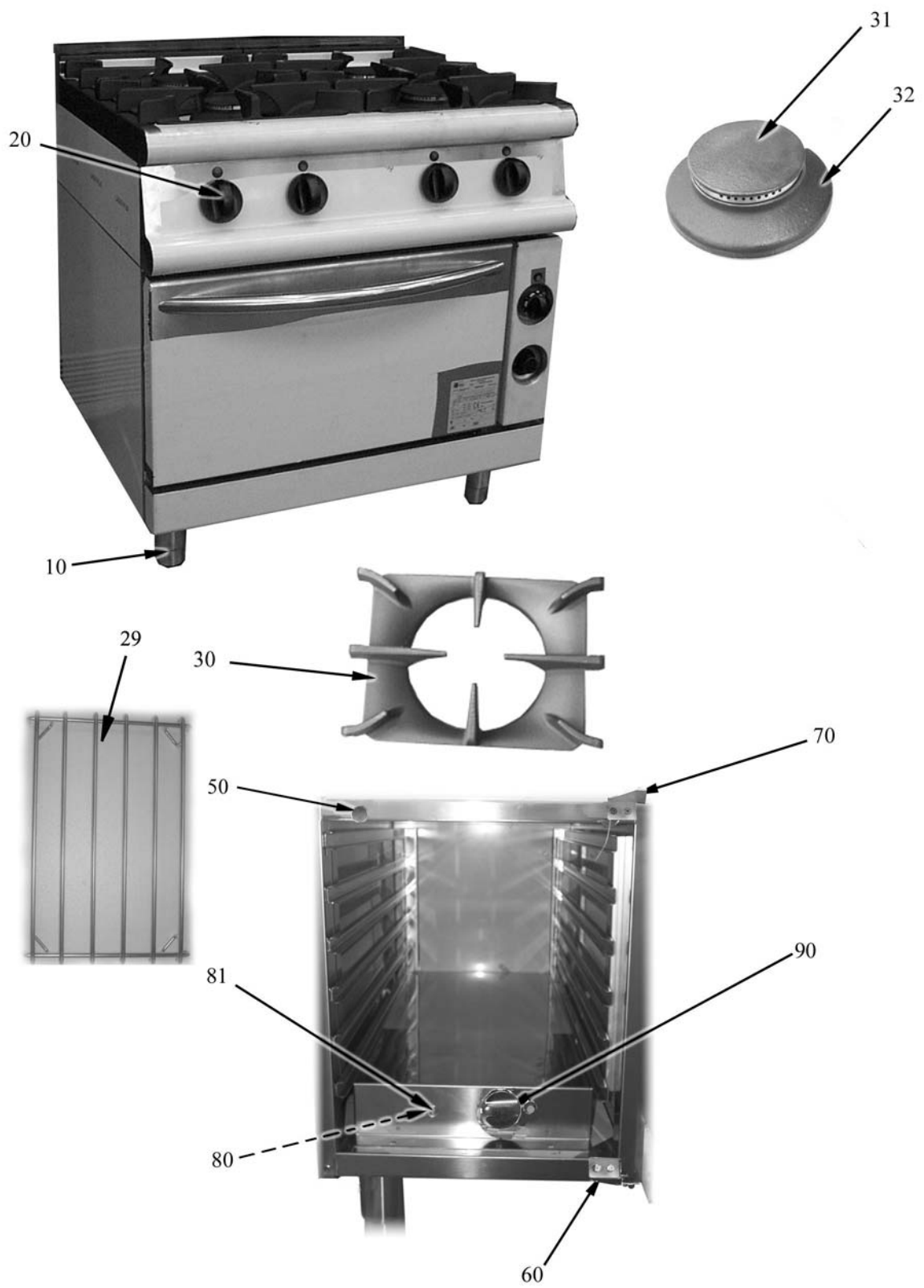

Parti di ricambio

ID	Modello	Tipo	Voltaggio	Descrizione	Codici del produttore
Module: Parti esterne fuochi e armadio caldo					
10				Piedino	826490142
20				Manopola cucina gas nera	824710100
29				Griglia bifuoco inox	8266330180
30				Griglia smaltata	BN822410690
31				Bruciatore (spartifiamma piccolo)	822410071
31				Bruciatore (spartifiamma medio)	822410081
31		800G,800VG,800FG,800FGE,120G,120VG,120FG,120FGE,160G,160VG,160FG,160FGE,811G,811VG,811FG,811FGE,121G,121VG,121FG,121FGE,161G,161VG,161FG,161FGE		Bruciatore (spartifiamma "E") 7kW	822410091
31				Bruciatore spartifiamma 10 kW	BN822410640
32				Corpo Bruciatore piccolo	BN822410650
32				Corpo Bruciatore medio	BN822410660
32		800G,800VG,800FG,800FGE,120G,120VG,120FG,120FGE,160G,160VG,160FG,160FGE,811G,811VG,811FG,811FGE,121G,121VG,121FG,121FGE,161G,161VG,161FG,161FGE		Bruciatore (bicchiere "E")	BN822410670
50		120FG,120FGE,121FG,121FGE		Magnete	826900011
60		120FG,120FGE,121FG,121FGE		Cerniera inferiore dx/superiore sx porta	418S2547870
70		120FG,120FGE,121FG,121FGE		Cerniera inferiore sx/superiore dx porta	418S2547860
80		800FGE,120FGE,160FGE,811FGE,121FGE		Segnalatore luminoso verde	826650050
81		800FGE,120FGE,160FGE,811FGE,121FGE		Gemma bianca	6A039207

400G=N9PC/G400, 800G=N9PC/G800, 120G=N9PC/G120, 160G=N9PC/G160, 400VG=N9PCV/G400, 800VG=N9PCV/G800, 120VG=N9PCV/G120, 160VG=N9PCV/G160, 800FG=N9PCF/G800,120FG=N9PCF/G120,160FG=N9PCF/G160, 800FGE=N9PCF/GE800, 120FGE=N9PCF/GE120, 160FGE=N9PCF/GE160, 411G=N9PC/G411, 811G=N9PC/G811, 121G=N9PC/G121, 161G=N9PC/G161, 411VG=N9PCV/G411, 811VG=N9PCV/G811, 121VG=N9PCV/G121, 161VG=N9PCV/G161, 811FG=N9PCF/G811, 121FG=N9PCF/G121, 161FG=N9PCF/G161, 811FGE=N9PCF/GE811, 121FGE=N9PCF/GE121, 161FGE=N9PCF/GE161

A=3/N/PE~400/230V 50Hz, H=3/PE~230V 50Hz, P=1/N/PE~220-240V 50Hz

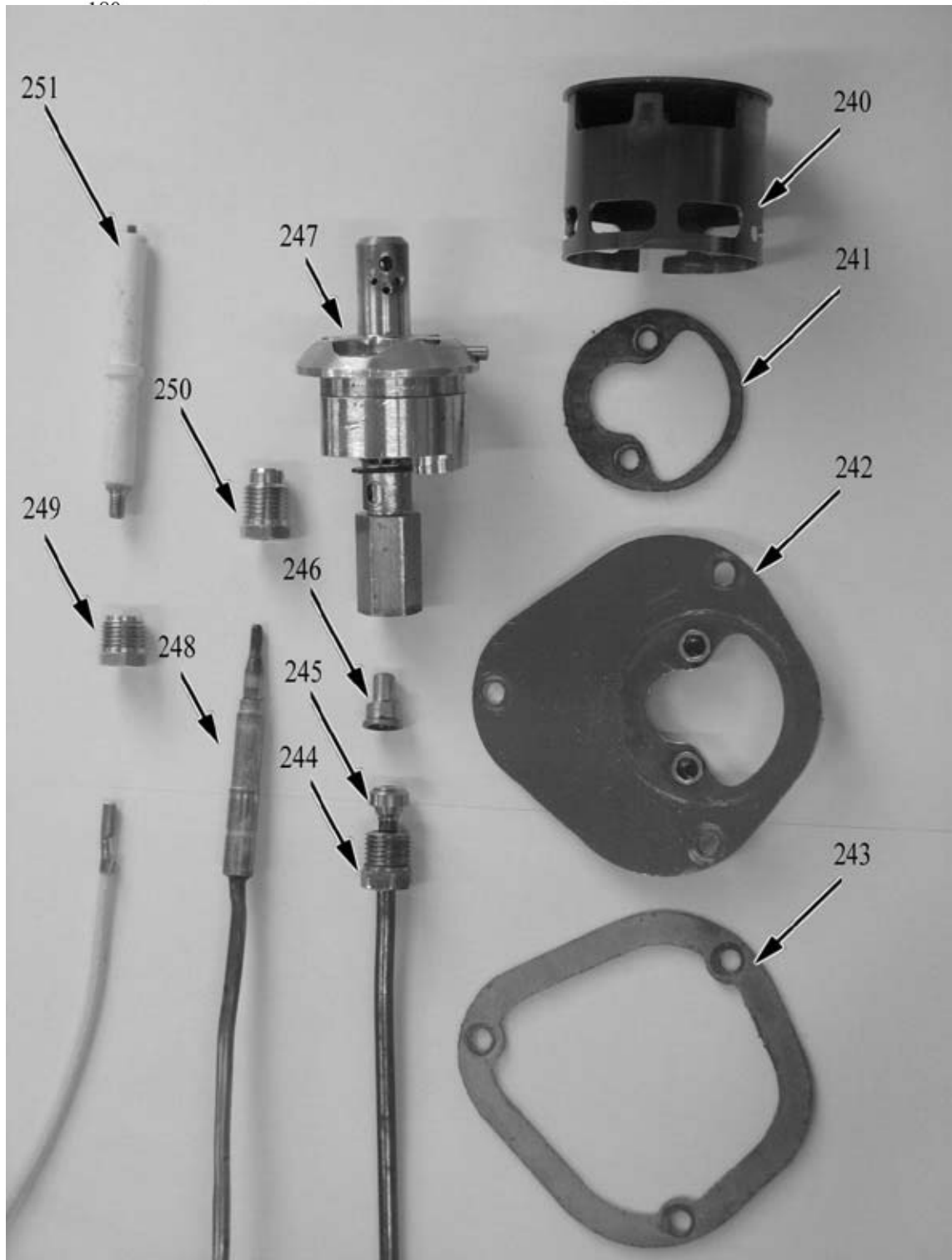

Parti di ricambio

ID	Modello	Tipo	Voltaggio	Descrizione	Codici del produttore
Module: Parti esterne forno gas ed elettrico					
80		800FGE,120FGE,160FGE,811FGE,121FGE		Segnalatore luminoso verde	826650050
81		800FGE,120FGE,160FGE,811FGE,121FGE		Gemma bianca	6A039207
100		800FG,120FG,160FG,811FG,121FG,161FG		Manopola nera per forno	824710110
110		800FG,120FG,160FG,811FG,121FG,161FG		Accensione piezoelettrica	41826630020
120		800FG,120FG,160FG,811FG,121FG,161FG		Rondella	822160540
130		800FG,120FG,160FG,811FG,121FG,161FG		Cappuccio	826630420
140		800FG,120FG,160FG,800FGE,120FGE,160FGE,811FG,121FG,161FG,811FGE,121FGE,161FGE		Portarullini per cerniera	6A035930
150		800FG,120FG,160FG,800FGE,120FGE,160FGE,811FG,121FG,161FG,811FGE,121FGE,161FGE		Cerniera dx	6A035910
160		800FG,120FG,160FG,800FGE,120FGE,160FGE,811FG,121FG,161FG,811FGE,121FGE,161FGE		Cerniera sx	6A035920
170		800FG,120FG,160FG,800FGE,120FGE,160FGE,811FG,121FG,161FG,811FGE,121FGE,161FGE		Suola forno	822420010
180		800FG,120FG,160FG,800FGE,120FGE,160FGE,811FG,121FG,161FG,811FGE,121FGE,161FGE		Griglia	826330020
190		800FGE,120FGE,160FGE,811FGE,121FGE,161FGE		Segnalatore luminoso arancio	6A038506
200		800FGE,120FGE,160FGE,811FGE,121FGE,161FGE		Manopola commutatore forno elettrico	824710710
210		800FGE,120FGE,160FGE,811FGE,121FGE,161FGE		Manopola forno elettrico nera	824710270
220		800FGE,120FGE,160FGE,811FGE,121FGE,161FGE		Resistenza 1500 W	826620041

400G=N9PC/G400, 800G=N9PC/G800, 120G=N9PC/G120, 160G=N9PC/G160, 400VG=N9PCV/G400, 800VG=N9PCV/G800, 120VG=N9PCV/G120, 160VG=N9PCV/G160, 800FG=N9PCF/G800,120FG=N9PCF/G120,160FG=N9PCF/G160, 800FGE=N9PCF/GE800, 120FGE=N9PCF/GE120, 160FGE=N9PCF/GE160, 411G=N9PC/G411, 811G=N9PC/G811, 121G=N9PC/G121, 161G=N9PC/G161, 411VG=N9PCV/G411, 811VG=N9PCV/G811, 121VG=N9PCV/G121, 161VG=N9PCV/G161, 811FG=N9PCF/G811, 121FG=N9PCF/G121, 161FG=N9PCF/G161, 811FGE=N9PCF/GE811, 121FGE=N9PCF/GE121, 161FGE=N9PCF/GE161

A=3/N/PE~400/230V 50Hz, H=3/PE~230V 50Hz, P=1/N/PE~220-240V 50Hz

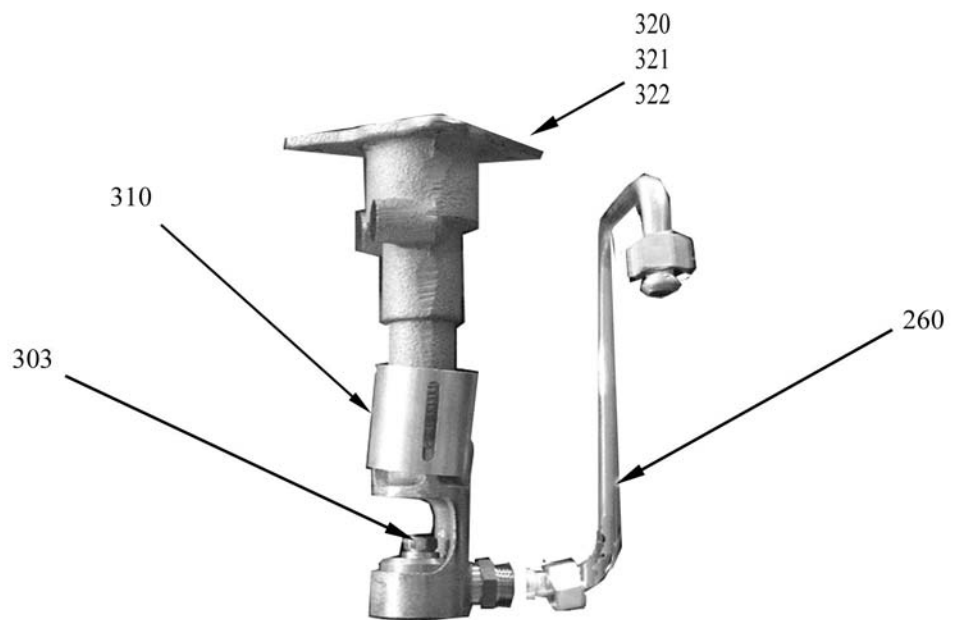
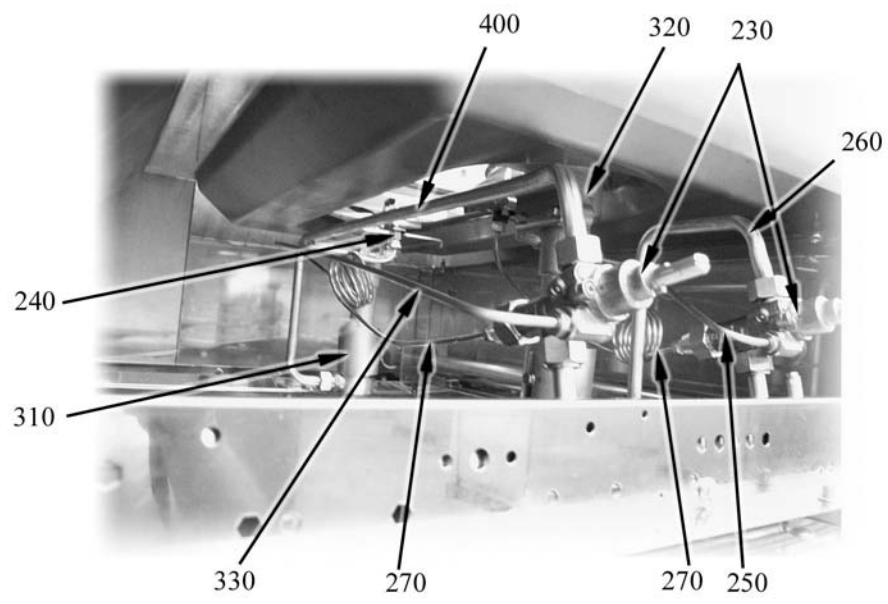

Parti di ricambio

ID	Tipo	Descrizione	Codici del produttore
Module: Bruciatori e condutture fuochi aperti			
230		Rubinetto	6A011490
240		Pilota	BN822160580
250		Conduttura Rub./Pil. ant.	BN823561730
260		Conduttura Rub./Bruc. ant	823561300
270		Termocoppia	826920080
303		Ugello 80	BN822140270
303		Ugello 85	BN822140130
303		Ugello 90	BN41822140620
303		Ugello 100	BN822140630
303		Ugello 110	BN41822140010
303		Ugello 115	BN822140280
303		Ugello 120	BN822140160
303		Ugello 125	BN41822140020
303		Ugello 130	BN822140030
303		Ugello 135	BN822140170
303		Ugello 140	BN41822140180
303		Ugello 150	BN41822140420
303		Ugello 165	BN822140200
303		Ugello 175	BN41822140640
303		Ugello 180	BN822140210
303		Ugello 185	BN822140650
303		Ugello 195	BN822140580
303		Ugello 205	BN822140290
303		Ugello 215	BN822140600
303		Ugello 220	BN822140070
303		Ugello 235	BN822140230
303		Ugello 245	BN822140100
303		Ugello 260	BN822140660
310		Regolatore d'aria	822120020
320		Venturi medio	822410022
321		Venturi piccolo	822410012
322	800G,800VG,800FG,800FGE,120G,120VG,120FG,120FGE,160G,160VG,160FG,160FGE,811G,811VG,811FG,811FGE,121G,121VG,121FG,121FGE,161G,161VG,161FG,161FGE	Venturi grande	822410032
330		Conduttura Rub./Pil. post.	BN823561720
400		Conduttura Rub./Bruc. Post.	823561310

400G=N9PC/G400, 800G=N9PC/G800, 120G=N9PC/G120, 160G=N9PC/G160, 400VG=N9PCV/G400, 800VG=N9PCV/G800, 120VG=N9PCV/G120, 160VG=N9PCV/G160, 800FG=N9PCF/G800,120FG=N9PCF/G120,160FG=N9PCF/G160, 800FGE=N9PCF/GE800, 120FGE=N9PCF/GE120, 160FGE=N9PCF/GE160, 411G=N9PC/G411, 811G=N9PC/G811, 121G=N9PC/G121, 161G=N9PC/G161, 411VG=N9PCV/G411, 811VG=N9PCV/G811, 121VG=N9PCV/G121, 161VG=N9PCV/G161, 811FG=N9PCF/G811, 121FG=N9PCF/G121, 161FG=N9PCF/G161, 811FGE=N9PCF/GE811, 121FGE=N9PCF/GE121, 161FGE=N9PCF/GE161

A=3/N/PE~400/230V 50Hz, H=3/PE~230V 50Hz, P=1/N/PE~220-240V 50Hz

Parti di ricambio

ID	Modello	Tipo	Voltaggio	Descrizione	Codici del produttore
Module: Bruciatori e condutture fuochi aperti					
240				Copertura pilota	BN826350260
241				Guarnizione pilota	BN825110520
242				Squadretta pilota bruc. piccolo	BN821122510
242				Squadretta pilota bruc. medio	BN821122520
242				Squadretta pilota bruc. grande	BN821122530
243				Guarnizione finestra pilota	BN825110530
244				Raccordo	BN6A01700
245				Conduttura pilota	BN6A016900
246				Ugello pilota	BN6A013240
246				Ugello pilota	BN6A013230
246				Ugello pilota	BN2510334
247				Corpo pilota	BN822160580
248				Termocoppia	BN826920080
249				Raccordo	BN6A011707
250				Raccordo termocoppia	BN6A011708
251				Candela accensione	CR0687080

400G=N9PC/G400, 800G=N9PC/G800, 120G=N9PC/G120, 160G=N9PC/G160, 400VG=N9PCV/G400, 800VG=N9PCV/G800, 120VG=N9PCV/G120, 160VG=N9PCV/G160, 800FG=N9PCF/G800, 120FG=N9PCF/G120, 160FG=N9PCF/G160, 800FGE=N9PCF/GE800, 120FGE=N9PCF/GE120, 160FGE=N9PCF/GE160, 411G=N9PC/G411, 811G=N9PC/G811, 121G=N9PC/G121, 161G=N9PC/G161, 411VG=N9PCV/G411, 811VG=N9PCV/G811, 121VG=N9PCV/G121, 161VG=N9PCV/G161, 811FG=N9PCF/G811, 121FG=N9PCF/G121, 161FG=N9PCF/G161, 811FGE=N9PCF/GE811, 121FGE=N9PCF/GE121, 161FGE=N9PCF/GE161

A=3/N/PE~400/230V 50Hz, H=3/PE~230V 50Hz, P=1/N/PE~220-240V 50Hz

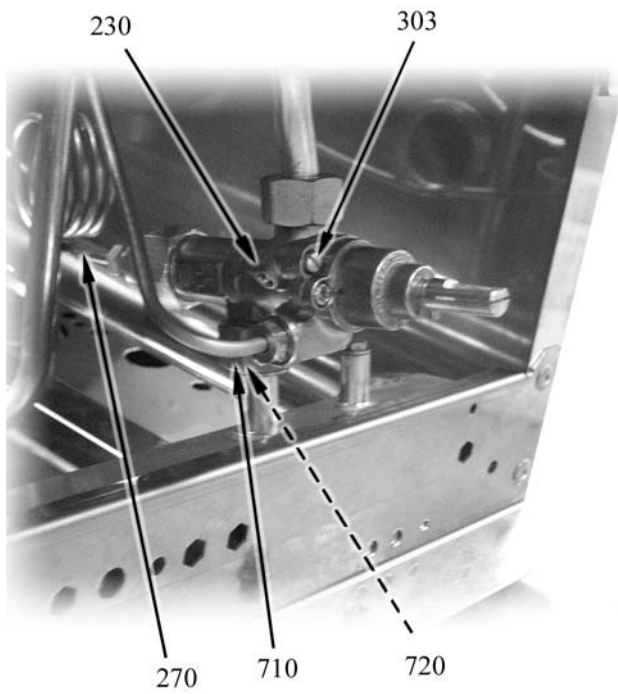

Parti di ricambio

ID	Modello	Tipo	Voltaggio	Descrizione	Codici del produttore
Module:Rubinetto					
230				Rubinetto	6A011490
270				Termocoppia	826920080
303				Vite di minimo 45	BN6A023722
303				Vite di minimo 50	BN822450210
303				Vite di minimo 55	BN822450720
303				Vite di minimo 65	BN6A023723
303				Vite di minimo 70	BN6A023721
303				Vite di minimo 75	BN822450230
303				Vite di minimo 80	BN822450240
303				Vite di minimo 85	BN6A023726
303				Vite di minimo 90	BN822450260
303				Vite di minimo 115	BN6A023724
303				Vite di minimo 120	BN822450280
303				Vite di minimo 145	BN41822450360
710				Dado	6A011485
720				Bicono	6A011480

400G=N9PC/G400, 800G=N9PC/G800, 120G=N9PC/G120, 160G=N9PC/G160, 400VG=N9PCV/G400, 800VG=N9PCV/G800, 120VG=N9PCV/G120, 160VG=N9PCV/G160, 800FG=N9PCF/G800, 120FG=N9PCF/G120, 160FG=N9PCF/G160, 800FGE=N9PCF/GE800, 120FGE=N9PCF/GE120, 160FGE=N9PCF/GE160, 411G=N9PC/G411, 811G=N9PC/G811, 121G=N9PC/G121, 161G=N9PC/G161, 411VG=N9PCV/G411, 811VG=N9PCV/G811, 121VG=N9PCV/G121, 161VG=N9PCV/G161, 811FG=N9PCF/G811, 121FG=N9PCF/G121, 161FG=N9PCF/G161, 811FGE=N9PCF/GE811, 121FGE=N9PCF/GE121, 161FGE=N9PCF/GE161

A=3/N/PE~400/230V 50Hz, H=3/PE~230V 50Hz, P=1/N/PE~220-240V 50Hz

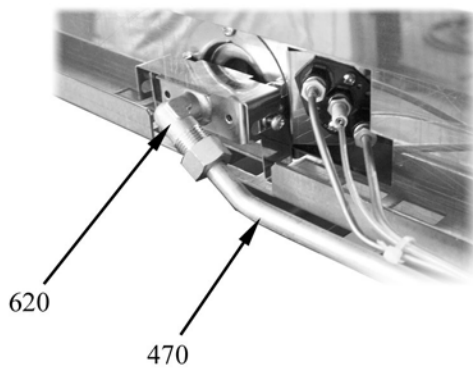
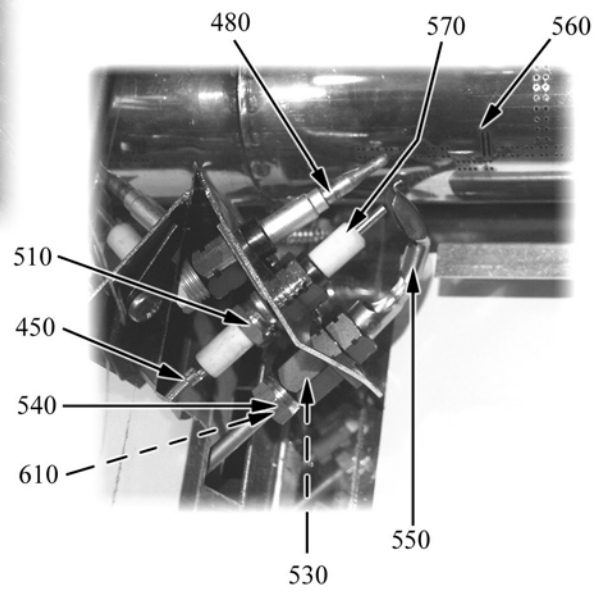
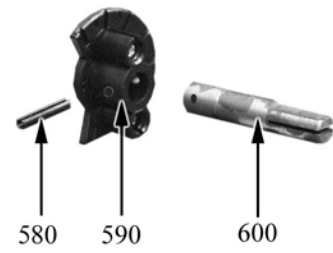
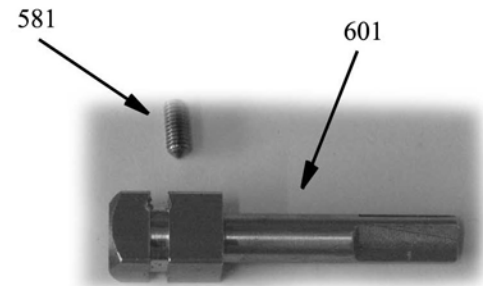
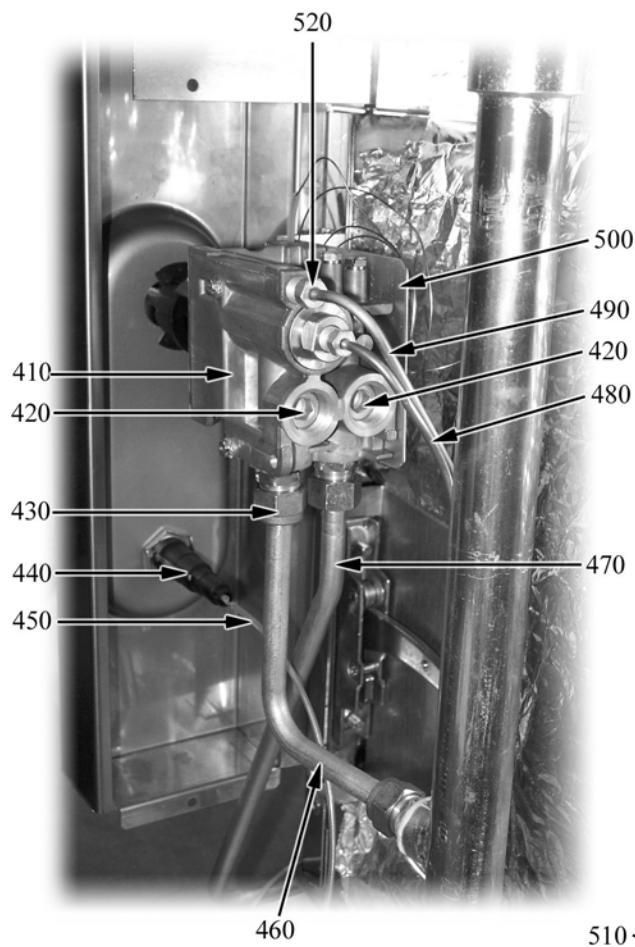

Parti di ricambio

ID	Modello	Tipo	Voltaggio	Descrizione	Codici del produttore
Module: Componenti forno a gas (valvola, regolazione aria, bruciatore)					
410		800FG,120FG,160FG,811FG,121FG,161FG		Valvola	826920012
420		800FG,120FG,160FG,811FG,121FG,161FG		Tappo	8219951
430		800FG,120FG,160FG,811FG,121FG,161FG		Raccordo	822450170
440		800FG,120FG,160FG,811FG,121FG,161FG		Accensione piezoelettrica	41826630020
450		800FG,120FG,160FG,811FG,121FG,161FG		Cavo d'accensione	2510698
460		800FG,120FG,160FG,811FG,121FG,161FG		Conduttura Valvola/Rampa	2514615
470		800FG,120FG,160FG,811FG,121FG,161FG		Conduttura Valvola/Bruciatore forno	823560060
480		800FG,120FG,160FG,811FG,121FG,161FG		Termocoppia	826920080
490		800FG,120FG,160FG,811FG,121FG,161FG		Conduttura Valvola/Pilota forno	823560070
500		800FG,120FG,160FG,811FG,121FG,161FG		Squadretta	41821120040
510		800FG,120FG,160FG,811FG,121FG,161FG		Raccordo	6A011707
520		800FG,120FG,160FG,811FG,121FG,161FG		Raccordo bicono	6A011608
530		800FG,120FG,160FG,811FG,121FG,161FG		Ugello 19	822140380
530		800FG,120FG,160FG,811FG,121FG,161FG		Ugello 27	6A013107
540		800FG,120FG,160FG,811FG,121FG,161FG		Raccordo	822450040
550		800FG,120FG,160FG,811FG,121FG,161FG		Pilota	826920070
560		800FG,120FG,160FG,811FG,121FG,161FG		Bruciatore	2510697
570		800FG,120FG,160FG,811FG,121FG,161FG		Candela	6A013301
580		800FG,120FG,160FG,811FG,121FG,161FG		Spina elastica	418227993140
581		800FG,120FG,160FG,811FG,121FG,161FG		Grano di fissaggio	6A009190
590		800FG,120FG,160FG,811FG,121FG,161FG		Flangia	41822160011
600		800FG,120FG,160FG,811FG,121FG,161FG		Attacco manopola	2518650
601		800FG,120FG,160FG,811FG,121FG,161FG		Attacco manopola	2518660
610		800FG,120FG,160FG,811FG,121FG,161FG		Bicono	822450050
620		800FG,120FG,160FG,811FG,121FG,161FG		Raccordo	822450010

400G=N9PC/G400, 800G=N9PC/G800, 120G=N9PC/G120, 160G=N9PC/G160, 400VG=N9PCV/G400, 800VG=N9PCV/G800, 120VG=N9PCV/G120, 160VG=N9PCV/G160, 800FG=N9PCF/G800, 120FG=N9PCF/G120, 160FG=N9PCF/G160, 800FGE=N9PCF/GE800, 120FGE=N9PCF/GE120, 160FGE=N9PCF/GE160, 411G=N9PC/G411, 811G=N9PC/G811, 121G=N9PC/G121, 161G=N9PC/G161, 411VG=N9PCV/G411, 811VG=N9PCV/G811, 121VG=N9PCV/G121, 161VG=N9PCV/G161, 811FG=N9PCF/G811, 121FG=N9PCF/G121, 161FG=N9PCF/G161, 811FGE=N9PCF/GE811, 121FGE=N9PCF/GE121, 161FGE=N9PCF/GE161

A=3/N/PE~400/230V 50Hz, H=3/PE~230V 50Hz, P=1/N/PE~220-240V 50Hz

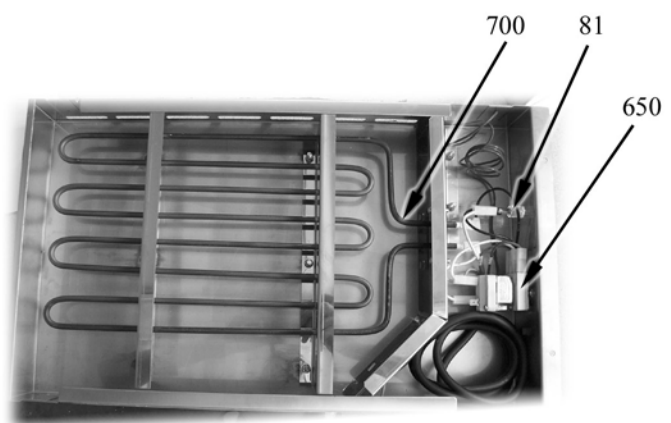
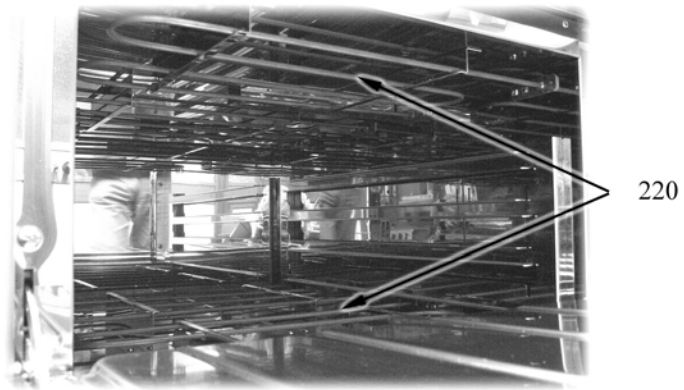
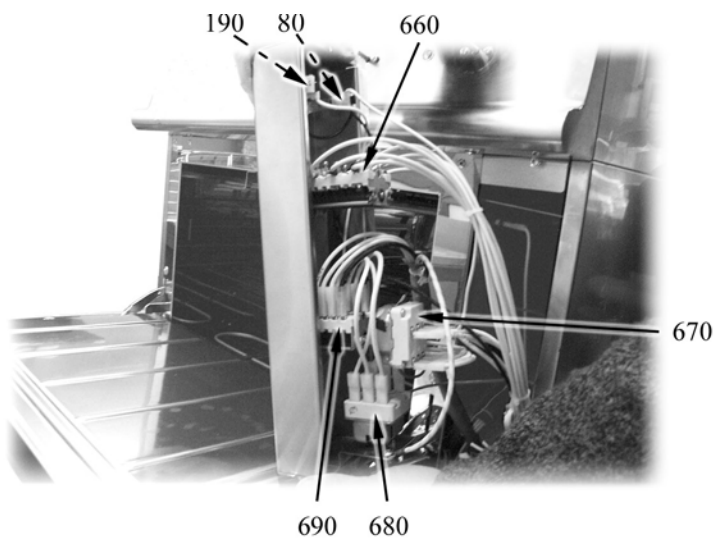

Parti di ricambio

ID	Modello	Tipo	Voltaggio	Descrizione	Codici del produttore
Module: Componenti forno elettrico e armadio caldo					
80		800FGE,120FGE,160FGE,811FGE,121FGE,161FGE		Segnalatore luminoso verde	826650050
81		800FGE,120FGE,160FGE,811FGE,121FGE,161FGE		Gemma bianca	6A039207
190		800FGE,120FGE,160FGE,811FGE,121FGE,161FGE		Segnalatore luminoso arancio	6A038506
220		800FGE,120FGE,160FGE,811FGE,121FGE,161FGE		Resistenza 1500 W	826620041
660		800FGE,120FGE,160FGE,811FGE,121FGE,161FGE		Commutatore	6A046750
670		800FGE,120FGE,160FGE,811FGE,121FGE,161FGE		Termostato	826630123
680		800FGE,120FGE,160FGE,811FGE,121FGE,161FGE		Termostato sicurezza	826630130
690		800FGE,120FGE,160FGE,811FGE,121FGE,161FGE		Commutatore	6A046001

400G=N9PC/G400, 800G=N9PC/G800, 120G=N9PC/G120, 160G=N9PC/G160, 400VG=N9PCV/G400, 800VG=N9PCV/G800, 120VG=N9PCV/G120, 160VG=N9PCV/G160, 800FG=N9PCF/G800,120FG=N9PCF/G120,160FG=N9PCF/G160, 800FGE=N9PCF/GE800, 120FGE=N9PCF/GE120, 160FGE=N9PCF/GE160, 411G=N9PC/G411, 811G=N9PC/G811, 121G=N9PC/G121, 161G=N9PC/G161, 411VG=N9PCV/G411, 811VG=N9PCV/G811, 121VG=N9PCV/G121, 161VG=N9PCV/G161, 811FG=N9PCF/G811, 121FG=N9PCF/G121, 161FG=N9PCF/G161, 811FGE=N9PCF/GE811, 121FGE=N9PCF/GE121, 161FGE=N9PCF/GE161

A=3/N/PE~400/230V 50Hz, H=3/PE~230V 50Hz, P=1/N/PE~220-240V 50Hz

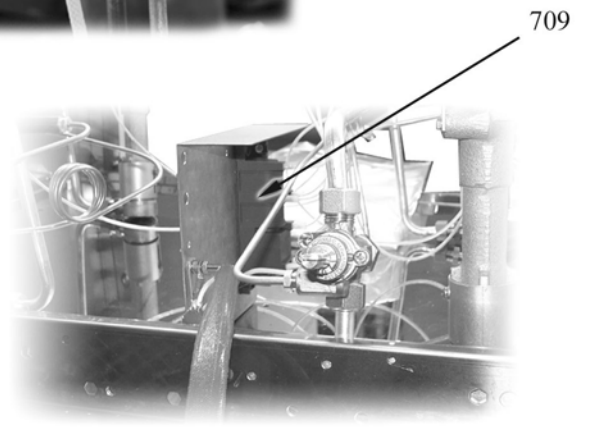
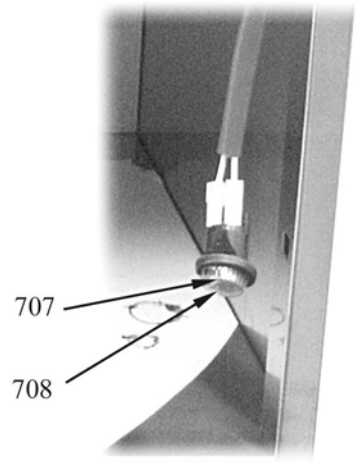
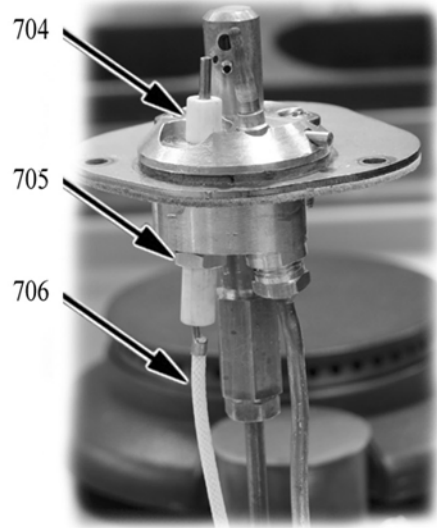

Parti di ricambio

ID	Modello	Tipo	Voltaggio	Descrizione	Codici del produttore
Module:Componenti accensione elettrica					
702		411G,411VG,811G,811VG,811FG,811FGE,121G,121VG,121FG,121FGE,161G,161VG,161FG,161FGE		Piletta di scarico	822160101
703		411G,411VG,811G,811VG,811FG,811FGE,121G,121VG,121FG,121FGE,161G,161VG,161FG,161FGE		Guarnizione	824710280
704		411G,411VG,811G,811VG,811FG,811FGE,121G,121VG,121FG,121FGE,161G,161VG,161FG,161FGE		Candela	CR0687080
705		411G,411VG,811G,811VG,811FG,811FGE,121G,121VG,121FG,121FGE,161G,161VG,161FG,161FGE		Dado candela	BN6A011707
706		411G,411VG,811G,811VG,811FG,811FGE,121G,121VG,121FG,121FGE,161G,161VG,161FG,161FGE		Cavo d'accensione L=600	826690820
706		411G,411VG,811G,811VG,811FG,811FGE,121G,121VG,121FG,121FGE,161G,161VG,161FG,161FGE		Cavo d'accensione L=1100	826690810
706		411G,411VG,811G,811VG,811FG,811FGE,121G,121VG,121FG,121FGE,161G,161VG,161FG,161FGE		Cavo d'accensione L=1900	826690830
707		411G,411VG,811G,811VG,811FG,811FGE,121G,121VG,121FG,121FGE,161G,161VG,161FG,161FGE		Tasto rosso	826630050
708		411G,411VG,811G,811VG,811FG,811FGE,121G,121VG,121FG,121FGE,161G,161VG,161FG,161FGE		Cappuccio	826630060
709		411G,411VG,811G,811VG,811FG,811FGE,121G,121VG,121FG,121FGE,161G,161VG,161FG,161FGE		Trasformatore	826630400

400G=N9PC/G400, 800G=N9PC/G800, 120G=N9PC/G120, 160G=N9PC/G160, 400VG=N9PCV/G400, 800VG=N9PCV/G800, 120VG=N9PCV/G120, 160VG=N9PCV/G160, 800FG=N9PCF/G800,120FG=N9PCF/G120,160FG=N9PCF/G160, 800FGE=N9PCF/GE800, 120FGE=N9PCF/GE120, 160FGE= N9PCF/GE160, 411G=N9PC/G411, 811G=N9PC/G811, 121G=N9PC/G121, 161G=N9PC/G161, 411VG=N9PCV/G411, 811VG=N9PCV/G811, 121VG= N9PCV/G121, 161VG=N9PCV/G161, 811FG=N9PCF/G811, 121FG=N9PCF/G121, 161FG=N9PCF/G161, 811FGE=N9PCF/GE811, 121FGE=N9PCF/GE121, 161FGE=N9PCF/GE161

A=3/N/PE~400/230V 50Hz, H=3/PE~230V 50Hz, P=1/N/PE~220-240V 50Hz

