

# CUCINE TUTTAPIASTRA A GAS Serie 700

TIPO: 7TP/G800, 7TP/G120 DX, 7TP/G120 SX, 7TPM/G800 SX, 7TPM/G120, 7TP/G160,  
7TPV/G800, 7TPV/G120 SX, 7TPV/G120 DX, 7TPMV/G800 SX, 7TPMV/G120, 7TPV/  
G160, 7TPF/G800, 7TPF/GE800, 7TPF/G120, 7TPF/GE120, 7TPMF/G120, 7TPMF/GE120,  
7TPMF/G800 SX, 7TPMF/GE800 SX, 7TP2F/G160, 7TP2F/GE160

---

## Ricambi

---





## **9. Parti di ricambio**

<b>Parti esterne fuochi .....</b>	<b>73</b>
<b>Parti esterne forno gas ed elettrico .....</b>	<b>75</b>
<b>Bruciatori e condutture fuochi aperti.</b>	<b>77</b>
<b>Bruciatori e condutture fuochi aperti.</b>	<b>81</b>
<b>Rubinetto.....</b>	<b>83</b>
<b>Componenti forno a gas .....</b>	<b>85</b>
<b>Componenti forno elettrico .....</b>	<b>87</b>
<b>Bruciatore tuttapiastra 1 modulo .....</b>	<b>89</b>
<b>Bruciatore tuttapiastra 1/2 modulo..</b>	<b>91</b>



## 9.1 Codici di voltaggio

Voltaggio	Codice di voltaggio
A	3/N/PE~400/230V 50Hz
B	~250V 16A 50Hz
C	3/N/PE~380/220V 50Hz
D	3/PE~200V 50-60Hz
F	2/PE 220-240V 50Hz
G	3/N/PE~415/240V 50Hz
H	3/PE~230V 50Hz
I	3/PE~220V 60Hz
J	3/PE~380 50Hz
K	3/PE~400V 50Hz
L	3/PE~415V 50Hz
M	3/PE~440V 60Hz
N	3/PE~460V 60Hz
O	3/PE~480V 60Hz
P	1/N/PE~220-240V 50Hz
R	2/PE~220-230V 60Hz
S	3/N/PE~400/230V 50Hz
T	3/PE~230V 60Hz
U	1/N/PE~100V 50-60Hz

## 9.2 Codici dei prodotti

Codici del prodotto	Nome completo
Codici dei modelli	
Codici dei tipi	
800	7TP/G800
120D	7TP/G120 DX
120S	7TP/G120 SX
800M	7TPM/G800 SX
120M	7TPM/G120
160	7TP/G160
800V	7TPV/G800
120S	7TPV/G120 SX
120D	7TPV/G120 DX
800MV	7TPMV/G800
120MV	7TPMV/G120
160V	7TPV/G160
800F	7TPF/G800
800FE	7TPF/GE800
120F	7TPF/G120
120FE	7TPF/GE120
120MF	7TPMF/G120

**Parti di ricambio**

---

Codici del prodotto	Nome completo
120MFE	7TPMF/GE120
800MF	7TPMF/G800 SX
800MFE	7TPMF/GE800
160F	7TP2F/G160
160FE	7TP2F/GE160
Codici degli accessori	



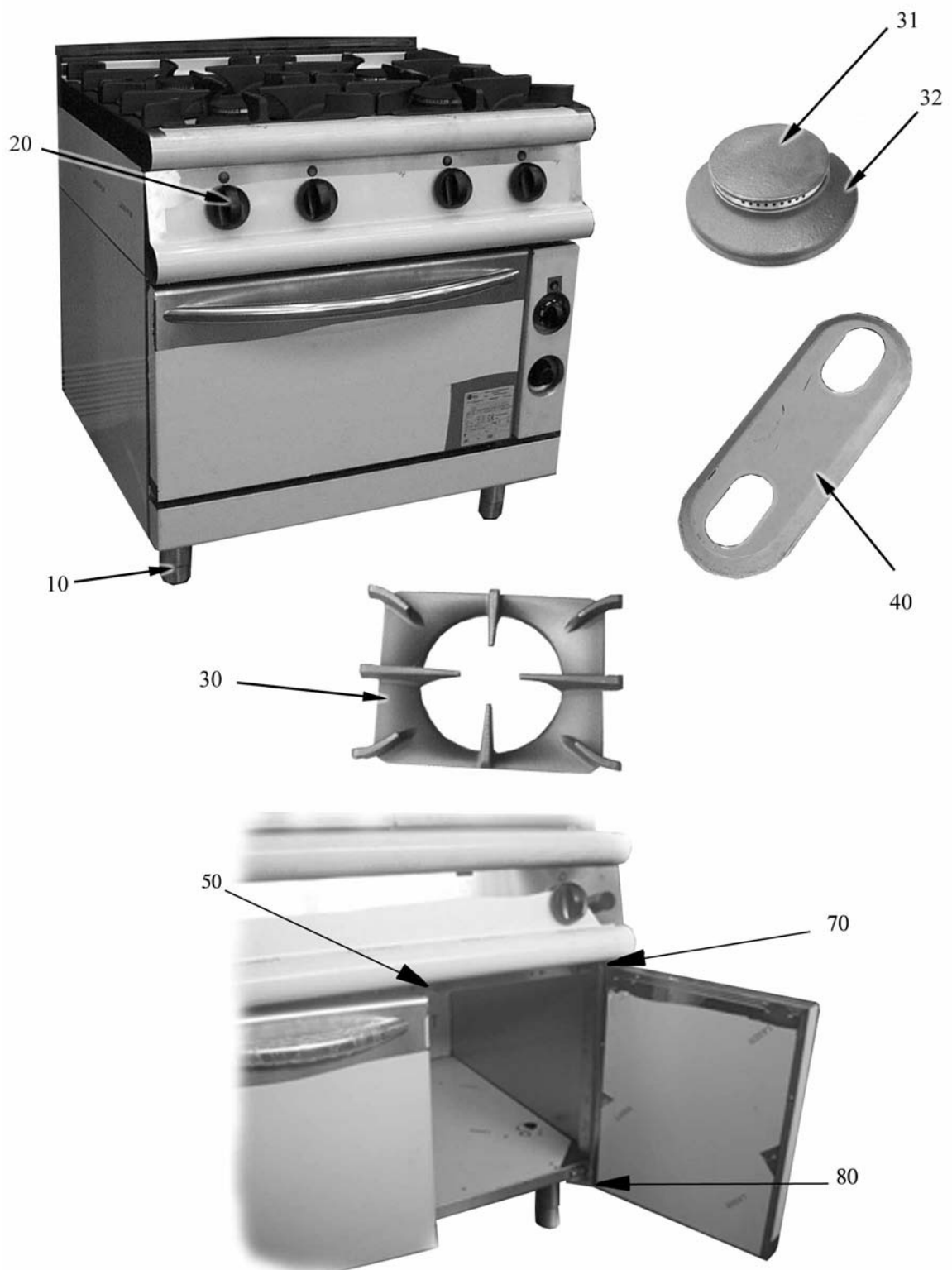



**Parti di ricambio**

ID	Modello	Tipo	Voltaggio	Descrizione	Codici del produttore
<b>Module: Parti esterne fuochi e armadio caldo</b>					
10				Piedino	826490142
20				Manopola cucina gas nera	824710100
30				Griglia smaltata	41822410390
31				Bruciatore (spartifiamma piccolo)	822410071
31				Bruciatore (spartifiamma medio)	822410081
32				Corpo Bruciatore piccolo	822410041
32				Corpo Bruciatore medio	822410051
40				Chisura superiore	41821530120
50		120MF,120MFE		Magnete	826900011
60		120MF,120MFE		Cerniera inferiore dx/superiore sx porta	2547870
70		120MF,120MFE,120F,120FE		Cerniera inferiore sx/superiore dx porta	2547860

800=7TP/G800, 800M=7TPM/G800 SX, 120M=7TPM/G120, 160=7TP/G160, 800V=7TPV/G800, 800MV=7TPMV/G800 SX, 120MV=7TPMV/G120, 160V=7TPV/G160, 800F=7TPF/G800, 800FE=7TPF/GE800, 120F=7TPF/G120, 120FE=7TPF/GE120, 120MF=7TPMF/G120, 120MFE=7TPMF/GE120, 800MF=7TPMF/G800 SX, 800MFE=7TPMF/GE800 SX, 160F=7TP2F/G160, 160FE=7TP2F/GE160

A=3/N/PE~400/230V 50Hz, H=3/PE~230V 50Hz, P=1/N/PE~220-240V 50Hz

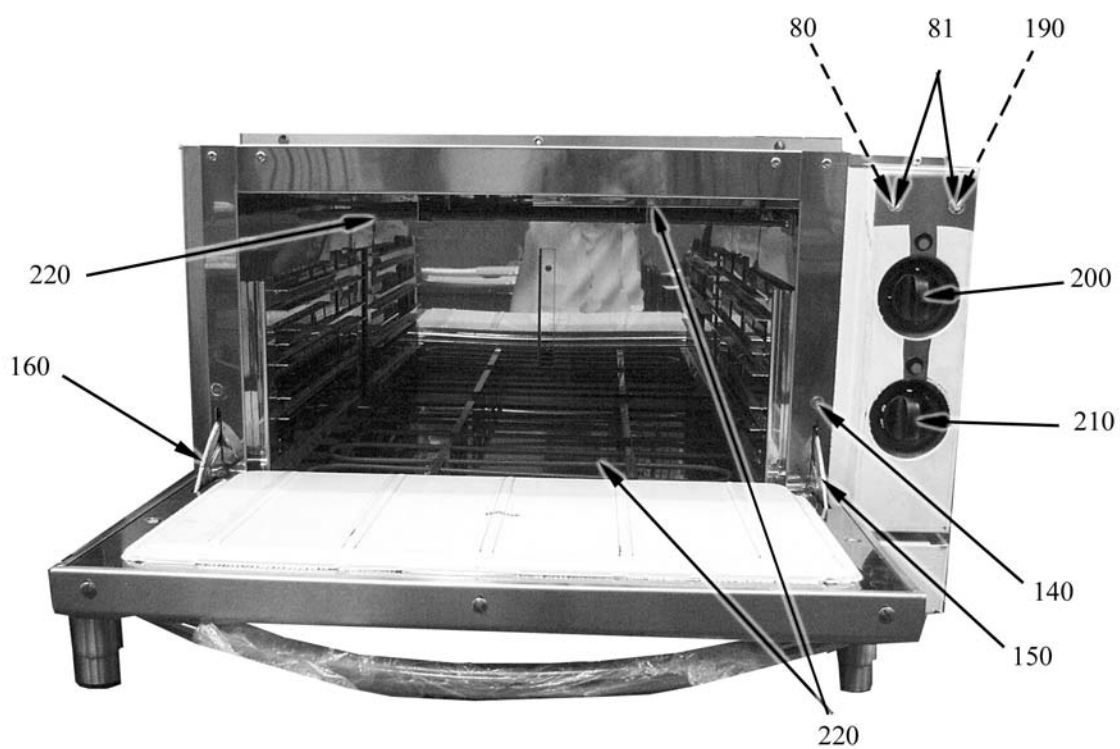

## Parti di ricambio

ID	Modello	Tipo	Voltaggio	Descrizione	Codici del produttore
<b>Module: Parti esterne forno gas ed elettrico</b>					
80		800F,800FE,120F,120FE,120MF,120MFE,800MF,800MFE,160F,160FE		Segnalatore luminoso verde	826650050
81		800F,800FE,120F,120FE,120MF,120MFE,800MF,800MFE,160F,160FE		Gemma bianca	6A039207
100		800F,800FE,120F,120FE,120MF,120MFE,800MF,800MFE,160F,160FE		Manopola nera per forno	824710110
110		800F,800FE,120F,120FE,120MF,120MFE,800MF,800MFE,160F,160FE		Accensione piezoelettrica	41826630020
120		800F,800FE,120F,120FE,120MF,120MFE,800MF,800MFE,160F,160FE		Rondella	822160540
130		800F,800FE,120F,120FE,120MF,120MFE,800MF,800MFE,160F,160FE		Cappuccio	826630420
140		800F,800FE,120F,120FE,120MF,120MFE,800MF,800MFE,160F,160FE		Portarullini per cerniera	6A035930
150		800F,800FE,120F,120FE,120MF,120MFE,800MF,800MFE,160F,160FE		Cerniera dx	6A035910
160		800F,800FE,120F,120FE,120MF,120MFE,800MF,800MFE,160F,160FE		Cerniera sx	6A035920
170		800F,800FE,120F,120FE,120MF,120MFE,800MF,800MFE,160F,160FE		Suola forno	41821410191
180		800F,800FE,120F,120FE,120MF,120MFE,800MF,800MFE,160F,160FE		Griglia	41826330030
190		800F,800FE,120F,120FE,120MF,120MFE,800MF,800MFE,160F,160FE		Segnalatore luminoso arancio	6A038506
200		800F,800FE,120F,120FE,120MF,120MFE,800MF,800MFE,160F,160FE		Manopola commutatore forno elettrico	824710710
210		800F,800FE,120F,120FE,120MF,120MFE,800MF,800MFE,160F,160FE		Manopola forno elettrico nera	824710270
220		800F,800FE,120F,120FE,120MF,120MFE,800MF,800MFE,160F,160FE		Resistenza 1500 W	826620041

800=7TP/G800, 800M=7TPM/G800 SX, 120M=7TPM/G120, 160=7TP/G160, 800V=7TPV/G800, 800MV=7TPMV/G800 SX, 120MV=7TPMV/G120, 160V=7TPV/G160, 800F=7TPF/G800, 800FE=7TPF/GE800, 120F=7TPF/G120, 120FE=7TPF/GE120, 120MF=7TPMF/G120, 120MFE=7TPMF/GE120, 800MF=7TPMF/G800 SX, 800MFE=7TPMF/GE800 SX, 160F=7TP2F/G160, 160FE=7TP2F/GE160

A=3/N/PE~400/230V 50Hz, H=3/PE~230V 50Hz, P=1/N/PE~220-240V 50Hz

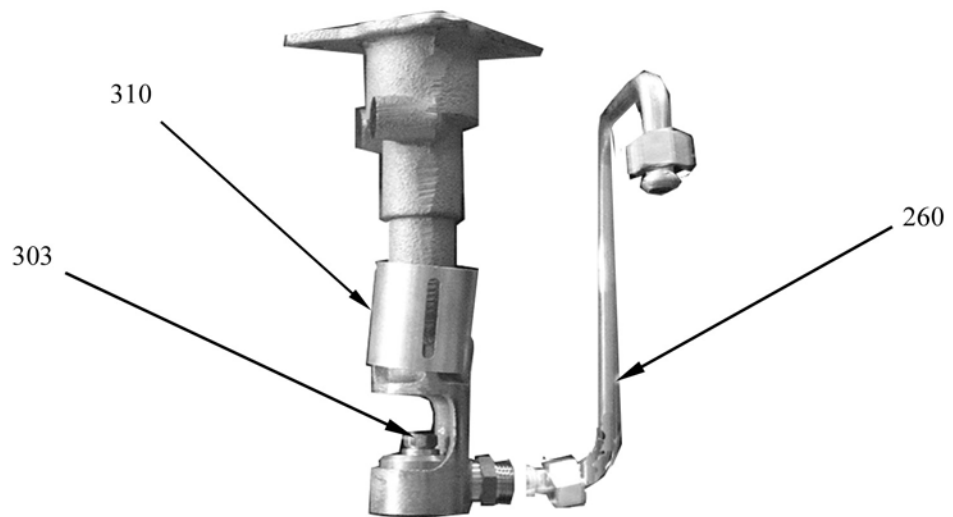
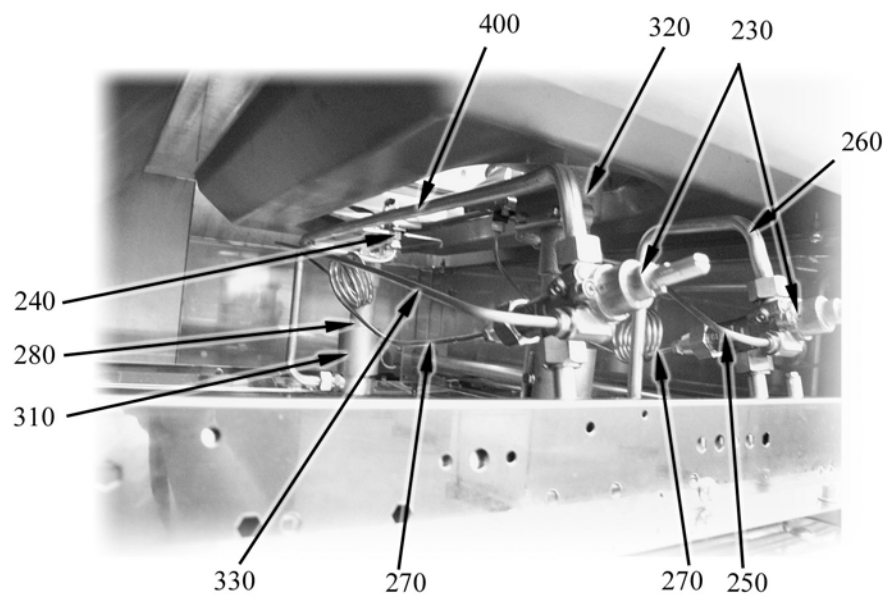

## Parti di ricambio

ID	Tipo	Descrizione	Codici del produttore
<b>Module: Bruciatori e condutture fuochi aperti</b>			
230	120S,120D,800M,120M,160,120SV,120DV,800MV,120MV,160V,120F,120FE,120MF,120MFE,800MF,800MFE,160F,160FE	Rubinetto	6A011490
240	120S,120D,800M,120M,160,120SV,120DV,800MV,120MV,160V,120F,120FE,120MF,120MFE,800MF,800MFE,160F,160FE	Pilota	41826920140
250	120S,120D,800M,120M,160,120SV,120DV,800MV,120MV,160V,120F,120FE,120MF,120MFE,800MF,800MFE,160F,160FE	Conduttura Rub./Pil. ant.	41823561391
260	120S,120D,800M,120M,160,120SV,120DV,800MV,120MV,160V,120F,120FE,120MF,120MFE,800MF,800MFE,160F,160FE	Conduttura Rub./Bruc. ant	41823561370
270	120S,120D,800M,120M,160,120SV,120DV,800MV,120MV,160V,120F,120FE,120MF,120MFE,800MF,800MFE,160F,160FE	Termocoppia	826920080
280	120S,120D,800M,120M,160,120SV,120DV,800MV,120MV,160V,120F,120FE,120MF,120MFE,800MF,800MFE,160F,160FE	Venturi piccolo	822410012
303	120S,120D,800M,120M,160,120SV,120DV,800MV,120MV,160V,120F,120FE,120MF,120MFE,800MF,800MFE,160F,160FE	Ugello L 80	822140270
303	120S,120D,800M,120M,160,120SV,120DV,800MV,120MV,160V,120F,120FE,120MF,120MFE,800MF,800MFE,160F,160FE	Ugello L 105	822140150
303	120S,120D,800M,120M,160,120SV,120DV,800MV,120MV,160V,120F,120FE,120MF,120MFE,800MF,800MFE,160F,160FE	Ugello L 95	822140140
303	120S,120D,800M,120M,160,120SV,120DV,800MV,120MV,160V,120F,120FE,120MF,120MFE,800MF,800MFE,160F,160FE	Ugello L 120	822140160
303	120S,120D,800M,120M,160,120SV,120DV,800MV,120MV,160V,120F,120FE,120MF,120MFE,800MF,800MFE,160F,160FE	Ugello 145	822140040
303	120S,120D,800M,120M,160,120SV,120DV,800MV,120MV,160V,120F,120FE,120MF,120MFE,800MF,800MFE,160F,160FE	Ugello 180	822140210
303	120S,120D,800M,120M,160,120SV,120DV,800MV,120MV,160V,120F,120FE,120MF,120MFE,800MF,800MFE,160F,160FE	Ugello 155	822140190
303	120S,120D,800M,120M,160,120SV,120DV,800MV,120MV,160V,120F,120FE,120MF,120MFE,800MF,800MFE,160F,160FE	Ugello 200	822140220
303	120S,120D,800M,120M,160,120SV,120DV,800MV,120MV,160V,120F,120FE,120MF,120MFE,800MF,800MFE,160F,160FE	Ugello 135	
303	120S,120D,800M,120M,160,120SV,120DV,800MV,120MV,160V,120F,120FE,120MF,120MFE,800MF,800MFE,160F,160FE	Ugello 115	

**Parti di ricambio**

ID	Tipo	Descrizione	Codici del produttore
303	120S,120D,800M,120M,160,120SV,120DV,800MV,120MV,160V,120F,120FE,120MF,120MFE,800MF,800MFE,160F,160FE	Ugello 225	
310	120S,120D,800M,120M,160,120SV,120DV,800MV,120MV,160V,120F,120FE,120MF,120MFE,800MF,800MFE,160F,160FE	Regolatore d'aria	822120020
320	120S,120D,800M,120M,160,120SV,120DV,800MV,120MV,160V,120F,120FE,120MF,120MFE,800MF,800MFE,160F,160FE	Venturi medio	822410022
321	120S,120D,800M,120M,160,120SV,120DV,800MV,120MV,160V,120F,120FE,120MF,120MFE,800MF,800MFE,160F,160FE	Venturi piccolo	822410012
322	120S,120D,800M,120M,160,120SV,120DV,800MV,120MV,160V,120F,120FE,120MF,120MFE,800MF,800MFE,160F,160FE	Venturi grande	822410032
330	120S,120D,800M,120M,160,120SV,120DV,800MV,120MV,160V,120F,120FE,120MF,120MFE,800MF,800MFE,160F,160FE	Conduttura Rub./Pil. post.	41823561381
400	120S,120D,800M,120M,160,120SV,120DV,800MV,120MV,160V,120F,120FE,120MF,120MFE,800MF,800MFE,160F,160FE	Conduttura Rub./Bruc. Post.	41823561360

800=7TP/G800, 800M=7TPM/G800 SX, 120M=7TPM/G120, 160=7TP/G160, 800V=7TPV/G800, 800MV=7TPMV/G800 SX, 120MV=7TPMV/G120, 160V=7TPV/G160, 800F=7TPF/G800, 800FE=7TPF/GE800, 120F=7TPF/G120, 120FE=7TPF/GE120, 120MF=7TPMF/G120, 120MFE=7TPMF/GE120, 800MF=7TPMF/G800 SX, 800MFE=7TPMF/GE800 SX, 160F=7TP2F/G160, 160FE=7TP2F/GE160

A=3/N/PE~400/230V 50Hz, H=3/PE~230V 50Hz, P=1/N/PE~220-240V 50Hz



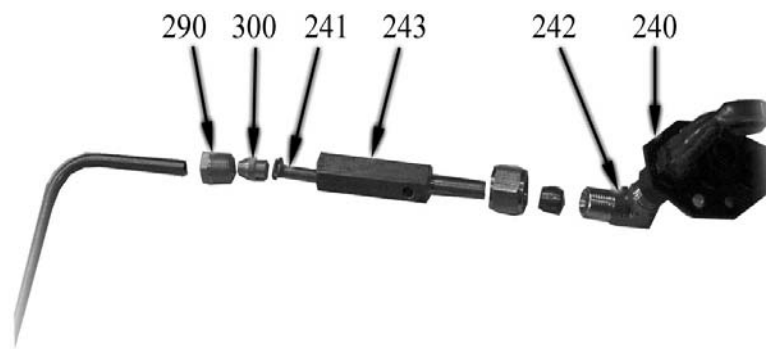



## Parti di ricambio

ID	Modello	Tipo	Voltaggio	Descrizione	Codici del produttore
<b>Module: Bruciatori e condutture fuochi aperti</b>					
240		120S,120D,800M,120M,160,120SV,120DV,800MV,120MV,160V,120F,120FE,120MF,120MFE,800MF,800MFE,160F,160FE		Pilota	41826920140
241		120S,120D,800M,120M,160,120SV,120DV,800MV,120MV,160V,120F,120FE,120MF,120MFE,800MF,800MFE,160F,160FE		Ugello 19	822140380
241		120S,120D,800M,120M,160,120SV,120DV,800MV,120MV,160V,120F,120FE,120MF,120MFE,800MF,800MFE,160F,160FE		Ugello 27	6A013107
242		120S,120D,800M,120M,160,120SV,120DV,800MV,120MV,160V,120F,120FE,120MF,120MFE,800MF,800MFE,160F,160FE		Raccordo 90	822450610
243		120S,120D,800M,120M,160,120SV,120DV,800MV,120MV,160V,120F,120FE,120MF,120MFE,800MF,800MFE,160F,160FE		Prolunga pilota fuochi	822160460
290		120S,120D,800M,120M,160,120SV,120DV,800MV,120MV,160V,120F,120FE,120MF,120MFE,800MF,800MFE,160F,160FE		Raccordo bicono	822450040
300		120S,120D,800M,120M,160,120SV,120DV,800MV,120MV,160V,120F,120FE,120MF,120MFE,800MF,800MFE,160F,160FE		Bicono	822450050

800=7TP/G800, 800M=7TPM/G800 SX, 120M=7TPM/G120, 160=7TP/G160, 800V=7TPV/G800, 800MV=7TPMV/G800 SX, 120MV=7TPMV/G120, 160V=7TPV/G160, 800F=7TPF/G800, 800FE=7TPF/GE800, 120F=7TPF/G120, 120FE=7TPF/GE120, 120MF=7TPMF/G120, 120MFE=7TPMF/GE120, 800MF=7TPMF/G800 SX, 800MFE=7TPMF/GE800 SX, 160F=7TP2F/G160, 160FE=7TP2F/GE160

A=3/N/PE~400/230V 50Hz, H=3/PE~230V 50Hz, P=1/N/PE~220-240V 50Hz

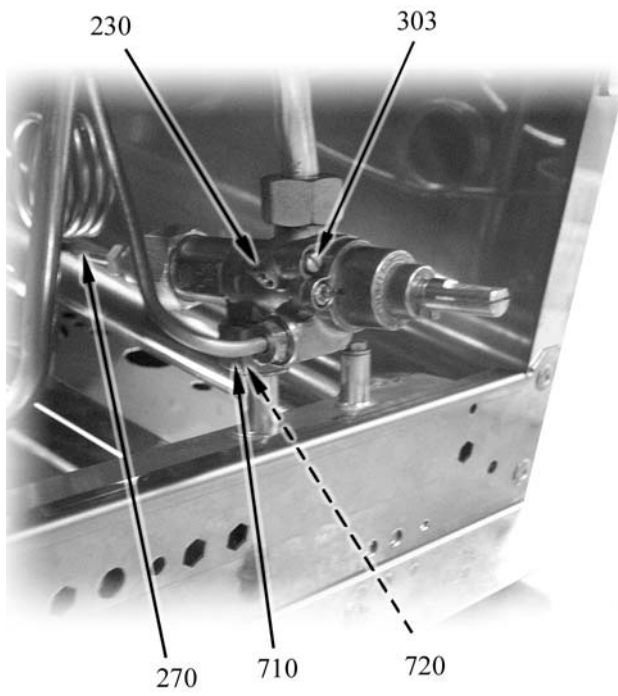

## Parti di ricambio

ID	Modello	Tipo	Voltaggio	Descrizione	Codici del produttore
<b>Module:Rubinetto</b>					
230		120S,120D,800M,120M,160,120SV,120DV,800MV,120MV,160V,120F,120FE,120MF,120MFE,800MF,800MFE,160F,160FE		Rubinetto	6A011490
270		120S,120D,800M,120M,160,120SV,120DV,800MV,120MV,160V,120F,120FE,120MF,120MFE,800MF,800MFE,160F,160FE		Termocoppia	826920080
303		120S,120D,800M,120M,160,120SV,120DV,800MV,120MV,160V,120F,120FE,120MF,120MFE,800MF,800MFE,160F,160FE		Vite di minimo 80	822450240
303		120S,120D,800M,120M,160,120SV,120DV,800MV,120MV,160V,120F,120FE,120MF,120MFE,800MF,800MFE,160F,160FE		Vite di minimo 120	822450280
303		120S,120D,800M,120M,160,120SV,120DV,800MV,120MV,160V,120F,120FE,120MF,120MFE,800MF,800MFE,160F,160FE		Vite di minimo 50	822450210
303		120S,120D,800M,120M,160,120SV,120DV,800MV,120MV,160V,120F,120FE,120MF,120MFE,800MF,800MFE,160F,160FE		Vite di minimo 75	822450230
303		120S,120D,800M,120M,160,120SV,120DV,800MV,120MV,160V,120F,120FE,120MF,120MFE,800MF,800MFE,160F,160FE		Vite di minimo 90	822450260
303		120S,120D,800M,120M,160,120SV,120DV,800MV,120MV,160V,120F,120FE,120MF,120MFE,800MF,800MFE,160F,160FE		Vite di minimo 130	822450290
303		120S,120D,800M,120M,160,120SV,120DV,800MV,120MV,160V,120F,120FE,120MF,120MFE,800MF,800MFE,160F,160FE		Vite di minimo 45	6A023722
303		120S,120D,800M,120M,160,120SV,120DV,800MV,120MV,160V,120F,120FE,120MF,120MFE,800MF,800MFE,160F,160FE		Vite di minimo 65	6A023723
710		120S,120D,800M,120M,160,120SV,120DV,800MV,120MV,160V,120F,120FE,120MF,120MFE,800MF,800MFE,160F,160FE		Dado	6A011485
720		120S,120D,800M,120M,160,120SV,120DV,800MV,120MV,160V,120F,120FE,120MF,120MFE,800MF,800MFE,160F,160FE		Bicono	6A011480

800=7TP/G800, 800M=7TPM/G800 SX, 120M=7TPM/G120, 160=7TP/G160, 800V=7TPV/G800, 800MV=7TPMV/G800 SX, 120MV=7TPMV/G120, 160V=7TPV/G160, 800F=7TPF/G800, 800FE=7TPF/GE800, 120F=7TPF/G120, 120FE=7TPF/GE120, 120MF=7TPMF/G120, 120MFE=7TPMF/GE120, 800MF=7TPMF/G800 SX, 800MFE=7TPMF/GE800 SX, 160F=7TP2F/G160, 160FE=7TP2F/GE160

A=3/N/PE~400/230V 50Hz, H=3/PE~230V 50Hz, P=1/N/PE~220-240V 50Hz

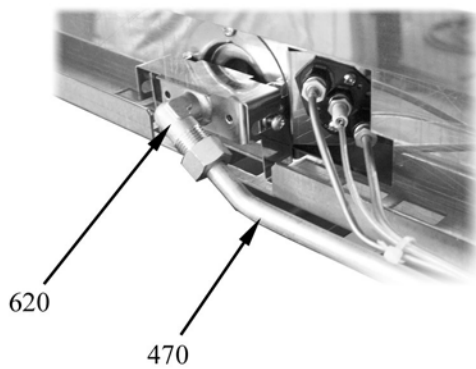
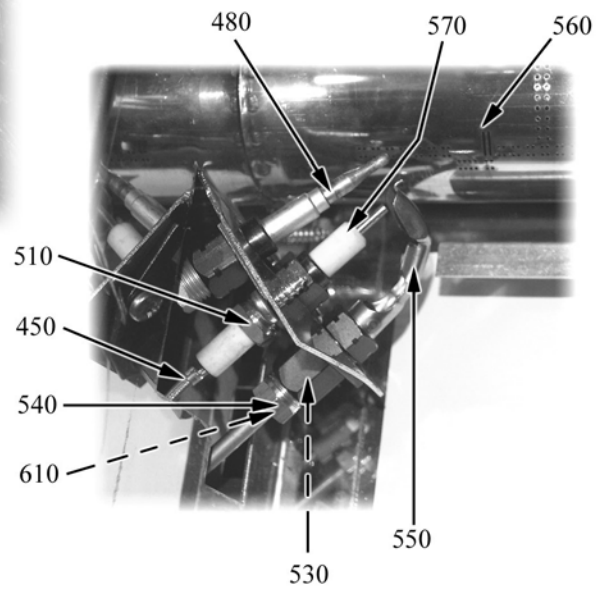
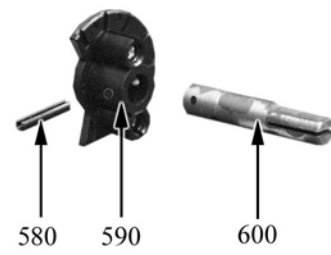
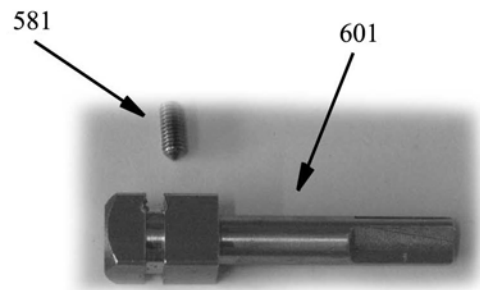
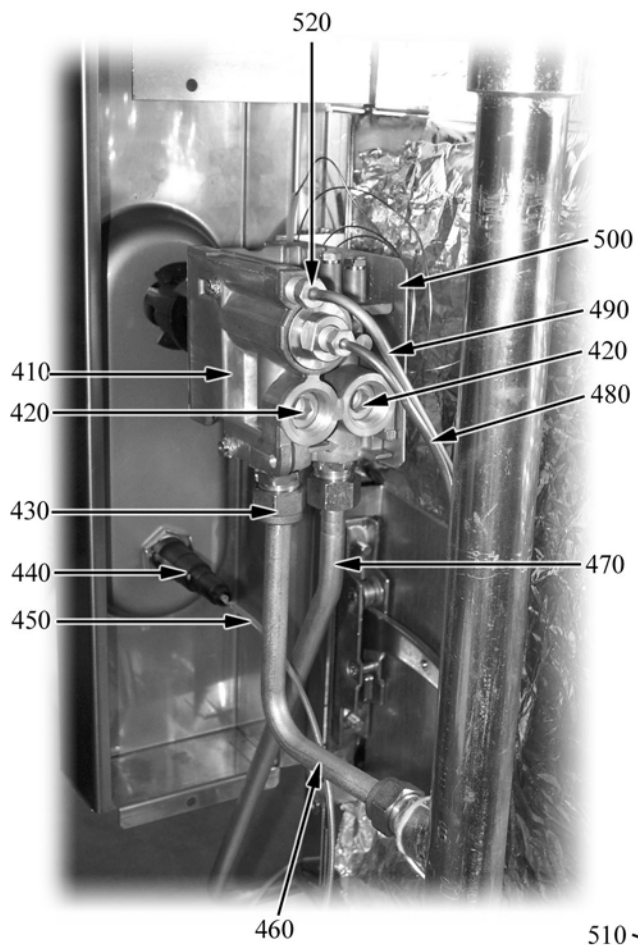

## Parti di ricambio

ID	Modello	Tipo	Voltaggio	Descrizione	Codici del produttore
<b>Module: Componenti forno a gas (valvola, regolazione aria, bruciatore)</b>					
410		800F,120F,120MF,800MF,160F		Valvola	826920012
420		800F,120F,120MF,800MF,160F		Tappo	8219951
430		800F,120F,120MF,800MF,160F		Raccordo	822450170
440		800F,120F,120MF,800MF,160F		Accensione piezoelettrica	41826630020
450		800F,120F,120MF,800MF,160F		Cavo d'accensione	2510698
460		800F,120F,120MF,800MF,160F		Conduttura Valvola/Rampa	2514615
470		800F,120F,120MF,800MF,160F		Conduttura Valvola/Bruciatore forno	823560060
480		800F,120F,120MF,800MF,160F		Termocoppia	826920080
490		800F,120F,120MF,800MF,160F		Conduttura Valvola/Pilota forno	823560070
500		800F,120F,120MF,800MF,160F		Squadretta	41821120040
510		800F,120F,120MF,800MF,160F		Raccordo	6A011707
520		800F,120F,120MF,800MF,160F		Raccordo bicono	6A011608
530		800F,120F,120MF,800MF,160F		Ugello 19	822140380
530		800F,120F,120MF,800MF,160F		Ugello 27	6A013107
540		800F,120F,120MF,800MF,160F		Raccordo	822450040
550		800F,120F,120MF,800MF,160F		Pilota	826920070
560		800F,120F,120MF,800MF,160F		Bruciatore	2510697
570		800F,120F,120MF,800MF,160F		Candela	6A013301
580		800F,120F,120MF,800MF,160F		Spina elastica	418227993140
581		800F,120F,120MF,800MF,160F		Grano di fissaggio	6A009190
590		800F,120F,120MF,800MF,160F		Flangia	2518660
600		800F,120F,120MF,800MF,160F		Attacco manopola	2518650
581		800F,120F,120MF,800MF,160F		Attacco manopola	2518660
610		800F,120F,120MF,800MF,160F		Bicono	822450050
620		800F,120F,120MF,800MF,160F		Raccordo	822450010

800=7TP/G800, 800M=7TPM/G800 SX, 120M=7TPM/G120, 160=7TP/G160, 800V=7TPV/G800, 800MV=7TPMV/G800 SX, 120MV=7TPMV/G120, 160V=7TPV/G160, 800F=7TPF/G800, 800FE=7TPF/GE800, 120F=7TPF/G120, 120FE=7TPF/GE120, 120MF=7TPMF/G120, 120MFE=7TPMF/GE120, 800MF=7TPMF/G800 SX, 800MFE=7TPMF/GE800 SX, 160F=7TP2F/G160, 160FE=7TP2F/GE160

A=3/N/PE~400/230V 50Hz, H=3/PE~230V 50Hz, P=1/N/PE~220-240V 50Hz

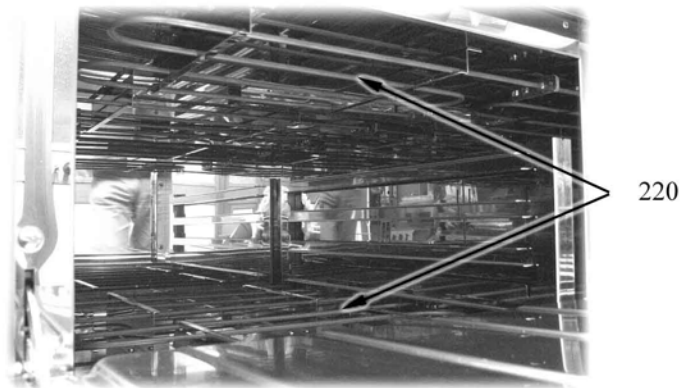
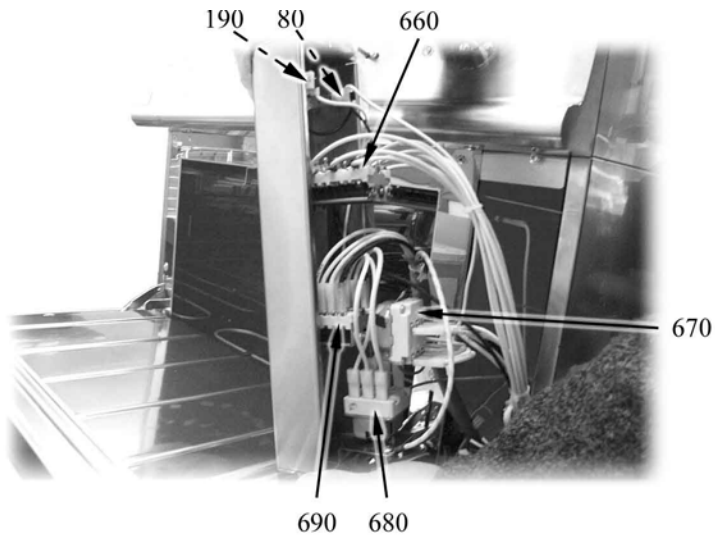

## Parti di ricambio

ID	Modello	Tipo	Voltaggio	Descrizione	Codici del produttore
<b>Module: Componenti forno elettrico e armadio caldo</b>					
80		800FE,120FE,120MFE,800MFE,160FE		Segnalatore luminoso verde	826650050
81		800FE,120FE,120MFE,800MFE,160FE		Gemma bianca	6A039207
190		800FE,120FE,120MFE,800MFE,160FE		Segnalatore luminoso arancio	6A038506
220		800FE,120FE,120MFE,800MFE,160FE		Resistenza 1500 W	826620041
660		800FE,120FE,120MFE,800MFE,160FE		Commutatore	6A046750
670		800FE,120FE,120MFE,800MFE,160FE		Termostato	826630123
680		800FE,120FE,120MFE,800MFE,160FE		Termostato sicurezza	826630130
690		800FE,120FE,120MFE,800MFE,160FE		Commutatore	6A046001

800=7TP/G800, 800M=7TPM/G800 SX, 120M=7TPM/G120, 160=7TP/G160, 800V=7TPV/G800, 800MV=7TPMV/G800 SX, 120MV=7TPMV/G120, 160V=7TPV/G160, 800F=7TPF/G800, 800FE=7TPF/GE800, 120F=7TPF/G120, 120FE=7TPF/GE120, 120MF=7TPMF/G120, 120MFE=7TPMF/GE120, 800MF=7TPMF/G800 SX, 800MFE=7TPMF/GE800 SX, 160F=7TP2F/G160, 160FE=7TP2F/GE160

A=3/N/PE~400/230V 50Hz, H=3/PE~230V 50Hz, P=1/N/PE~220-240V 50Hz

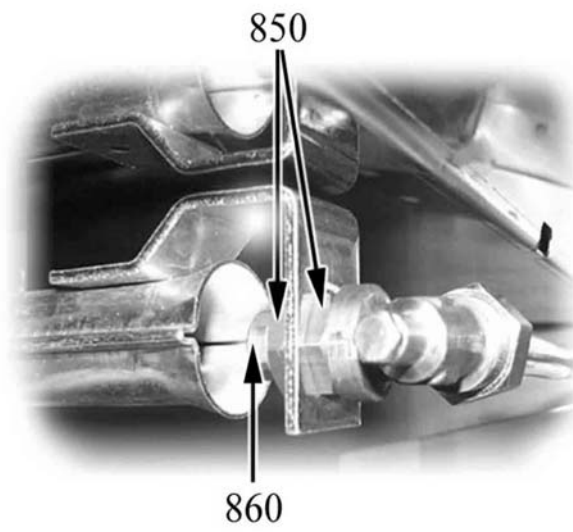
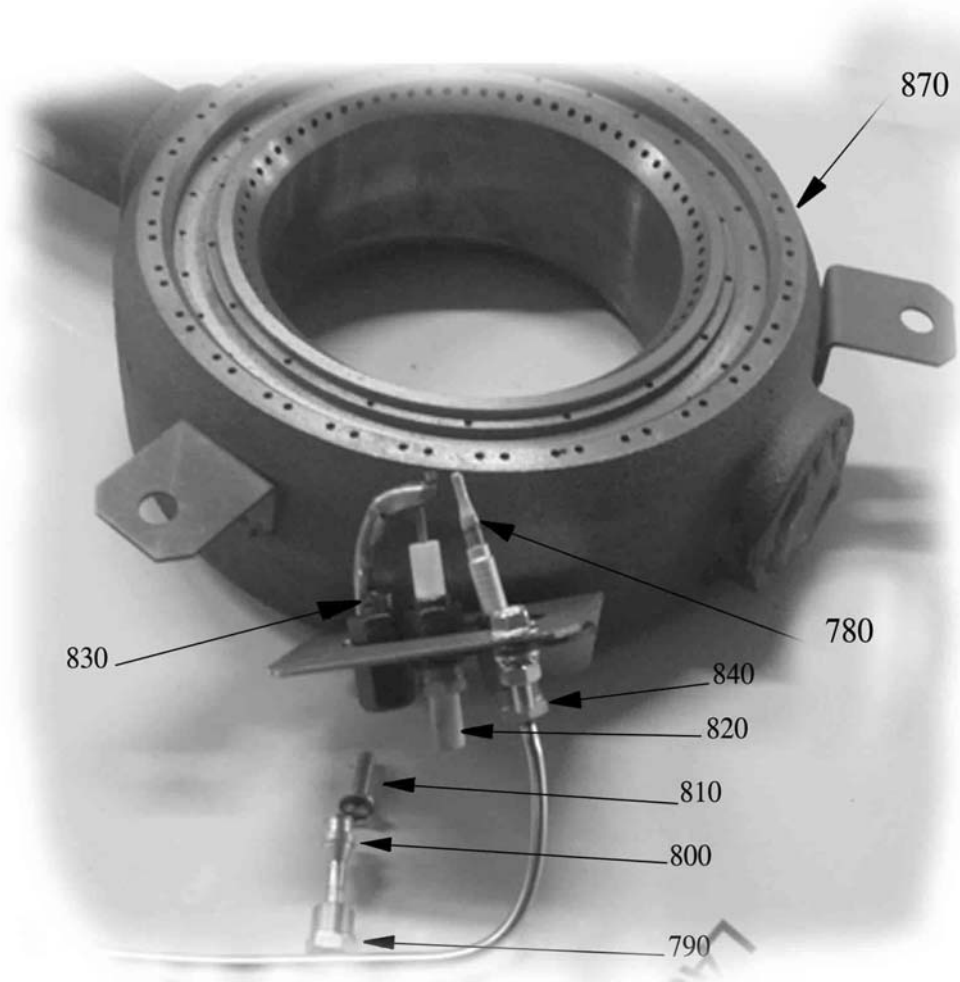



## Parti di ricambio

ID	Modello	Tipo	Voltaggio	Descrizione	Codici del produttore
<b>Module: Componenti forno elettrico e armadio caldo</b>					
780		800,120S,120D,160,800V,120SV,120DV,160V,800F,800FE,120F,120FE,160F,160FE		Termocoppia	
790		800,120S,120D,160,800V,120SV,120DV,160V,800F,800FE,120F,120FE,160F,160FE		Dado	
800		800,120S,120D,160,800V,120SV,120DV,160V,800F,800FE,120F,120FE,160F,160FE		Bicono	
810		800,120S,120D,160,800V,120SV,120DV,160V,800F,800FE,120F,120FE,160F,160FE		Ugello	
820		800,120S,120D,160,800V,120SV,120DV,160V,800F,800FE,120F,120FE,160F,160FE		Candela di accensione	
830		800,120S,120D,160,800V,120SV,120DV,160V,800F,800FE,120F,120FE,160F,160FE		Pilota	
870		800,120S,120D,160,800V,120SV,120DV,160V,800F,800FE,120F,120FE,160F,160FE		Bruciatore tuttapietra	
840		800,120S,120D,160,800V,120SV,120DV,160V,800F,800FE,120F,120FE,160F,160FE		Controdado	
850		800,120S,120D,160,800V,120SV,120DV,160V,800F,800FE,120F,120FE,160F,160FE		Conrtodado	
860		800,120S,120D,160,800V,120SV,120DV,160V,800F,800FE,120F,120FE,160F,160FE		Ugello D 2.50	
860		800,120S,120D,160,800V,120SV,120DV,160V,800F,800FE,120F,120FE,160F,160FE		Ugello D 1.65	
860		800,120S,120D,160,800V,120SV,120DV,160V,800F,800FE,120F,120FE,160F,160FE		Ugello D 2.70	
860		800,120S,120D,160,800V,120SV,120DV,160V,800F,800FE,120F,120FE,160F,160FE		Ugello D145 GPL	

800=7TP/G800, 800M=7TPM/G800 SX, 120M=7TPM/G120, 160=7TP/G160, 800V=7TPV/G800, 800MV=7TPMV/G800 SX, 120MV=7TPMV/G120, 160V=7TPV/G160, 800F=7TPF/G800, 800FE=7TPF/GE800, 120F=7TPF/G120, 120FE=7TPF/GE120, 120MF=7TPMF/G120, 120MFE=7TPMF/GE120, 800MF=7TPMF/G800 SX, 800MFE=7TPMF/GE800 SX, 160F=7TP2F/G160, 160FE=7TP2F/GE160

A=3/N/PE~400/230V 50Hz, H=3/PE~230V 50Hz, P=1/N/PE~220-240V 50Hz

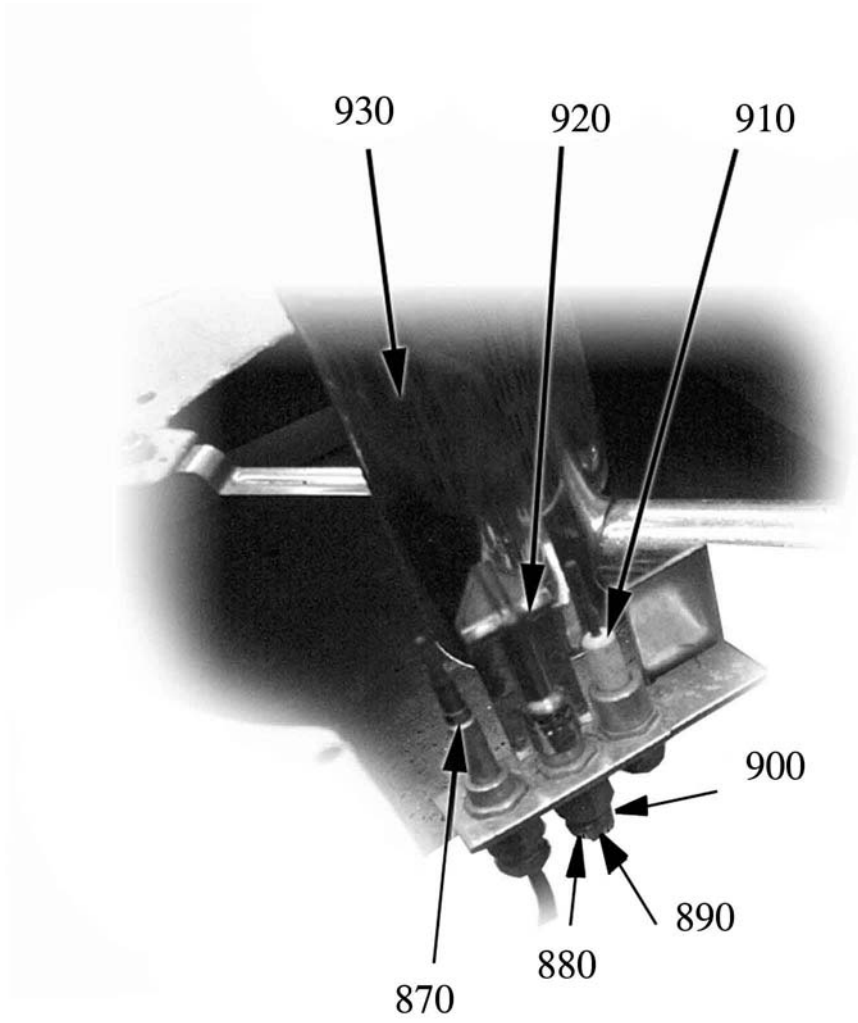

## Parti di ricambio

ID	Modello	Tipo	Voltaggio	Descrizione	Codici del produttore
<b>Module: Componenti forno elettrico e armadio caldo</b>					
870		800M,120M,800MV,120MV,120MF,120MFE,800MF,800MFE		Termocoppia	
880		800M,120M,800MV,120MV,120MF,120MFE,800MF,800MFE		Dado	
890		800M,120M,800MV,120MV,120MF,120MFE,800MF,800MFE		Bicono	
900		800M,120M,800MV,120MV,120MF,120MFE,800MF,800MFE		Ugello 27.2	
900		800M,120M,800MV,120MV,120MF,120MFE,800MF,800MFE		Ugello	
910		800M,120M,800MV,120MV,120MF,120MFE,800MF,800MFE		Candela di accensione	
920		800M,120M,800MV,120MV,120MF,120MFE,800MF,800MFE		Pilota	
930		800M,120M,800MV,120MV,120MF,120MFE,800MF,800MFE		Bruciatore tuttapietra	

800=7TP/G800, 800M=7TPM/G800 SX, 120M=7TPM/G120, 160=7TP/G160, 800V=7TPV/G800, 800MV=7TPMV/G800 SX, 120MV=7TPMV/G120, 160V=7TPV/G160, 800F=7TPF/G800, 800FE=7TPF/GE800, 120F=7TPF/G120, 120FE=7TPF/GE120, 120MF=7TPMF/G120, 120MFE=7TPMF/GE120, 800MF=7TPMF/G800 SX, 800MFE=7TPMF/GE800 SX, 160F=7TP2F/G160, 160FE=7TP2F/GE160

A=3/N/PE~400/230V 50Hz, H=3/PE~230V 50Hz, P=1/N/PE~220-240V 50Hz



**Parti di ricambio**

ID	Modello	Tipo	Voltaggio	Descrizione	Codici del produttore
<b>Module: Componenti forno elettrico e armadio caldo</b>					
940		800M,120M,800MV,120MV,120MF,120MFE,800MF,800MFE		Controdado	
950		800M,120M,800MV,120MV,120MF,120MFE,800MF,800MFE		Ugello 120	
950		800M,120M,800MV,120MV,120MF,120MFE,800MF,800MFE		Ugello 180	

800=7TP/G800, 800M=7TPM/G800 SX, 120M=7TPM/G120, 160=7TP/G160, 800V=7TPV/G800, 800MV=7TPMV/G800 SX, 120MV=7TPMV/G120, 160V=7TPV/G160, 800F=7TPF/G800, 800FE=7TPF/GE800, 120F=7TPF/G120, 120FE=7TPF/GE120, 120MF=7TPMF/G120, 120MFE=7TPMF/GE120, 800MF=7TPMF/G800 SX, 800MFE=7TPMF/GE800 SX, 160F=7TP2F/G160, 160FE=7TP2F/GE160

A=3/N/PE~400/230V 50Hz, H=3/PE~230V 50Hz, P=1/N/PE~220-240V 50Hz

