

FRY-TOP ELETTRICI Serie 700

TIPO: 7FT/E400, 7FT/E405, 7FT/E410, 7FT/E415, 7FT/E800, 7FT/E805, 7FT/E810, 7FT/E815, 7FT/E820, 7FT/E825, 7FTV/E400, 7FTV/E405, 7FTV/E410, 7FTV/E415, 7FTV/E800, 7FTV/E805, 7FTV/E810, 7FTV/E815, 7FTV/E820, 7TV/E825

Ricambi



8. Parti di ricambio

Parti esterne..... 23

Componenti interni..... 25

8.1 Codici di voltaggio

Voltaggio	Codice di voltaggio
A	3/N/PE~400/230V 50Hz
B	~250V 16A 50Hz
C	3/N/PE~380/220V 50Hz
D	3/PE~200V 50-60Hz
F	2/PE 220-240V 50Hz
G	3/N/PE~415/240V 50Hz
H	3/PE~230V 50Hz
I	3/PE~220V 60Hz
J	3/PE~380 50Hz
K	3/PE~400V 50Hz
L	3/PE~415V 50Hz
M	3/PE~440V 60Hz
N	3/PE~460V 60Hz
O	3/PE~480V 60Hz
P	1/N/PE~220-240V 50Hz
R	2/PE~220-230V 60Hz
S	3/N/PE~400/230V 50Hz
T	3/PE~230V 60Hz
U	1/N/PE~100V 50-60Hz

8.2 Codici dei prodotti

Codici del prodotto	Nome completo
Codici dei tipi	
400	7FT/E400
405	7FT/E405
410	7FT/E410
415	7FT/E415
800	7FT/E800
805	7FT/E805
810	7FT/E810
815	7FT/E815
820	7FT/E820
825	7FT/E825
400V	7FTV/E400
405V	7FTV/E405
410V	7FTV/E410
415V	7FTV/E415
800V	7FTV/E800
805V	7FTV/E805
810V	7FTV/E810
815V	7FTV/E815
820V	7FTV/E820
825V	7FTV/E400



Parti di ricambio

ID	Tipo	Descrizione	Codici del produttore
Module: Parti esterne			
10		Piedino	826490142
20		Cassetto	41826161370
35	400E,400VE	Piastra	41826470590
	410E,410VE	Piastra	41826470650
	405E,405VE	Piastra	41826470690
	415E,415VE	Piastra	41826470750
	800E,800VE	Piastra	41826470700
	820E,820VE	Piastra	41826470630
	810E,810VE	Piastra	41826470660
	805E,805VE	Piastra	41826470700
	825E,825VE	Piastra	41826470730
	815E,815VE	Piastra	41826470760
40		Manopola	824710250
41		Guarnizione manopola	825110510
50		Gemma verde	826650050
55		Segnalatori luminosi	6A038506
60		Gemma bianca	6A039207

400E=7FT/E400, 405E=7FT/E405, 410E=7FT/E410, 415E=7FT/E415, 800E=7FT/E800, 805E=7FT/E805, 810E=7FT/E810, 815E=7FT/E815, 820E=7FT/E820, 825E=7FT/E825, 400VE=7FTV/E400, 405VE=7FTV/E405, 410VE=7FTV/E410, 415VE=7FTV/E415, 800VE=7FTV/E800, 805VE=7FTV/E05, 810VE=7FTV/E810, 815VE=7FTV/E815, 820VE=7FTV/E820, 825VE=7TV/E825

A=3/N/PE~400/230V 50Hz, H=3/PE~230V 50Hz, P=1/N/PE~220-240V 50Hz

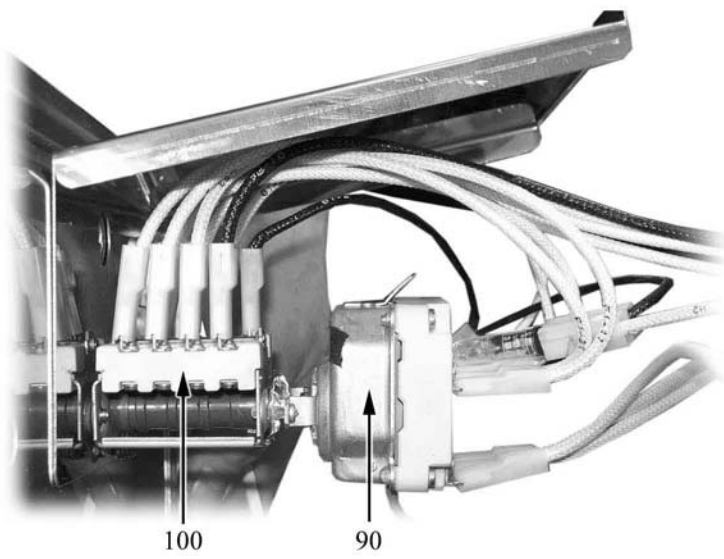
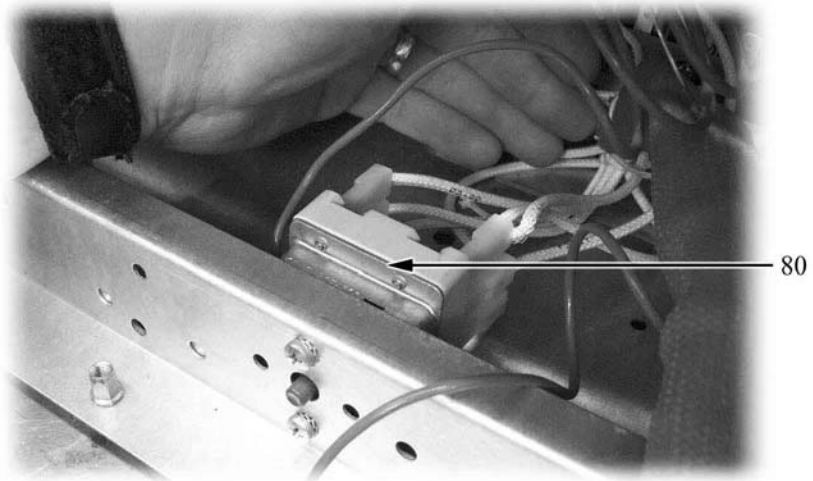
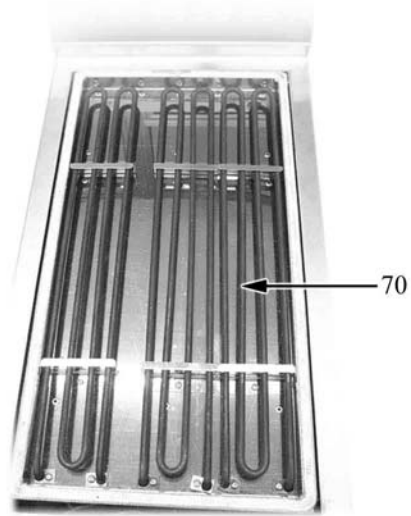

Parti di ricambio

ID	Tipo	Descrizione	Codici del produttore
Module:Componenti interni			
70		Resistenza 1266 W	41826620070
80		Termostato sicurezza	826630130
90		Termostato	826630123
100		Commutatore	6A046001

400E=7FT/E400, 405E=7FT/E405, 410E=7FT/E410, 415E=7FT/E415, 800E=7FT/E800, 805E=7FT/E805, 810E=7FT/E810, 815E=7FT/E815, 820E=7FT/E820, 825E=7FT/E825, 400VE=7FTV/E400, 405VE=7FTV/E405, 410VE=7FTV/E410, 415VE=7FTV/E415, 800VE=7FTV/E800, 805VE=7FTV/E05, 810VE=7FTV/E810, 815VE=7FTV/E815, 820VE=7FTV/E820, 825VE=7TV/E825

A=3/N/PE~400/230V 50Hz, H=3/PE~230V 50Hz, P=1/N/PE~220-240V 50Hz

